



SERVICE DATA

CHAIN SAW

ECHO: CS-4010EC

(Serial number : F00140000001 - F00140999999)

shindaiwa: 410EC

(Serial number : F00240000001 - F00240999999)

INTRODUCTION

We are constantly working on technical improvement of our products. For this reason, technical data, equipment and design are subject to change without notice. All specifications and directions in this SERVICE DATA are based on the latest product information available at the time of publication.

CONTENTS

1 SERVICE INFORMATION.....	2
1-1 Specifications.....	2
1-2 Technical data.....	3
1-3 Torque limits and Special maintenance materials....	4
1-4 Service Limits	8
1-5 Special tools	9

Reference No. **01-41C-01**

REVISED : 202401



1 SERVICE INFORMATION

1-1 Specifications

Dimensions	Length*	mm(in)	396 (15.6)
	Width	mm(in)	237 (9.3)
	Height	mm(in)	274 (10.8)
Dry weight*		kg(lb)	4.2 (9.3)
Engine	Type		YAMABIKO, stratified scavenging, air-cooled, two-stroke, single cylinder
	Rotation		Clockwise as viewed from the output end
	Displacement	cm ³ (in ³)	41.6 (2.538)
	Bore	mm(in)	42.0 (1.654)
	Stroke	mm(in)	30.0 (1.181)
	Compression ratio		7.8
Carburetor	Type		Diaphragm, horizontal-draft
	Model		HLI GC-06
	Venturi size-Throttle bore	mm(in)	16 - 17.5 (0.630 - 0.689)
	Choke		Electronic control system
Ignition	Type		CDI (Capacitor discharge ignition) system, Digital Magneto
	Spark plug		NGK BPMR8Y
Exhaust	Muffler type		Spark arrester muffler
Starter	Type		ES (Effortless-Start) / S (Soft-start)
	Rope diameter x length	mm(in)	3.5 x 900 (0.14 x 35.4)
Fuel	Type		Mixed two-stroke fuel
	Mixture ratio		50 : 1 (2 %)
	Gasoline		Minimum 89 octane
	Two-stroke air cooled engine oil		ISO-L-EGD (ISO/CD13738), JASO FC/FD
	Tank capacity	L (UK.fl.oz.)	0.35 (11.8)
Clutch	Type		Centrifugal type, 3-shoes slide with 3-tension springs
Guide bar / Saw chain lubrication type			Adjustable automatic oiler
Oil	Tank capacity	L (UK.fl.oz.)	0.23 (7.8)
Auto oiler	Type		Clutch driven type
Sprocket	Type		Spur
	Number of teeth		7
	Pitch	in	0.325

* Without guide bar and saw chain.

Cutting devices						
Guide bar	Type		B38S95-64ML	Y38S20-64ML	B45S95-72ML	Y45S20-72ML
	Called length	cm	38		45	
	Gauge	in	0.050			
Saw chain	Type		Oregon 95TXL			
	Number of drive links		64		72	
	Pitch	in	0.325			
	Gauge	in	0.050			

1-2 Technical data

Engine				
Compression pressure	MPa (kgf/cm ²) (psi)		1.07 (10.9) (155)	
Clutch engagement speed	r/min		4200	
Ignition system				
Spark plug gap	mm(in)		0.6 - 0.7 (0.024 - 0.028)	
Spark test	Tester gap w/ spark plug	mm(in)	4.0 (0.16)	
	Tester gap w/o spark plug	mm(in)	6.0 (0.24)	
Secondary coil resistance	kΩ		2.5 - 2.9	
Pole shoe air gaps	mm(in)		0.3 - 0.4 (0.012 - 0.016)	
Ignition timing	at 3000 r/min	°BTDC	11	
	at 10000 r/min	°BTDC	30	
Carburetor				
Test Pressure, minimum	MPa (kgf/cm ²) (psi)		0.05 (0.5) (7.0)	
Metering lever height	mm(in)		0.1 - 0.25 (0.004 - 0.010) lower than diaphragm seat	
Tool to adjust mixture needles			D-shaped tool (L) P/N X645-000032 (Carb. adjustment tool P/N Y089-000095)	
Carburetor adjustment				
Fuel type:			Mixed two-stroke Regular fuel	Mixed two-stroke E10 fuel
				Premixed Alkylate fuel
1) Initial setting	H mixture needle	turn out	2 1/2	
	L mixture needle	turn out	2 3/4	
	Throttle adjust screw	turn out*1	4 3/8	
Engine warm-up	Idle - WOT : Total	sec.	5 - 10 : 150	
2) Verify engine speed and smooth acceleration	r/min		Idle: 2700 - 3500 WOT: 11400 - 12200 WOT: 11900 - 12700 WOT: 11000 - 12000 If it is not, proceed to the next step 3).	
3) Find idle maximum speed			Adjust L mixture needle to maximum idle speed.*2	
4) Set idle maximum speed w/ TAS	r/min		3950	
5) Set idle speed by turning L mixture needle CCW	r/min		3000	
6) Confirm H mixture needle position before WOT setting			Turn H mixture needle CCW to confirm engine speed reduces less than or equal to 11000 r/min.	
7) WOT setting			Turn H mixture needle CW in 1/8 turn increment with the engine at idle, then accelerate to WOT and check engine speed. The final engine speed should fall within r/min 11400 - 12200 11900 - 12700 11000 - 12000	
8) Verify final engine speed with standard equipment	r/min		Idle: 2700 - 3500 WOT: 11400 - 12200 WOT: 11900 - 12700 WOT: 11000 - 12000	
Chain oil discharge volume	mL/min(UK.fl.oz./min)		Fixed: 6 (0.20)	

BTDC: Before top dead center. **WOT:** Wide open throttle **CCW:** Counterclockwise **TAS:** Throttle adjust screw

*1 Turn TAS clockwise until lightly seated. Then turn TAS counterclockwise.

*2 If clutch engages during adjustment process 2), reduce engine speed by turning TAS CCW until clutch disengages and then redo 2).

1-3 Torque limits and Special maintenance materials

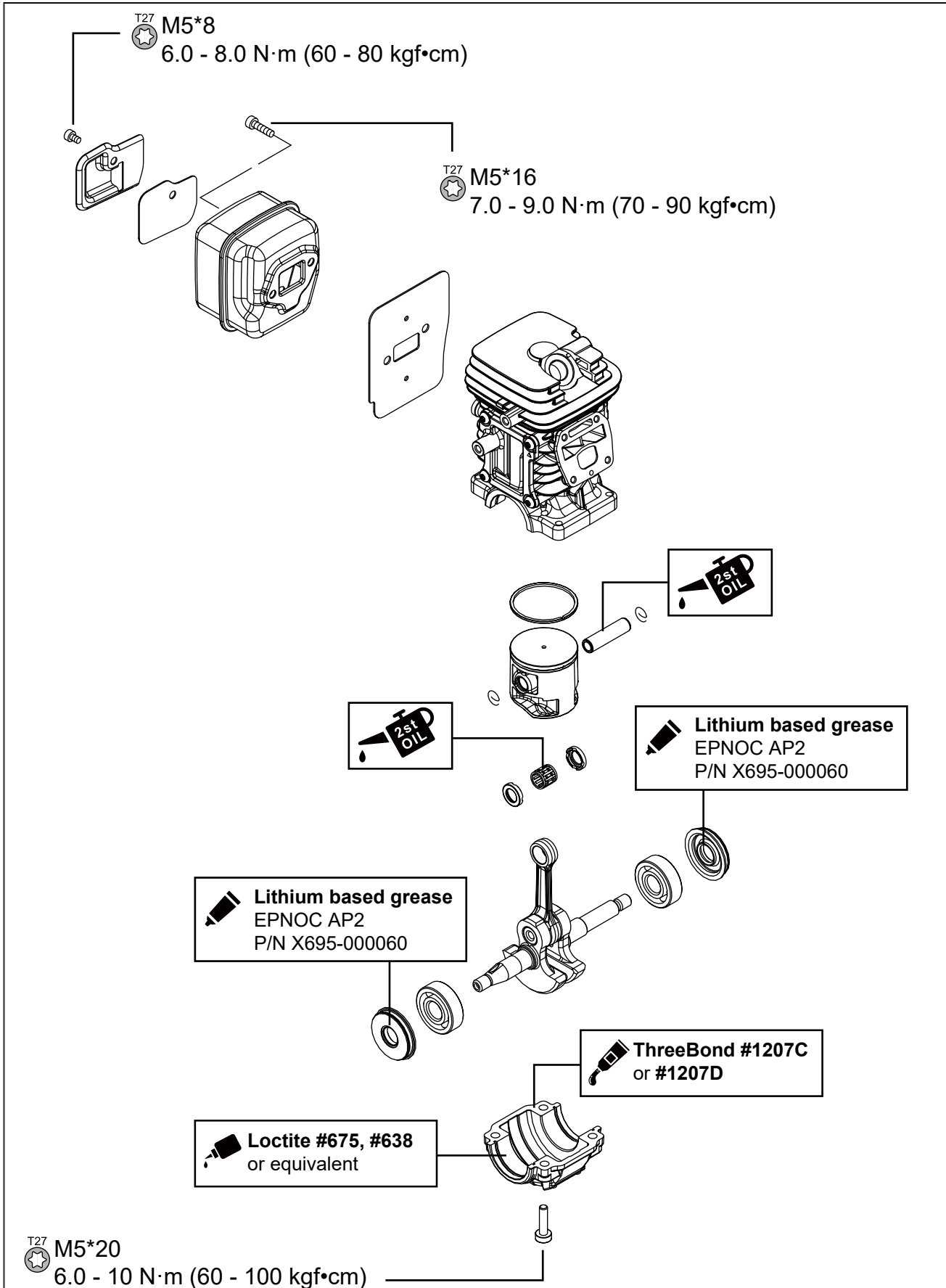

1-3 Torque limits and Special maintenance materials (Continued)

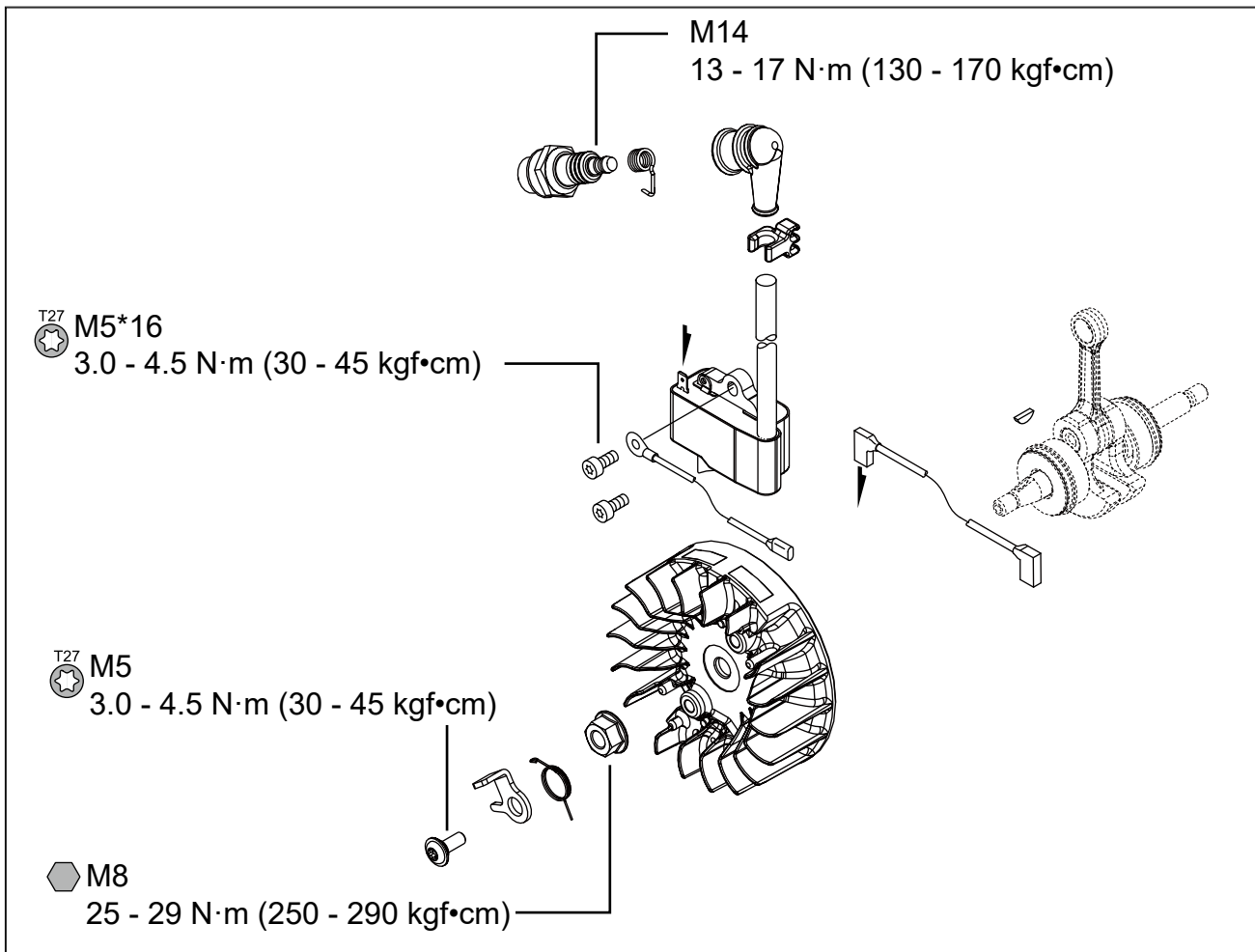
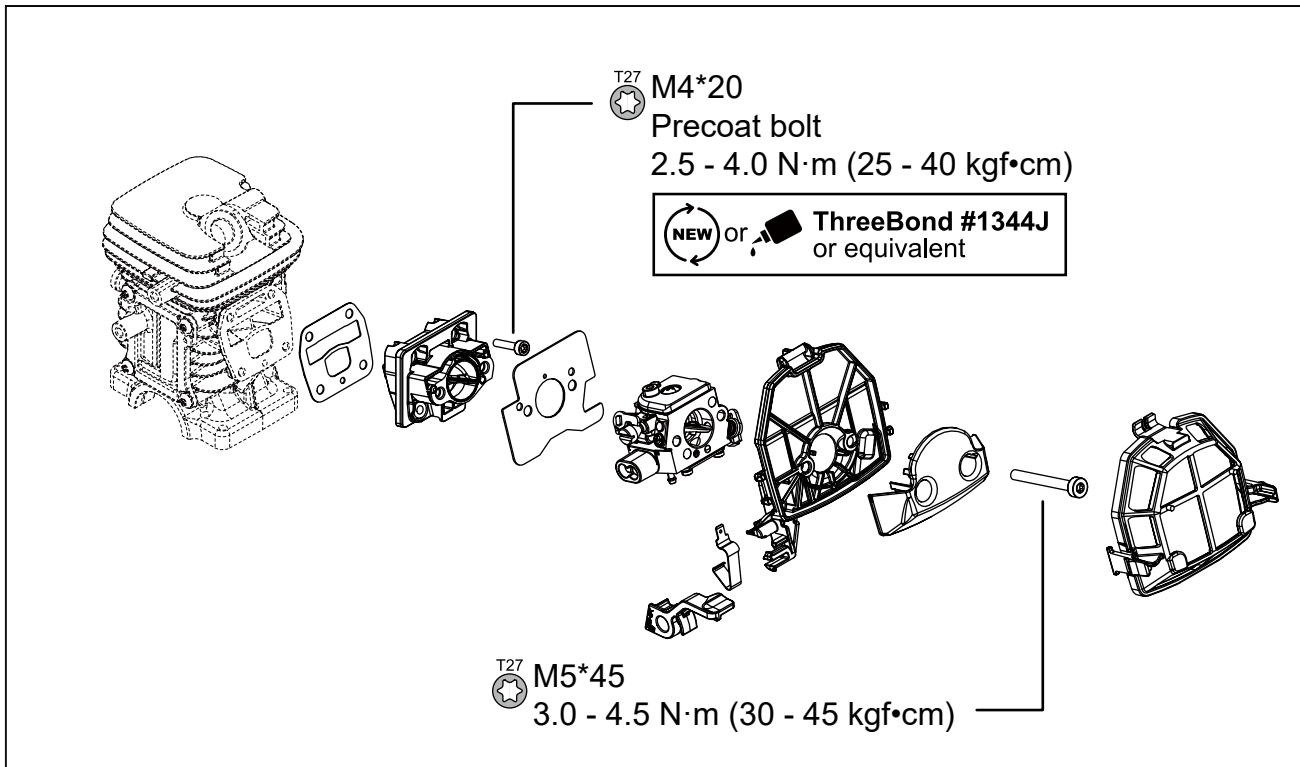

1-3 Torque limits and Special maintenance materials (Continued)

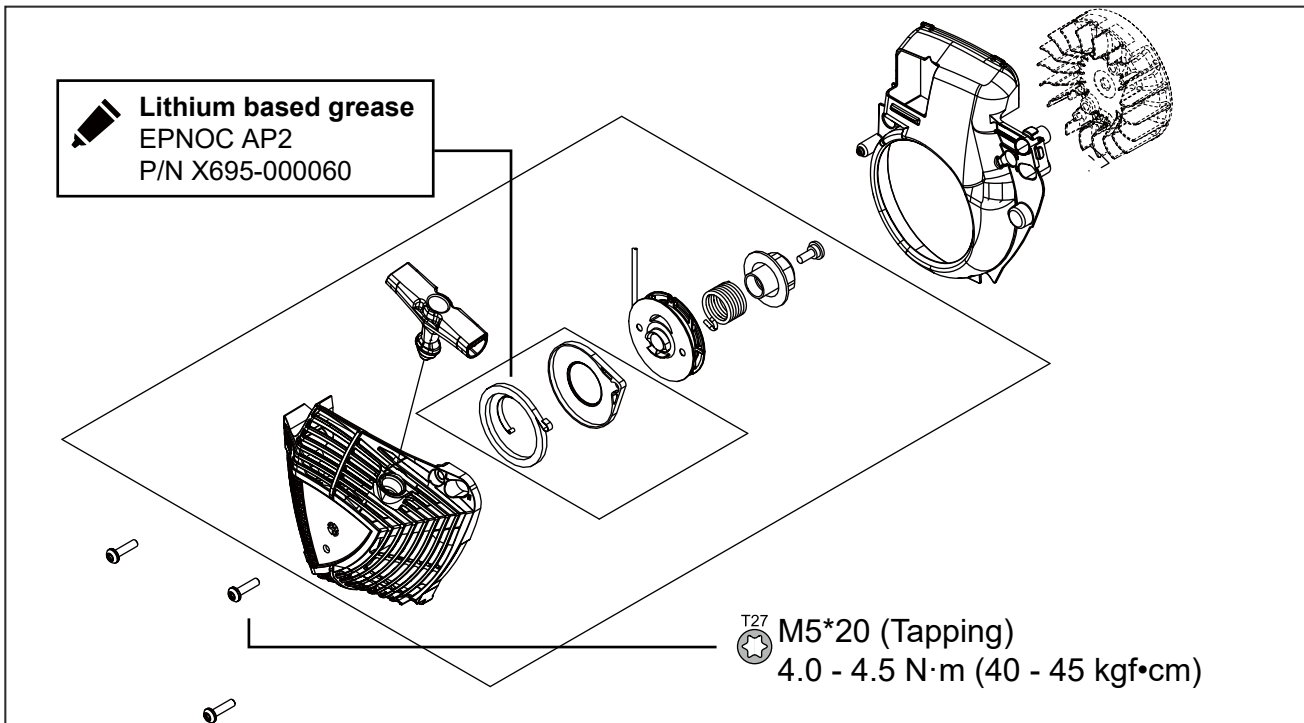
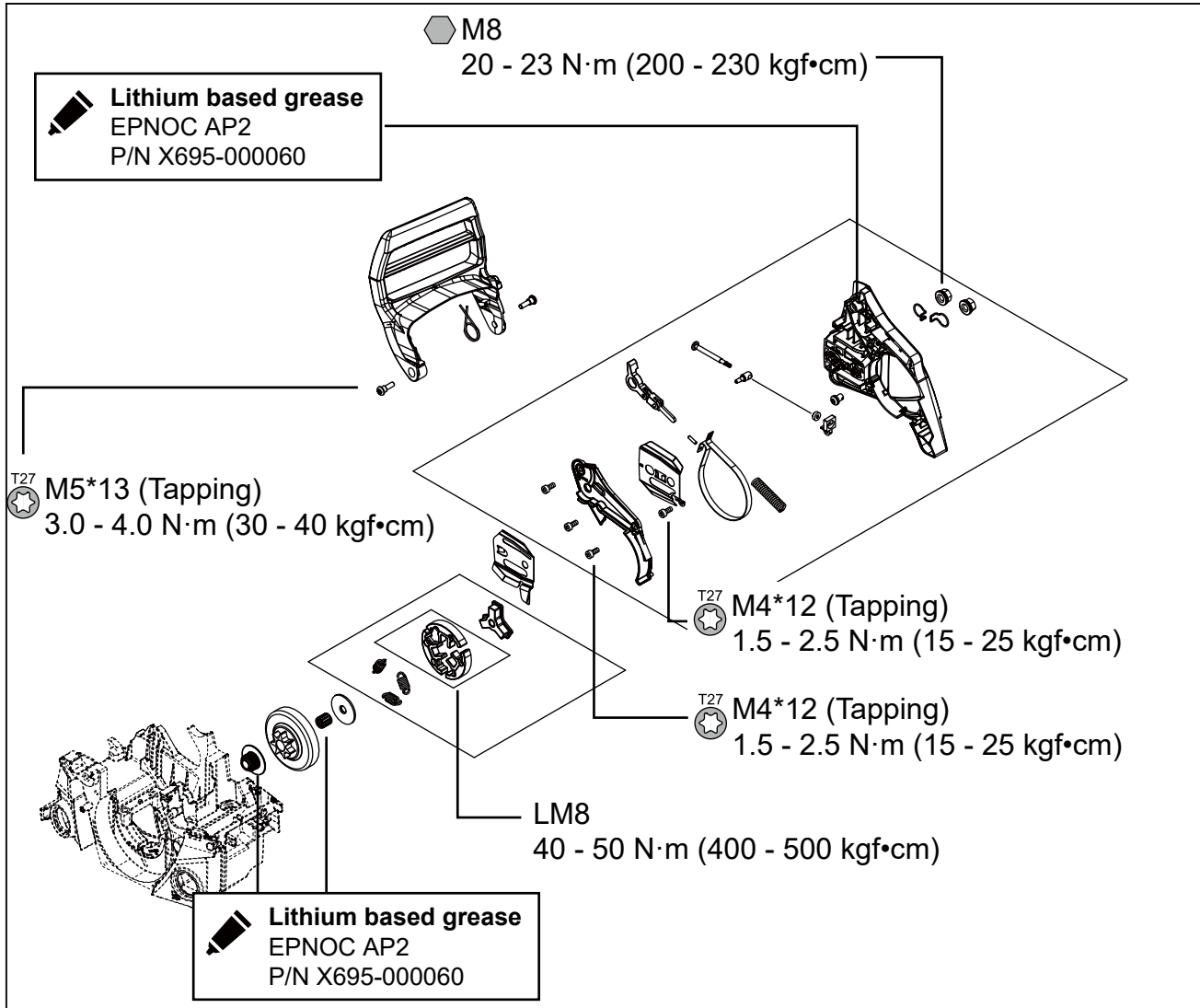

1-3 Torque limits and Special maintenance materials (Continued)

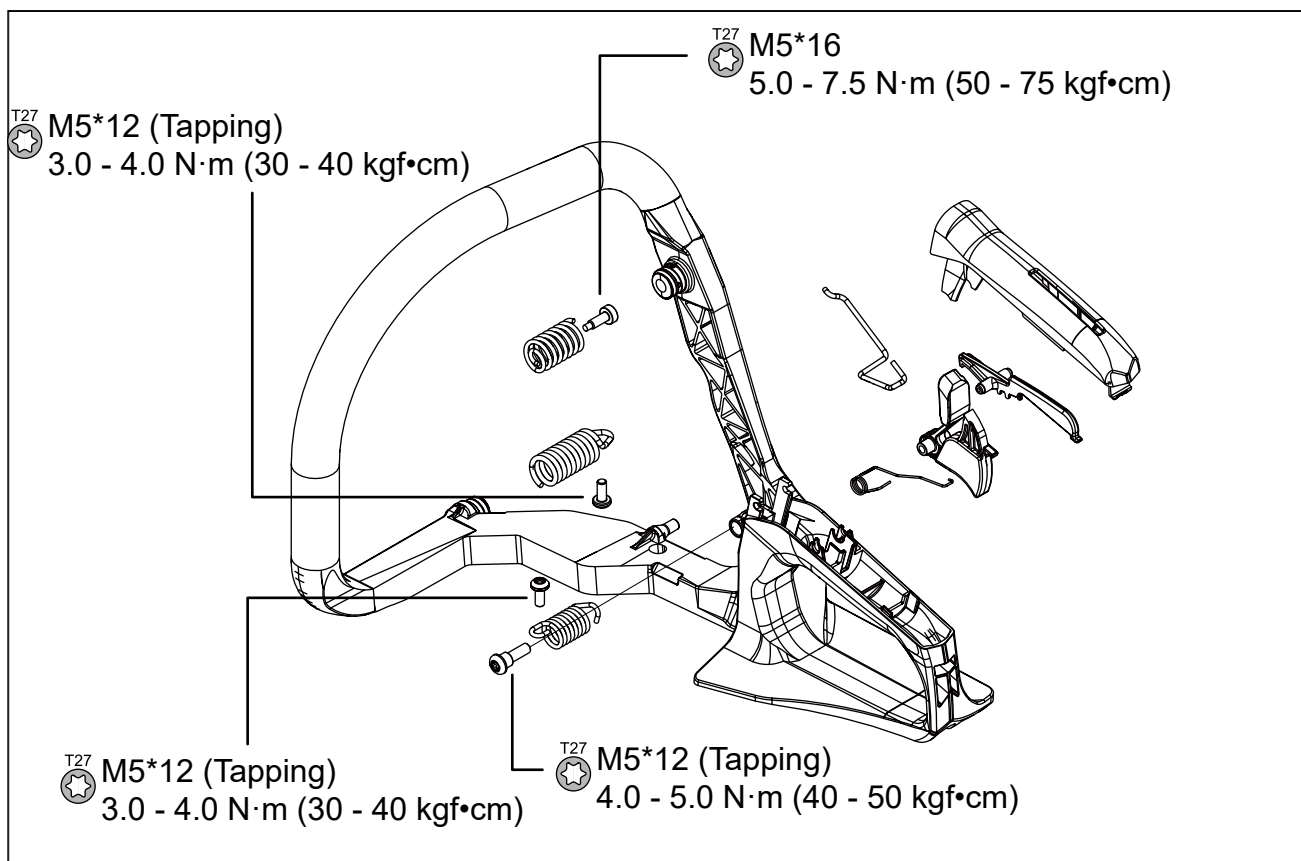
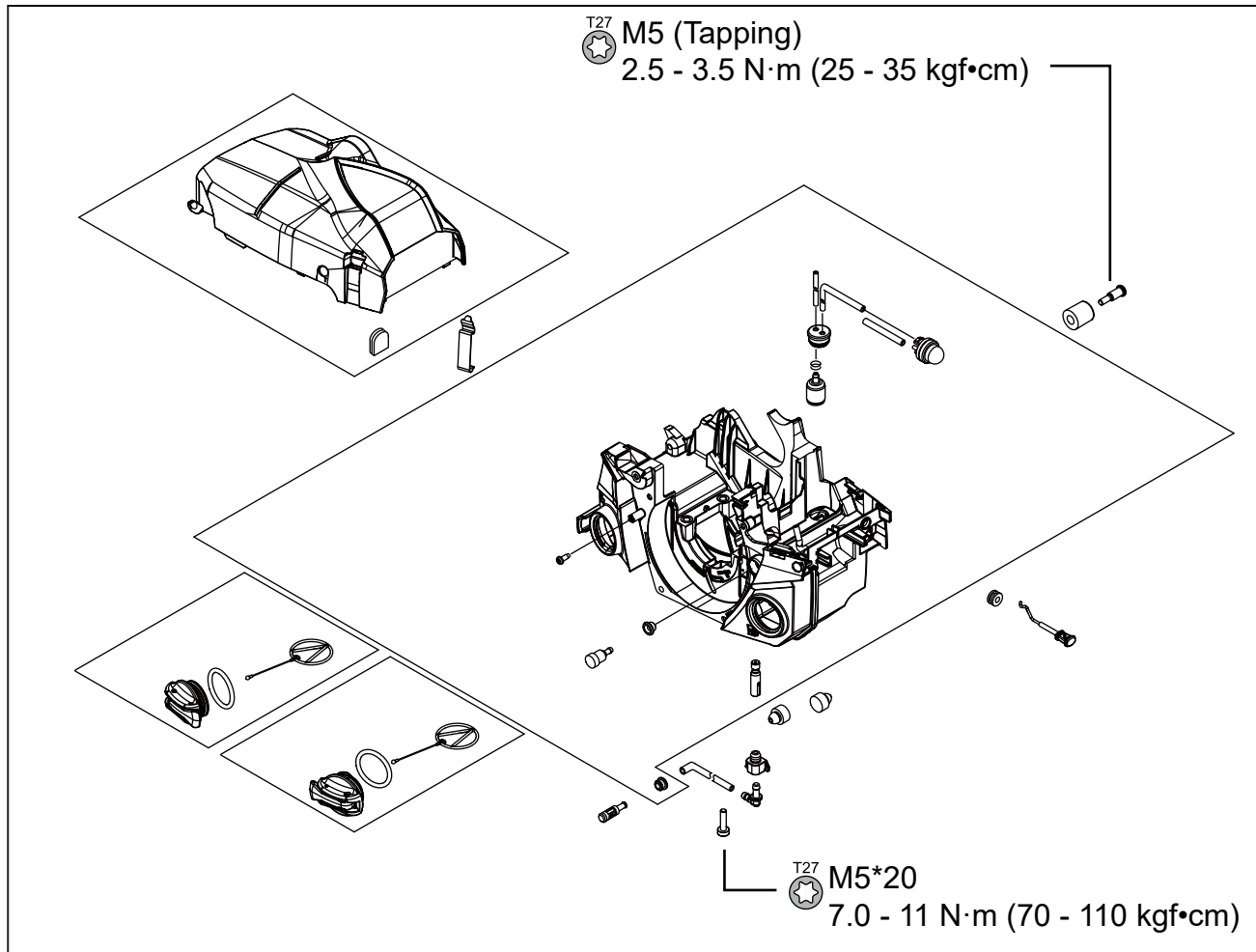

1-4 Service Limits

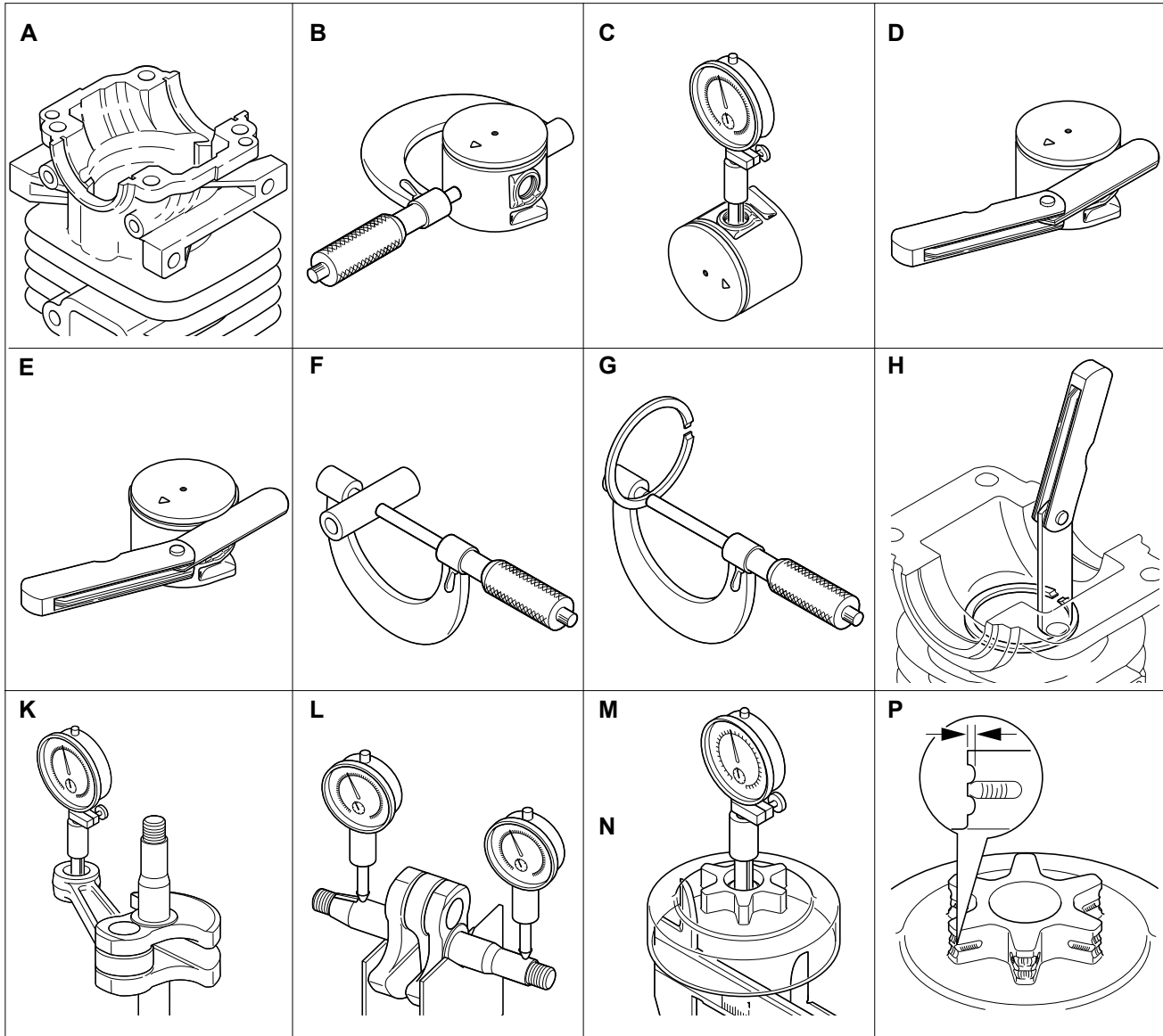

Description		mm (in)	
A	Cylinder bore	When plating is worn and aluminium can be seen	
B	Piston outer diameter	Min.	41.90 (1.650)
C	Piston pin bore	Max.	9.035 (0.3557)
D	Piston ring groove	Max.	1.6 (0.063)
E	Piston ring side clearance	Max.	0.1 (0.004)
F	Piston pin outer diameter	Min.	8.98 (0.3535)
G	Piston ring width	Min.	1.45 (0.057)
H	Piston ring end gap	Max.	0.5 (0.02)
K	Con-rod small end bore	Max.	12.025 (0.4734)
L	Crankshaft runout	Max.	0.05 (0.002)
M	Sprocket bore	Max.	12.80 (0.5039)
N	Clutch drum bore	Max.	70.5 (2.78)
P	Sprocket wear limit	Max.	0.5 (0.02)

1-5 Special tools

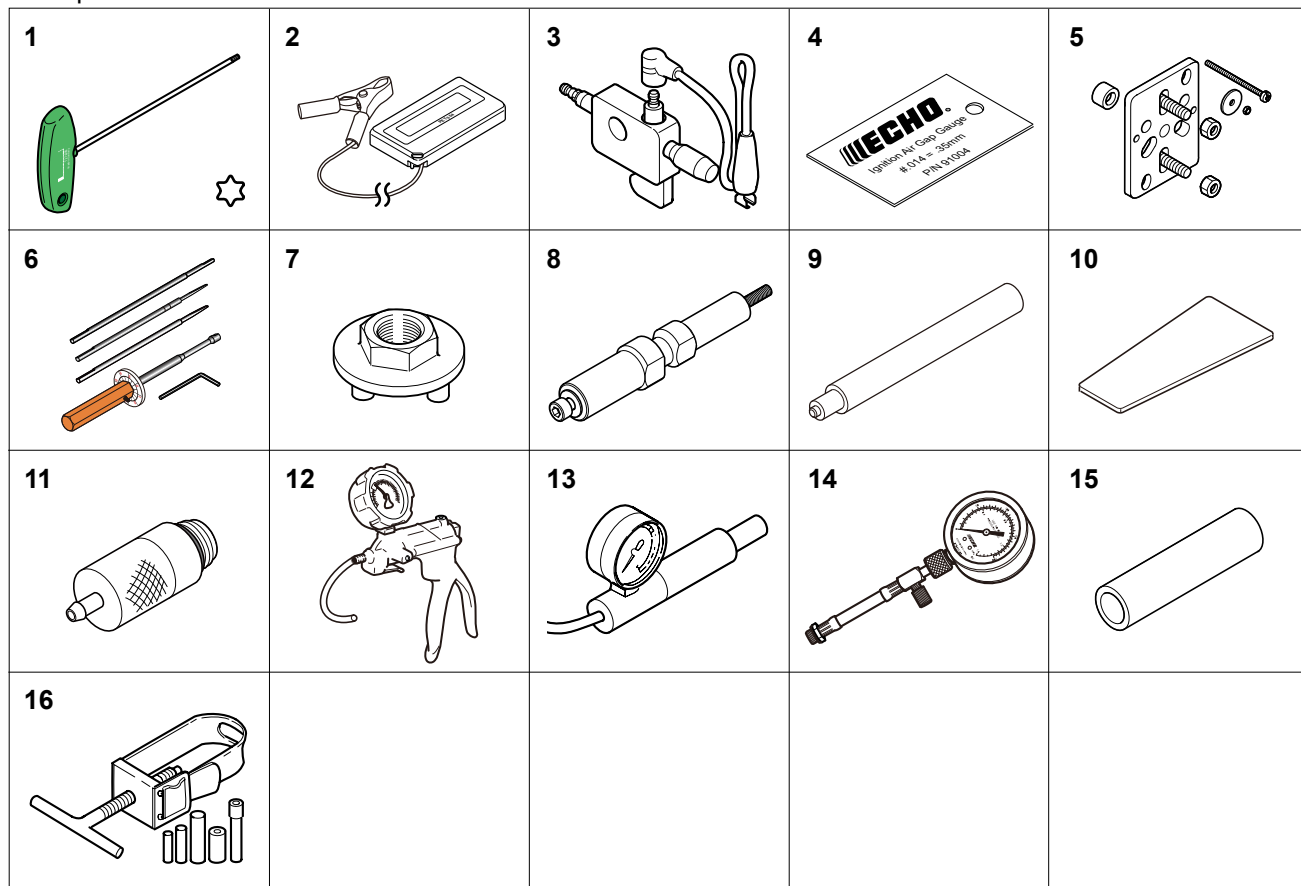

Key	Part Number	Description	Reference
1	X602-000340	Torx wrench (T27)	Removing and installing torx bolts
2	PET304	Tachometer PET-304	Measuring engine speed to adjust carburetor
3	897800-79931	Spark tester	Checking ignition system
4	91004	Module air gap gauge	Adjusting pole shoe air gaps
5	Y089-000111	Puller	Removing magneto rotor (flywheel) and crankcase
6	Y089-000095	Carburetor adjustment tool	Adjusting carburetor
7	897505-16133	Clutch Tool	Removing and installing clutch assembly
8	Y089-000131	Auto-oiler puller	Removing pencil type autooiler
9	91073A	Auto-oiler installer	Installing pencil type autooiler
10	91041	Pressure rubber plug	Plugging exhaust/intake port to test crankcase/cylinder leakages
11	A131-000150	Pressure connector	Testing crankcase and cylinder leakage
12	91149	Pressure / vacuum tester	Testing crankcase and cylinder leakage
13	897803-30133	Pressure tester	Testing carburetor and crankcase leakage
14	91037	Compression gauge	Measuring cylinder compression
15	897726-21430	Oil seal tool	Installing ball bearings
16	897702-30131	Piston pin tool	Removing and installing piston pin