

# CS-2511TES\_25C

Serial Number

37001001-99999999

Last updated date

03/Jul/2023



## TABLE OF CONTENTS

---

CYLINDER, PISTON, CRANKSHAFT .....	1
ENGINE COVER.....	3
MAGNETO.....	5
AIR CLEANER, CARBURETOR.....	7
CARBURETOR.....	9
MUFFLER.....	11
RECOIL STARTER.....	13
HANDLE.....	15
CHAIN BRAKE.....	17
ACCESSORIES .....	19
OILER.....	21
GUIDE BAR, CHAIN.....	23
OPTION PARTS.....	25

# CYLINDER, PISTON, CRANKSHAFT

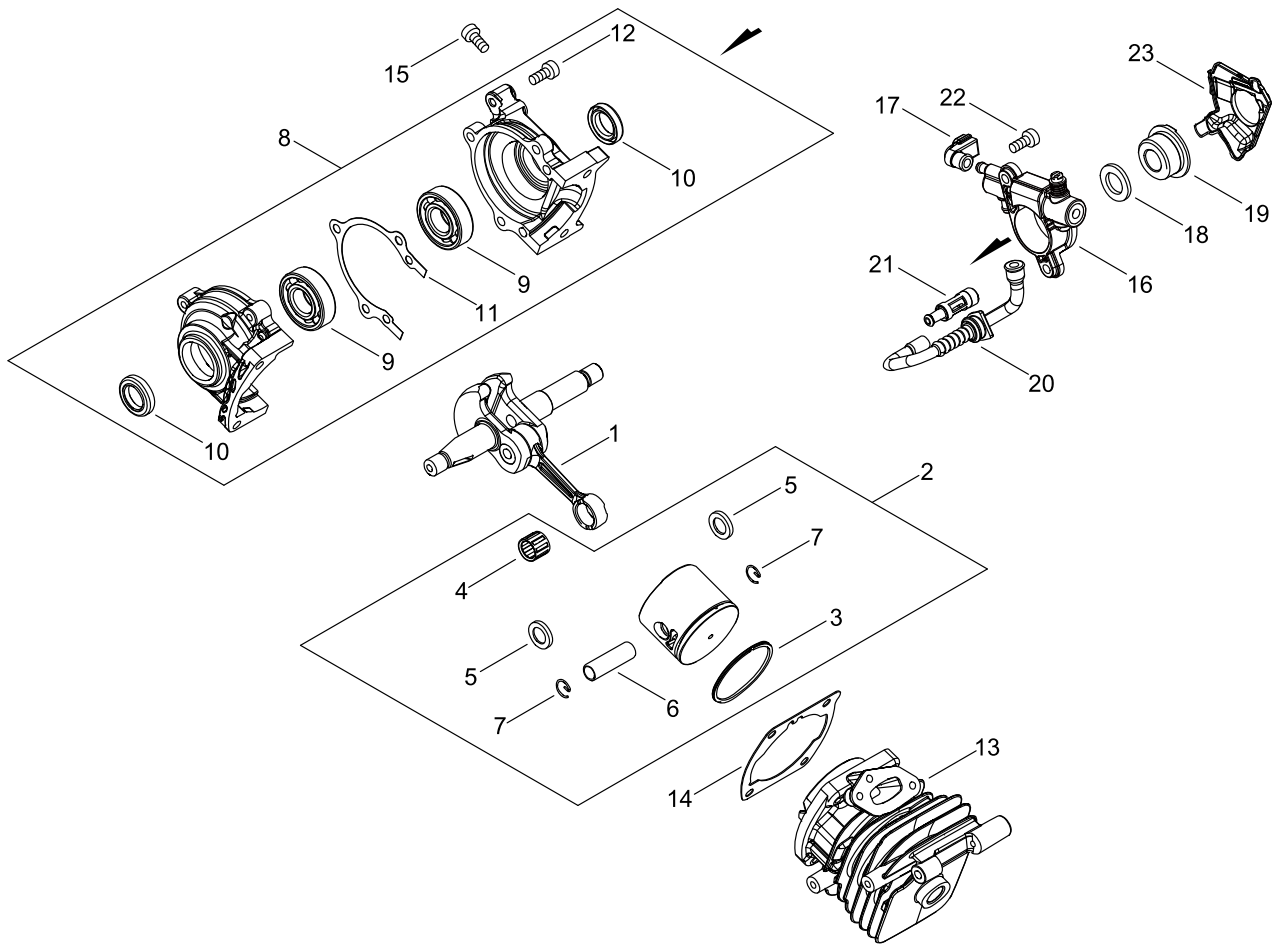

## CYLINDER, PISTON, CRANKSHAFT

Key No.	LV (+)	Parts Number	Parts Description	Qty	Standard	Class
1		A011-001440	CRANKSHAFT,ASM	1		D
2		P021-050120	PISTON KIT	1		D
3	+	A101-000700	RING, PISTON	1	35*B1.2*T1.6	B
4	+	V553-000020	BEARING,NEEDLE 8	1	KBK8X11X8.8X4	B
5	+	100014-55930	SPACER, PISTON PIN	2		C
6	+	V606-000020	PIN,ENG 8	1	5.8*8*25.5	D
7	+	100015-04630	CIRCLIP, PISTON PIN	2		C
8		P021-050130	CRANKCASE SET	1		D
9	+	900800-36001	BEARING, BALL	2	6001	
10	+	V505-000070	OIL SEAL	2		C
11	+	V102-000290	GASKET,CRANKCASE	1	T0.3	B
12	+	V804-000100	BOLT, TORX 4	3	TB-4*16 12.9	C
13		P021-051920	CYLINDER	1		D
14		V100-000830	GASKET,CYL	1	T0.5	B
15		V804-000100	BOLT, TORX 4	4	TB-4*16 12.9	C
16		C022-000211	AUTO-OILER ASSEMBLY	1	OP-27C(B)	C
17		V470-002171	PIPE	1		C
18		V308-000030	WASHER,CIRCULAR 11	1	10.5*17.4*1.8	C
19		V652-000230	GEAR,WORM	1		B
20		V470-002200	PIPE	1		C
21		P021-050140	STRAINER, OIL ASY	1		C
22		V804-000050	BOLT, TORX 4	2	TB-4*12 10.9	C
23		C236-000150	COVER,OILER	1		D

Class : Consumable class

A:Fast moving parts B:Semi-fast moving parts C:Slow moving parts D:Order only as needed

# ENGINE COVER

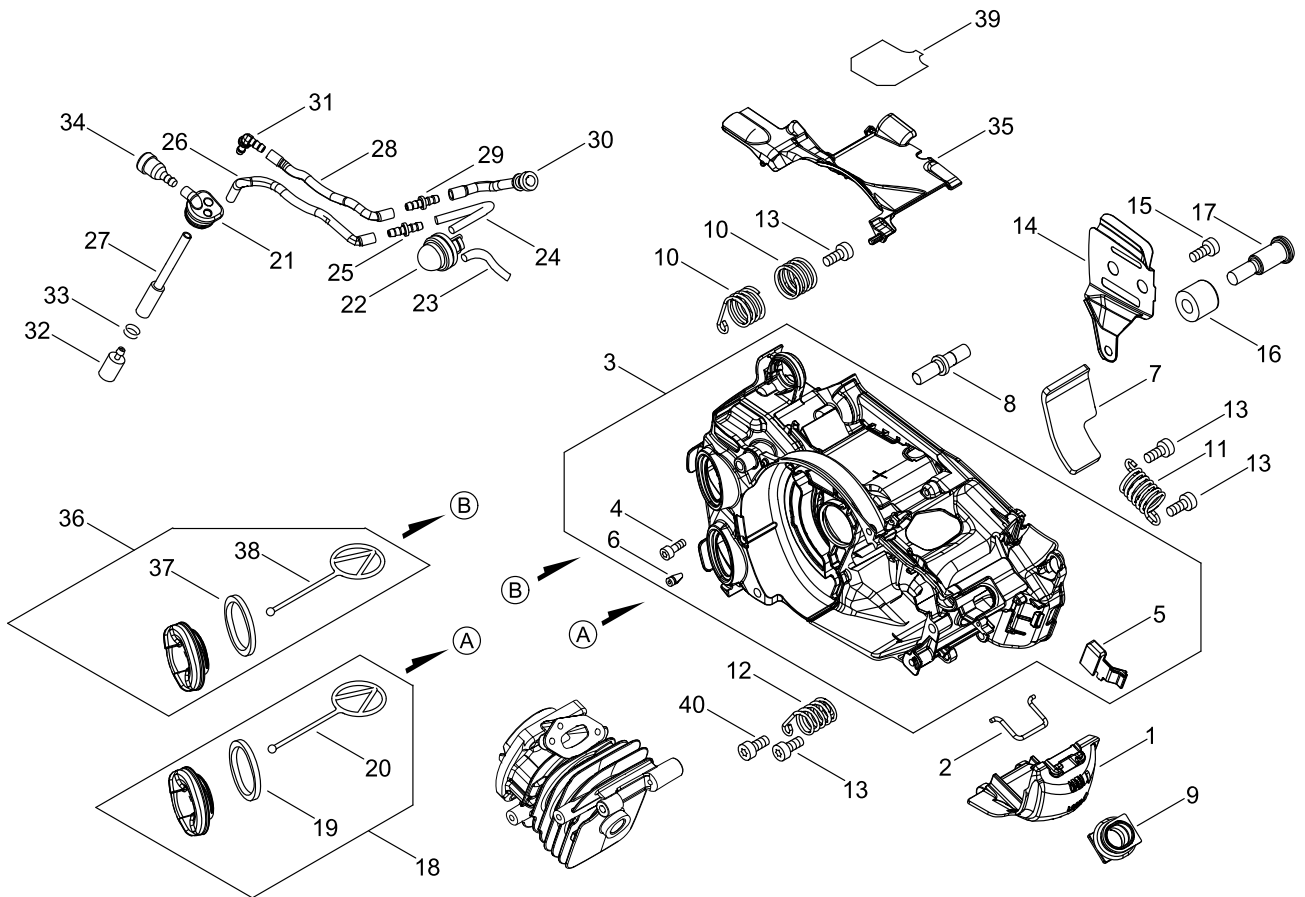

## ENGINE COVER

Key No.	LV (+)	Parts Number	Parts Description	Qty	Standard	Class
1		A429-000200	COVER,CAP	1		C
2		C649-000440	HOOK	1		D
3		P021-051910	ENGINE COVER ASY	1		
4	+	V804-000100	BOLT, TORX 4	3	TB-4*16 12.9	C
5	+	A219-000071	SHUTTER, AIR	1		C
6	+	436114-13930	VALVE, CHECK	1		B
7		V341-000200	WASHER,SQUARE	1		C
8		V225-000262	BOLT,STUD 8	1		C
9		A239-000110	PIPE, INTAKE	1		C
10		V450-002050	SPRING,COMPRESSION	2		B
11		V450-002060	SPRING,COMPRESSION	1		B
12		V450-002070	SPRING,COMPRESSION	1		B
13		V804-000000	BOLT, TORX 4	4	TT-4*12 DG 10.9	C
14		C305-000490	PLATE,SPROCKET GUARD	1	T0.3	C
15		V203-002280	BOLT,5	1		C
16		C310-000140	CATCHER, CHAIN	1		B
17		V203-002260	BOLT,5	1		C
18		A033-000390	OIL,CAP	1		B
19	+	V107-000180	GASKET,FUEL CAP	1		A
20	+	A365-000050	CONNECTOR,CAP	1		B
21		V137-000140	GROMMET,FUEL	1		C
22		A035-000040	PUMP, FUEL	1	188-554-A	A
23		V470-002180	PIPE	1		C
24		V471-004870	PIPE	1	3*5*58L	C
25		V186-000020	JOINT,PIPE	1		C
26		V471-003660	PIPE	1		C
27		V470-002210	PIPE	1		C
28		V471-003820	PIPE	1	3*5*95	C
29		V186-000510	JOINT,PIPE	1		C
30		V470-002190	PIPE	1		C
31		V186-000530	JOINT,PIPE	1		C
32		A369-000420	STRAINER, FUEL	1	ES-16499	A
33		V490-000500	CLIP	1		C
34		131300-56431	VENT ASSEMBLY, FUEL	1		B
35		A127-000450	COVER,DUST	1		C
36		A033-000410	CAP,FUEL	1		B
37	+	V107-000180	GASKET,FUEL CAP	1		A
38	+	A365-000050	CONNECTOR,CAP	1		B
39		X505-008600	LABEL,CAUTION	1	CE(112DB)	D
40		V804-000010	BOLT, TORX 4	1	TT-4*16 DG 10.9	C

Class : Consumable class

A:Fast moving parts B:Semi-fast moving parts C:Slow moving parts D:Order only as needed

# MAGNETO

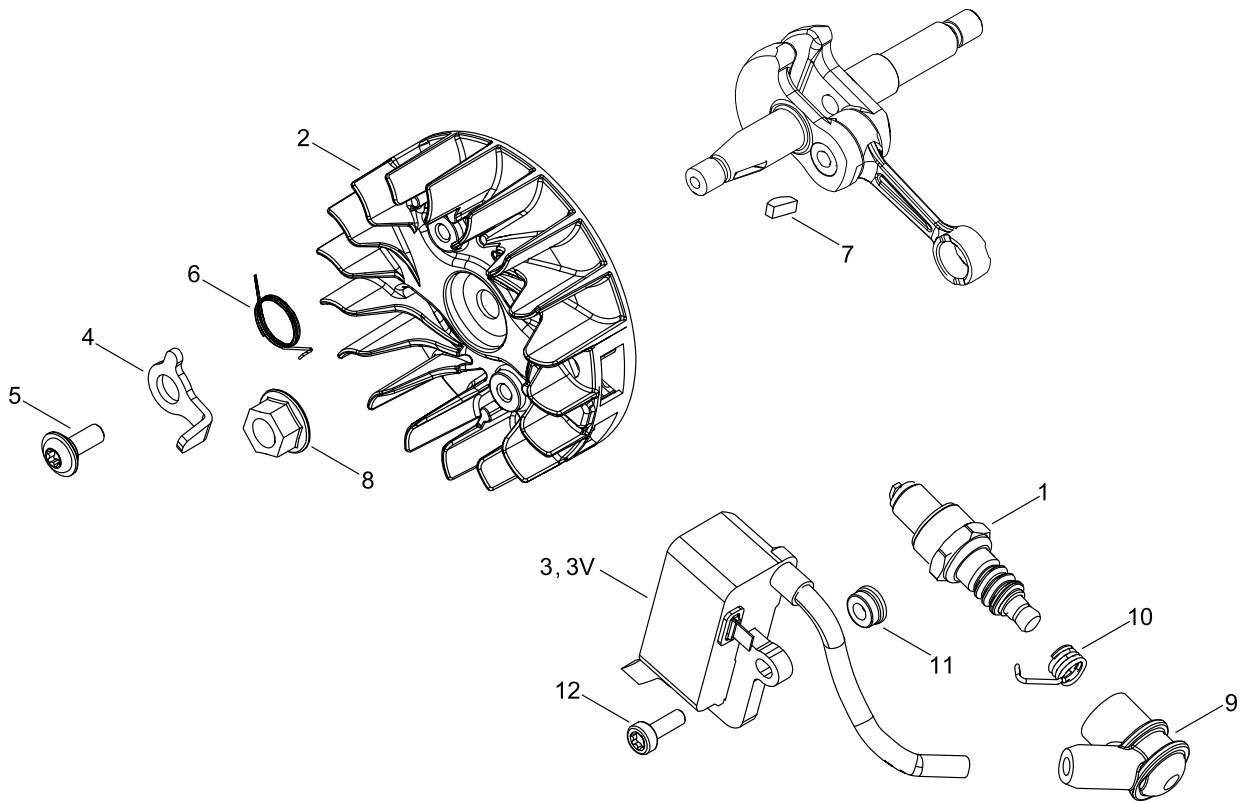



## MAGNETO

Key No.	LV (+)	Parts Number	Parts Description	Qty	Standard	Class
1		A425-000060	SPARKPLUG	1	CMR7H	A
2		A409-001300	ROTOR, MAGNETO	1		C
3		P021-050160	COIL, IGNITION	1		C
3V		P100-006570	COIL, IGNITION	1		C
4		A514-000300	PAWL	2		C
5		V203-002250	BOLT,5	2		C
6		V452-000030	SPRING,TORSION	2		B
7		100142-12330	KEY, WOODRUFF	1		C
8		V265-000140	NUT	1		C
9		A427-000190	CAP,SPARK PLUG	1		C
10		A426-000010	TERMINAL,SPARKPLUG	1		C
11		V352-000300	COLLAR,4	2	4.5*8.3*4.6L	C
12		V804-000060	BOLT, TORX 4	2	TB-4*16 10.9	C

Class : Consumable class

A:Fast moving parts B:Semi-fast moving parts C:Slow moving parts D:Order only as needed

# AIR CLEANER, CARBURETOR

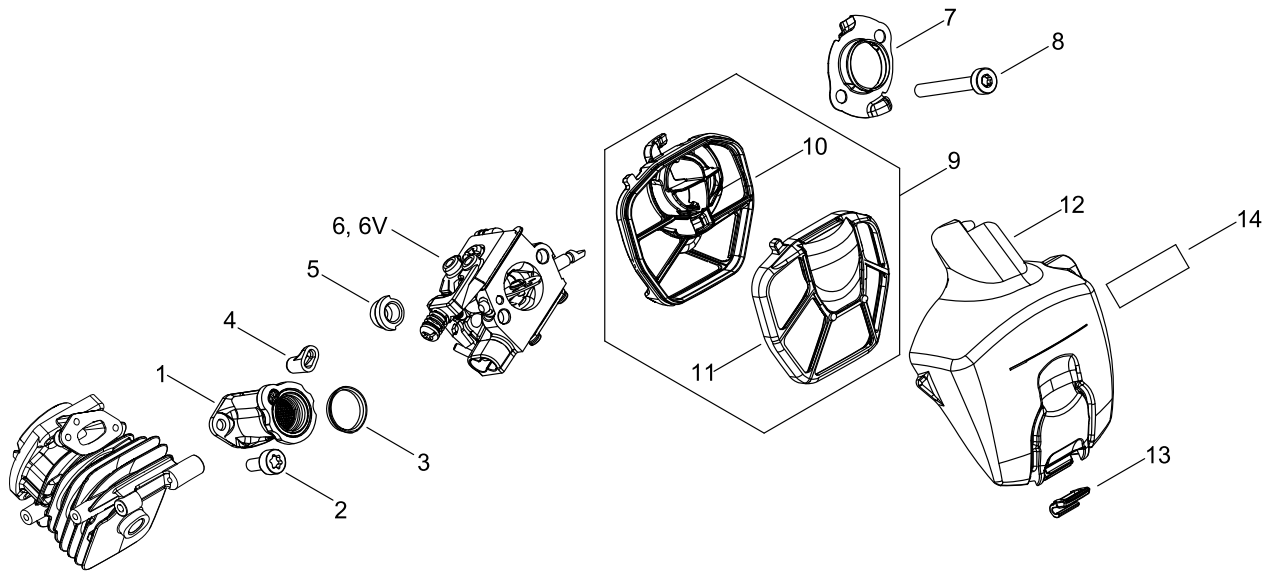

## AIR CLEANER, CARBURETOR

Key No.	LV (+)	Parts Number	Parts Description	Qty	Standard	Class
1		A202-000290	BELLOWS, INTAKE	1		C
2		V804-000040	BOLT, TORX 4	2	TB-4*10 10.9	C
3		V358-000220	COLLAR,14	1	14*16*2.5	C
4		V351-000030	COLLAR,3	1		C
5		V162-000770	PLUG	2		C
6		A021-004520	CARBURETOR,DIAPHRAGM	1	WT-1153	B
6V		A021-005160	CARBURETOR,DIAPHRAGM	1		B
7		A204-000250	ELBOW, CARBURETOR	1	T:0.5	C
8		V805-000070	BOLT, TORX 5	2	TB-5*40 10.9	C
9		A226-002140	ELEMENT, AIR FILTER	1	NYLON MESH	A
10	+	A226-002120	ELEMENT, AIR FILTER	1		A
11	+	A226-002130	ELEMENT, AIR FILTER	1		A
12		A232-001842	LID,CLEANER	1		C
13		A235-000410	KNOB,CLEANER LID	1		C
14		X503-014140	LABEL,MODEL	1	CS-2511TES	D

Class : Consumable class

A:Fast moving parts B:Semi-fast moving parts C:Slow moving parts D:Order only as needed

# CARBURETOR

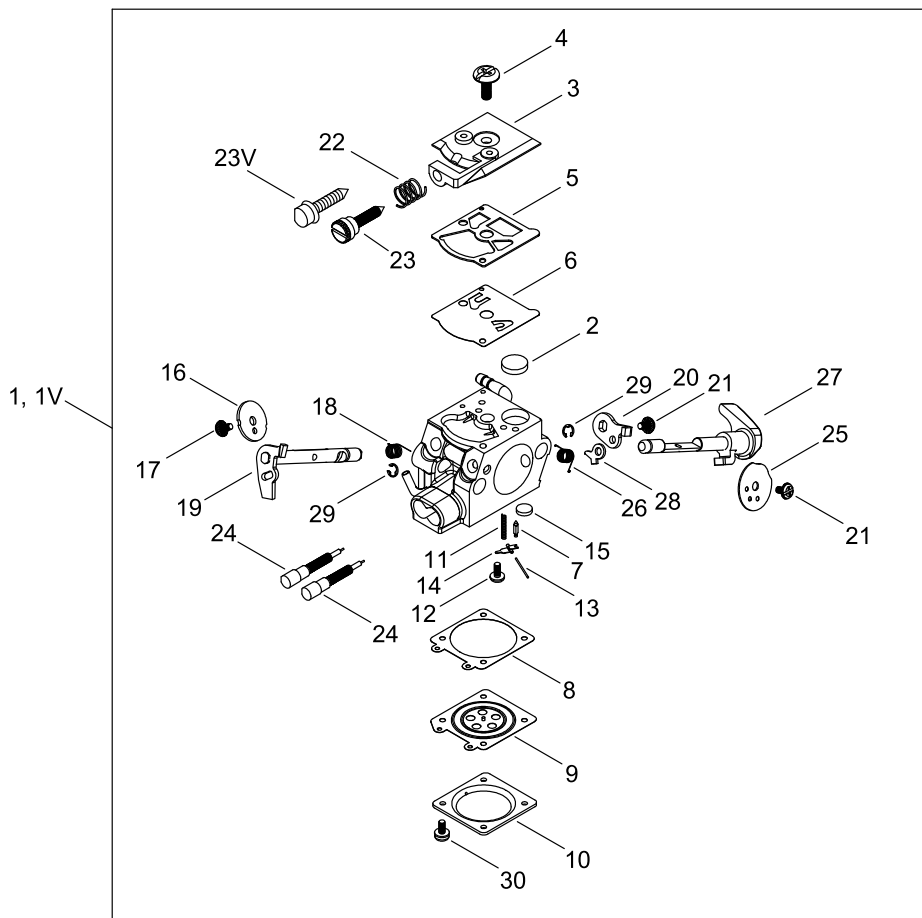

## CARBURETOR

Key No.	LV (+)	Parts Number	Parts Description	Qty	Standard	Class
1		A021-004520	CARBURETOR,DIAPHRAGM	1	WT-1153	B
1V		A021-005160	CARBURETOR,DIAPHRAGM	1		B
2	+	123126-10631	SCREEN, INLET	1		B
3	+	123124-02960	COVER, FUEL PUMP	1		D
4	+	123110-03930	SCREW, PUMP COVER	1		D
5	+	123125-15030	GASKET, FUEL PUMP	1		A
6	+	123112-15030	DIAPHRAGM, FUEL PUMP	1		A
7	+	123137-19830	VALVE, INLET NEEDLE	1		D
8	+	123140-27230	GASKET,M. DIAPHRAGM	1		A
9	+	P003-001850	DIAPHRAGM, METERING	1		A
10	+	123142-03930	COVER, M. DIAPHRAGM	1		D
11	+	123122-39830	SPRING, METER. LEVER	1		D
12	+	123139-03930	SCREW, M. LEVER PIN	1		D
13	+	123138-03930	PIN, METERING LEVER	1		D
14	+	123123-03930	LEVER, METERING	1		D
15	+	123146-10631	PLUG, WELCH	1		C
16	+	P003-005750	VALVE, THROTTLE	1		D
17	+	P003-002380	SCREW	1		D
18	+	123113-37530	SPRING, THROTTLE RTN	1		B
19	+	P003-001300	SHAFT, THROTTLE	1		C
20	+	P003-000380	THROTTLE, LEVER	1		D
21	+	123114-38830	SCREW	2		D
22	+	123133-04260	SPRING, IDLE ADJUST	1		D
23	+	123134-04260	SCREW, IDLE ADJUST	1		D
23V	+	P003-006290	SCREW, IDLE ADJUST	1		D
24	+	P003-004190	NEEDLE	2		D
25	+	P003-000410	VALVE CHOKE	1		D
26	+	P003-004780	SPRING	1		D
27	+	P003-005760	SHAFT-CHOKE	1		D
28	+	P003-001510	LEVER-FAST IDLE	1		D
29	+	123127-15030	RING	2		D
30	+	123130-02960	SCREW	4		D

Class : Consumable class

A:Fast moving parts B:Semi-fast moving parts C:Slow moving parts D:Order only as needed

# MUFFLER

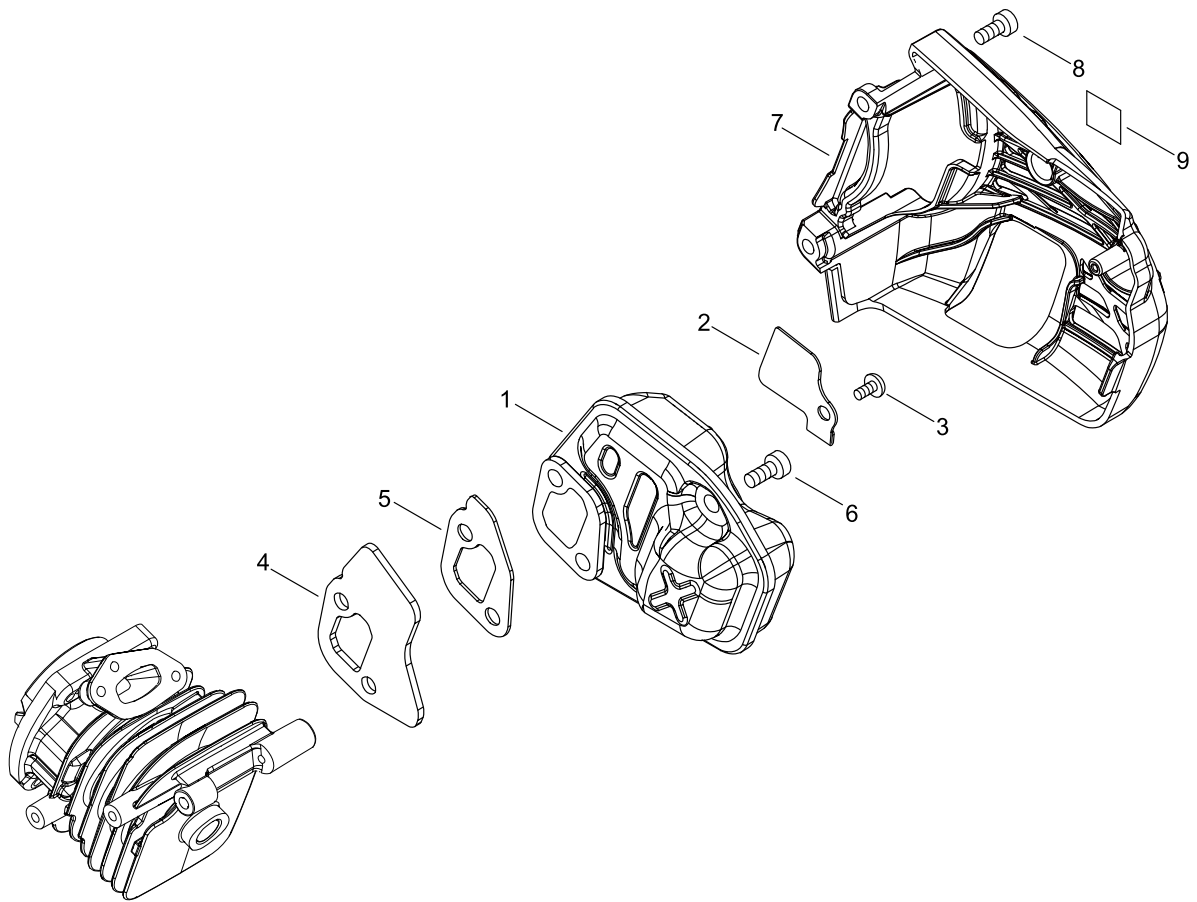

## MUFFLER

Key No.	LV (+)	Parts Number	Parts Description	Qty	Standard	Class
1		A030-000860	MUFFLER ASY	1		B
2		A310-000490	SCREEN, ARRESTOR	1		B
3		900216-04006	SCREW	1	4*6	
4		A312-000090	PLATE, EXHUST	1		C
5		V104-002290	GASKET,EXHAUST	1		A
6		V805-000150	BOLT, TORX 5	3	TB-5*16 10.9	C
7		A320-001210	COVER,MUFFLER	1	FOR CAT MUF	C
8		V804-000010	BOLT, TORX 4	2	TT-4*16 DG 10.9	C
9		X505-007710	LABEL,CAUTION	1		D

Class : Consumable class

A:Fast moving parts B:Semi-fast moving parts C:Slow moving parts D:Order only as needed

# RECOIL STARTER

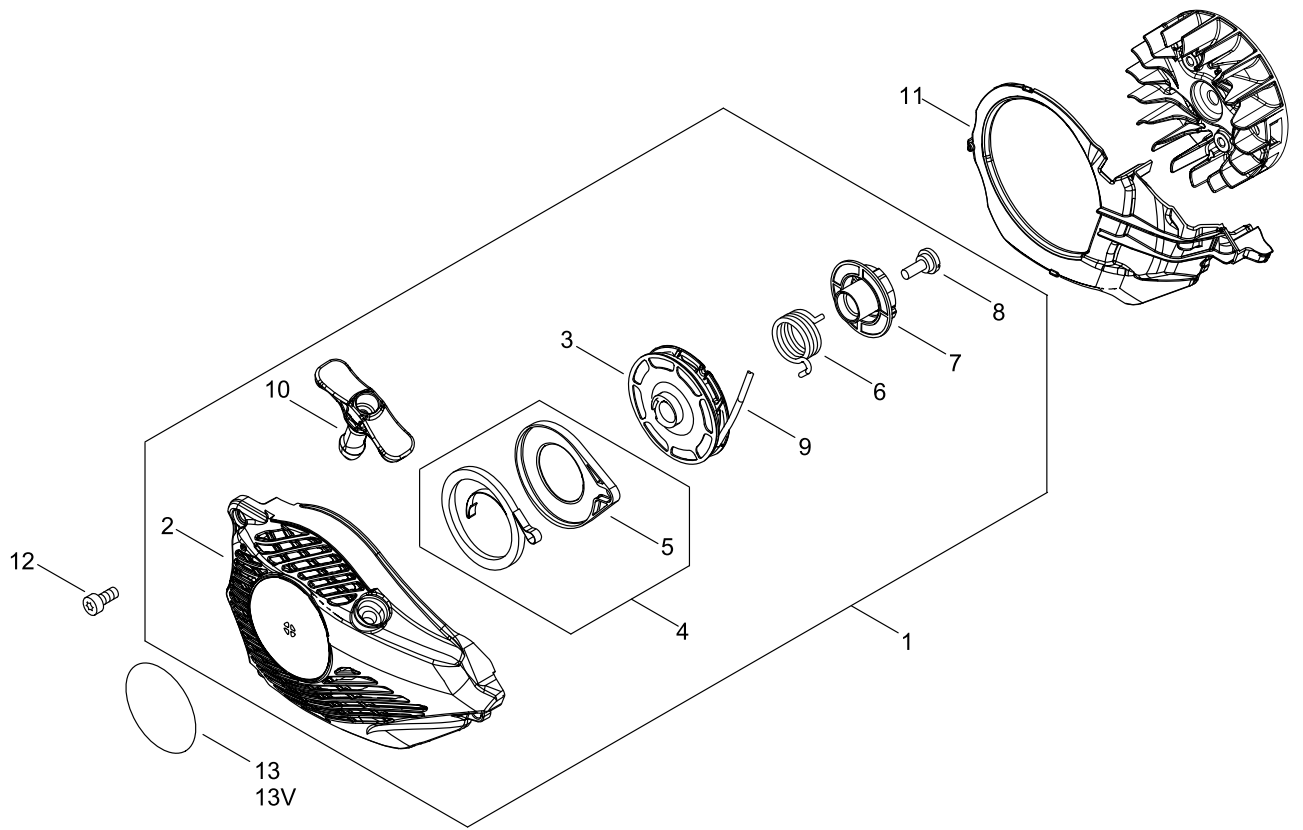



## RECOIL STARTER

Key No.	LV (+)	Parts Number	Parts Description	Qty	Standard	Class
1		A051-003131	STARTER,RECOIL ASY	1		B
2	+	P022-045300	CASE,STARTER ASY	1		C
3	+	P022-040050	DRUM	1		C
4	+	P022-040060	SPRING KIT, REWIND	1		B
5	++	P022-040070	SPRING CASE	1		C
6	+	P022-036670	SPRING,DAMPER	1		C
7	+	P022-040080	PLATE, CAM	1		C
8	+	177236-61830	SCREW	1		
9	+	P022-040090	ROPE, STARTER	1	3*700	B
10	+	P022-040100	GRIP, STARTER	1		
11		A172-003200	COVER,FAN	1		C
12		V804-000060	BOLT, TORX 4	3	TB-4*16 10.9	C
13		X502-001030	LABEL,ECHO	1	ECHO	D
13V		X502-001110	LABEL,ECHO	1	ECHO XSERIES	D

Class : Consumable class

A:Fast moving parts B:Semi-fast moving parts C:Slow moving parts D:Order only as needed

# HANDLE

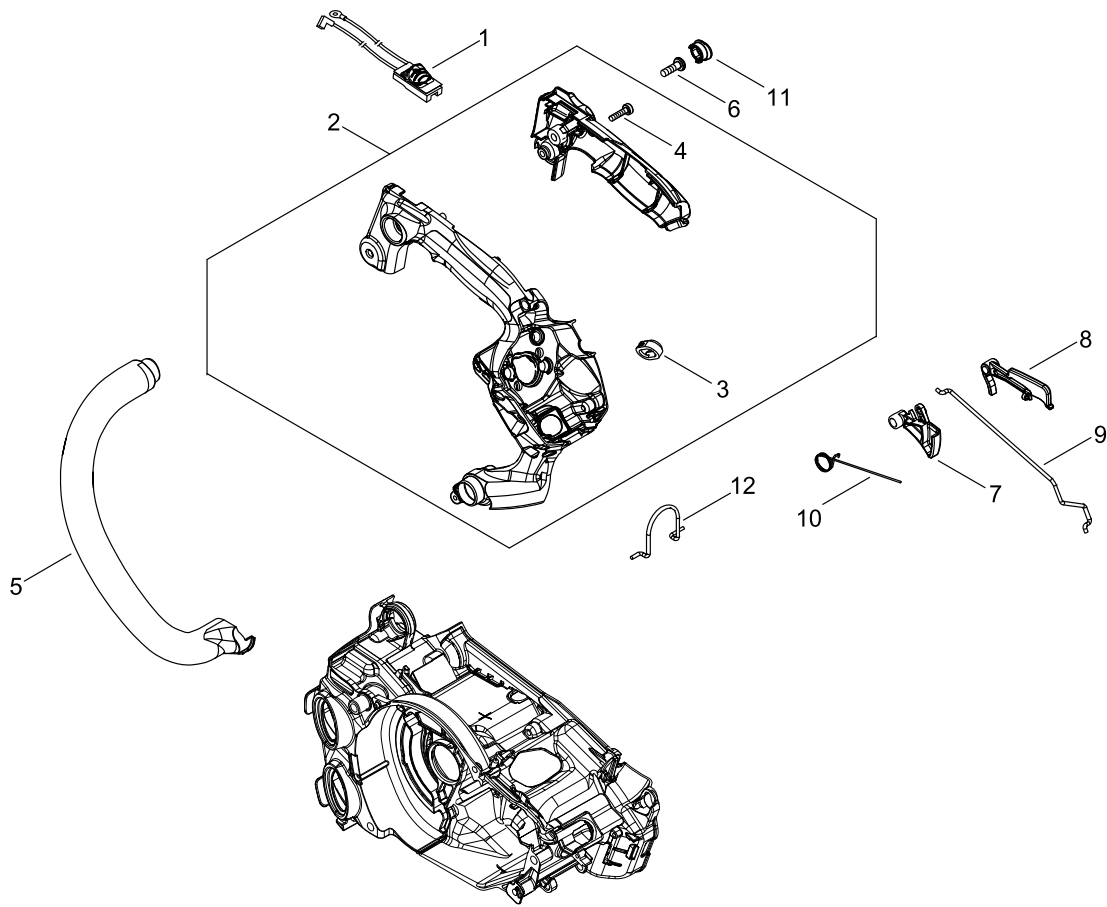

## HANDLE

Key No.	LV (+)	Parts Number	Parts Description	Qty	Standard	Class
1		A440-002741	SWITCH,ON OFF	1		C
2		P100-002151	HANDLE SET, REAR	1		C
3	+	V131-000220	GROMMET,NEEDLE	1		C
4	+	V804-000010	BOLT, TORX 4	1	TT-4*16 DG 10.9	C
5		C400-001550	HANDLE, FRONT	1		C
6		V805-000000	BOLT, TORX 5	1	TT-5*16 DG 10.9	C
7		C450-000950	CONTROL, THROTTLE	1		C
8		C460-000590	LOCKOUT, THROTTLE	1		C
9		C454-000540	ROD, THROTTLE	1		C
10		V452-001650	SPRING,TORSION	1		B
11		V162-000760	PLUG	1		C
12		C646-000132	RING,HARNESS	1		C

Class : Consumable class

A:Fast moving parts B:Semi-fast moving parts C:Slow moving parts D:Order only as needed

# CHAIN BRAKE

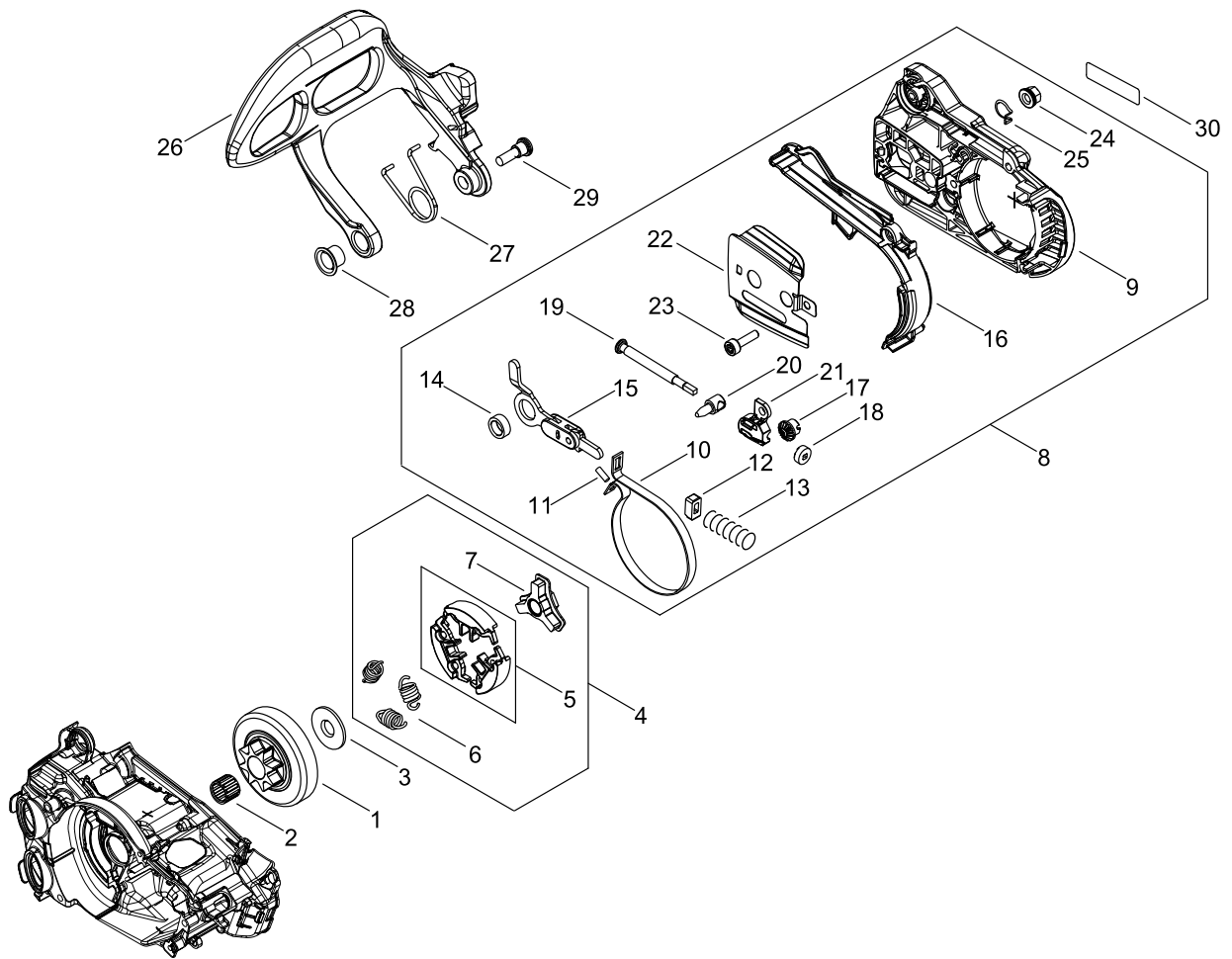

## CHAIN BRAKE

Key No.	LV (+)	Parts Number	Parts Description	Qty	Standard	Class
1		A556-001710	DRUM, CLUTCH	1	1/4	B
2		V555-000190	BEARING,NEEDLE 10	1	10*13*9.8	B
3		A551-000170	PLATE, CLUTCH	1		C
4		A056-000800	CLUTCH ASY	1		B
5	+	P021-050190	CLUTCH SHOE SET	1		
6	+	A566-000290	SPRING, CLUTCH	3		B
7	+	A552-000430	HUB, CLUTCH	1		B
8		P021-050202	GUARD, SPROCKET ASY	1		
9	+	C300-001112	GUARD, SPROCKET	1		C
10	+	C328-000330	BAND, BRAKE	1		C
11	+	93050-30080	ROLLER	1		C
12	+	V376-000450	SPACER	1		C
13	+	V450-002080	SPRING,COMPRESSION	1		B
14	+	V355-000860	COLLAR,8	1		C
15	+	C334-000340	CONNECTOR, BRAKE	1		C
16	+	C345-000640	COVER,BRAKE	1		C
17	+	V651-001060	GEAR,BEVEL	1		D
18	+	V651-000011	GEAR,BEVEL	1		D
19	+	V203-000041	BOLT,5	1		C
20	+	C309-000110	TENSIONER,CHAIN	1		C
21	+	V355-000840	COLLAR,8	1		C
22	+	C305-000500	PLATE,SPROCKET GUARD	1	T0.3	C
23	+	V804-000000	BOLT, TORX 4	3	TT-4*12 DG 10.9	C
24	+	V265-000550	NUT,8	1		C
25	+	C649-000420	HOOK	1		D
26		C320-000510	LEVER, BRAKE	1		C
27		V452-001660	SPRING,TORSION	1		B
28		V356-000780	COLLAR,10	1		C
29		V203-002270	BOLT,5	1		C
30		X502-000340	LABEL,ECHO	1	ECHO(WHITE)	D

Class : Consumable class

A:Fast moving parts B:Semi-fast moving parts C:Slow moving parts D:Order only as needed

# ACCESSORIES

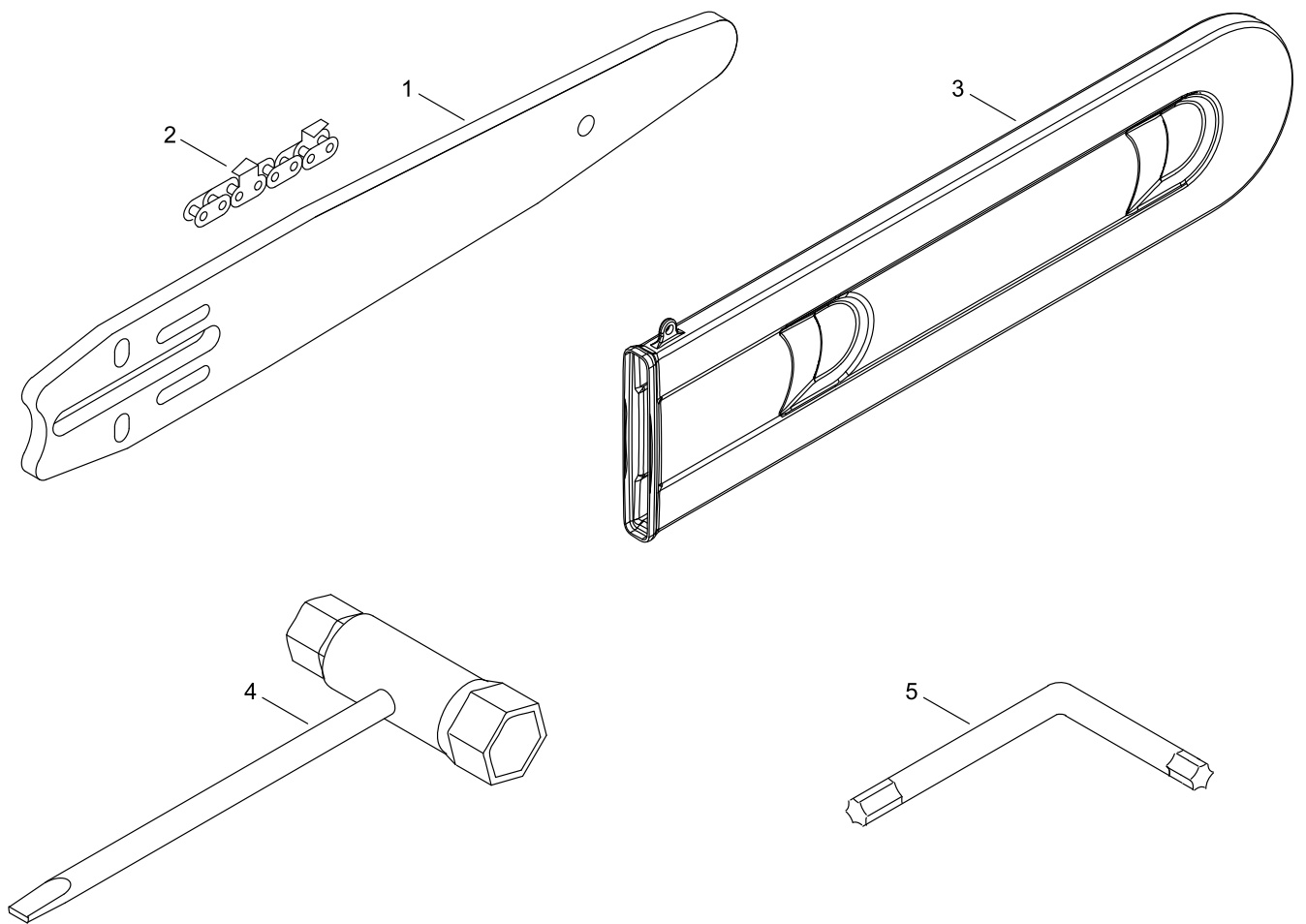

## ACCESSORIES

Key No.	LV (+)	Parts Number	Parts Description	Qty	Standard	Class
1		X101-000200	BAR,GUIDE 25	1	C25H25-60CLD ED	A
2		431610-10030	CHAIN, SAW 25AP-60E	1	25AP-60E	A
3		X490-000840	SCABBARD,CHAIN	1		D
4		X602-000160	PLUG WRENCH	1		D
5		X605-000190	TOOL,L WRENCH	1	T27 120*80	D

Class : Consumable class

A:Fast moving parts B:Semi-fast moving parts C:Slow moving parts D:Order only as needed

# OILER

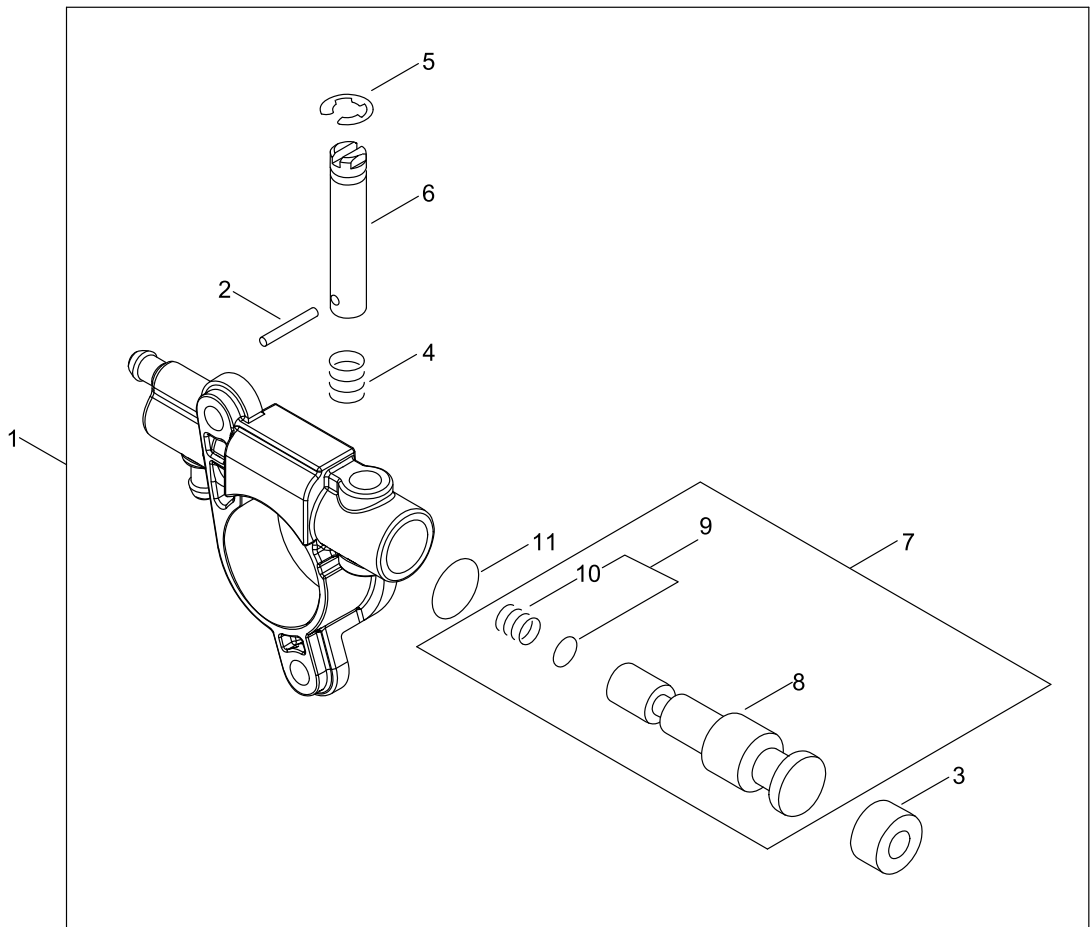





## OILER

Key No.	LV (+)	Parts Number	Parts Description	Qty	Standard	Class
1		C022-000211	AUTO-OILER ASSEMBLY	1	OP-27C(B)	C
2	+	P003-002180	PIN, SPRING	1		D
3	+	437062-38330	CAP, OIL PUMP	1		D
4	+	437015-37330	SPRING	1		D
5	+	123127-15030	RING	1		D
6	+	P003-005430	NEEDLE-ADJ	1		D
7	+	P200-000390	PLUNGER SHAFT KIT	1		D
8	++	P003-005990	SHAFT ASY-PLUNGER	1		D
9	++	P200-000490	SPRING WASHER KIT	1		D
10	+++	P003-006000	SPRING	1		D
11	+	P003-005420	WASHER	1		D

Class : Consumable class

A:Fast moving parts B:Semi-fast moving parts C:Slow moving parts D:Order only as needed

## GUIDE BAR, CHAIN

Pitch ピッチ  (inch) (mm)	Gauge ゲージ  (inch) (mm)	Length 長さ  (cm)	Guide Bar ガイドバー		Saw Chain ソーチェン		Hard Nose  ハード ノーズ  	Sprocket Nose  スプロケット ノーズ  
			Key №	Type 形式	Key №	Type 形式		
1/4 6.35	0.050 1.27	20	A1	C20H25-52CL- ED	A2	25AP-52E	●	
1/4 6.35	0.050 1.27	25	B1	C25H25-60CL- ET	B2	25AP-60E	●	
1/4 6.35	0.050 1.27	25	C1	C25H25-60CLD ED	C2	25AP-60E	●	
3/8 9.53	0.050 1.27	20	D1	C20S91-35SA- ET	D2	91PX-35E		●
3/8 9.53	0.050 1.27	25	E1	C25S91-40SL- ET	E2	91PX-40E		●
3/8 9.53	0.050 1.27	30	F1	C30S91-47ML- ET	F2	91PX-47E		●
1/4 6.35	0.043 1.09	25	G1	C25HA4-60CL- ED	G2	A4S-60E	●	
1/4 6.35	0.043 1.09	20	H1	C20HA4-52CL- ED	H2	A4S-52E	●	

## GUIDE BAR, CHAIN

Key No.	LV (+)	Parts Number	Parts Description	Qty	Standard	Class
A1		X100-000060	BAR,GUIDE 20	1	C20H25-52CL- ED	A
A2		X200-000000	CHAIN,SAW	1	25AP-52E	A
B1		X101-000011	BAR,GUIDE 25	1	C25H25-60CL- ET	A
B2		431610-10030	CHAIN, SAW 25AP-60E	1	25AP-60E	A
C1		X101-000200	BAR,GUIDE 25	1	C25H25-60CLD ED	A
C2		431610-10030	CHAIN, SAW 25AP-60E	1	25AP-60E	A
D1		X120-000021	BAR,GUIDE 20	1	C20S91-35SA- ET	A
D2		X220-000020	CHAIN,SAW	1	91PX-35E	A
E1		X121-000003	BAR,GUIDE 25	1	C25S91-40SL- ET	A
E2		X221-000100	CHAIN,SAW	1	91PX-40E	A
F1		X122-000073	BAR,GUIDE 30	1	C30S91-47ML- ET	A
F2		X222-000140	CHAIN,SAW	1	91PX-47E	A
G1		X101-000210	BAR,GUIDE 25	1	C25HA4-60CL- ED	A
G2		X201-000020	CHAIN,SAW	1	A4S-60E ECHO	A
H1		X100-000070	BAR,GUIDE 20	1	C20HA4-52CL- ED	A
H2		X200-000020	CHAIN,SAW	1	A4S-52E ECHO	A

Class : Consumable class

A:Fast moving parts B:Semi-fast moving parts C:Slow moving parts D:Order only as needed

# OPTION PARTS

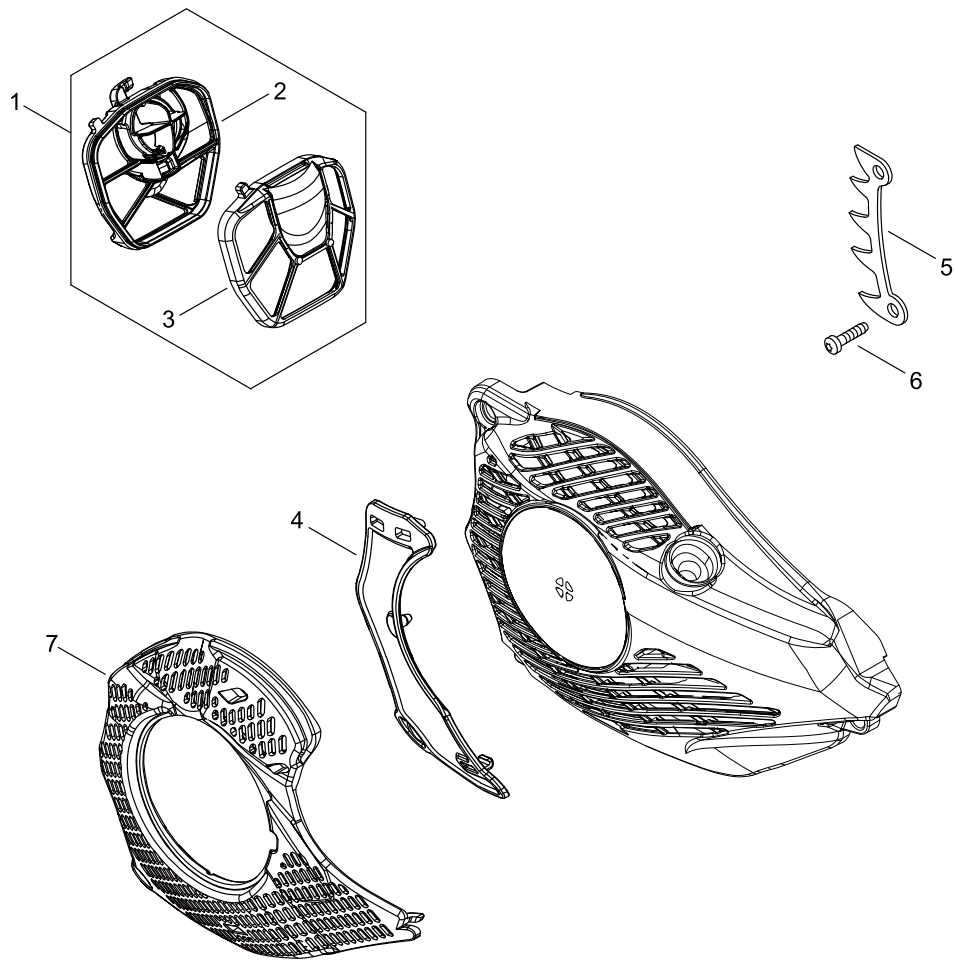

## OPTION PARTS

Key No.	LV (+)	Parts Number	Parts Description	Qty	Standard	Class
1		A226-001991	ELEMENT, AIR FILTER	1	NON-WOVEN	A
2	+	A226-001970	ELEMENT, AIR FILTER	1		A
3	+	A226-001981	ELEMENT, AIR FILTER	1		A
4		C418-000150	SHIELD, SNOW	1		C
5		C304-000000	SPIKE	1		C
6		V805-000240	BOLT, TORX 5	2	TT-5*12 DG 10.9	C
7		A127-000480	COVER,DUST	1		C

Class : Consumable class

A:Fast moving parts B:Semi-fast moving parts C:Slow moving parts D:Order only as needed

# NUMERICAL PARTS INDEX

Part No	Part description	Page	Part No	Part description	Page	Part No	Part description	Page
100014-55930	SPACER, PISTON PIN	2	A056-000800	CLUTCH ASY	18	C334-000340	CONNECTOR, BRAKE	18
100015-04630	CIRCLIP, PISTON PIN	2	A101-000700	RING, PISTON	2	C345-000640	COVER, BRAKE	18
100142-12330	KEY, WOODRUFF	6	A127-000450	COVER, DUST	4	C400-001550	HANDLE, FRONT	16
123110-03930	SCREW, PUMP COVER	10	A127-000480	COVER, DUST	26	C418-000150	SHIELD, SNOW	26
123112-15030	DIAPHRAGM, FUEL PUMP	10	A172-003200	COVER, FAN	14	C450-000950	CONTROL, THROTTLE	16
123113-37530	SPRING, THROTTLE RTN	10	A202-000290	BELLOWS, INTAKE	8	C454-000540	ROD, THROTTLE	16
123114-38830	SCREW	10	A204-000250	ELBOW, CARBURETOR	8	C460-000590	LOCKOUT, THROTTLE	16
123122-39830	SPRING, METER. LEVER	10	A219-000071	SHUTTER, AIR	4	C646-000132	RING, HARNESS	16
123123-03930	LEVER, METERING	10	A226-001970	ELEMENT, AIR FILTER	26	C649-000420	HOOK	18
123124-02960	COVER, FUEL PUMP	10	A226-001981	ELEMENT, AIR FILTER	26	C649-000440	HOOK	4
123125-15030	GASKET, FUEL PUMP	10	A226-001991	ELEMENT, AIR FILTER	26	P003-000380	THROTTLE, LEVER	10
123126-10631	SCREEN, INLET	10	A226-002120	ELEMENT, AIR FILTER	8	P003-000410	VALVE CHOKE	10
123127-15030	RING	10	A226-002130	ELEMENT, AIR FILTER	8	P003-001300	SHAFT, THROTTLE	10
123127-15030	RING	22	A226-002140	ELEMENT, AIR FILTER	8	P003-001510	LEVER-FAST IDLE	10
123130-02960	SCREW	10	A232-001842	LID, CLEANER	8	P003-001850	DIAPHRAGM, METERING	10
123133-04260	SPRING, IDLE ADJUST	10	A235-000410	KNOB, CLEANER LID	8	P003-002180	PIN, SPRING	22
123134-04260	SCREW, IDLE ADJUST	10	A239-000110	PIPE, INTAKE	4	P003-002380	SCREW	10
123137-19830	VALVE, INLET NEEDLE	10	A310-000490	SCREEN, ARRESTOR	12	P003-004190	NEEDLE	10
123138-03930	PIN, METERING LEVER	10	A312-000090	PLATE, EXHUST	12	P003-004780	SPRING	10
123139-03930	SCREW, M. LEVER PIN	10	A320-001210	COVER, MUFFLER	12	P003-005420	WASHER	22
123140-27230	GASKET, M. DIAPHRAGM	10	A365-000050	CONNECTOR, CAP	4	P003-005430	NEEDLE-ADJ	22
123142-03930	COVER, M. DIAPHRAGM	10	A369-000420	STRAINER, FUEL	4	P003-005750	VALVE, THROTTLE	10
123146-10631	PLUG, WELCH	10	A409-001300	ROTOR, MAGNETO	6	P003-005760	SHAFT-CHOKE	10
131300-56431	VENT ASSEMBLY, FUEL	4	A425-000060	SPARKPLUG	6	P003-005990	SHAFT ASY-PLUNGER	22
177236-61830	SCREW	14	A426-000010	TERMINAL, SPARKPLUG	6	P003-006000	SPRING	22
431610-10030	CHAIN, SAW 25AP-60E	20	A427-000190	CAP, SPARK PLUG	6	P003-006290	SCREW, IDLE ADJUST	10
431610-10030	CHAIN, SAW 25AP-60E	24	A429-000200	COVER, CAP	4	P021-050120	PISTON KIT	2
436114-13930	VALVE, CHECK	4	A440-002741	SWITCH, ON OFF	16	P021-050130	CRANKCASE SET	2
437015-37330	SPRING	22	A514-000300	PAWL	6	P021-050140	STRAINER, OIL ASY	2
437062-38330	CAP, OIL PUMP	22	A551-000170	PLATE, CLUTCH	18	P021-050160	COIL, IGNITION	6
900216-04006	SCREW	12	A552-000430	HUB, CLUTCH	18	P021-050190	CLUTCH SHOE SET	18
900800-36001	BEARING, BALL	2	A556-001710	DRUM, CLUTCH	18	P021-050202	GUARD, SPROCKET ASY	18
93050-30080	ROLLER	18	A566-000290	SPRING, CLUTCH	18	P021-051910	ENGINE COVER ASY	4
A011-001440	CRANKSHAFT, ASM	2	C022-000211	AUTO-OILER ASSEMBLY	2	P021-051920	CYLINDER	2
A021-004520	CARBURETOR, DIAPHRAGM	8	C022-000211	AUTO-OILER ASSEMBLY	22	P022-036670	SPRING, DAMPER	14
A021-004520	CARBURETOR, DIAPHRAGM	10	C236-000150	COVER, OILER	2	P022-040050	DRUM	14
A021-005160	CARBURETOR, DIAPHRAGM	8	C300-001112	GUARD, SPROCKET	18	P022-040060	SPRING KIT, REWIND	14
A021-005160	CARBURETOR, DIAPHRAGM	10	C304-000000	SPIKE	26	P022-040070	SPRING CASE	14
A030-000860	MUFFLER ASY	12	C305-000490	PLATE, SPROCKET GUARD	4	P022-040080	PLATE, CAM	14
A033-000390	OIL, CAP	4	C305-000500	PLATE, SPROCKET GUARD	18	P022-040090	ROPE, STARTER	14
A033-000410	CAP, FUEL	4	C309-000110	TENSIONER, CHAIN	18	P022-040100	GRIP, STARTER	14
A035-000040	PUMP, FUEL	4	C310-000140	CATCHER, CHAIN	4	P022-045300	CASE, STARTER ASY	14
A051-003131	STARTER, RECOIL ASY	14	C320-000510	LEVER, BRAKE	18	P100-002151	HANDLE SET, REAR	16
			C328-000330	BAND, BRAKE	18	P100-006570	COIL, IGNITION	6
						P200-000390	PLUNGER SHAFT KIT	22

# NUMERICAL PARTS INDEX

Part No	Part description	Page	Part No	Part description	Page	Part No	Part description	Page
P200-000490	SPRING WASHER KIT	22	V505-000070	OIL SEAL	2	X605-000190	TOOL,L WRENCH	20
V100-000830	GASKET,CYL	2	V553-000020	BEARING,NEEDLE 8	2			
V102-000290	GASKET,CRANKCASE	2	V555-000190	BEARING,NEEDLE 10	18			
V104-002290	GASKET,EXHAUST	12	V606-000020	PIN,ENG 8	2			
V107-000180	GASKET,FUEL CAP	4	V651-000011	GEAR,BEVEL	18			
V131-000220	GROMMET,NEEDLE	16	V651-001060	GEAR,BEVEL	18			
V137-000140	GROMMET,FUEL	4	V652-000230	GEAR,WORM	2			
V162-000760	PLUG	16	V804-000000	BOLT, TORX 4	4			
V162-000770	PLUG	8	V804-000000	BOLT, TORX 4	18			
V186-000020	JOINT,PIPE	4	V804-000010	BOLT, TORX 4	4			
V186-000510	JOINT,PIPE	4	V804-000010	BOLT, TORX 4	12			
V186-000530	JOINT,PIPE	4	V804-000010	BOLT, TORX 4	16			
V203-000041	BOLT,5	18	V804-000040	BOLT, TORX 4	8			
V203-002250	BOLT,5	6	V804-000050	BOLT, TORX 4	2			
V203-002260	BOLT,5	4	V804-000060	BOLT, TORX 4	6			
V203-002270	BOLT,5	18	V804-000060	BOLT, TORX 4	14			
V203-002280	BOLT,5	4	V804-000100	BOLT, TORX 4	2			
V225-000262	BOLT,STUD 8	4	V804-000100	BOLT, TORX 4	4			
V265-000140	NUT	6	V805-000000	BOLT, TORX 5	16			
V265-000550	NUT,8	18	V805-000070	BOLT, TORX 5	8			
V308-000030	WASHER,CIRCULAR 11	2	V805-000150	BOLT, TORX 5	12			
V341-000200	WASHER,SQUARE	4	V805-000240	BOLT, TORX 5	26			
V351-000030	COLLAR,3	8	X100-000060	BAR,GUIDE 20	24			
V352-000300	COLLAR,4	6	X100-000070	BAR,GUIDE 20	24			
V355-000840	COLLAR,8	18	X101-000011	BAR,GUIDE 25	24			
V355-000860	COLLAR,8	18	X101-000200	BAR,GUIDE 25	20			
V356-000780	COLLAR,10	18	X101-000200	BAR,GUIDE 25	24			
V358-000220	COLLAR,14	8	X101-000210	BAR,GUIDE 25	24			
V376-000450	SPACER	18	X120-000021	BAR,GUIDE 20	24			
V450-002050	SPRING,COMPRESSION	4	X121-000003	BAR,GUIDE 25	24			
V450-002060	SPRING,COMPRESSION	4	X122-000073	BAR,GUIDE 30	24			
V450-002070	SPRING,COMPRESSION	4	X200-000000	CHAIN,SAW	24			
V450-002080	SPRING,COMPRESSION	18	X200-000020	CHAIN,SAW	24			
V452-000030	SPRING,TORSION	6	X201-000020	CHAIN,SAW	24			
V452-001650	SPRING,TORSION	16	X220-000020	CHAIN,SAW	24			
V452-001660	SPRING,TORSION	18	X221-000100	CHAIN,SAW	24			
V470-002171	PIPE	2	X222-000140	CHAIN,SAW	24			
V470-002180	PIPE	4	X490-000840	SCABBARD,CHAIN	20			
V470-002190	PIPE	4	X502-000340	LABEL,ECHO	18			
V470-002200	PIPE	2	X502-001030	LABEL,ECHO	14			
V470-002210	PIPE	4	X502-001110	LABEL,ECHO	14			
V471-003660	PIPE	4	X503-014140	LABEL,MODEL	8			
V471-003820	PIPE	4	X505-007710	LABEL,CAUTION	12			
V471-004870	PIPE	4	X505-008600	LABEL,CAUTION	4			
V490-000500	CLIP	4	X602-000160	PLUG WRENCH	20			