

Parts Manual for

SNAPPER®

17.5 & 18 HP 38" REAR DISCHARGE EUROPEAN TRACTOR RD SERIES

<i>Model No.</i>	<i>Description</i>
1696111-00	ELT17538RDF
1696112-00	ELT1838RDF

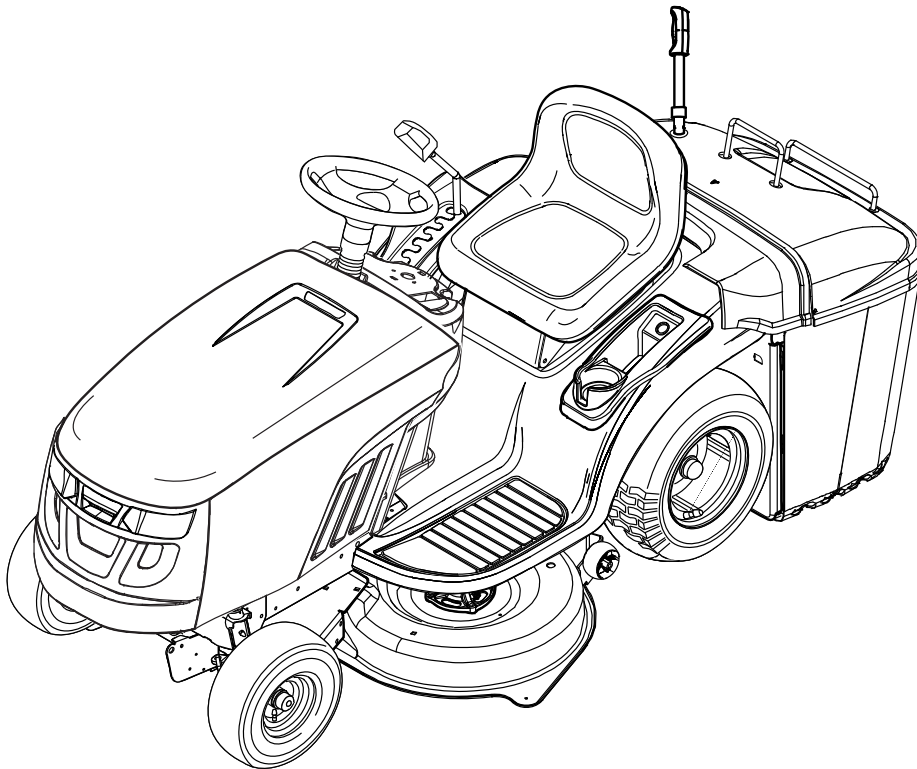

Briggs & Stratton Yard Power Products Group

535 Macon Road
McDonough, GA, 30253 U.S.A.
800-935-2967

Manual No. 7105570
Revision: A 3/6/2012

Not for
Reproduction

PAGE	GROUP
4	Wheel & Tire Group
6	Hood, Grille & Dash Group
8	Seat Deck & Fuel Tank
10	Steering Group
12	Frame & Front Axle Group
16	Controls Group
18	Engine Group - 17.5HP & 18HP
20	Transmission Group
22	Transmission SERVICE PARTS - Hydro Gear 324-0610
28	Lift Group
30	38" Mower Deck - Housing, Arbors & Blade
32	38" Mower Deck - Clutch Group
34	38" Mower Deck - Support Group
36	Guard Group - 38" RD
38	Collector Group
42	Decal Group
44	Electrical Group

Not for
Reproduction

Wheel & Tire Group

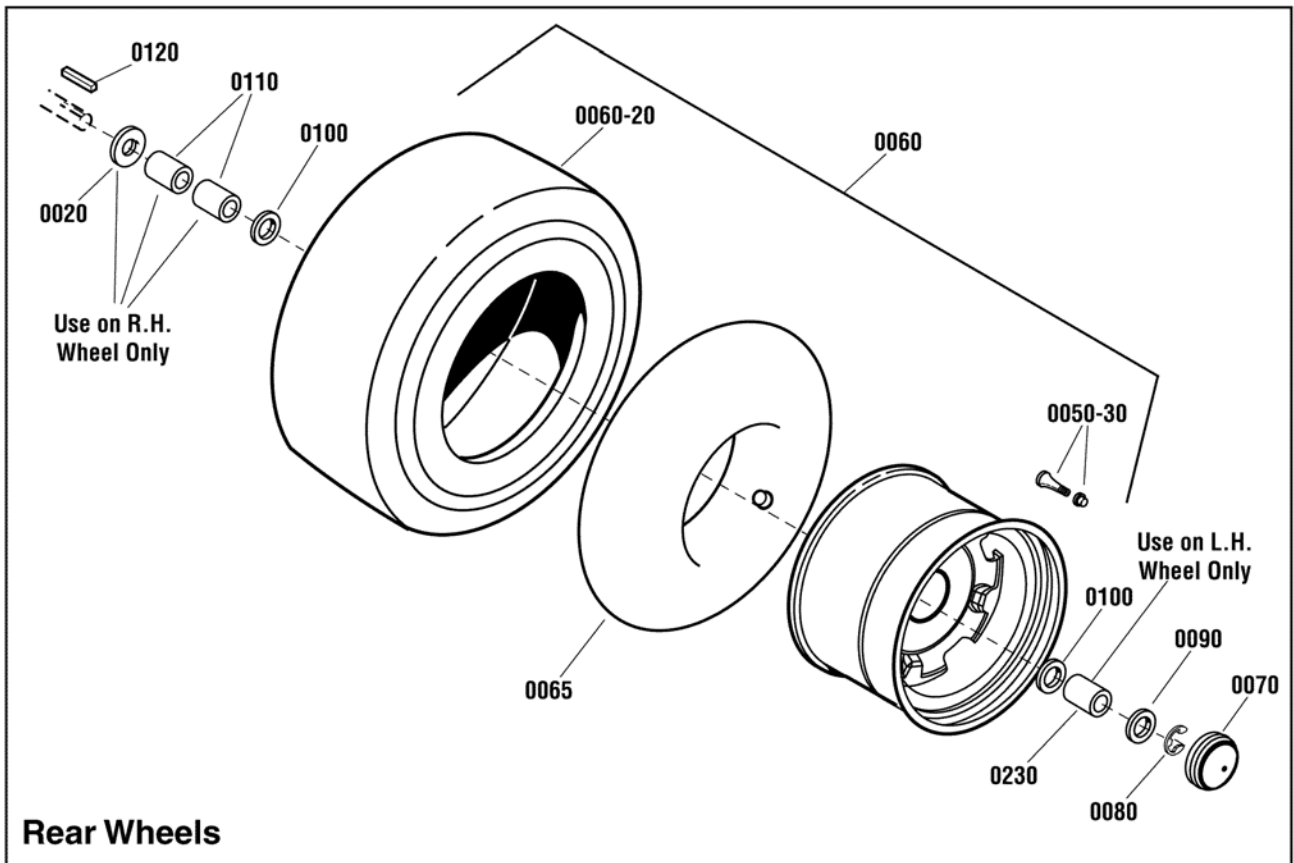
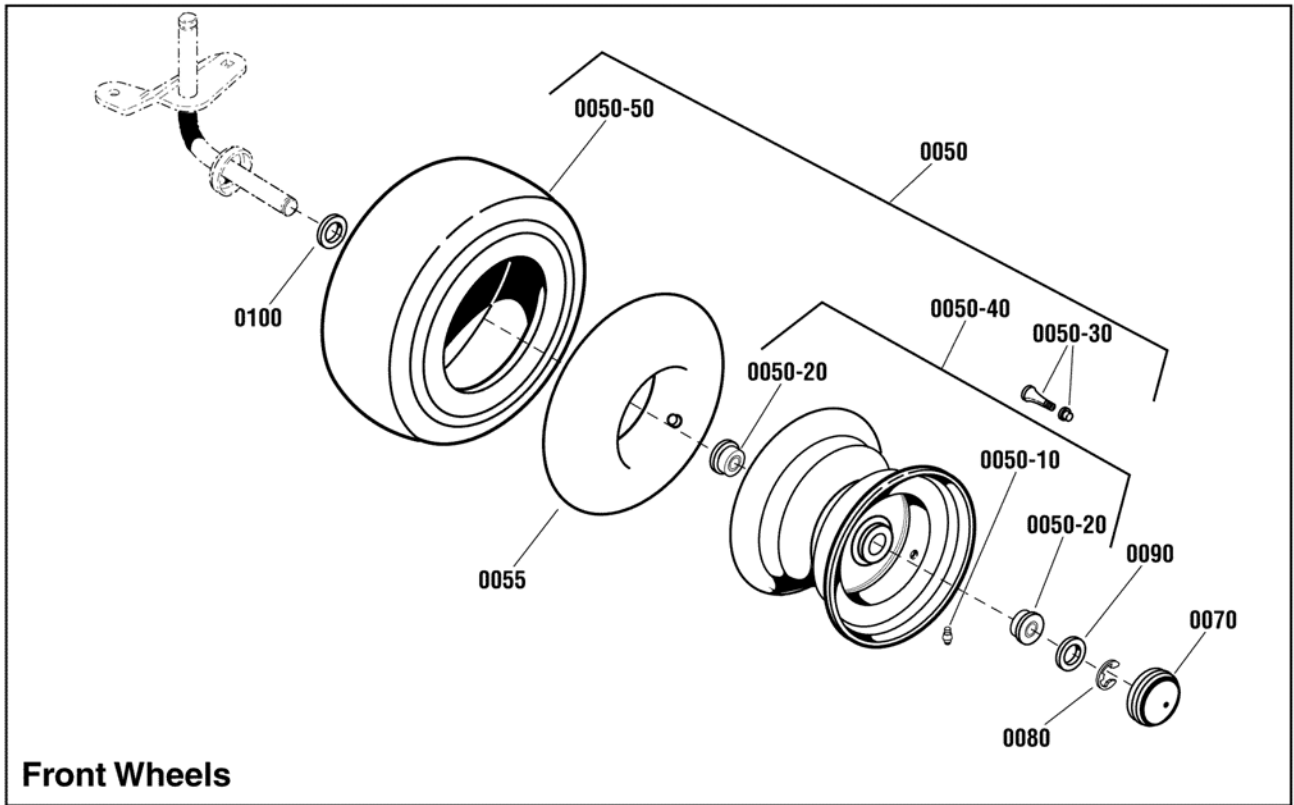

Item	Part No	Qty	Description
0020	2860202	1	WASHER, 3/4
0050	1729708	2	WHEEL& TIRE ASSEMBLY, Front (Includes Ref. Nos. 0050-10, 0050-20, 0050-30, 0050-40 & 0050-50)
0050-10	2812808	1	FITTING, Lube
0050-20	1713167	2	BEARING, 3/4
0050-30	2172353	4	VALVE STEM & CAP
0050-40	1726301	1	WHEEL & BUSHINGS ASSEMBLY, Front (Includes Ref. Nos. 0050-10 & 0050-30)
0050-50	1731951	1	TIRE, Kenda, Turf Rider, Front, 15 x 6.00 - 6
0055	1664090	2	TUBE, Tire, Front
0060	885457	2	WHEEL & TIRE ASSEMBLY, Rear, 20 X 8-8 (Includes Ref. Nos. 0050-30 & 0060-20)
0060-20	-----	1	TIRE, Rear, K358 x 20 x 8.94-8 (Not a serviceable part, order Ref. 0060)
0065	2164247	2	TUBE, Tire, Rear
0070	721318	4	HUB CAP
0080	720010	4	E-RING
0090	722620	4	WASHER, Flat
0100	722598	4	WASHER, Flat, 3/4 x 1-1/4
0110	1730181	2	SPACER, 3/4 ID x 1-1/4 OD x 1-5/8, RH (Use on R.H. Side Only)
0120	720258	2	KEY, Square, 3/16
0230	885578	1	SPACER, Wheel, LH (Use on L.H. Side Only)

Not for
Reproduction

Footnotes:

Hood, Grille & Dash Group

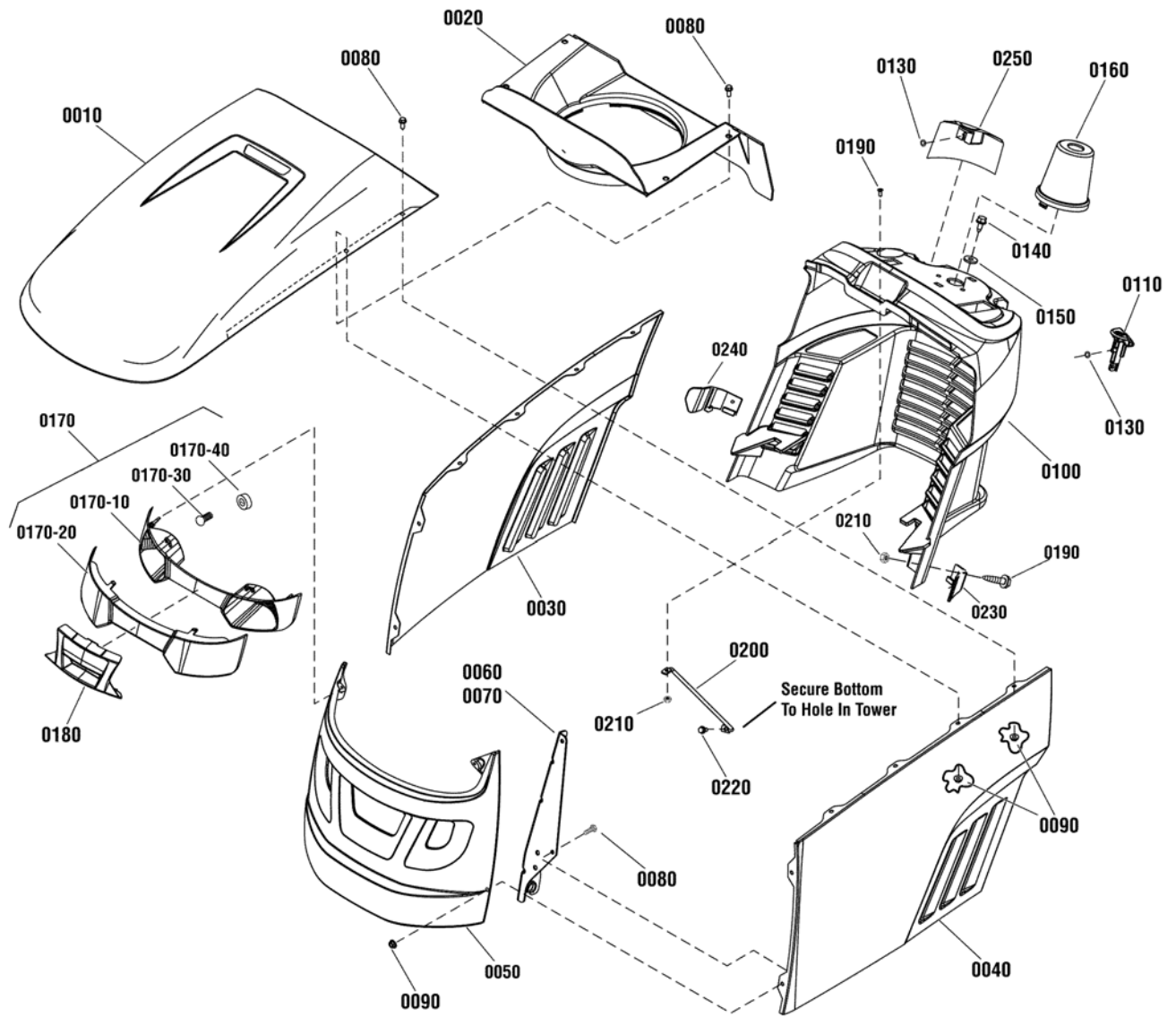

Item	Part No	Qty	Description
0010	1728031D	1	HOOD, With Scoop
0020	7102326	1	AIR DUCT, Plenum
0030	1727294D	1	PANEL, Side, R.H.
0040	1727295D	1	PANEL, Side, L.H.
0050	1728059D	1	GRILLE
0060	1727279A	1	HINGE, Hood, L.H.
0070	1727280A	1	HINGE, Hood, R.H.
0080	1960295	12	CAPSCREW, Hex Flange Whiz Lock, 1/4-20 x 5/8
0090	1930641	12	NUT, Hex Flange Whiz Lock Large, 1/4-20
0100	885583	1	CONSOLE
0110	1728089	1	KNOB, Brake Lock, Red
0130	1960518	2	PUSHNUT, 1/4
0140	1664847	2	CAPSCREW, Hex Washer Head, Taptite, 5/16-18 x 3/4
0150	1919381	2	WASHER, 5/16
0160	1727999	1	COVER
0170	1727296	1	HEADLIGHT ASSEMBLY (Includes Ref. Nos. 0170-10, 0170-20, 0170-30 & 0170-40)
0170-10	1728973	1	REFLECTOR
0170-20	1728974	1	LENS, Headlight
0170-30	1677371	2	BULB, Headlight, 1141-12V 21CP
0170-40	1723451	2	SOCKET
0180	1728975	1	INSERT, Lightbar
0190	1960392	3	SCREW, Pan Head Phillips, #10-24 x 1/2
0200	885435BM	1	ROD, Bagger Support
0210	1933896	3	NUT, Nylock, 10-24
0220	1925003	1	CAPSCREW, Hex Washer Head, Taptite, 1/4-20 x 1/2
0230	1732030	1	GUIDE, Hood, L.H.
0240	1732031	1	GUIDE, Hood, R.H.
0250	885686	1	PLUG, Cruise Control

Footnotes:

Seat Deck & Fuel Tank

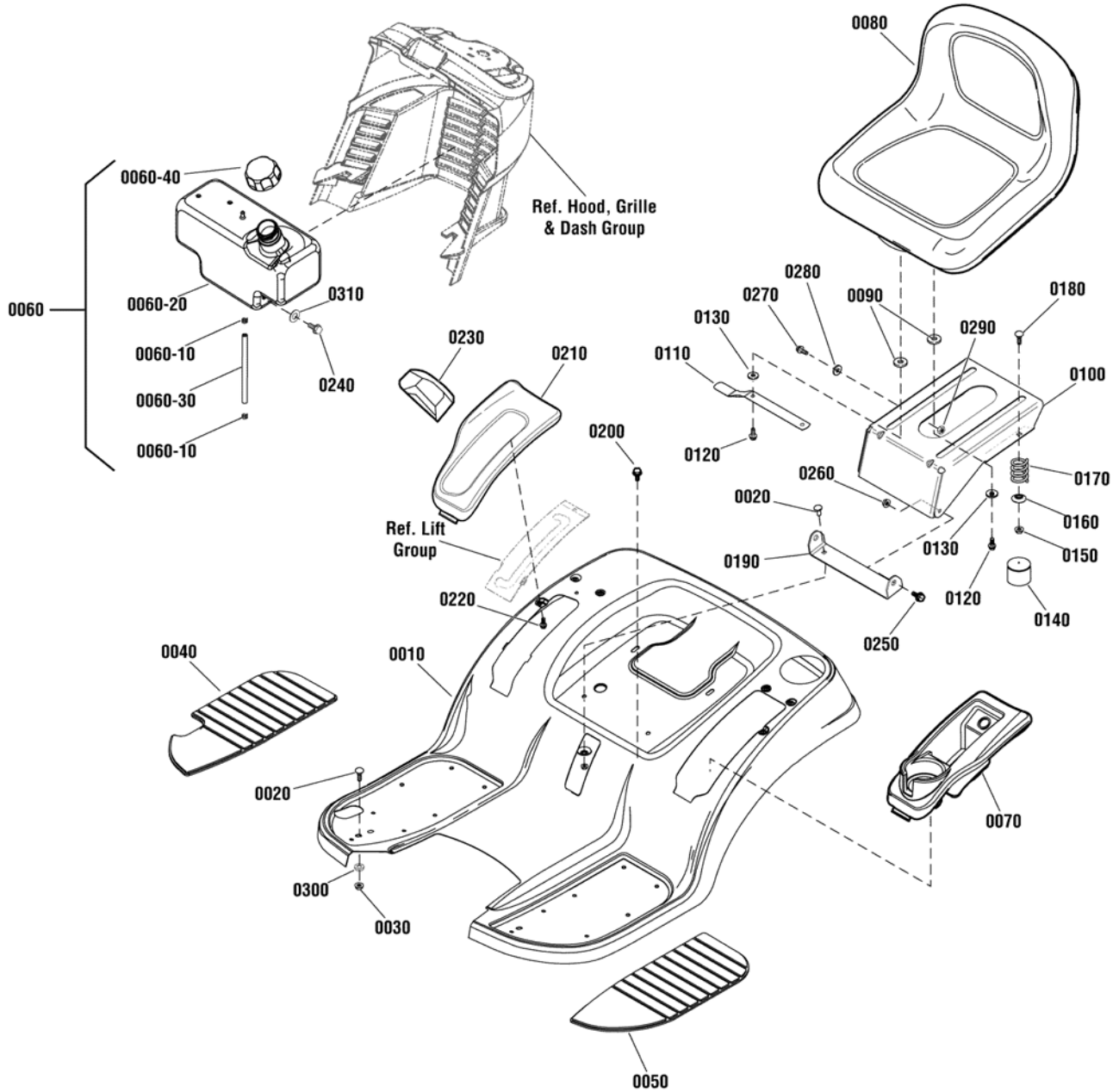

Item	Part No	Qty	Description
0010	885687D	1	DECK, Seat
0020	1931333	4	BOLT, Carriage, 5/16-18 x 3/4 G5
0030	1931277	4	NUT, Hex Flange Whiz Lock Small, 5/16-18
0040	1728007	1	PAD, Footrest, R.H.
0050	1728006	1	PAD, Footrest, L.H.
0060	885548	1	FUEL TANK ASSEMBLY (Includes Ref. Nos. 0060-10, 0060-20, 0060-30 & 0060-40)
0060-10	721403	2	CLAMP, Hose
0060-20	-----	1	TANK, Fuel (Not a serviceable part, order Ref. 0060)
0060-30	7200118	1	HOSE, Fuel
0060-40	727333	1	CAP, Gas
0070	1739535	1	POD, L.H.
0080	1730158	1	SEAT, Lo Back
0090	1731300	4	SPACER, 5/16 ID x 1-1/4 OD x 5/16
0100	1727265A	1	SUPPORT, Seat
0110	1727268A	1	LATCH, Seat
0120	1960667	4	CAPSCREW, Hex Flange Whiz Lock, 5/16-18 x 1
0130	1919381	4	WASHER, 5/16
0140	1704724	2	COVER, Spring
0150	1960686	2	NUT, Hex Flange, ESNA, 5/16-18
0160	1709256	4	WASHER, Spring
0170	1704728	2	SPRING, Compression
0180	1960282	2	BOLT, Carriage, 5/16-18 x 3/4 G5
0190	885538A	1	PIVOT, Seat
0200	1930601	2	CAPSCREW, Hex Washer Head, Taptite, 5/16-18 x 5/8
0210	1739537	1	POD, R.H.
0220	1960536	6	SCREW, Hex Washer Head, Plastite, 1/4 x 1/2
0230	1722302	1	GRIP
0240	1921958	2	CAPSCREW, Hex Head, 1/4-20 x 1/2, G5
0250	1729576	2	BOLT, Shoulder, 5/16-18
0260	1960686	2	NUT, Hex Flange, ESNA, 5/16-18
0270	1923114	1	CAPSCREW, Hex Head, 1/2-13 x 1, G5
0280	1960170	1	WASHER, 1/2
0290	5025038	1	NUT, Hex, 1/2-13
0300	885382	2	WASHER, Rubber
0310	1960353	2	WASHER, 1/4

Footnotes:

Steering Group

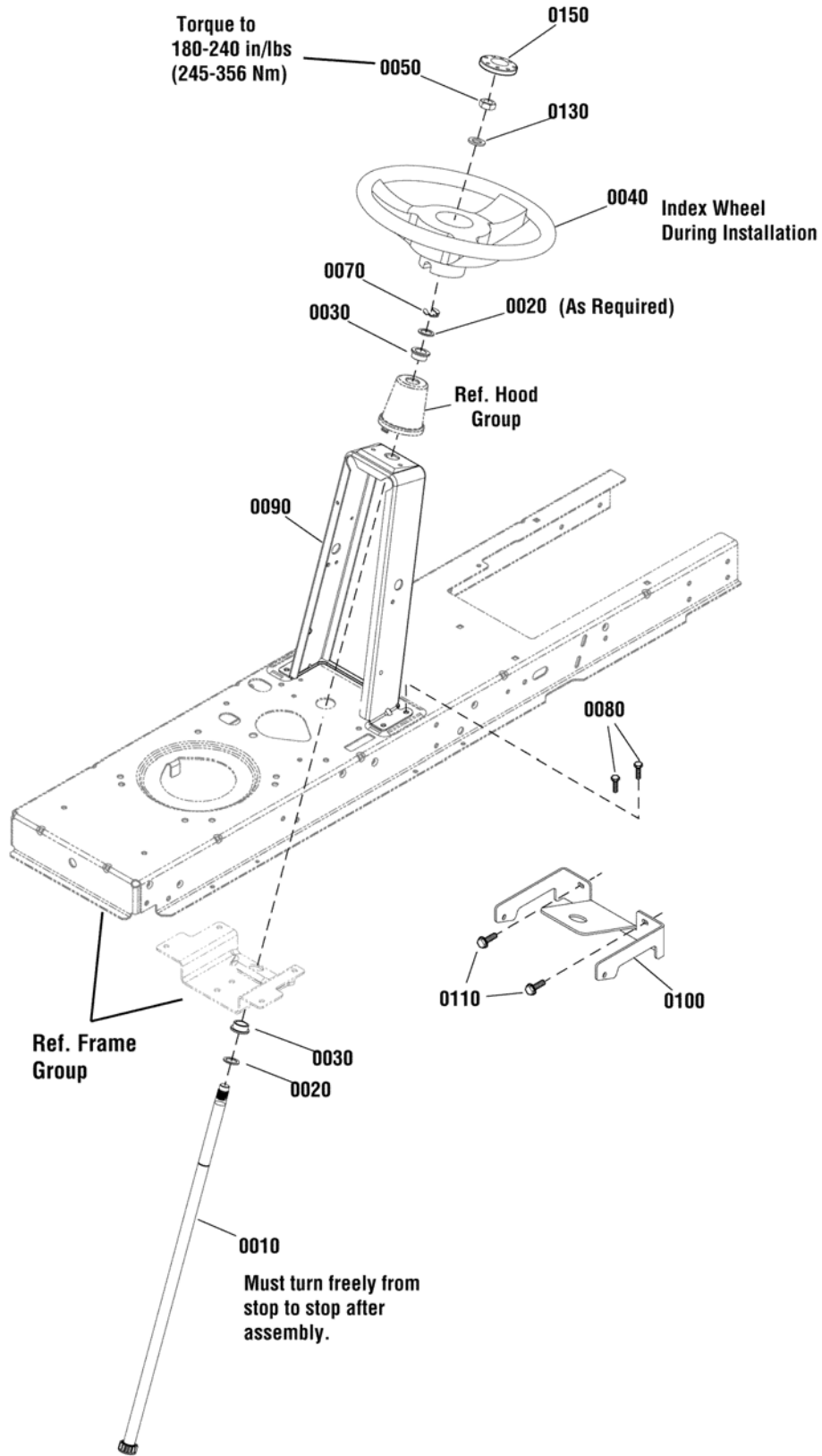

Item	Part No	Qty	Description
0010	1727813	1	SHAFT, Steering Gear & Spline Yellow
0020	1960114	2	WASHER, 3/4 x 1
0030	1729665	2	BUSHING, Steering
0040	1728069	1	STEERING WHEEL
0050	1960576	1	NUT, Hex Lock, ESNA Light, 5/8-18, Thin
0070	1611710	1	RING, Klipring Extension
0080	1930601	4	SCREW, Hex Washer Head, Taptite
0090	885530A	1	TOWER
0100	7300653BM	1	BRACKET, Tank
0110	1925003	2	CAPSCREW, Hex Head, Taptite, 1/4-20 x 1/2
0130	1924366	1	WASHER, 5/8 x 1-1/8
0150	1725024	1	CAP, Steering Wheel, Plain

Not for
Reproduction

Footnotes:

Item	Part No	Qty	Description
0010	721318	2	CAP, Hub
0020	720010	2	E-RING, 3/4
0030	722620	4	WASHER, Flat
0040	885693	1	AXLE, Front
0050	2176440	4	BUSHING
0060	1738193	1	SPACER
0070	1727902	1	PLATE, Axle Support
0080	2860646	1	NUT, Hex Flange Two-Way Lock, 5/8-11
0090	1931277	16	NUT, Hex Flange, Whiz Lock, 5/16-18
0100	1960032	2	CAPSCREW, Hex Head, 3/8-16 x 1-1/4, .141 Thread G5
0110	1611705	2	SPACER
0120	1751964	1	ROD, Tie
0130	1727872A	1	SPINDLE & CUP ASSEMBLY, R.H.
0140	1930645	2	NUT, Hex, Flange, Locking, 3/8-16
0150	1751922	1	SPINDLE & ARM ASSEMBLY, L.H.
0160	885656BM	1	FRAME
0170	1727904	1	SUPPORT, Front Footrest R.H.
0180	1930601	8	SCREW, Taptite, 5/16-18 x 5/8
0190	1930591	6	CAPSCREW, Hex Head, Flange Whiz Lock, 5/16-18 x 3/4
0200	885536A	1	SUPPORT, Front Footrest L.H.
0210	1960035	1	WASHER, Flat, 5/8
0220	2860744	1	CAPSCREW, Hex Head, 5/8-11 x 3-1/4 G5
0230	1738051	1	LINK, Drag
0240	885694	1	PEDAL ASSEMBLY, Brake
0250	1735595	1	LATCH, Brake Lock
0260	1729576	1	BOLT, Shoulder, 5/16-18 x 1-1/8
0270	1727935	1	SPACER, Pivot
0280	1736714A	1	PEDAL ASSEMBLY, Forward
0290	1727246	1	PEDAL, Reverse
0300	1960223	2	BOLT, Carriage, 5/16-18 x 1-1/4
0310	1728024	1	SPACER, Foot Pedal
0320	1728025	1	ACTUATOR, RMO Switch
0330	885591A	1	BRACKET, Pedal Pivot
0340	1727911A	1	PLATE, Bearing
0350	885579A	1	LIFT SHAFT ASSEMBLY
0360	1727940	1	BRACKET, Sector Support
0370	1751110	1	GEAR, Steering
0380	1728122	2	SPACER, Sector Gear
0390	1960032	2	SCREW, Hex Head, 3/8-16 x 1-1/4, G5
0400	1930645	2	NUT, Hex Flange, Two Way Lock, 3/8-16
0420	885508A	1	BRACKET, Rear Frame, RH
0430	885509A	1	BRACKET, Rear Frame, LH
0440	885532A	1	BRACE, Middle Cross
0450	1931333	5	BOLT, Carriage, Short Neck, 5/16-18 x 3/4, G5

Footnotes:

Frame & Front Axle Group

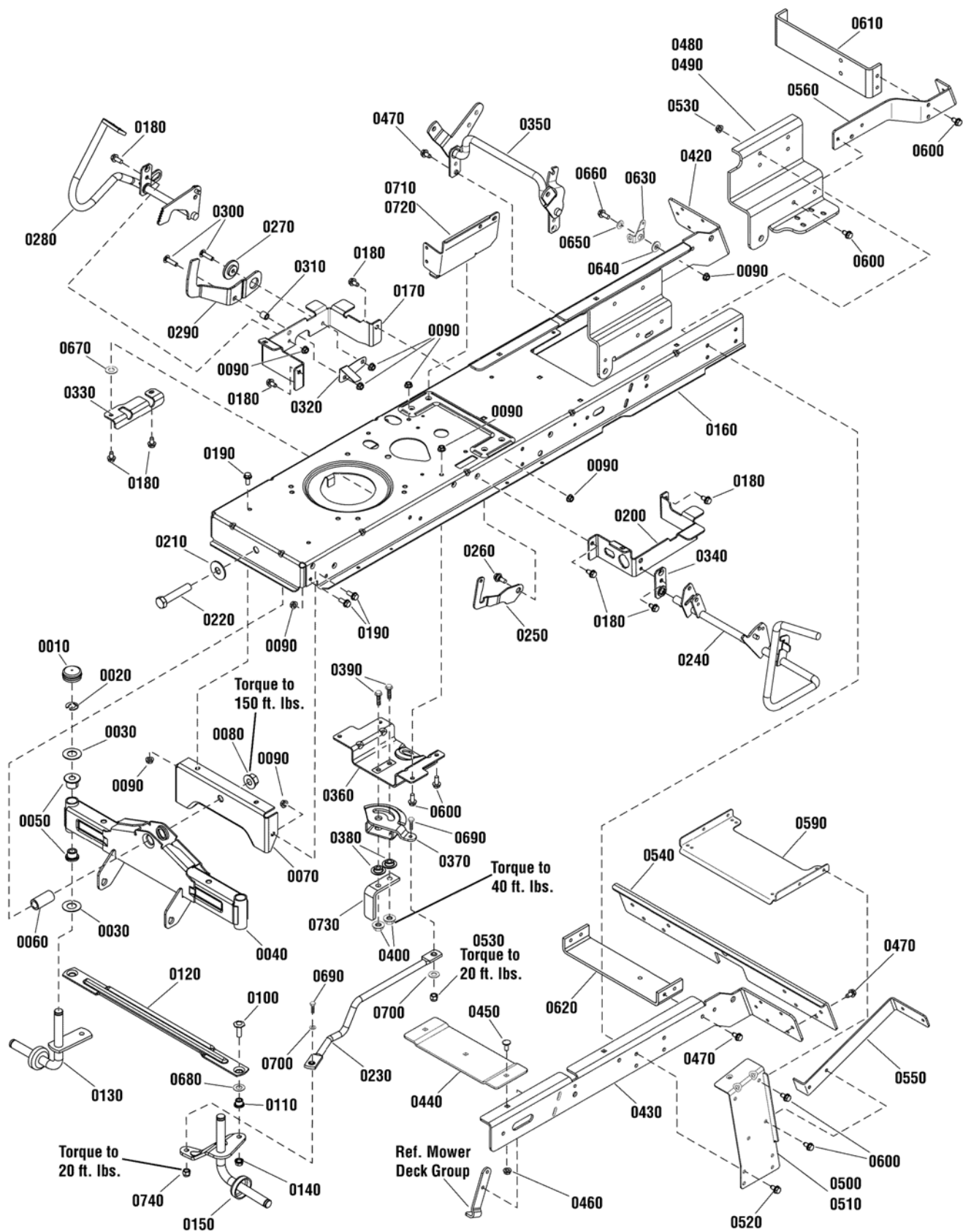

Item	Part No	Qty	Description
0460	1931277	5	NUT, Hex Flange, Whiz Lock, 5/16-18
0470	1664847	10	CAPSCREW, Hex Washer Head, Taptite, 5/16-18 x 3/4
0480	885474A	1	BRACKET, Transaxle, RH
0490	885475A	1	BRACKET, Transaxle, LH
0500	885411A	1	SUPPORT, Deck, R.H.
0510	885412A	1	SUPPORT, Deck, L.H.
0520	1921333	8	CAPSCREW, Hex Head, 5/16-18 x 1, G5
0530	1931277	8	NUT, Hex Flange, Whiz Lock, 5/16-18
0540	885469A	1	BRACKET, Middle Back Plate
0550	885466A	2	SUPPORT, Upper, Back Plate
0560	885467A	2	SUPPORT, Lower, Back Plate
0590	885503A	1	BRACE, Cross Deck Support
0600	1664847	23	CAPSCREW, Hex Washer Head, Taptite, 5/16-18 x 3/4
0610	885441A	1	BRACKET, Torque
0620	885486A	1	BRACKET, Idler Mount
0630	1728990A	1	CLEVIS, Lift
0640	1727935	1	SPACER, Pivot
0650	1960044	1	WASHER, 5/16
0660	1921333	1	CAPSCREW, Hex Head, 5/16-18 x 1, G5
0670	1919326	2	WASHER, 5/16
0680	1960703	2	WASHER, 5/8
0690	1921977	2	CAPSCREW, Hex Head, 5/16-18 x 1-1/4, G5
0700	1924874	2	WASHER, 5/16
0710	885695BM	1	BRACKET, Tower Support, LH
0720	885696BM	1	BRACKET, Tower Support, RH
0730	885791	1	UPSTOP
0740	1935048	2	NUT, Hex Flange, Two Way Lock, 5/16-18

Footnotes:

Item	Part No	Qty	Description
0050	1931277	2	NUT, Hex, Flange Whizlock, 5/16-18
0060	1727261	1	PEDAL, Brake Rubber
0070	1960687	2	NUT, Hex Flange, ESNA, 3/8-16
0080	885410A	1	BRACKET, Idler Front Movable
0090	885645	1	PULLEY, 3 OD Plastic
0100	1931352	1	BOLT, Carriage, 3/8-16 x 1-1/2
0110	1721675	1	PAD, Foot Pedal Forward
0120	1727259	1	PAD, Foot Pedal Reverse
0130	1727267	1	ROD, Parking Brake, 16-3/8"
0150	1728111	1	CLIP, Linkage, Black
0190	885484	1	BELT, Primary, M/D
0200	885565	1	IDLER, Backside
0210	1921971	1	CAPSCREW, Hex Head, 3/8-16 x 1-3/4, G5
0220	885534	2	BELT GUIDE
0230	885421	1	SPRING, Extension
0240	885426	1	PULLEY, Secondary Stack
0250	885577	1	BOLT, Carriage, 3/8-16 x 5
0260	1729620	1	SPRING, Extension 7-1/2"
0270	885683	1	ROD, Clutch
0280	7091809	1	PIN, Cotter
0290	727774	1	NUT, Adjusting
0300	1960103	2	WASHER, 3/8
0310	885684BM	1	BRACKET, Stack Pulley, Left
0320	1664847	4	SCREW, Hex Washer Head, Taptite, 5/16-18 x 3/4
0330	885575	2	SPACER
0340	1931942	1	NUT, Push Pal, 3/8
0350	1721995	1	SPRING, Extension
0360	885685BM	1	BRACKET, Stack Pulley, Right
0370	1918447	1	PIN, Cotter
0380	720142	1	NUT, Hex Flange, Centerlock, 3/8-16

Footnotes:

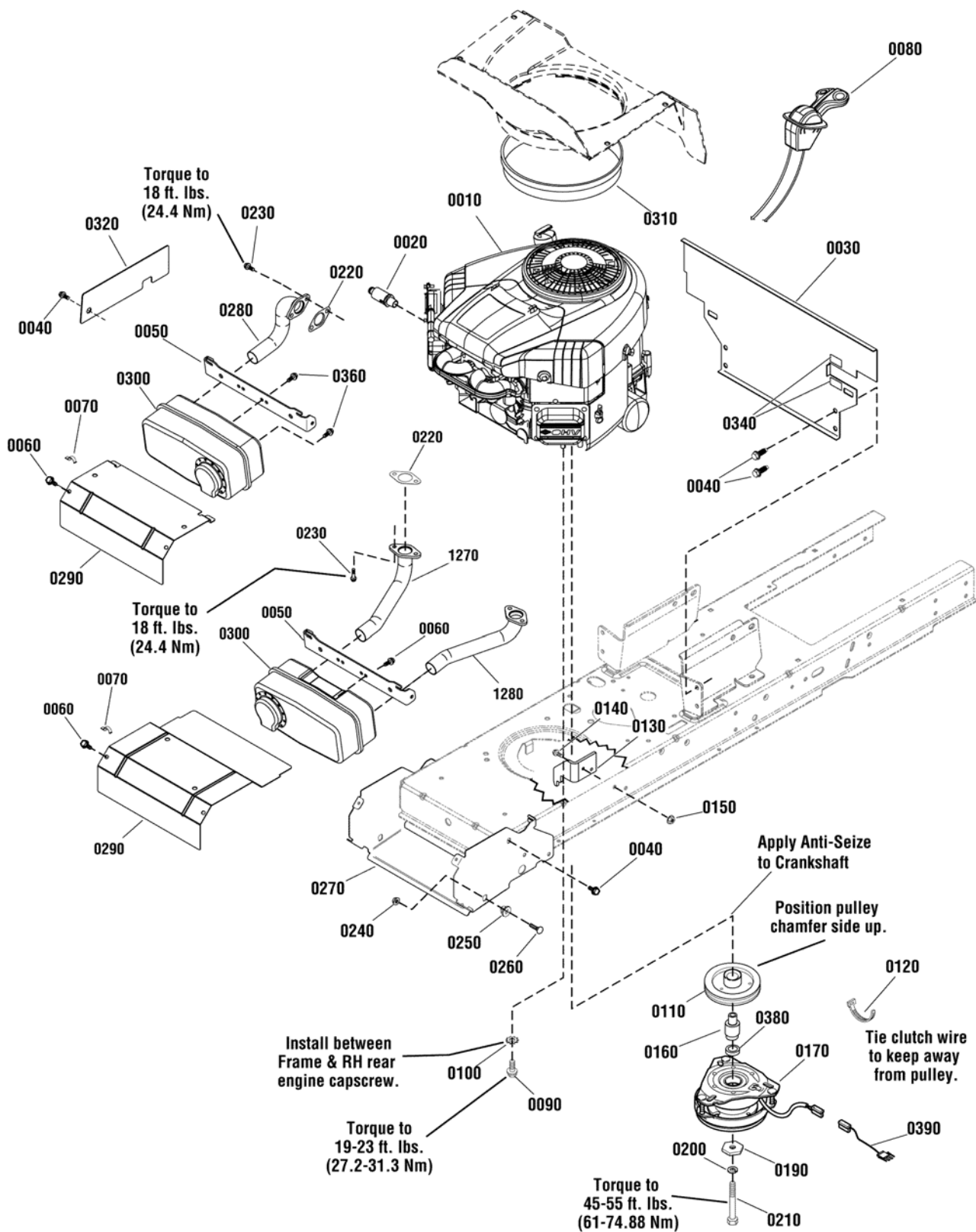

Item	Part No	Qty	Description
0010	31G777-0194-B1	1	* ENGINE, 17.5HP Briggs & Stratton, Model 31G777-0194-B1
0010	31G777-0204-B1	1	* ENGINE, 17.5HP Briggs & Stratton, Model 31G777-0204-B1
0010	405577-0116-B1	1	* ENGINE, 18HP Briggs & Stratton, Model 405577-0116-B1
0020	1750159	1	VALVE, Shut Off Oil Drain
0030	885677A	1	HEAT SHIELD
0040	1930601	10	SCREW, Hex Washer Head, Taptite, 5/16-18 x 5/8
0050	1727976A	1	SUPPORT, Muffler
0060	1925003	2	SCREW, Hex Washer Head, Taptite, 1/4-20 x 1/2 (Qty 4 used on 18HP Models)
0070	2834683	1	WIRE CLIP
0080	1751734	1	THROTTLE CONTROL, Choke-A-Matic (Used on 17.5HP Models)
0080	1727817	1	THROTTLE CONTROL, Double (Used on 18HP Models)
0090	2827187	4	SCREW, Hex Washer, Taptit, 3/8-16 x 1
0100	2820427	1	LOCKWASHER, External Tooth
0110	1732576	1	PULLEY & HUB ASSEMBLY, Engine
0120	1701011	2	TIE, Self Locking
0130	885535A	1	BRACKET, Electric Clutch Torque
0140	1921332	2	CAPSCREW, Hex Head, 5/16-18 x 3/4, G5
0150	1931277	2	NUT, Hex Flange, Whiz Lock, 5/16-18
0160	885679	1	SPACER, Electric Clutch
0170	885680	1	CLUTCH, Electric
0190	1708264	1	WASHER, 7/16
0200	1918199	1	LOCKWSHER, Spring
0210	7102075	1	CAPSCREW, Hex Head, 7/16-20 x 5
0220	1731214	1	GASKET, Exhaust (Qty 2 used on 18HP Models)
0230	94480	2	** SCREW, Hex SEMS Lock Washer 5/16-18 x 7/8 (Qty 4 used on 18HP Models)
0240	1931277	2	NUT, Hex Flange, Whiz Lock, 5/16-18
0250	1728086	2	PIVOT, Hood
0260	1931335	2	BOLT, Carriage, 5/16-18 x 1
0270	1727982A	1	BRACKET, Muffler
0280	1728959	1	EXHAUST PIPE, Single (Used on 17.5HP Models)
0290	1727996A	1	HEAT SHIELD, Single (Used on 17.5HP Models)
0290	1727997A	1	HEAT SHIELD, Twin (Used on 18HP Models)
0300	885615	1	MUFFLER, Single (Used on 17.5HP Models)
0300	1727994	1	MUFFLER, Twin (Used on 18HP Models)
0310	1734166	1	EDGING, Rubber, Single (Used on 17.5HP Models)
0310	1731970	1	EDGING, Rubber, Twin (Used on 18HP Models)
0320	1736025	1	GUARD, Pulley
0340	7070814	2	TRIM
0360	1930601	3	SCREW, Hex Washer Head, Taptite, 5/16-18 x 5/8
0380	885810	1	SPACER, Lower
0390	885815	1	HARNESS, Ogura
1270	1727979	1	EXHAUST PIPE, RH (Used on 18HP Models)
1280	1727980	1	EXHAUST PIPE, LH (Used on 18HP Models)

Footnotes:

Note* To verify your specific engine model, please reference the ID Tag located on your engine. See your local Briggs & Stratton distributor for parts and service.

Note: ** Purchase engine parts from engine manufacture dealer.

Transmission Group

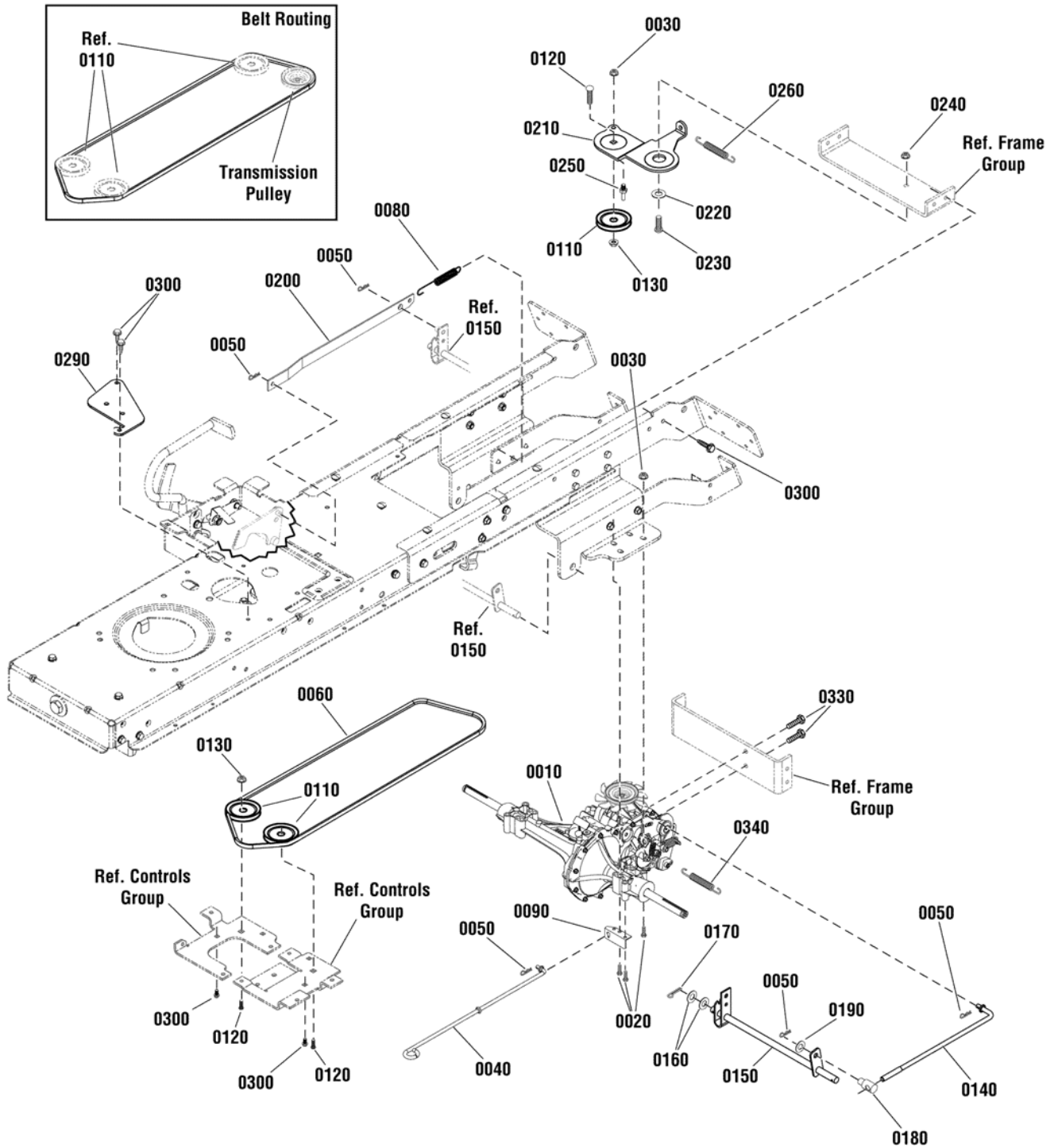

Item	Part No	Qty	Description
0010	885528	1	* TRANSMISSION, Hydro Gear, 610
0020	1923141	8	SCREW, Hex Head Flange Lock, 5/16-18 x 2-3/4, G5
0030	1931277	8	NUT, Hex Flange, Whiz Lock, 5/16-18
0040	885436	1	LEVER, Roll Release
0050	1722460	5	PIN, Quick
0060	885495	1	BELT, Secondary (81.37" EL, HA section)
0080	722481	1	SPRING, Extension
0090	7300701BM	1	BRACKET, Roll Release
0110	885645	3	PULLEY, Idler
0120	1931352	3	BOLT, Carriage, Short Neck, 3/8-16 x 1-1/2, G5
0130	720142	3	NUT, Hex Flange, Centerlock, 3/8-16
0140	885476	1	SPEED CONTROL, Short Link
0150	885477A	1	SPEED CONTROL ASSEMBLY
0160	720173	2	WASHER, Flat, 13/16
0170	1960074	1	PIN, Cotter
0180	727774	1	NUT, Adjusting
0190	720166	1	WASHER, Flat, .41
0200	885480	1	LINK, Speed Control
0210	885409A	1	BRACKET, Idler, Rear
0220	1727935	1	SPACER, Pivot
0230	1931335	1	BOLT, Carriage, Short Neck, 5/16-18 x 1, G5
0240	1931277	2	NUT, Hex Flange, Whiz Lock, 5/16-18
0250	885077	1	BELT GUIDE
0260	1731939	1	SPRING, Extension
0290	885681A	1	PLATE, Front Fixed Idler
0300	1664847	4	CAPSCREW, Hex Washer Head, Taptite, 5/16-18 x 3/4
0330	1664847	2	CAPSCREW, Hex Washer Head, Taptite, 5/16-18 x 3/4
0340	722494	1	SPRING, Extension

Footnotes:

Note* See your local authorized dealership for parts and warranty or contact Hydro Gear at www.hydro-gear.com/Support/NorthAmerica.aspx (U.S. 1-877-728-7410 Int'l 32 (0) 12 670 631)

Transmission SERVICE PARTS - Hydro Gear 324-0610

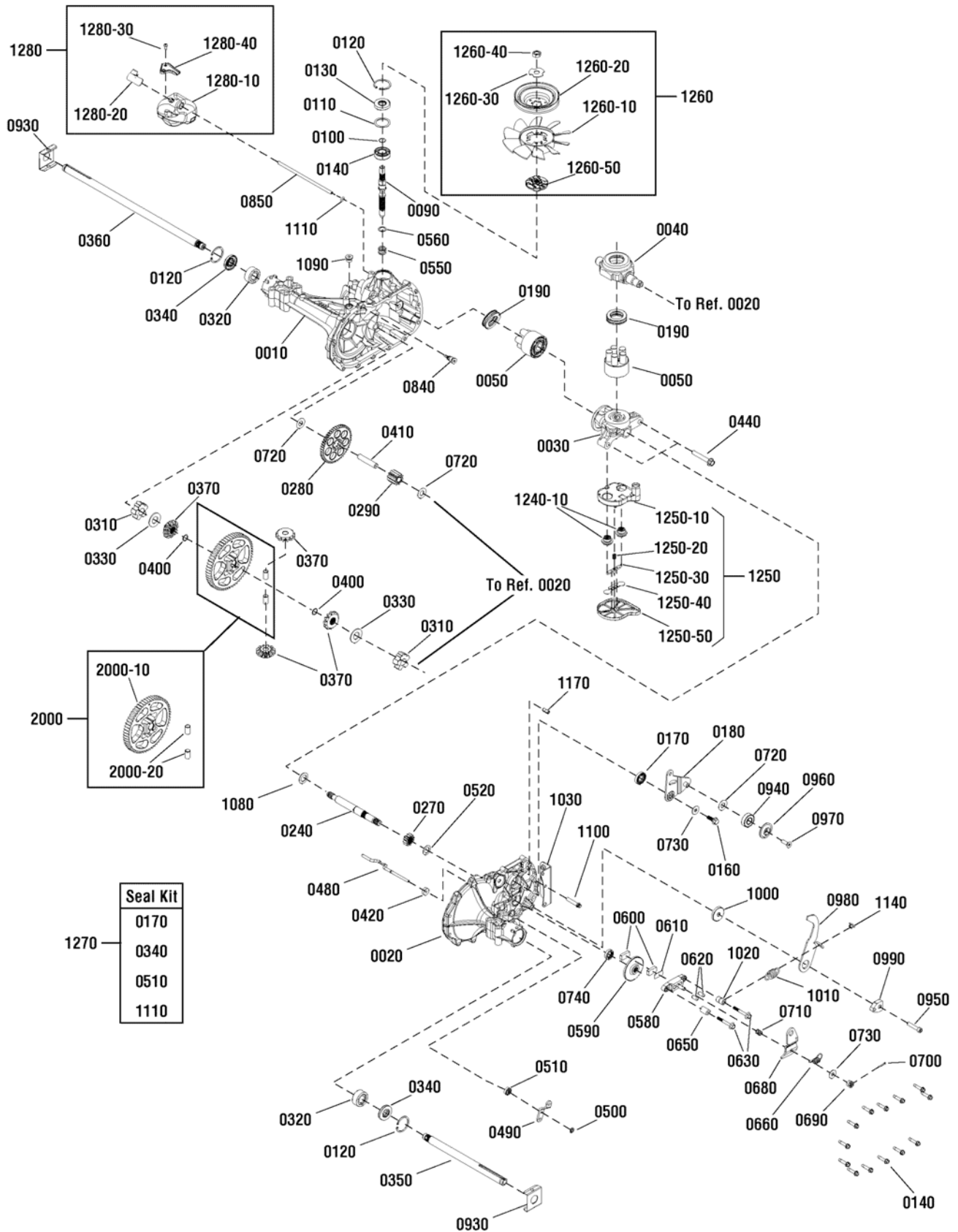

Transmission SERVICE PARTS - Hydro Gear 324-0610

Item	Part No	Qty	Description
0010	----	1	* MAIN HOUSING ASSEMBLY
0020	----	1	* SIDE HOUSING ASSEMBLY
0030	----	1	* CENTERSECTION ASSEMBLY
0040	----	1	* TRUNNION, Swashplate
0050	----	2	* BLOCK ASSEMBLY
0060	----	1	* SEALANT, 10.1 oz. (Not Illustrated)
0070	----	14	* SCREW, Hex Washer, 1/4-20 x 1-1/8
0090	1752461	1	SHAFT, Input
0100	1715270	1	RING, Retaining
0110	1752462	1	WASHER, Flat, 1.23 x 1.57 x .04
0120	1752463	3	RING, RETAINING
0130	1752464	1	SEAL, LIP 17 x 40 x 12
0140	1752465	1	BEARING, BALL 17 x 40 x 12
0160	----	1	* SCREW, Hex Flange, With Patch, 5/16-24 x 15/16
0170	----	1	* SEAL, Lip, 18 x 32 x 7 (Not a servicable part, order kit # 1270)
0180	----	1	* ARM, Control
0190	1715144	2	* BEARING, Thrust, 30 x 52 x 13
0240	----	1	* SHAFT, Motor
0270	----	1	* GEAR, Pinion, 12T
0280	----	1	* GEAR, 10T/49T
0290	----	1	* GEAR, Jackshaft, 10T
0310	----	2	* BUSHING, Sleeve (Inboard)
0320	----	2	* BUSHING, Sleeve, 3/4 x 1-1.571 x 5/8
0330	----	2	* WASHER, Flat, 3/4 x 1-1/2 x 7/64
0340	----	2	* SEAL, Lip, 3/4 x 1.577 x 1/4 (Not a servicable part, order kit # 1270)
0350	----	1	* SHAFT, Axle, 3/4 x 11.39 (Key, RH)
0360	----	1	* SHAFT, AXLE, 3/4 x 16.99 (Key, LH)
0370	----	1	* KIT, Miter Gear
0400	----	2	* RING, Retaining Spiral
0410	----	1	* PIN, Jackshaft, 1/2 x 2.43
0420	----	1	* MAGNET, Ring
0440	1717965	2	SCREW, Hex Flange, 3/8-24 x 2-1/2
0480	----	1	* ROD, Actuator Bypass
0490	----	1	* ARM, Bypass
0500	----	1	* RING, Retaining, External, 1/4
0510	----	1	* SEAL, Lip, 1/4 x 3/4 x 1/4 TC (Not a servicable part, order kit # 1270)
0520	----	1	* WASHER, Flat, 5/8 x 1 x 1/2
0530	----	1	* RING, Retaining
0540	----	1	* BUSHING, Center Block
0550	----	1	* SPRING, Block
0560	----	1	* WASHER, Thrust, .59 x .79 x .04
0580	----	1	* BRAKE YOKE KIT
0590	----	1	* DISK, Brake
0600	----	2	* PUCK, Brake

Footnotes:

Note* See your local authorized dealership for parts and warranty or contact Hydro Gear at www.hydro-gear.com/Support/NorthAmerica.aspx (U.S. 1-877-728-7410 Int'l 32 (0) 12 670 631)

Transmission SERVICE PARTS - Hydro Gear 324-0610

Item	Part No	Qty	Description
0610	----	1	* PLATE, Puck
0620	----	2	* PIN, Brake Actuating
0630	----	2	* SCREW, Hex Head, With Patch, 1/4-20 x 2
0650	1715199	1	SPACER, .26 x .57 x .87
0660	----	1	* SPRING, Brake arm Bias
0670	1706160	1	SCREW, Square Head, Ribbed, 5/16-24
0680	----	1	* ARM, Brake
0690	----	1	* NUT, Castle, 5/16-24
0700	----	1	* PIN, Cotter, 3/32 x 3/4
0710	----	1	* SPRING, Compression Brake, Anti-Drag
0720	----	3	* WASHER, Flat, .51 x 1.0 x .03
0730	----	2	* WASHER, Flat, .34 x .88 x .06
0740	----	1	* KIT, Seal
0840	----	1	* FITTING, 5/16 SAE 5/32 TUBE
0850	----	1	* HOSE, Expansion Tank, 7.56 In.
0930	1752466	2	SPRING CLIP, Housing Thrust (3/4" Axle)
0940	----	1	* BEARING, Ball, .62 x 1.38 x .44
0950	----	1	* CAPSCREW, Socket Head, 5/16-24 x 1-1/2
0960	----	1	* SPACER, Locating
0970	----	1	* SCREW, Countersunk, 5/16-18 x 1
0980	----	1	* ARM, Return
0990	----	1	* PUCK, Adjusting
1000	----	1	* WASHER, Flat, .32 x 1.60 x .24
1010	----	1	* SPRING, Extension, Double Loop
1020	----	1	* SPACER, .26 x .56 x .87
1030	----	1	* BRACKET, Torque
1080	----	1	* WASHER, Flat, .71 x 1.16 x .04
1090	----	1	* PLUG, 9/16-18 (METAL)
1100	----	1	* SCREW, Torx Head, 5/16-18 x 1-1/2
1110	----	1	* O-RING, .299 x .505 x .103 (Not a serviceable part, order kit # 1270)
1140	----	1	* SPRING, Guide
1170	----	1	* PIN, Spring, .304 x .75
1240	----	1	* CENTERSECTION ASSEMBLY, Filter, Bypass (Not Illustrated) (Includes Ref. Nos. 0030, 1240-10 & 1250)
1240-10	----	1	* CENTERSECTION (5-Piston) (Not a serviceable part, order kit #1240)
1250	----	1	* FILTER ASSEMBLY (Includes Ref. Nos. 1250-10, 1250-20, 1250-30, 1250-40 & 1250-50)
1250-10	----	1	* BASE, Filter, With Poppet (Not a serviceable part, order kit #1250)
1250-20	----	1	* SPRING, Bypass, 1/2" (Not a serviceable part, order kit #1250)
1250-30	----	1	* ACTUATOR, Bypass (Not a serviceable part, order kit #1250)
1250-40	----	1	* DEFLECTOR (Not a serviceable part, order kit #1250)
1250-50	----	1	* BOTTOM, Filter (Not a serviceable part, order kit #1250)
1260	1752467	1	FAN & PULLEY KIT (Includes Ref. Nos. 1260-10, 1260-20, 1260-30, 1260-40 & 1260-50)
1260-10	----	1	* FAN, 7" (10 BLADE) (Not a serviceable part, order kit #1260)
1260-20	----	1	* PULLEY, Cupped, 4-1/2" (Not a serviceable part, order kit #1260)

Footnotes:

Note* See your local authorized dealership for parts and warranty or contact Hydro Gear at www.hydro-gear.com/Support/NorthAmerica.aspx (U.S. 1-877-728-7410 Int'l 32 (0) 12 670 631)

Transmission SERVICE PARTS - Hydro Gear 324-0610

Item	Part No	Qty	Description
1260-30	-----	1	* NUT, Hex Jam, With Patch, 1/2-20 (Not a serviceable part, order kit #1260)
1260-40	-----	1	* WASHER, Slotted, .53 x 1.63 x .06 (Not a serviceable part, order kit #1260)
1260-50	-----	1	* HUB, Pulley (Not a serviceable part, order kit #1260)
1270	1752468	1	SEAL & O-RING KIT (Includes Ref. Nos. 0170, 0340, 0510 & 1110)
1280	1752469	1	EXPANSION TANK KIT (Includes Ref. Nos. 1280-10, 1280-20, 1280-30 & 1280-40)
1280-10	-----	1	* TANK, Expansion (Not a serviceable part, order kit #1280)
1280-20	-----	1	* CAP, Expansion Tank (Not a serviceable part, order kit #1280)
1280-30	-----	1	* BOLT, Self Tapping, 10-32 x 1/2 (Not a serviceable part, order kit #1280)
1280-40	-----	1	* BRACKET, Expansion Tank (Not a serviceable part, order kit #1280)
2000	-----	1	* KIT, 60T Bull Gear Diff Pins (Includes Ref. Nos. 2000-10 & 2000-20)
2000-10	-----	1	* GEAR, 60T
2000-20	-----	2	* PIN, 1/2

Not for
Reproduction

Footnotes:

Note* See your local authorized dealership for parts and warranty or contact Hydro Gear at www.hydro-gear.com/Support/NorthAmerica.aspx (U.S. 1-877-728-7410 Int'l 32 (0) 12 670 631)

Lift Group

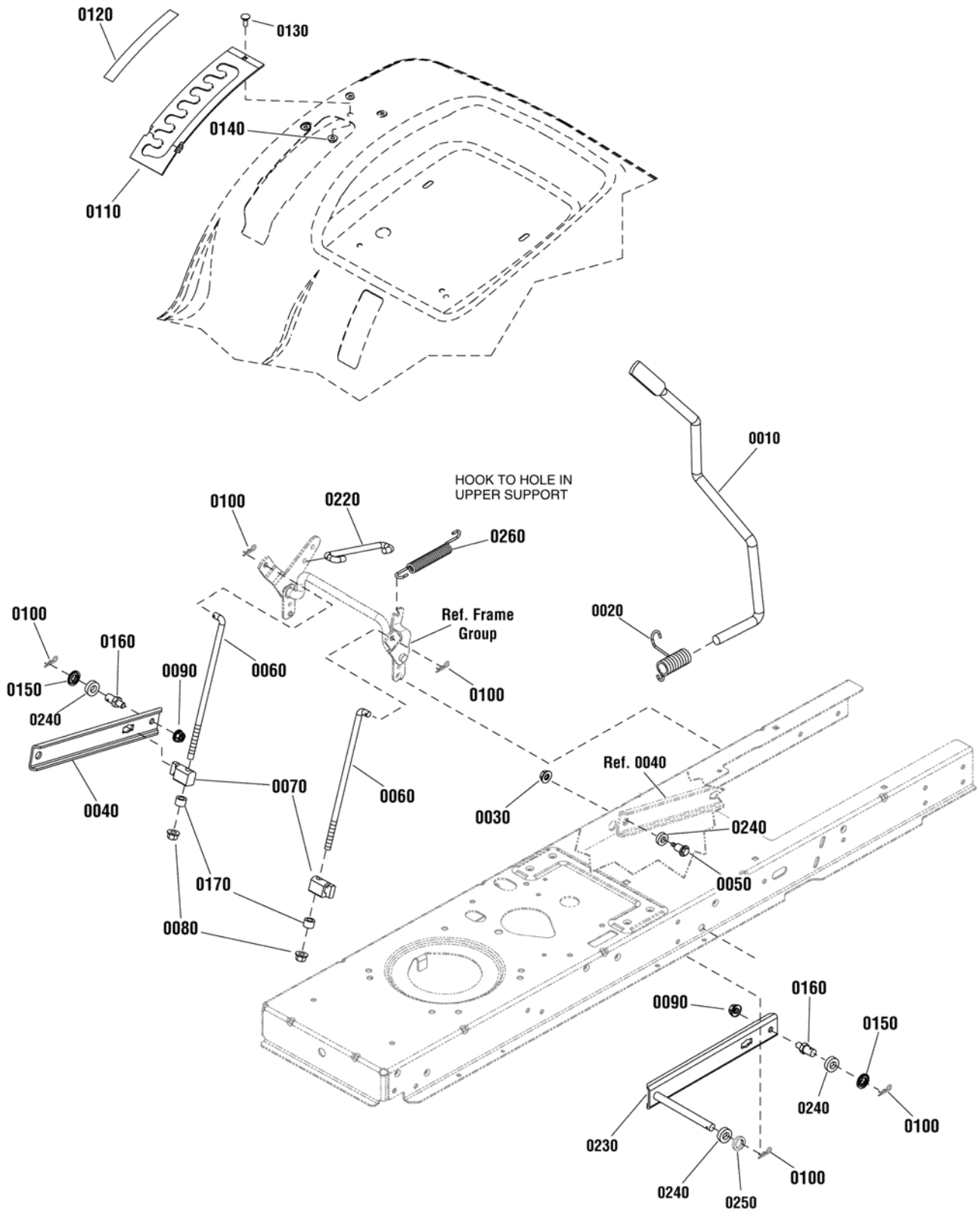

Item	Part No	Qty	Description
0010	1728070	1	ROD, Lift Handle, 17.7"
0020	1729652	1	SPRING, Torsion, 2.12 Inch
0030	1931277	1	NUT, Hex, Flange Whizlock, 5/16-18
0040	1731417BM	1	ARM, Rear Lift, RH
0050	1732426	1	BOLT, Shoulder
0060	1727955	2	ROD, Lower Life, 10.00 LG
0070	1731894	2	TRUNNION
0080	1960687	2	NUT, Hex Flange, 3/8-16 ESNA
0090	1931211	2	NUT, Hex, Flange Lock, 3/8-16
0100	1960074	5	CLIP, Spring
0110	1727985A	1	QUADRANT, Lift Height
0120	1730264	1	DECAL, Height Of Cut
0130	1960252	1	BOLT, Carriage, 1/4-20 x 5/8 G5
0140	1930641	1	NUT, Hex Flange Whiz, 1/4-20
0150	1960170	2	WASHER, 1/2
0160	721221	2	PIN, Threaded Shoulder
0170	1666294	2	SPACER
0220	1727954	1	ROD, Lift, 5.43 LG
0230	885523BM	1	ARM, Rear Lift, LH
0240	885382	4	WASHER, Rubber
0250	720173	1	WASHER, Flat, .81
0260	722453	1	SPRING, Extension

Not for
Reproduction**Footnotes:**

38" Mower Deck - Housing, Arbors & Blade

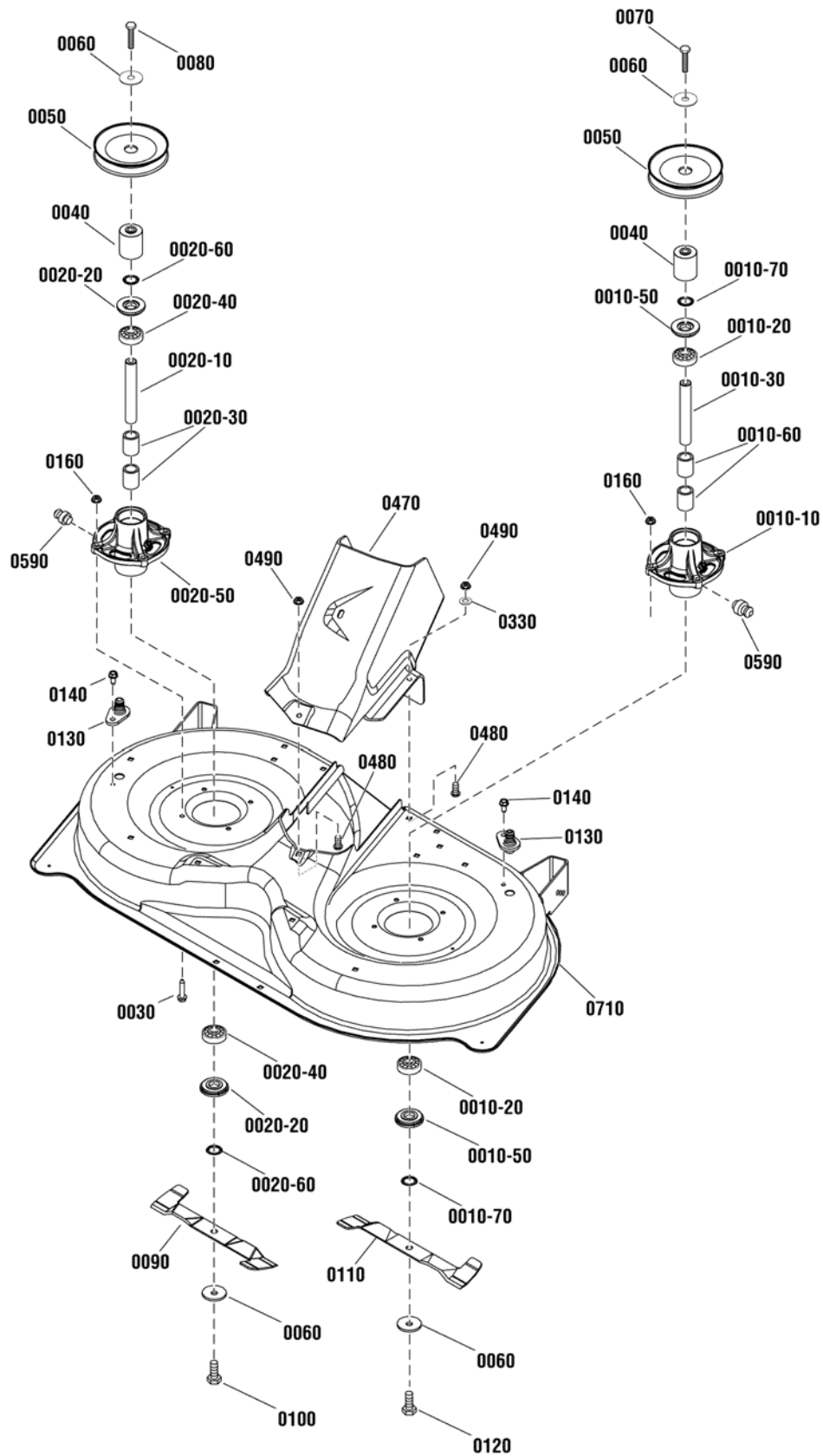

38" Mower Deck - Housing, Arbors & Blade

Item	Part No	Qty	Description
0010-10	1735573	2	HOUSING, Spindle
0010-20	1735399	4	BEARING, Ball, 20mm
0010-30	1735326	1	SHAFT, Spindle, LH
0010-50	1735323	4	SHIELD, Arbor
0010-60	1735328	4	SPACER, Bearing
0010-70	1960766	4	RING, Self Locking
0020-10	885420	1	SHAFT, Spindle, RH (LH Thread)
0020-20	1735323	4	SHIELD, Arbor
0020-30	1735328	4	SPACER, Bearing
0020-40	1735399	4	BEARING, Ball, 20mm
0020-50	1735573	2	HOUSING, Spindle
0020-60	1960766	4	RING, Self Locking
0030	1930600	8	CAPSCREW, Hex Washer Head, Taptite, 5/16-18 x 1-1/2
0040	1750338	2	SPACER, Mower Drive
0050	1737835	2	PULLEY, Deep Groove
0060	1656916	4	WASHER, Spring, 0.475ID x 1-3/4 OD
0070	1926110	1	CAPSCREW, Hex Head, 7/16-14 x 2-3/4, G5
0080	885456	1	CAPSCREW, Socket Head, 7/16-14 x 2-3/4, LH
0090	885418BM	1	BLADE, RH, 19.5"
0100	885455	1	CAPSCREW, Socket Head, 7/16-14 x 1, LH
0110	885419BM	1	BLADE, LH, 19.5"
0120	1920676	1	CAPSCREW, Hex Head, 7/16-14 x 1, G5
0130	1735716	2	ADAPTER, Washout Port
0140	1664847	2	CAPSCREW, Hex Washer Head, Taptite, 5/16-18 x 3/4
0160	1931277	6	NUT, Hex Flange, Whiz Lock, 5/16-18
0330	1919326	3	WASHER, 5/16
0470	885460	1	DECK, CENTER CAP
0480	1931333	3	BOLT, Carriage, Short Neck, 5/16-18 x 3/4, G5
0490	1931277	3	NUT, Hex Flange, Whiz Lock, 5/16-18
0590	1704314	2	FITTING, Grease
0710	885557BM	1	DECK ASSEMBLY

Footnotes:

38" Mower Deck - Clutch Group

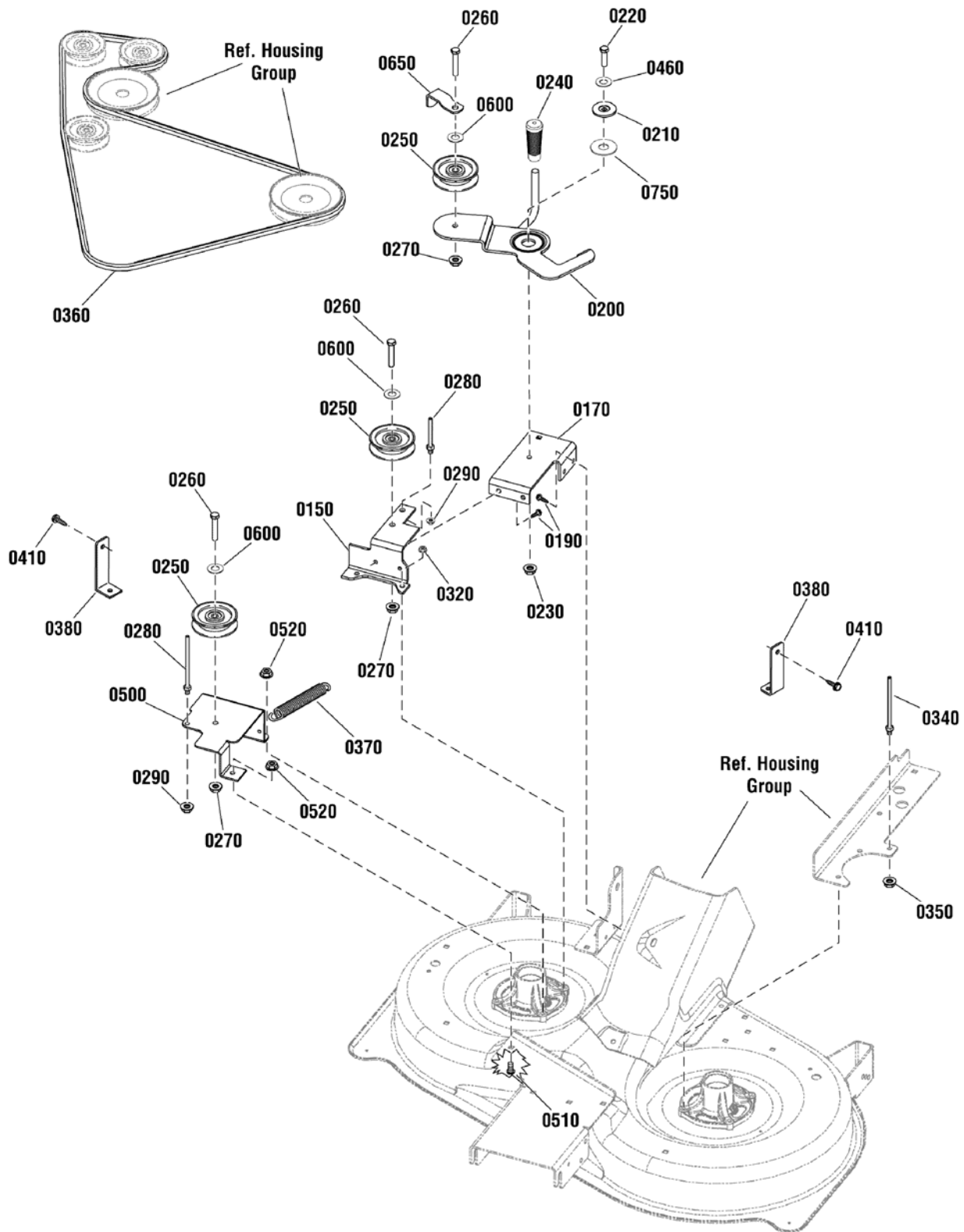

Item	Part No	Qty	Description
0150	885481BM	1	BRACKET, Idler, RH
0170	885516BM	1	SUPPORT, Idler Arm
0190	1664847	4	CAPSCREW, Hex Washer Head, Taptite, 5/16-18 x 3/4
0200	885559BM	1	DECK IDLER ASSEMBLY
0210	1727935	1	SPACER, Pivot, 0.330ID 1.76OD
0220	1921333	1	CAPSCREW, Hex Head, 5/16-18 x 1, G5
0230	720145	1	NUT, Hex Flange, Center Lock, 5/16-18
0240	721120	1	GRIP
0250	885482	3	PULLEY, Deck Idler
0260	1923701	3	CAPSCREW, Hex Head, 3/8-16 x 2, G5
0270	1931211	3	NUT, Hex Flange, Whiz Lock, 3/8-16
0280	885534	2	BELT GUIDE
0290	1931277	2	NUT, Hex Flange, Whiz Lock, 5/16-18
0320	1931277	2	NUT, Hex Flange, Whiz Lock, 5/16-18
0340	721974	1	BELT GUIDE, Long
0350	1931277	1	NUT, Hex Flange, Whiz Lock, 5/16-18
0360	885483	1	BELT, Deck (91.35" EL, HAA section)
0370	1715435	1	SPRING, Extension, 1
0380	885527BM	2	UPSTOP
0410	1664847	4	CAPSCREW, Hex Washer Head, 5/16-18 x 3/4
0460	1919326	1	WASHER, 5/16
0500	885556BM	1	BRACKET, Idler, Fixed
0510	1921333	1	CAPSCREW, Hex Head, 5/16-18 x 1, G5
0520	1931277	3	NUT, Hex Flange, Whiz Lock, 5/16-18
0600	1922755	3	WASHER, Flat, 3/8
0650	1677135BM	1	GUARD, Spring
0750	885649	1	SHIM

Footnotes:

38" Mower Deck - Support Group

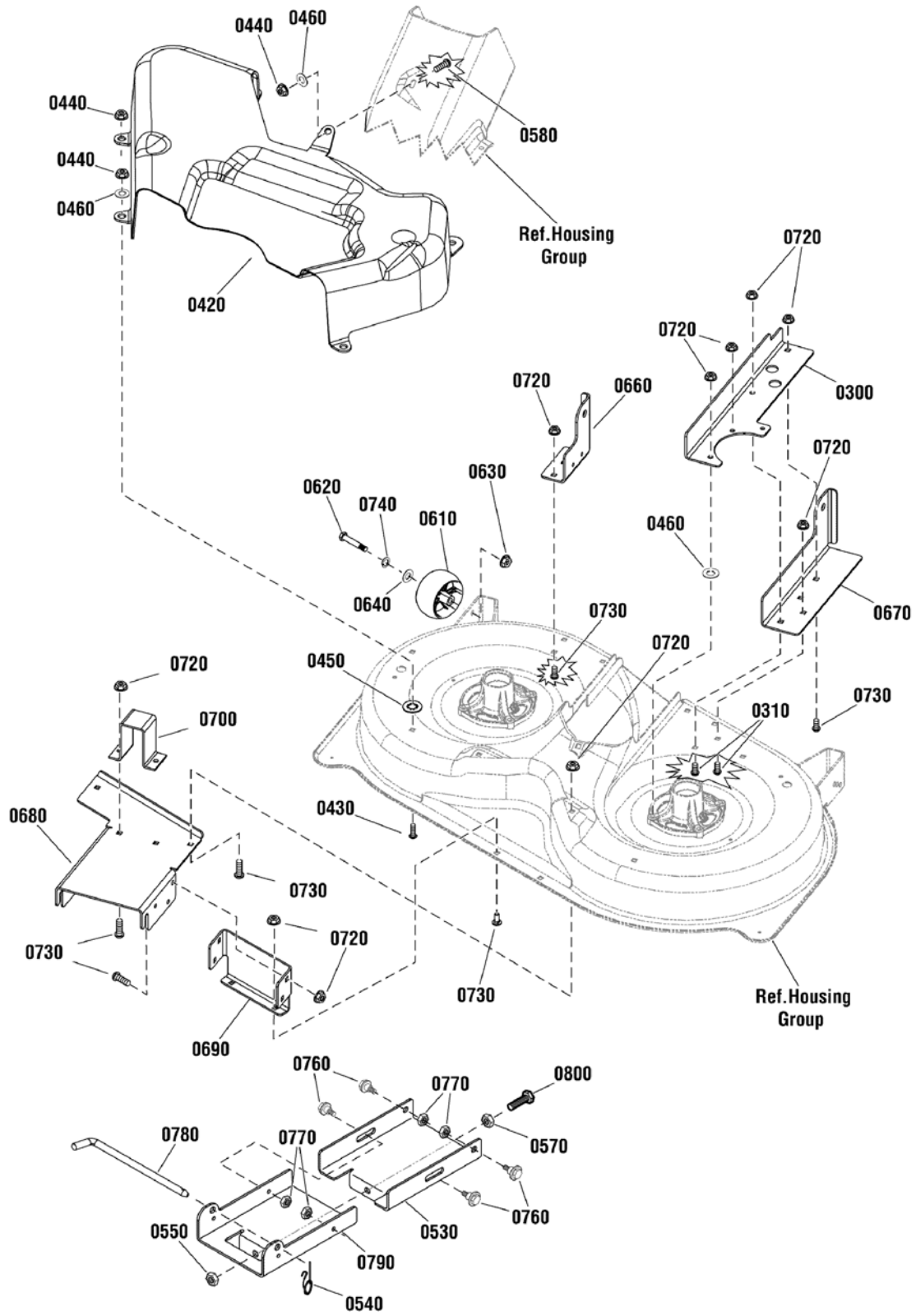

Item	Part No	Qty	Description
0300	885526BM	1	BRACKET, Rear Lift, LH
0310	1931333	2	BOLT, Carriage, Short Square Neck, 5/16-18 x 3/4, G5
0420	885543	1	COVER, Pulley
0430	1931333	5	BOLT, Carriage, Short Neck, 5/16-18 x 3/4, G5
0440	1931277	6	NUT, Hex Flange, Whiz Lock, 5/16-18
0450	5025498	6	NUT, Push On, 5/16
0460	1919326	6	WASHER, 5/16
0530	885734BM	1	BRACKET, Front Connector
0540	2176012	1	RETAINER, Pin Spring
0550	1960379	1	NUT, Hex Lock, ESNA LIGHT, 1/2-13
0570	1913744	1	NUT, Hex Jam, 1/2-13
0580	720049	1	BOLT, Carriage, 5/16-18 x 5/8
0610	1714760	2	WHEEL, Gauge
0620	2108765	2	BOLT, 3/8-16 x 2-3/4
0630	1960687	2	NUT, Hex Flange, ESNA, 3/8-16
0640	1960170	2	WASHER, 1/2
0660	885462BM	1	BRACKET, Deck, Rear
0670	885463BM	1	BRACKET, Rear Lift, LH
0680	885738BM	1	SUPPORT, Deck Front
0690	885740BM	1	BRACKET, Front Support
0700	885519BM	1	BRACKET, Front Upstop
0720	1931277	14	NUT, Hex Flange, Whiz Lock, 5/16-18
0730	1931333	14	BOLT, Carriage, Short Neck, 5/16-18 x 3/4, G5
0740	720035	2	WASHER, Spring, .30" ID
0760	1732426	4	BOLT, Shoulder, 5/16-18 x .13/16, 1/2" Thread Length
0770	1931277	4	NUT, Hex Flange, Whiz Lock, 5/16-18
0780	1731414	1	ROD, Latch
0790	885699BM	1	BRACKET, Front Hanger
0800	885710	1	BOLT, 1/2 x 3

Footnotes:

Guard Group - 38" RD

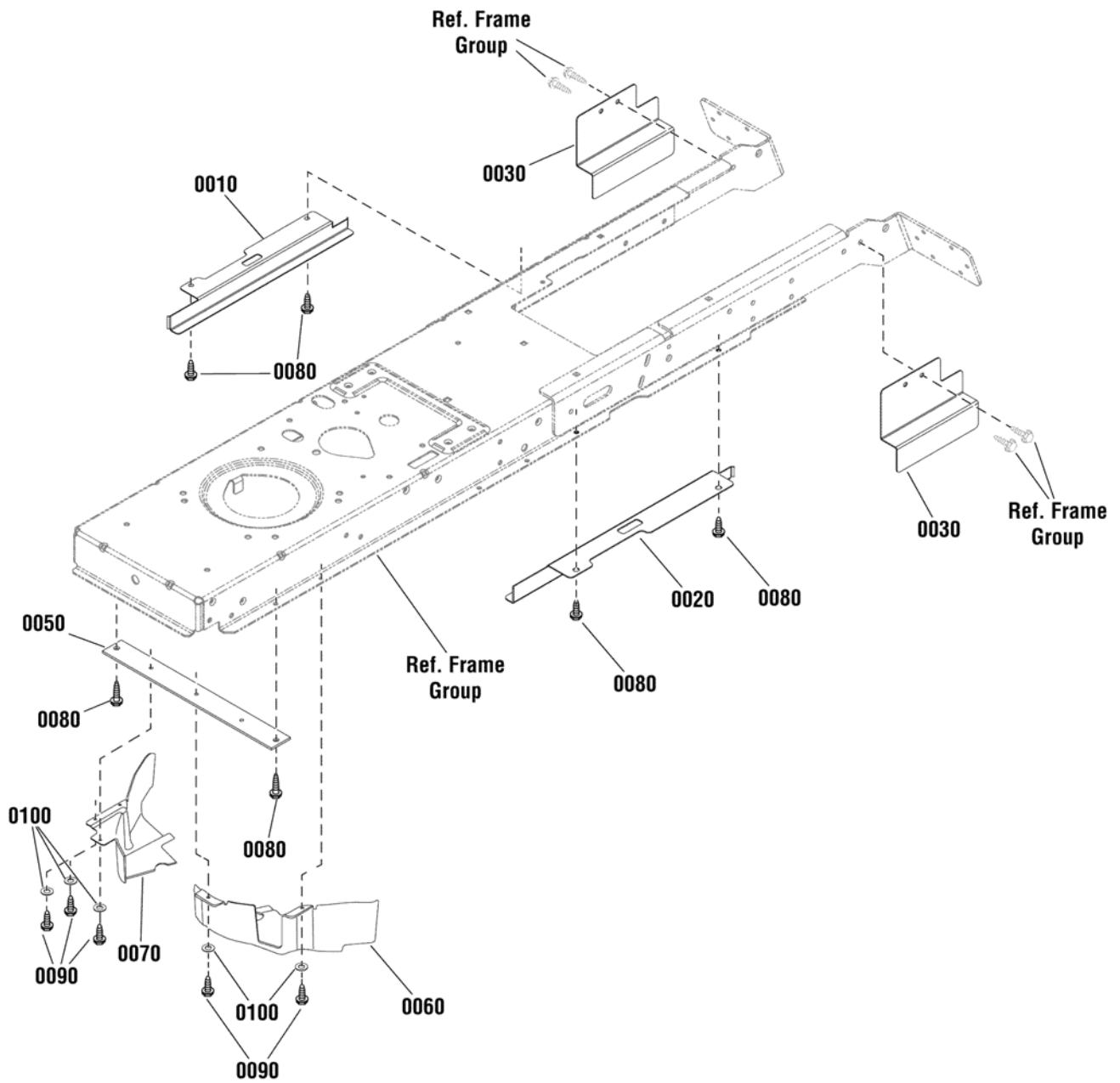

Item	Part No	Qty	Description
0010	885598BM	1	GUARD, Middle Right
0020	885599BM	1	GUARD, Middle Left
0030	885600BM	2	GUARD, Rear
0050	885602BM	1	BRACE, Guard
0060	885604	1	GUARD, Front, LH
0070	885605	1	GUARD, Front, RH
0080	1664847	6	CAPSCREW, Hex Washer Head, Taptite, 5/16-18 x 3/4
0090	1925003	5	CAPSCREW, Hex Washer Head, Taptite, 1/4-20 x 1/2
0100	2821319	5	WASHER, 1/4

Not for
Reproduction

Footnotes:

Item	Part No	Qty	Description
0010	885560	1	FRAME ASSEMBLY
0010-10	720057	23	BOLT, Carriage, 1/4-20 X 5/8 (Included in Ref. 0010)
0010-20	885413A	1	FRAME, Upper (Included in Ref. 0010)
0010-30	885416A	1	SUPPORT, Dump Handle (Included in Ref. 0010)
0010-40	885507A	1	CROSS BRACE (Included in Ref. 0010)
0010-50	885514A	2	BRACKET, Mounting, Long (Included in Ref. 0010)
0010-60	885520A	1	SUPPORT STRAP, Dump Handle (Included in Ref. 0010)
0010-70	885525A	1	SUPPORT, Back, Frame (Included in Ref. 0010)
0010-80	885561A	1	BAGGER LOCATOR ASSEMBLY, LH (Included in Ref. 0010)
0010-90	885562A	1	BAGGER LOCATOR ASSEMBLY, RH (Included in Ref. 0010)
0010-100	1930641	23	NUT, Hex Flange, 1/4-20 (Included in Ref. 0010)
0020	1664847	4	CAPSCREW, Hex Washer Head, Taptite, 5/16-18 x 3/4
0030	1931202	8	CAPSCREW, Hex Washer Head, Taptite, 5/16-18 x 1-1/4
0040	720139	10	NUT, Hex Flange, Serrated, 5/16-18
0050	1664847	2	CAPSCREW, Hex Washer Head, Taptite, 5/16-18 x 3/4
0060	885400	1	COVER, Transition
0070	1664847	4	CAPSCREW, Hex Washer Head, Taptite, 5/16-18 x 3/4
0080	1919326	4	WASHER, 5/16
0090	722494	2	SPRING, Extension
0100	885461	1	CHUTE
0110	1960170	2	WASHER, 1/2
0120	1960074	2	CLIP, Hair Pin
0130	885651A	1	BACK PLATE
0140	885470A	1	BRACE, Lower Back Plate
0150	1664847	7	CAPSCREW, Hex Washer Head, Taptite, 5/16-18 x 3/4
0160	721221	2	PIN, Threaded Shoulder
0170	885494A	1	PLATE, Rotation, RH
0180	885473A	1	PLATE, Rotation, LH
0190	1931333	4	BOLT, Carriage, Short Neck, 5/16-18 x 3/4, G5
0200	720139	4	NUT, Hex Flange, Serrated, 5/16-18
0210	885566A	1	FRAME, Bagger
0220	885573	1	SWITCH, Bag Full
0230	880760	2	SCREW, Plastite, #10-14 x 7/8
0240	885497A	1	BRACKET, Bagger Latch
0250	885496A	2	LATCH, Bagger
0260	720091	2	BOLT, Shoulder
0270	720142	4	NUT, Hex Flange, Center Lock, 3/8-16
0280	885489A	1	PLATE, Switch
0290	720057	2	BOLT, Carriage, 1/4-20 x 5/8
0300	1930641	2	NUT, Hex Flange, Whiz Lock, 1/4-20
0310	885618	1	COVER, Bag Full Switch
0320	722858	4	CAPSCREW, 5/16-18 x 3/4
0330	885652A	1	SUPPORT, Bagger, LH
0340	885653A	1	SUPPORT, Bagger, RH

Footnotes:

Item	Part No	Qty	Description
1040	720033	1	CAPSCREW, Hex Flange Lock, 1/4-20 x 1-1/4
1050	720146	1	NUT, Hex Flange, Lock, 1/4-20
1060	885564	2	SCREW, Torx, 1/4-20
1070	7091016	4	SCREW, Hex Washer Head, Self Tap, 1/4-20 x 5/8
1080	1960593	8	BOLT, Carriage, 1/4-20 x 5/8
1090	1930641	8	NUT, Hex Flange, Whiz Lock, 1/4-20
1190	885401	1	COVER, Collector, Red
1200	885510	1	BAG, Collector
1210-10	885433	1	ADJUSTER, Bagger Handle
1210-20	885518A	1	HANDLE, Bagger
1210-30	1723359	1	GRIP, Lift Rod
1220	885425A	1	HANDLE, Front
1230	885430A	1	HANDLE, Back
1240	885429A	2	STIFFENER

Not for
Reproduction

Footnotes:

Decal Group

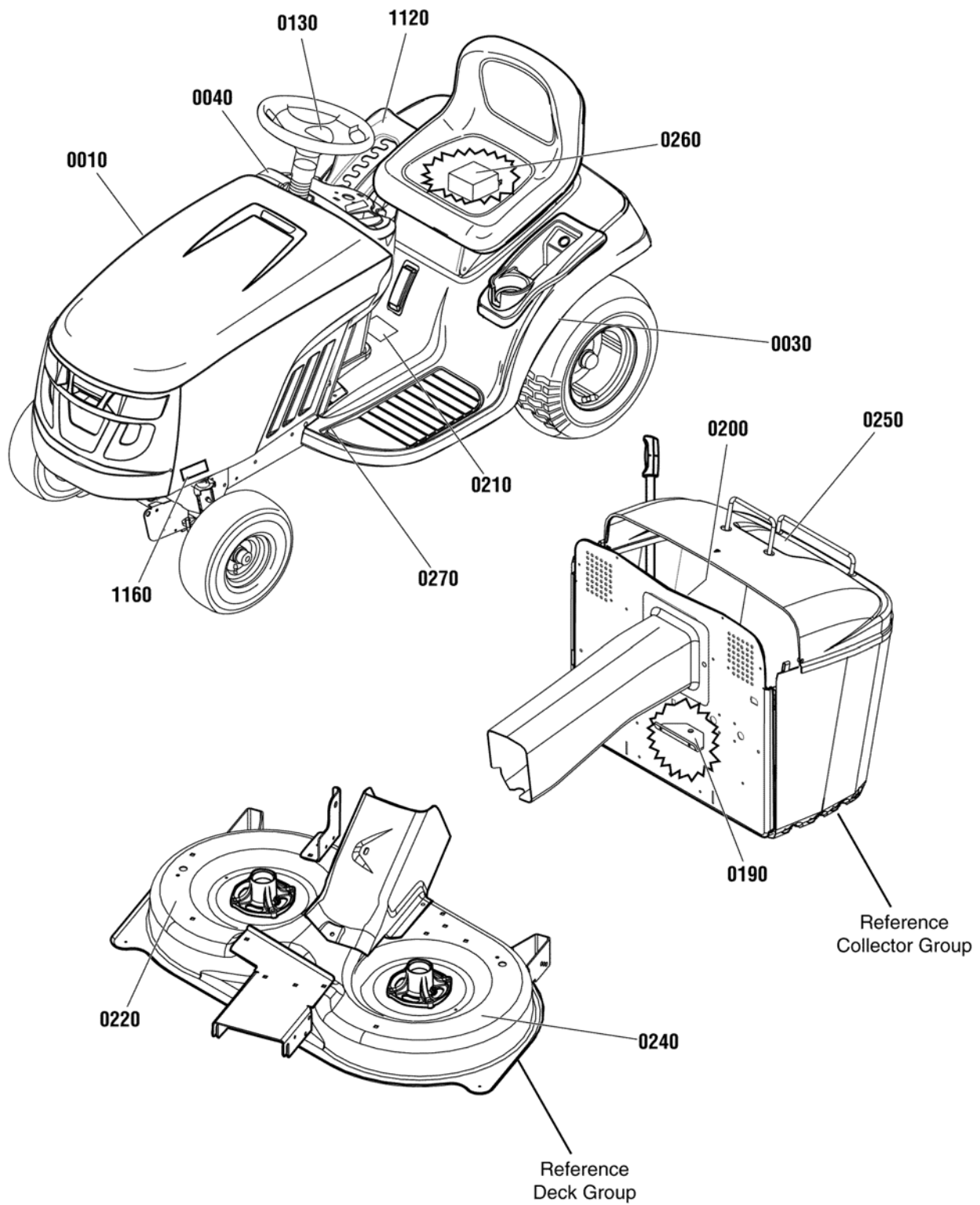

Item	Part No	Qty	Description
0010	1751632	2	DECAL, Logo, Hood
0030	7101935	1	DECAL, Roll Release
0040	885749	1	DECAL, Ignition Switch Symbols
0130	1739085	1	DECAL, Steering Wheel
0190	729677	1	DECAL, Drawbar Warning Symbol
0200	1721107	1	DECAL, Discharge Tube Symbols
0210	1723175	1	DECAL, Tunnel
0220	1720389	2	DECAL, Danger Rotation Blade Symbols
0240	885625	1	DECAL, Cutting Width
0250	1751401	1	DECAL, Shroud
0260	885816	1	DECAL, Battery
0270	729695	1	DECAL, Clutch/Brake
1120	1730264	1	DECAL, Height of Cut
1160	885736	1	DECAL, Model, ELT17538RDF
1160	885705	1	DECAL, Model, ELT1838RDF

Not for
Reproduction

Footnotes:

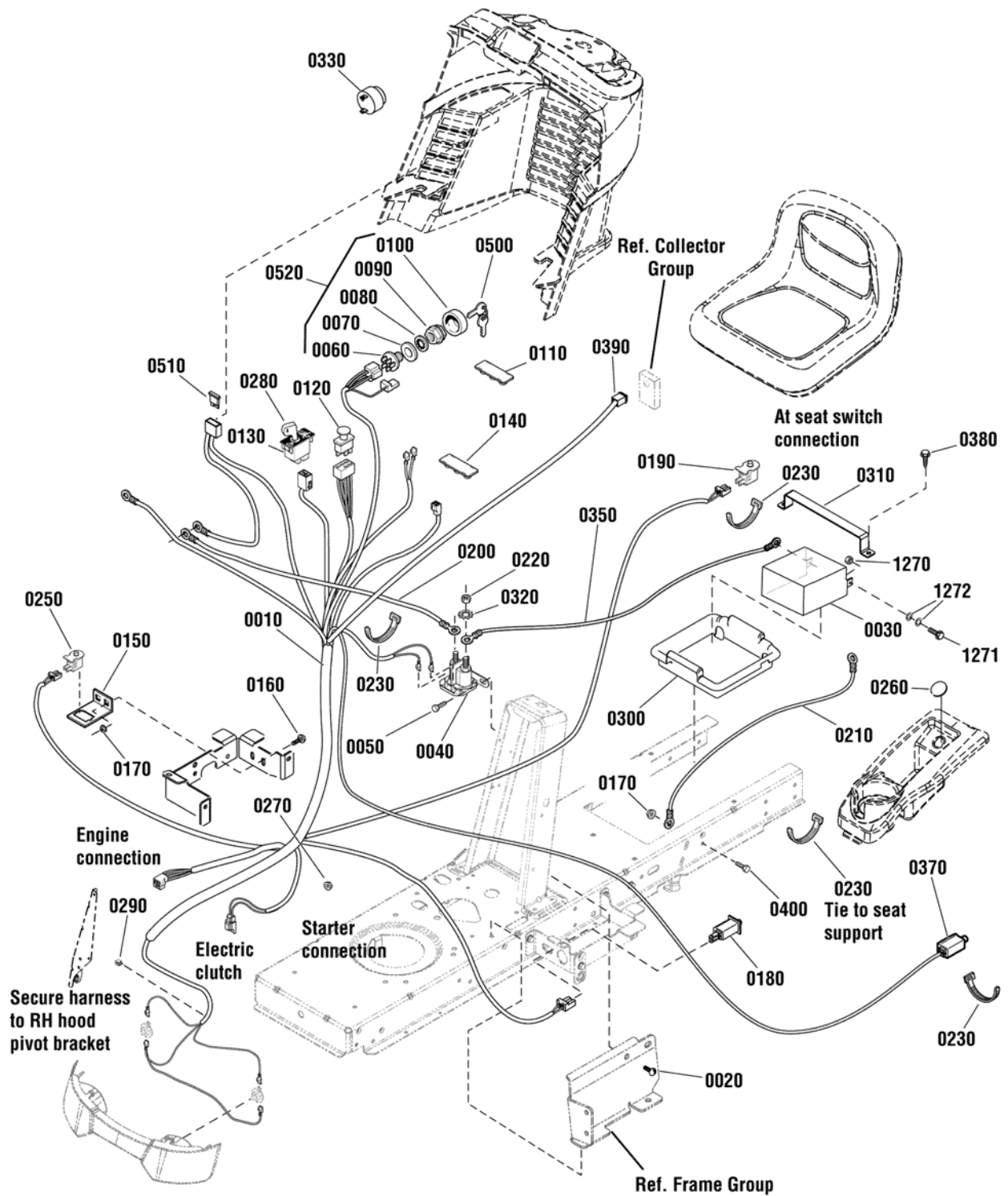

Item	Part No	Qty	Description
0010	885691	1	WIRING HARNESS
0020	1930601	5	CAPSCREW, Hex Washer Head, Taptite, 5/16-18 x 5/8
0030	-----	1	BATTERY, 12 Volt
0040	1728963	1	SOLENOID
0050	1925003	2	CAPSCREW, Hex Washer Head, Taptite, 1/4-20 x 1/2
0060	721108	1	SWITCH ASSEMBLY, Ignition
0070	2101025	1	WASHER, 5/8
0080	1960547	1	LOCKWASHER, Internal Tooth
0090	1717549	1	NUT, Hex Flange, 5/8-32
0100	1717550	1	COVER, Switch
0110	1729993	1	PLUG, Hour Meter
0120	1722887	1	SWITCH, PTO Push
0130	1726556	1	SWITCH, RMO Module Only
0140	1722611	2	PLUG, Hole
0150	1728026A	1	SUPPORT, RMO Switch
0160	1931333	2	BOLT, Carriage, 5/16-18 x 3/4 G5
0170	1931277	3	NUT, Hex Flange Whiz Lock Small, 5/16-18
0180	7022886	1	SWITCH, Push Button (NO / NC)
0190	7023354	1	SWITCH, Push Button (NC)
0200	1721830	1	CABLE, # 6 x 25, Red
0210	1713163	1	CABLE, # 6 x 26, Black
0220	2860750	2	NUT, Hex, KEPS, 5/16-24
0230	1701011	16	TIE, Self Locking
0250	1732004	1	SWITCH, Push Button (NO)
0260	1732007	1	PLUG, Hole
0270	1960294	1	NUT, Hex Flange Whiz Lock Small, 1/4-20
0280	1726557	2	KEY, RMO Module Plastic
0290	2172434	1	CLIP, Wire
0300	885428	1	CONTAINER, Battery
0310	885511BM	1	HOLD DOWN, Battery
0320	2820426	2	LOCKWASHER, 5/16
0330	1720117	1	BUZZER, Bag Full
0350	885616	1	CABLE, Battery
0370	727831	1	SWITCH, Bagger
0380	1664847	2	SCREW, Hex Washer Head, Taptite, 5/16-18 x 3/4
0390	885692	1	HARNESS, Bag Full
0400	7091811	1	CAPSCREW, Hex Flange, 5/16-18 x 5/8, G5
0500	1737837	1	KEYS, Ignition
0510	-----	1	* FUSE, 20 Amp
0520	1686734	1	SWITCH ASSEMBLY (Includes Ref Nos. 0060, 0070, 0080, 0090 & 0100)
1270	51716	2	NUT, M5 x 0.8

Footnotes:

Note* See your local hardware store for replacement fuses.

Item	Part No	Qty	Description
1271	52618	2	SCREW, M5 x 0.8 x 12
1272	51713	4	WASHER, M5

Not for
Reproduction

Footnotes:

Note* See your local hardware store for replacement fuses.

Hardware Identification & Torque Specifications

Torque Specification Chart								
FOR STANDARD METRIC MACHINE HARDWARE (Tolerance ± 20%)								
Property Class	5.6		8.8		10.9		12.9	
	Class 5.6		Class 8.8		Class 10.9		Class 12.9	
Size Of Hardware	in/lbs		in/lbs		in/lbs		in/lbs	
	ft/lbs	Nm.	ft/lbs	Nm.	ft/lbs	Nm.	ft/lbs	Nm.
M3	5.88	.56	13.44	1.28	19.2	1.80	22.92	2.15
M4	13.44	1.28	30.72	2.90	43.44	4.10	52.56	4.95
M5	26.4	2.50	60.96	5.75	5.97	8.10	7.15	9.7
M6	44.64	4.3	7.3	9.9	10.3	14	12.1	16.5
M7	5.2	7.1	12.1	16.5	16.9	23	19.9	27
M8	7.7	10.5	17.7	24	25	34	29	40
M10	15	21	35	48	50	67	59	81
M12	26	36	61	83	86.2	117	103	140
M14	42	58	101	132	136	185	162	220
M16	64	88	147	200	210	285	250	340
M18	89	121	202	275	287	390	346	470
M20	126	171	290	390	405	550	486	660
M22	169	230	390	530	559	745	656	890
M24	217	295	497	375	708	960	840	1140
M27	320	435	733	995	1032	1400	1239	1680
M30	435	590	995	1350	1401	1900	1681	2280
M33	590	800	1349	1830	1902	2580	2278	3090
M36	759	1030	1740	2360	2441	3310	2935	3980
M39	988	1340	2249	3050	3163	4290	3798	5150

Torque Specification Chart						
FOR STANDARD MACHINE HARDWARE (Tolerance ± 20%)						
Hardware Grade	No Marks		SAE Grade 5		SAE Grade 8	
	SAE Grade 2		SAE Grade 5		SAE Grade 8	
Size Of Hardware	in/lbs		in/lbs		in/lbs	
	ft/lbs	Nm.	ft/lbs	Nm.	ft/lbs	Nm.
8-32	19	2.1	30	3.4	41	4.6
8-36	20	2.3	31	3.5	43	4.9
10-24	27	3.1	43	4.9	60	6.8
10-32	31	3.5	49	5.5	68	7.7
1/4-20	66	7.6	8	10.9	12	16.3
1/4-28	76	8.6	10	13.6	14	19.0
5/16-18	11	15.0	17	23.1	25	34.0
5/16-24	12	16.3	19	25.8	29	34.0
3/8-16	20	27.2	30	40.8	45	61.2
3/8-24	23	31.3	35	47.6	50	68.0
7/16-14	30	40.8	50	68.0	70	95.2
7/16-20	35	47.6	55	74.8	80	108.8
1/2-13	50	68.0	75	102.0	110	149.6
1/2-20	55	74.8	90	122.4	120	163.2
9/16-12	65	88.4	110	149.6	150	204.0
9/16-18	75	102.0	120	163.2	170	231.2
5/8-11	90	122.4	150	204.0	220	299.2
5/8-18	100	136	180	244.8	240	326.4
3/4-10	160	217.6	260	353.6	386	525.0
3/4-16	180	244.8	300	408.0	420	571.2
7/8-9	140	190.4	400	544.0	600	816.0
7/8-14	155	210.8	440	598.4	660	897.6
1-8	220	299.2	580	788.8	900	1,244.0
1-12	240	326.4	640	870.4	1,000	1,360.0

The guides and ruler furnished below are designed to help you select the appropriate hardware.

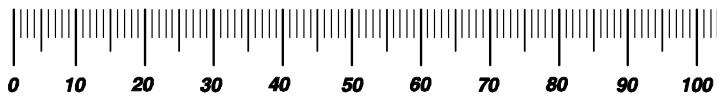

Nut, M8

Thread Diameter (mm)
Inside Diameter (in) Threads per inch

Nut, 1/2-16

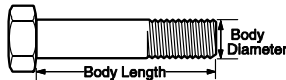

Screw, M8- 1.25 x 25

Thread Diameter (mm) Distance between threads (mm) Body Length (mm)
Body Diameter Threads per inch Body Length (in)

Screw, 1/2- 16 x 2

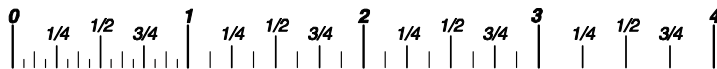

Standard Hardware Sizing

When a washer or nut is identified as 1/2" (M8), this is the *Nominal size*, meaning the *inside diameter* is 1/2 inch (8mm metric thread diameter); if a second number is present it represents the *threads per inch* (distance between threads).

When bolt or capscrew is identified as 1/2 - 16 x 2" (M8 - 1.25 x 50), this means the *Nominal size*, or body diameter is 1/2 inch (8mm metric thread diameter), the second number, 16, represents the *threads per inch*, (1.25 thread diameter). The final number is the body length of the bolt or screw, 2 inches (50mm).

NOTES

- These torque values are to be used for all hardware excluding: locknuts, self-tapping screws, thread forming screws, sheet metal screws and socket head setscrews.
- Recommended seating torque values for locknuts:
 - for prevailing torque locknuts - use 65% of grade 5 torques.
 - for flange whizlock nuts and screws - use 135% of grade 5 torques.
- Unless otherwise noted on assembly drawings, all torque values must meet this specification.

Common Hardware Types

Hex Head Capscrew



Washer



Carriage Bolt



Lockwasher



Hex Nut



Wrench & Fastener Size Guide

1/4" Bolt or Nut Wrench—7/16"	5/16" Bolt or Nut Wrench—1/2"	3/8" Bolt or Nut Wrench—9/16"	7/16" Bolt or Nut Wrench (Bolt)—5/8" Wrench (Nut)—11/16"	1/2" Bolt or Nut Wrench—3/4"
M6 Bolt or Nut Wrench—10mm	M8 Bolt or Nut Wrench—13mm	M10 Bolt or Nut Wrench—17mm	M12 Bolt or Nut Wrench—19mm	M14 Bolt or Nut Wrench—22mm

Parts Manual for

SNAPPER®

17.5 & 18 HP 38" REAR DISCHARGE EUROPEAN TRACTOR RD SERIES

Not for
Reproduction

IT IS THE POLICY OF BRIGGS & STRATTON CORP TO IMPROVE ITS PRODUCTS WHENEVER IT IS POSSIBLE AND PRACTICAL TO DO SO. WE RESERVE THE RIGHT TO MAKE CHANGES OR ADD IMPROVEMENTS AT ANY TIME WITHOUT INCURRING ANY OBLIGATION TO MAKE SUCH CHANGES ON PRODUCTS

Briggs & Stratton Yard Power Products Group

535 Macon Road
McDonough, GA, 30253 U.S.A.
800-935-2967

www.snapper.com

Copyright © 2012 Briggs & Stratton Corporation
Milwaukee, WI USA. All Rights Reserved

Manual No. 7105570

Revision: A 3/6/2012