

Regent Series

Lawn Tractors & Mower Decks

20HP Product

Mfg. No.	Description
2691075	Regent, 2040RD 20HP B&S Hydro and 40" Mower Deck (CE/Export)
2691076	Regent, 2040RDF 20HP B&S Hydro and 40" Mower Deck (CE/Export)

24HP Product

Mfg. No.	Description
2691077	Regent, 2440RD 24HP B&S Hydro and 40" Mower Deck (CE/Export)
2691078	Regent, 2440RDF 24HP B&S Hydro and 40" Mower Deck (CE/Export)

Not for
Reproduction

PRODUCT COMPONENTS	PAGES
Frame & Front Axle Group	4
Steering Group	6
Engine Group - 20HP & 24HP	8
Controls Group	10
Electrical Group	14
Hood, Grille & Dash Group	18
Seat Deck & Fuel Group	20
Mulching Flap Group	22
Lift Group - Manual	24
Wheels & Tires Group	26
Decals Group	28
Back Plate Group	30
Collector Group	32
French Guard Group	34
40" Mower Deck - Belt & Idler Arm Group	36
40" Mower Deck - Housing, Hitch, Arbors & Blades Group	40
Torque Specification Chart	Inside Back Cover

Not for
Reproduction

Frame & Front Axle Group

NOTE: Unless noted otherwise,
use the standard hardware torque
specification chart.

2988017a

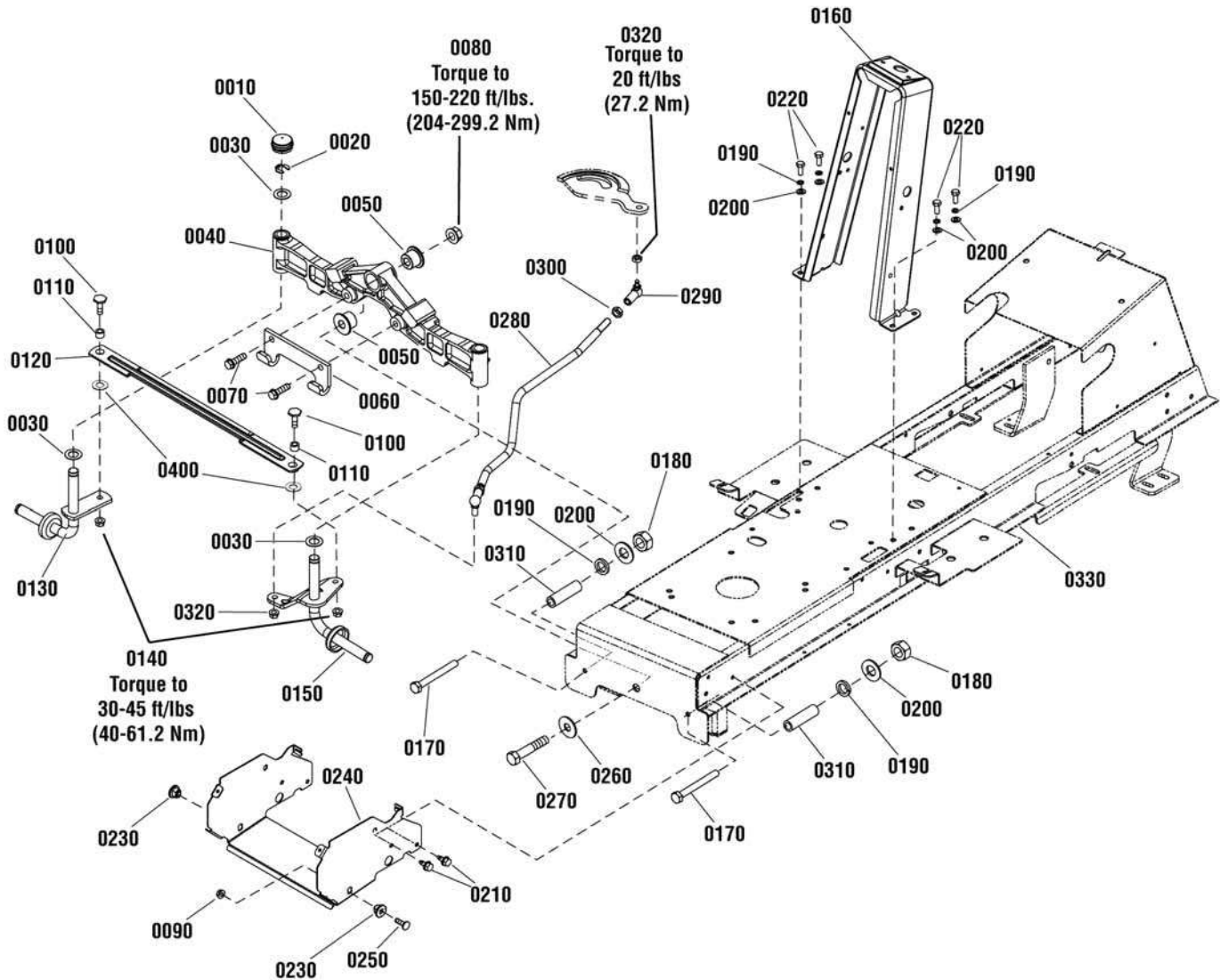

The above parts group applies to the following Mfg. Nos.:

- 2691075 - Regent
- 2691076 - Regent
- 2691077 - Regent
- 2691078 - Regent

Frame & Front Axle Group

REF NO	PART NO.	QTY.	DESCRIPTION
0010	1726504	2	HUB CAP
0020	1611710	2	RING, Klipping
0030	2860183	4	WASHER, 1-5/8
0040	1728018	1	AXLE, Front (Includes Ref. Nos. 0010, 0020, 0030, 0130 & 150)
0050	1730186	2	BUSHING, Axle Pivot
0060	1721918A	1	HOOK, Hitch 5/16 THK
0070	1960652	2	CAPSCREW, 7/16-14 x 1-1/2
0080	2860646	1	NUT, Hex Flange 5/8-11
0090	1931277	2	NUT, Hex Flange, 5/16-18
0100	1960032	2	CAPSCREW, Hex 3/8-16 x 1-1/4
0110	1731912	2	SPACER
0120	1751964A	1	ROD, Tie
0130	1727872A	1	SPINDLE & CUP ASSEMBLY, Right
0140	1930645	2	NUT, Hex Flange, 3/8-16
0150	1727873A	1	SPINDLE & CUP ASSEMBLY, Left
0160	885530A	1	TOWER
0170	1735874	2	BOLT, M8 x 75
0180	1735934	2	NUT, M8
0190	1735989	6	WASHER, 8.4
0200	1736000	6	WASHER, 8
0210	1930601	4	CAPSCREW, Hex Washer Head, Taptite, 5/16-18 x 5/8
0220	1735868	4	BOLT, M8 x 20
0230	1728086	2	PIVOT, Hood
0240	1735973	1	SUPPORT, Muffler
0250	1931335	2	BOLT, Carriage, 5/16-18 x 1
0260	1960035	1	WASHER, 5/8
0270	2860744	1	CAPSCREW, Hex, 5/8-11 x 3-1/4
0280	1735919	1	LINK, Drag
0290	1735851	2	BALL JOINT, CS16 M10-M12
0300	1735928	2	NUT, M12
0310	1735892	2	DISTANCE, Front axle 0-9521-29
0320	1735926	2	NUT, M10 DIN6923 8
0330	1736499	1	FRAME
0400	1960703	2	WASHER, 5/8

Footnotes

The above parts group applies to the following Mfg. Nos.:

2691075 - Regent
2691076 - Regent
2691077 - Regent
2691078 - Regent

Steering Group

NOTE: Unless noted otherwise,
use the standard hardware torque
specification chart.

2988023a

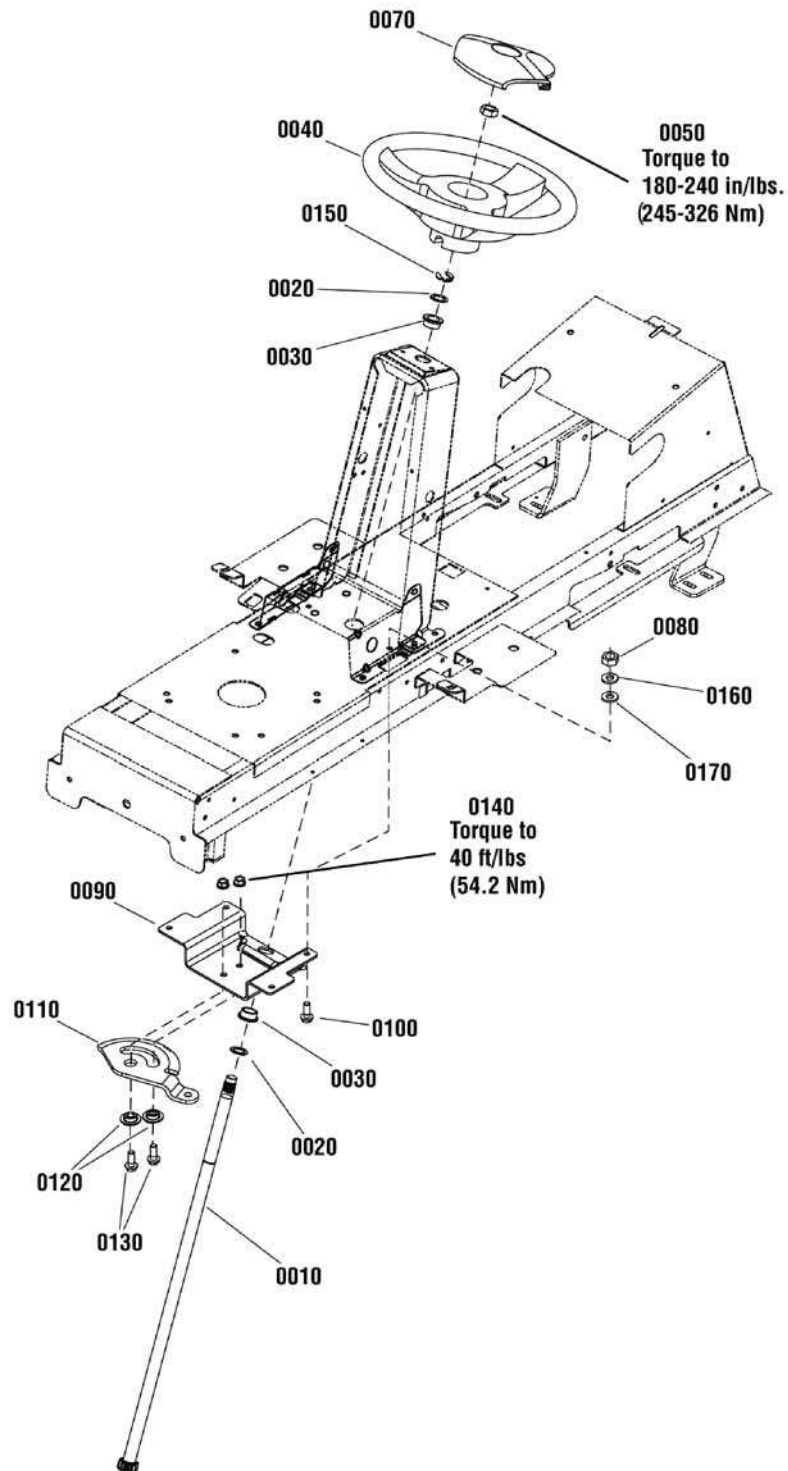

The above parts group applies to the following Mfg. Nos.:

- 2691075 - Regent
- 2691076 - Regent
- 2691077 - Regent
- 2691078 - Regent

Steering Group

REF NO	PART NO.	QTY.	DESCRIPTION
0010	1727813	1	SHAFT, Steering Gear & Spline
0020	1960114	2	WASHER, 3/4
0030	1729665	2	BUSHING
0040	1728069	1	STEERING WHEEL
0050	1960576	1	NUT, Hex Lock 5/8-18
0070	1722319	1	CAP, Steering Wheel, Snapper
0080	1735934	4	NUT, M8
0090	1727940	1	BRACKET, Sector Support
0100	1735870	4	BOLT, M8 x 25
0110	1728027	1	GEAR, Steering , 1/4 Thick, 26 teeth
0120	1728122	2	SPACER, Sector Gear
0130	1934654	2	SCREW, Hex Lock Flange, 3/8-16 x 1
0140	1931211	2	NUT, Hex Flange, 3/8-16
0150	1611710	1	RING, Klipring
0160	1735989	4	WASHER, 8.4
0170	1736000	4	WASHER, 8

Not for
Reproduction

Footnotes

The above parts group applies to the following Mfg. Nos.:

2691075 - Regent
2691076 - Regent
2691077 - Regent
2691078 - Regent

Engine Group - 20HP & 24HP

2990240

NOTE: Unless noted otherwise,
use the standard hardware torque
specification chart.

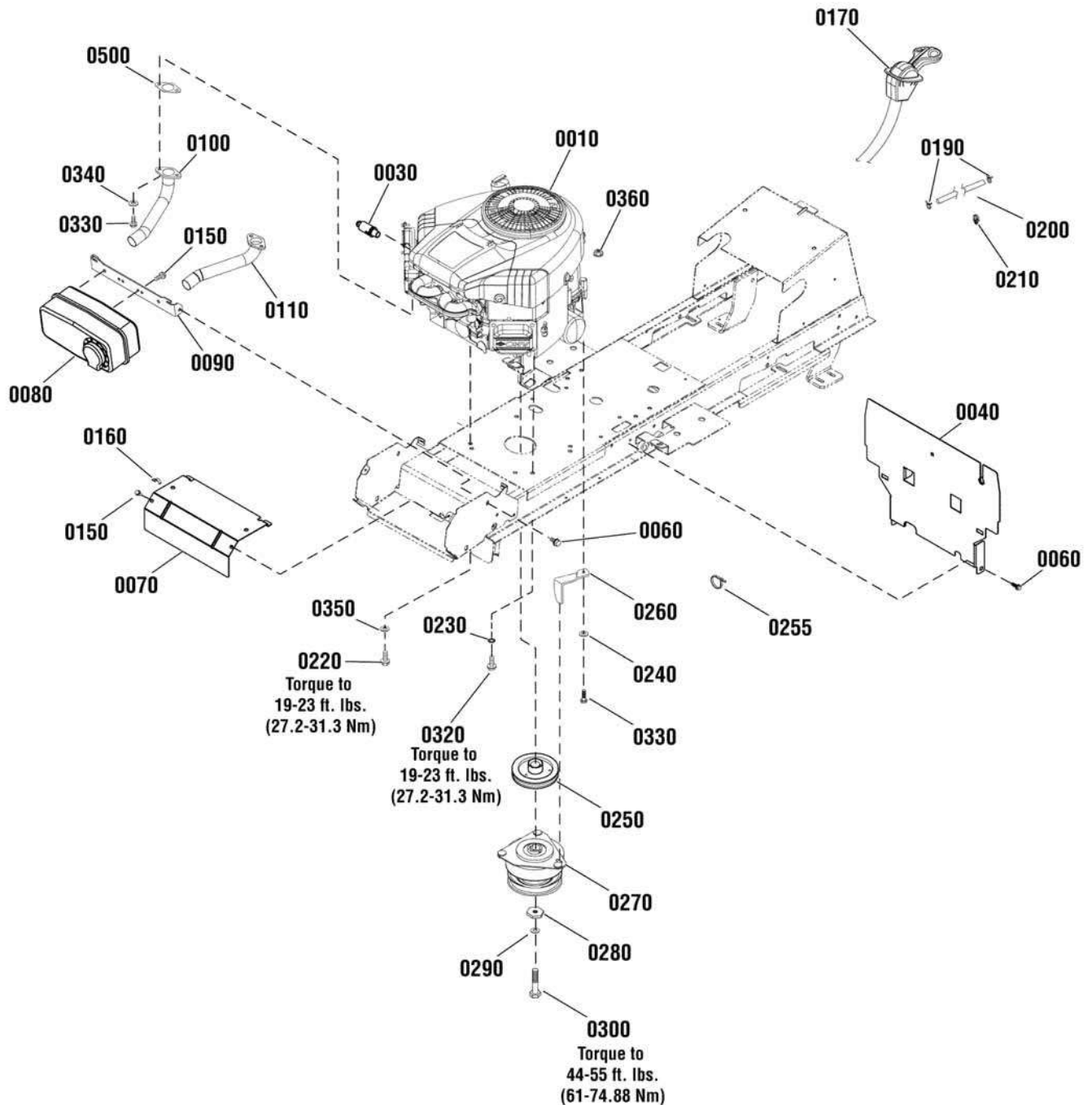

The above parts group applies to the following Mfg. Nos.:

- 2691075 - Regent
- 2691076 - Regent
- 2691077 - Regent
- 2691078 - Regent

Engine Group - 20HP & 24HP

REF NO	PART NO.	QTY.	DESCRIPTION
0010	40G777-0129-B1	1	* ENGINE, 20HP, B&S Twin (Engine Model: 40G777-0129-B1)
0010	44M777-0819-B1	1	* ENGINE, 24HP, B&S Twin (Engine Model: 44M777-0819-B1)
0030	1717473	1	VALVE, Shut-off
0040	1735962	1	HEAT SHIELD
0060	1930601	4	SCREW, Taptite, 5/16-18 x 5/8
0070	1727997	1	HEAT SHIELD
0080	1727994	1	MUFFLER, B&S Twin
0090	1727976	1	BRACKET, Muffler Mount
0100	1727979	1	PIPE, Exhaust, RH
0110	1727980	1	PIPE, Exhaust, LH
0150	1925003	4	SCREW, Taptite, 1/4-20 x 1/2
0160	2834683	1	CLIP, Wire
0170	1734505	1	CONTROL, Throttle (34.75" & 36.5")
0190	1736993	2	CLAMP, Hose UM5008
0200	1735913	1	HOSE, Fuel 1-9920-247
0210	1730268	2	CLIP, Hose
0220	1736994	2	SCREW, M8 x 35
0230	2820427	1	WASHER, Lock, External Tooth, 3/8
0240	1736995	1	WASHER, Flat, 9
0250	1732576	1	PULLEY & HUB ASSEMBLY
0255	1735980	1	TIE
0260	1737421A	1	GUIDE, Belt
0270	1736105	1	CLUTCH, Electric, Ogura
0280	1708264	1	WASHER, Hex 1/2
0290	1918199	1	LOCKWASHER, 7/16
0300	1960649	1	CAPSCREW, Hex Head 7/16-20 x 3-1/2
0320	1736996	2	SCREW, M8 x 45
0330	1936228	4	CAPSCREW, Hex Socket Head, 5/16-18 x 3/4, G8
0340	1917356	4	LOCKWASHER, Spring, 5/16
0350	1736999	4	WASHER, 8.4
0360	1737000	4	NUT, 8
0500	1731214	2	GASKET, Exhaust

Footnotes

Note* To verify your specific engine model, please reference the ID Tag located on your engine. See your local Briggs & Stratton distributor for parts and service.

The above parts group applies to the following Mfg. Nos.:

2691075 - Regent
2691076 - Regent
2691077 - Regent
2691078 - Regent

Controls Group

NOTE: Unless noted otherwise,
use the standard hardware torque
specification chart.

2988009a

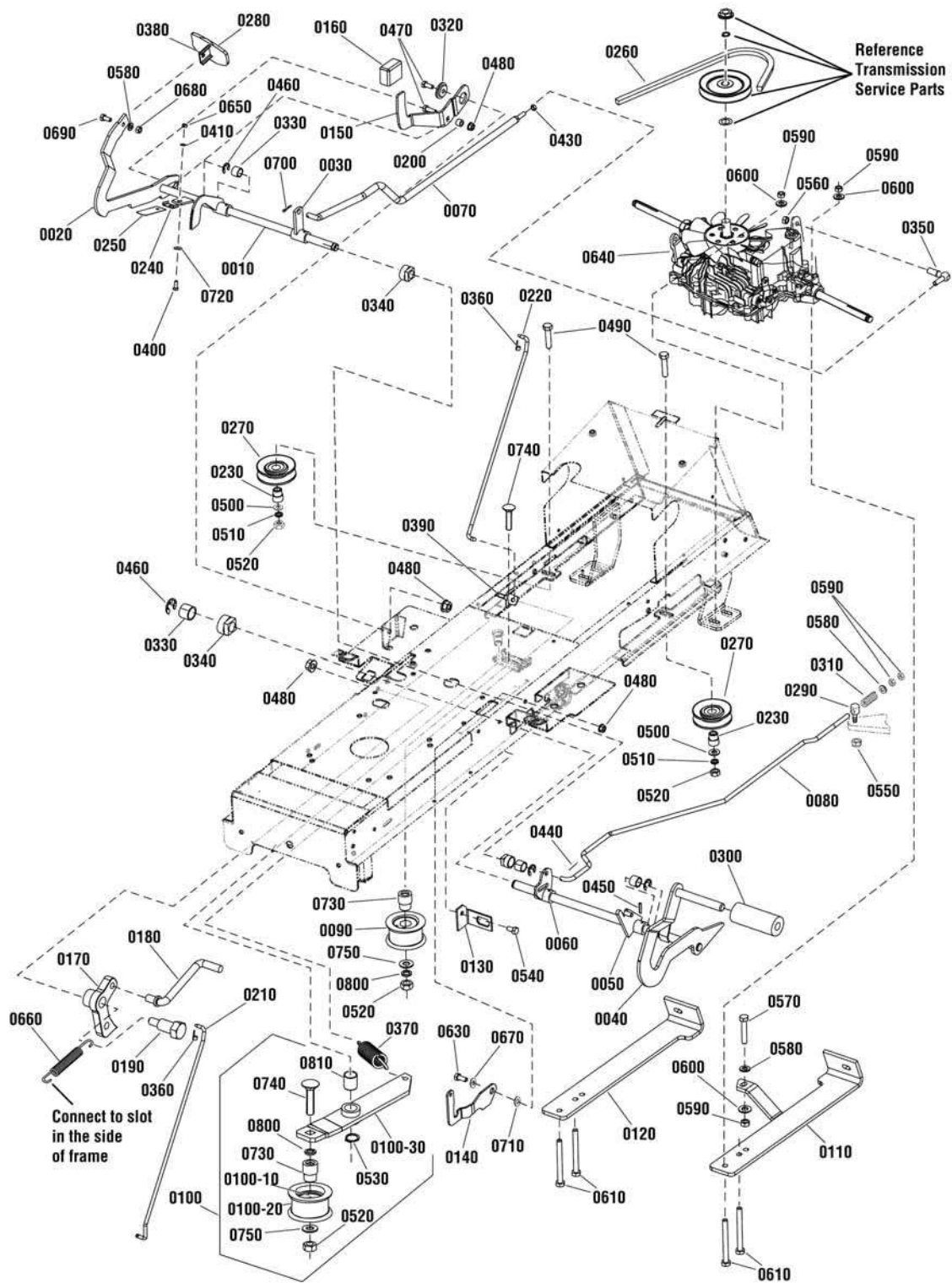

The above parts group applies to the following Mfg. Nos.:

- 2691075 - Regent
- 2691076 - Regent
- 2691077 - Regent
- 2691078 - Regent

Controls Group

REF NO	PART NO.	QTY.	DESCRIPTION
0010	1735940	1	PEDAL, Forward
0020	1735952	1	RATCHET
0030	1735847	1	ARM
0040	1735941	1	PEDAL, Brake
0050	1735918	1	LEVER, Parking Brake
0060	1735917	1	LEVER, Brake
0070	1735959	1	ROD, Traveling
0080	1735957	1	ROD, Brake
0090	1751841	1	PULLEY, Tensioning
0100	1735950	1	PULLEY, Idler (Incl. Ref. Nos. 0100-10, 0100-20, 0100-30, 0520, 0530, 0730, 0740, 0750, 0800 & 0810)
0100-10	1736459	1	BALL BEARING, Pulley, 62032RS
0100-20	1736458	1	PULLEY
0100-30	1736461	1	ARM, Pulley, Tension
0110	1735910	1	HOLDER, Left
0120	1735911	1	HOLDER, Right
0130	1735974	1	SUPPORT, Switch
0140	1735955A	1	LATCH, Brake Lock
0150	1727246	1	PEDAL, Reverse
0160	1727259	1	PAD, Foot Pedal
0170	1727897	1	LATCH, Cruise
0180	1727899	1	ROD, Cruise 5/16 Dia. x 2.83"
0190	1728976	1	BOLT, Shoulder, 5/16-18 x 1-5/8
0200	1728024	1	SPACER, Foot Pedal
0210	1738760	1	ROD, Cruise Latch, 17"
0220	1727267	1	ROD, Parking Brake
0230	1735880	2	BUSHING, 0-9421-418
0240	1736001	1	WASHER, Lock
0250	1735972	1	SPRING, Flat 0-9740-221
0260	1752054	1	V-BELT, Li, BBT, 13 x 2580
0270	1735949	2	PULLEY, Compensa C-00237/1
0280	1735942	1	PEDAL, Forward Rubber
0290	1735853	1	BOLT, 0-9016-447
0300	1727261	1	PEDAL, Brake Pad
0310	1735968	1	SPRING, TLZ 250.150.0530 Yellow
0320	1727935	1	SPACER, Pivot
0330	1735896	4	DISTANCE, Pedal 0-9521-288
0340	1735881	4	BUSHING, 0-9462-202
0350	1735850	1	BALL JOINT, CS 13 DIN 71802 M8, Silver
0360	1728111	2	CLIP, Linkage .250 dia
0370	1735969	1	SPRING, TZ 2x14x62, Yellow
0380	1735943	1	PEDAL, Forward, Top
0390	1735875	1	BOLT, Eye M6x80 BN1006
0400	1735866	1	BOLT, M6 x 16
0410	1735998	2	WASHER, 6.4

Footnotes

The above parts group applies to the following Mfg. Nos.:

2691075 - Regent
2691076 - Regent
2691077 - Regent
2691078 - Regent

Controls Group

NOTE: Unless noted otherwise,
use the standard hardware torque
specification chart.

2988009a

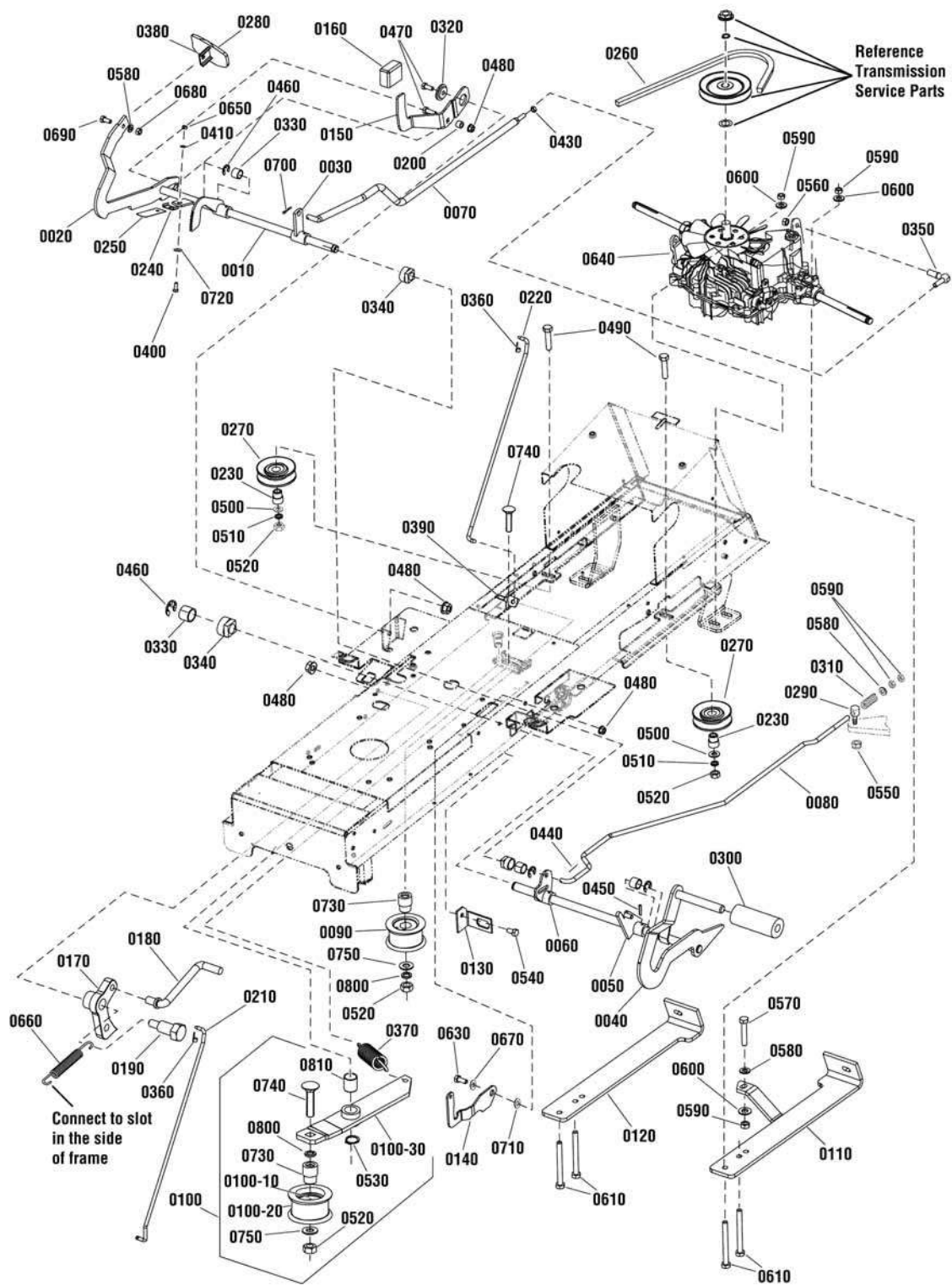

The above parts group applies to the following Mfg. Nos.:

- 2691075 - Regent
- 2691076 - Regent
- 2691077 - Regent
- 2691078 - Regent

Controls Group

REF NO	PART NO.	QTY.	DESCRIPTION
0430	1735936	1	NUT, M8
0440	1735963	2	SPINDLE, 2 x 20
0450	1735946	4	PIN, Flex. 5 x 25
0460	1735920	4	LOCK RING, 12
0470	1960223	2	BOLT, Carriage, 5/16-18 x 1-1/4
0480	1931277	4	NUT, Hex Flange, 5/16-18
0490	1735855	2	BOLT, M10 x 40
0500	1735990	2	WASHER, 10.5
0510	1735991	3	WASHER, 10.0
0520	1735925	3	NUT, M10
0530	1735921	1	LOCK RING, 16
0540	1930601	1	SCREW, Tap, 5/16-18 x 5/8
0550	1735924	1	NUT, M10
0560	1735938	1	NUT, M8 DIN 6923 8 Yellow, Tooth
0570	1735873	1	BOLT, M8 x 45
0580	1735989	7	WASHER, 8.4
0590	1735934	7	NUT, M8
0600	1736000	5	WASHER, 8
0610	1735874	4	BOLT, M8 x 75
0630	1729576	1	BOLT, Shoulder 5/16-18 x 1-3/16
0640	1735476	1	TRANSMISSION, Tuff Torq, K-46CW
0650	1735933	3	NUT, M6
0660	2159181	1	SPRING
0670	1735994	3	WASHER, 14 x 26/0.2
0680	1735935	1	NUT, M8
0690	1751843	1	BOLT, M8 x 20
0700	1735964	1	SPINDLE, 3.2 x 25
0710	1739135	1	WASHER, 16 x 22 x 1
0720	1751842	1	WASHER, 6
0730	1751840	2	BUSHING, Pulley, Tension
0740	1751844	1	BOLT, M10 x 45
0750	1751845	2	WASHER, 11
0800	1736456	2	LOCK RING, 40
0810	1736462	1	BEARING, Slide

Footnotes

The above parts group applies to the following Mfg. Nos.:

2691075 - Regent
2691076 - Regent
2691077 - Regent
2691078 - Regent

Electrical Group

NOTE: Unless noted otherwise, use the standard hardware torque specification chart.

2988014a

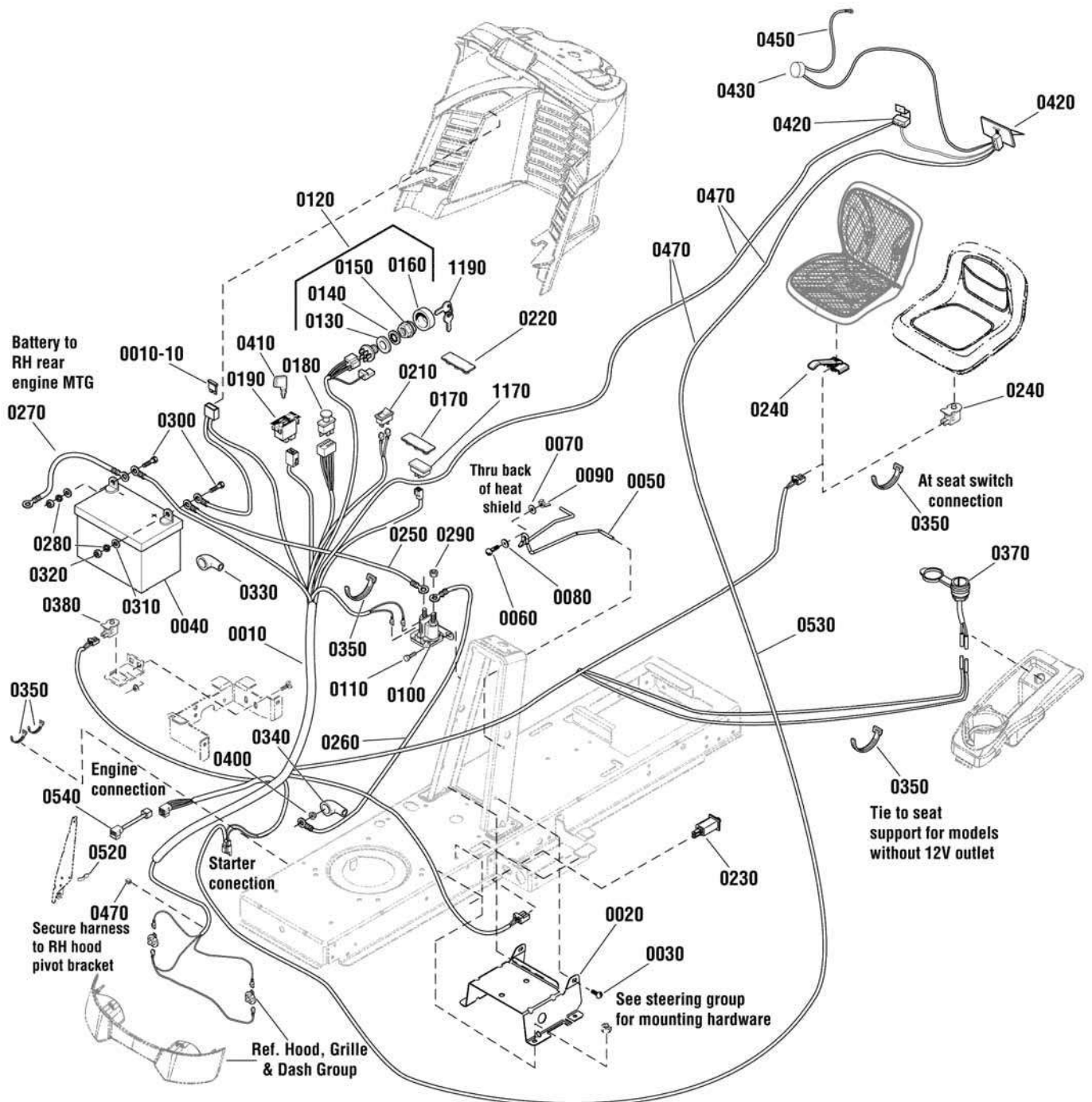

The above parts group applies to the following Mfg. Nos.:

- 2691075 - Regent
- 2691076 - Regent
- 2691077 - Regent
- 2691078 - Regent

Electrical Group

REF NO	PART NO.	QTY.	DESCRIPTION
0010	1736864	1	HARNESSES, Main
0010-10	1731957	1	FUSE
0020	1727282	1	SUPPORT, Battery
0030	1930601	4	SCREW, Hex Washer Head, Taptite, 5/16-18 x 5/8
0040	-----	1	BATTERY, 12V 230 CCA DRY
0050	1730007	1	HOLD DOWN, Battery
0060	1931318	1	BOLT, Carriage, 1/4-20 x 7/8
0070	1960353	1	WASHER, Flat .25
0080	1960518	1	PUSHNUT, 1/4
0090	1920397	1	NUT, 1/4 ESNA
0100	1728963	1	SOLENOID, 12V
0110	1925003	2	SCREW, Hex Washer Head, TAPTITE, 1/4-20 x 1/2
0120	1716061	1	SWITCH ASSEMBLY, Ignition (Includes Ref. Nos. 0130, 0140, 0150 & 0160)
0130	2101025	1	WASHER, 5/8
0140	1960547	1	WASHER, Lock, Int. Tooth .62
0150	1717549	1	NUT, Hex Flange, 5/8, IGN Switch
0160	1717550	1	COVER, Ignition Switch
0170	1729993	1	PLUG, Hour Meter (Use on 20HP Models)
0180	1722887	1	SWITCH, PTO
0190	1726556	1	SWITCH, RMO Module Only
0210	1716951	1	SWITCH, Head lights
0220	1722611	1	PLUG
0230	1732006	1	SWITCH, Push (Foot Pedal)
0240	1732005	1	SWITCH, Push NC (Seat) (Use with Standard Seat)
0240	1738015	1	SWITCH, Seat, Paddle (Use with Mesh Seat)
0250	1716549	1	CABLE, #6 10.0 Lg Red
0260	1721830	1	CABLE, #6 25.0 Lg Red
0270	1713163	1	CABLE, #6 20.0 Lg Black
0280	2816964	2	LOCKWASHER, Spring 1/4
0290	2860750	2	NUT, Hex KEPS Lock, 5/16-24
0300	2823341	2	CAPSCREW, Hex, 1/4-20 x 3/4
0310	2821319	2	WASHER, Flat, 1/4
0320	2816622	2	NUT, Hex, 1/4-20
0330	1677296	1	BOOT, Insulator, Battery
0340	1713535	1	BOOT, Insulator, Red
0350	1735980	5	TIE, Self Lock
0370	7073090	1	12V AUX. PLUG, With Cover
0380	1732004	1	SWITCH, NO (RMO)
0400	1960294	1	NUT, Flange, Whiz, 1/4-20
0410	1726557	1	KEY, RMO Module
0420	1735922	2	MICROSWITCH, MKH 12 D13 S1
0430	1735852	1	BEEPER, PF 27 A 29 EP/
0450	1736002	1	WIRE, 9-8316-615
0470	1735882	7	CABLE, Clip WSBH 1-0-1

Footnotes

The above parts group applies to the following Mfg. Nos.:

2691075 - Regent
2691076 - Regent
2691077 - Regent
2691078 - Regent

Electrical Group

NOTE: Unless noted otherwise, use the standard hardware torque specification chart.

2988014a

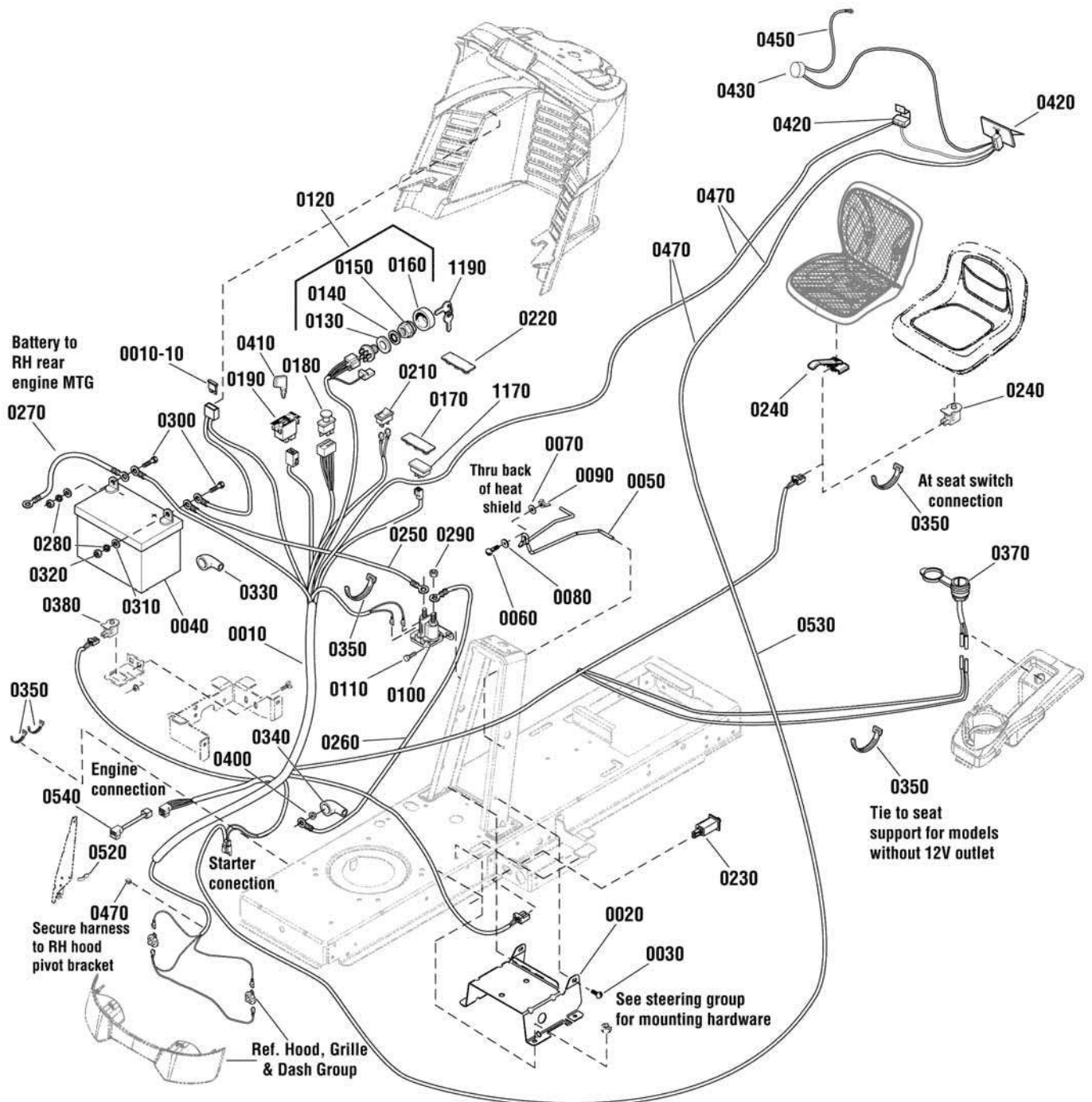

The above parts group applies to the following Mfg. Nos.:

- 2691075 - Regent
- 2691076 - Regent
- 2691077 - Regent
- 2691078 - Regent

Electrical Group

REF NO	PART NO.	QTY.	DESCRIPTION
0520	2834683	1	CLIP, Speed Wire
0530	1736417	1	CABLE, Harness
0540	1736418	1	CABLE, Adapter
1170	1731185	1	HOUR METER (Use on 24HP Models)
1190	1717163	1	KEY, Ignition (Set of 2)

Not for
Reproduction

Footnotes

The above parts group applies to the following Mfg. Nos.:

2691075 - Regent
2691076 - Regent
2691077 - Regent
2691078 - Regent

Hood, Grille & Dash Group

NOTE: Unless noted otherwise,
use the standard hardware torque
specification chart.

2988883a

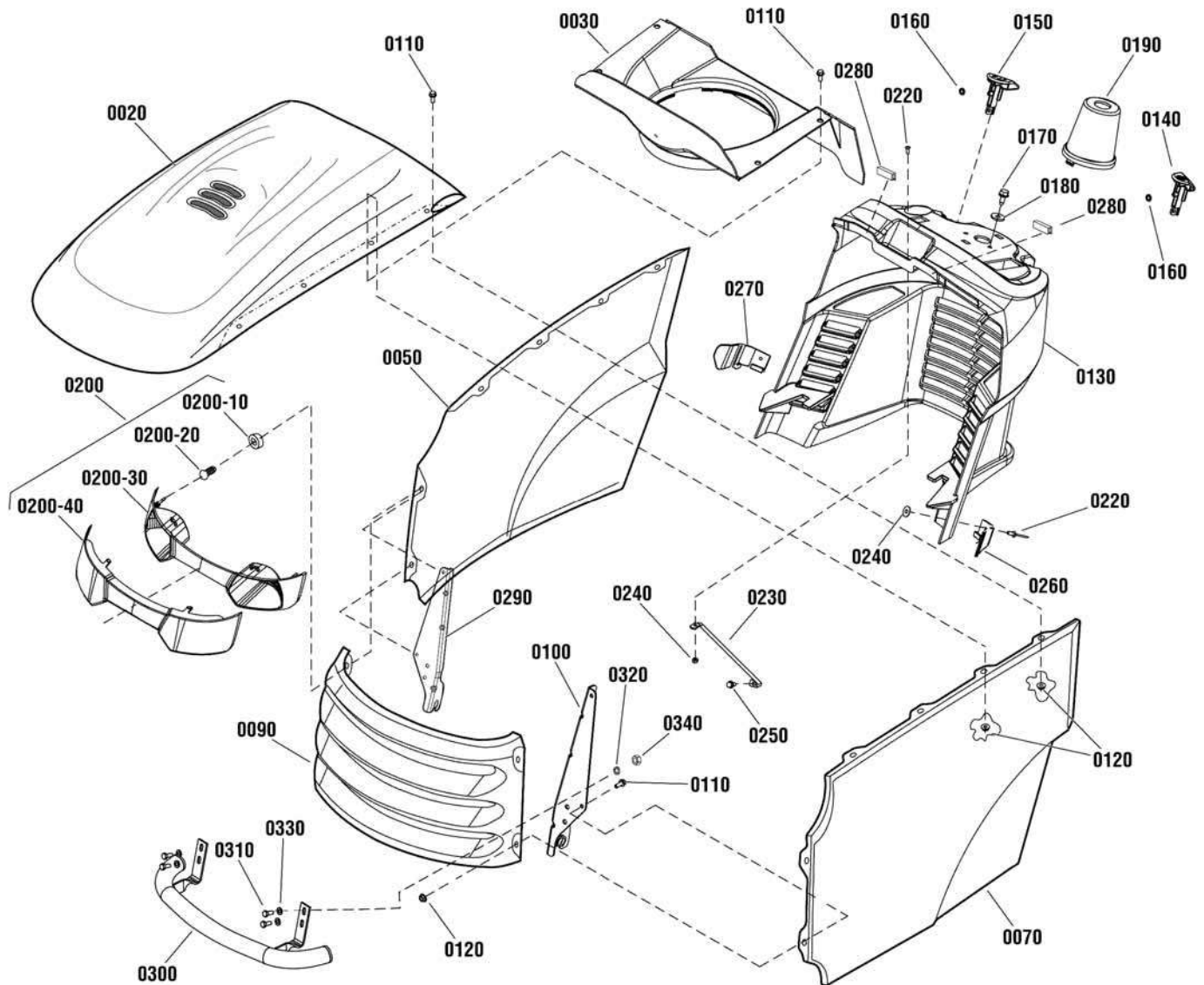

The above parts group applies to the following Mfg. Nos.:

- 2691075 - Regent
- 2691076 - Regent
- 2691077 - Regent
- 2691078 - Regent

Hood, Grille & Dash Group

REF NO	PART NO.	QTY.	DESCRIPTION
0020	1722110C	1	HOOD, With Scoop
0030	7102326	1	DUCT, Air Inlet
0050	1728029C	1	PANEL, Hood, Right
0070	1728030C	1	PANEL, Hood, Left
0090	1727297C	1	GRILLE
0100	1727279	1	HINGE, Hood, Left
0110	1960295	12	CAPSCREW, Hex Lock, 1/4-20 x 5/8
0120	1930641	12	NUT, Hex Flange Lock, 1/4-20
0130	1727293	1	DASHBOARD
0140	1728089	1	KNOB, Brake Lock
0150	1728090	1	KNOB, Cruise Lock
0160	1960518	2	NUT, Push Pal, 1/4
0170	1664847	2	CAPSCREW, Hex Taptite, 5/16-18 x 3/4
0180	1919381	2	WASHER, 5/16
0190	1727999	1	COVER, Steering Shaft
0200	1727296	1	HEADLIGHT ASSEMBLY
0200-10	1723451	2	SOCKET ASSEMBLY (Included in Ref. 0200)
0200-20	1677371	2	BULB, 1141-12V 21CP (Included in Ref. 0200)
0200-30	1728973	1	REFLECTOR, Headlight (Included in Ref. 0200)
0200-40	1728974	1	LENS, Headlight (Included in Ref. 0200)
0220	1960392	3	SCREW, Phillips Head
0230	1723123	1	ROD, Dash Support
0240	1933896	3	NUT, Flange
0250	1925003	1	SCREW, Self Tap
0260	1732030	1	GUIDE, Hood, Left
0270	1732031	1	GUIDE, Hood, Right
0280	1735878	2	BRAID, Steel-Insert 0-9634-219
0290	1727280	1	HINGE, Hood, Right
0300	1735879	1	BUMPER, Front
0310	1735868	4	BOLT, M8 x 20
0320	1735989	4	WASHER, 8.4
0330	1736000	4	WASHER, 8
0340	1735934	4	NUT, M8

Footnotes

The above parts group applies to the following Mfg. Nos.:

2691075 - Regent
2691076 - Regent
2691077 - Regent
2691078 - Regent

Seat Deck & Fuel Group

NOTE: Unless noted otherwise,
use the standard hardware torque
specification chart.

2988773a

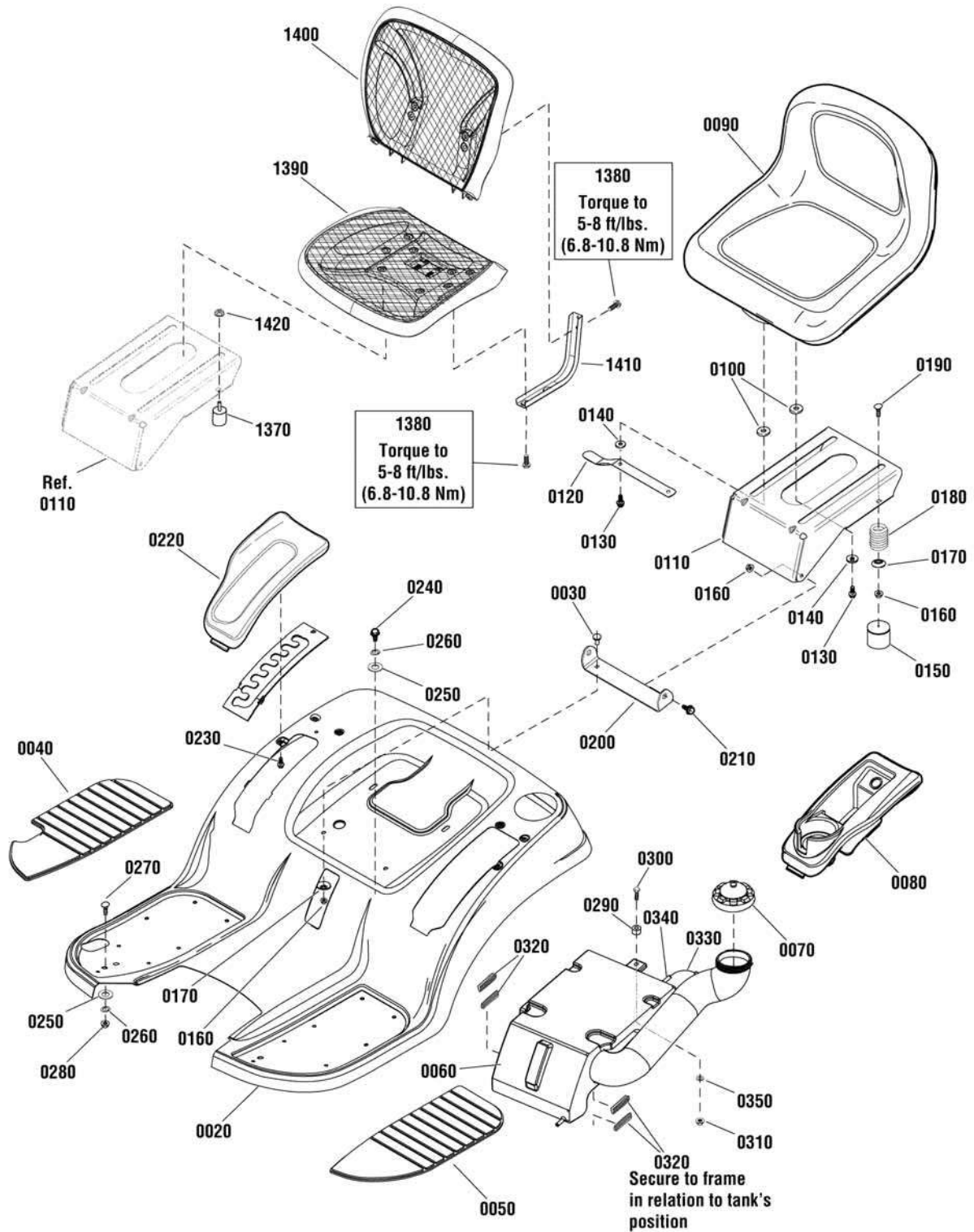

The above parts group applies to the following Mfg. Nos.:

- 2691075 - Regent
- 2691076 - Regent
- 2691077 - Regent
- 2691078 - Regent

Seat Deck & Fuel Group

REF NO	PART NO.	QTY.	DESCRIPTION
0020	1735259C	1	DECK, Seat With Foot Rests
0030	1931333	2	BOLT, Carriage, 5/16-18 x 3/4
0040	1728007	1	PAD, Footrest, Right
0050	1728006	1	PAD, Footrest, Left
0060	1735976	1	TANK, Fuel 9-2770-244
0070	1715917	1	CAP, Fuel
0080	1739535	1	POD, Cup Holder, Left
0090	1754213	1	SEAT
0100	1731300	4	SPACER
0110	1727265	1	SUPPORT, Seat
0120	1727268	1	LATCH, Seat
0130	1960667	4	SCREW, Flange 5/16-18 x 1
0140	1919381	4	WASHER, 5/16
0150	1704724	2	COVER, Spring
0160	1960686	6	NUT, Hex Flange, 5/16-18 (Qty 4 used with Mesh Seat)
0170	1709256	4	WASHER, Spring (Qty 2 used with Mesh Seat)
0180	1704728	2	SPRING, Compression (Use with Standard Seat)
0190	1960282	2	BOLT, Carriage, 5/16-18 x 3/4 (Use with Standard Seat)
0200	1727266	1	PIVOT, Seat
0210	1729576	2	BOLT, Shoulder, 5/16-18 x 1/8
0220	1739537	1	POD, Lift, Right
0230	1960536	6	SCREW, Hex, 1/4-1/2
0240	1735854	2	BOLT, M8 x 16
0250	1735989	4	WASHER, 8.4
0260	1736000	4	WASHER, 8
0270	1735869	2	BOLT, M8 x 20
0280	1735937	2	NUT, M8
0290	1735894	1	DISTANCE, Lift 0-9521-289
0300	1735867	1	BOLT, M6 x 30
0310	1735932	1	NUT, M6
0320	1735878	4	BRAID, Steel Insert 0-9634-219
0330	1735914	1	HOSE, Air Escape 1-9920-248
0340	1736993	2	CLIP, UM 5008
0350	1735999	1	WASHER, 6.6
1370	1739934	2	BUMPER, Rubber (Use with Mesh Seat)
1380	1930591	8	SCREW, Hex Flange, Whiz Lock, 5/16-18 x 3/4 (Use with Mesh Seat)
1390	1738013	1	SEAT, Mesh, Bottom
1400	1738014	1	SEAT, Mesh, Back
1410	1737848A	2	SUPPORT, Mesh Seat (Use with Mesh Seat)
1420	1931277	2	NUT, Hex Flange, 5/16-18 (Use with Mesh Seat)

Footnotes

The above parts group applies to the following Mfg. Nos.:

2691075 - Regent
 2691076 - Regent
 2691077 - Regent
 2691078 - Regent

Mulching Flap Group

NOTE: Unless noted otherwise,
use the standard hardware torque
specification chart.

2988026a

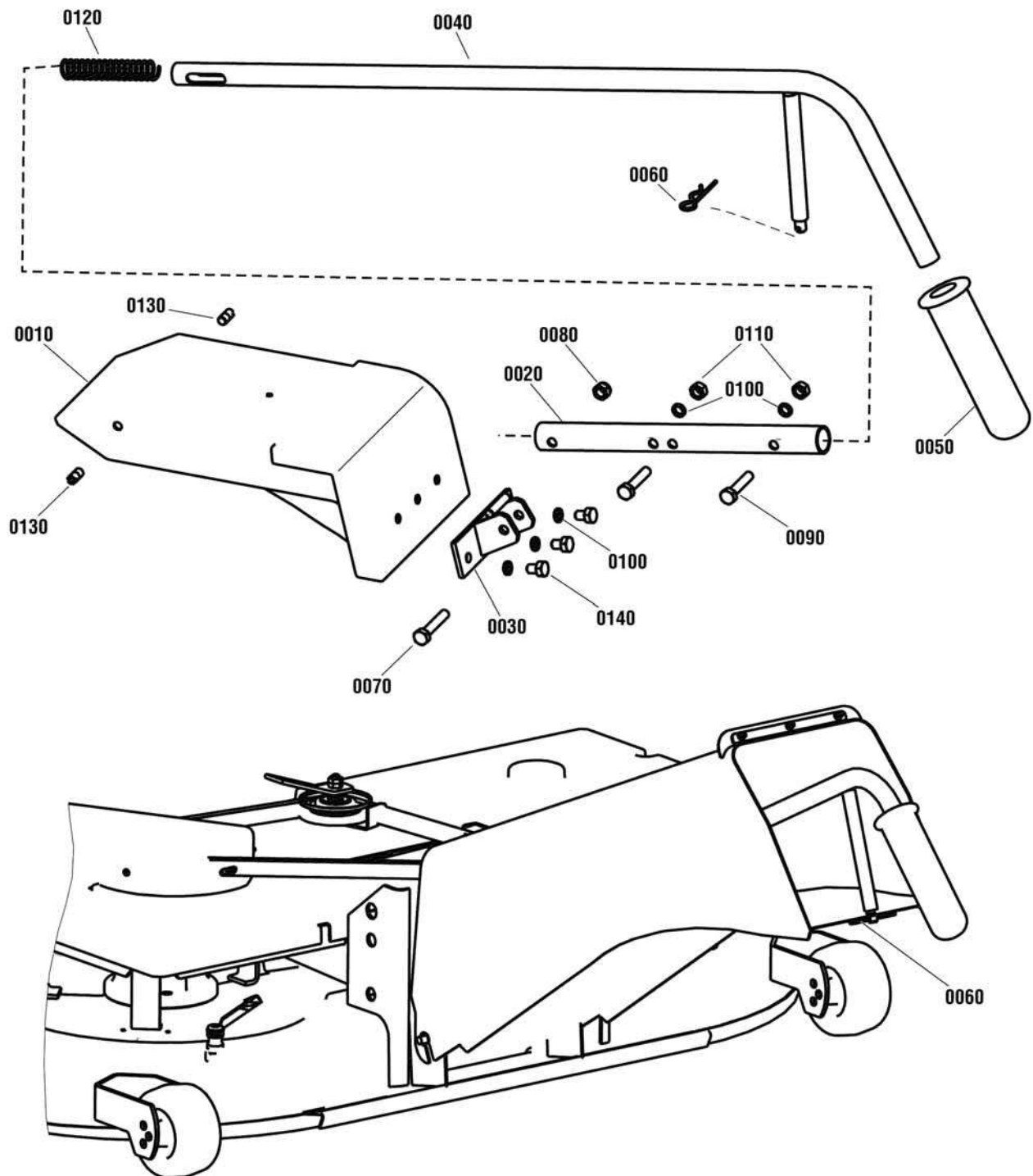

The above parts group applies to the following Mfg. Nos.:

2691077 - Regent

2691078 - Regent

Mulching Flap Group

REF NO	PART NO.	QTY.	DESCRIPTION
0010	1736134	1	FLANGE, Mowing
0020	1736133	1	TUBE
0030	1736132	1	HOLDER
0040	1736131	1	FULL TUBE
0050	1736130	1	HANDLE
0060	1736129	1	SPLIT PIN
0070	1736128	1	SCREW, M8 x 45
0080	1736127	1	NUT, M8
0090	1736126	2	SCREW, M8 x 35
0100	1736125	5	WASHER, 8
0110	1736124	2	NUT, M8
0120	1736123	1	SPRING
0130	1736122	2	CASING
0140	1736121	3	SCREW, M8 x 12

Not for
Reproduction

Footnotes

The above parts group applies to the following Mfg. Nos.:

2691077 - Regent

2691078 - Regent

Lift Group - Manual

NOTE: Unless noted otherwise, use the standard hardware torque specification chart.

2988020a

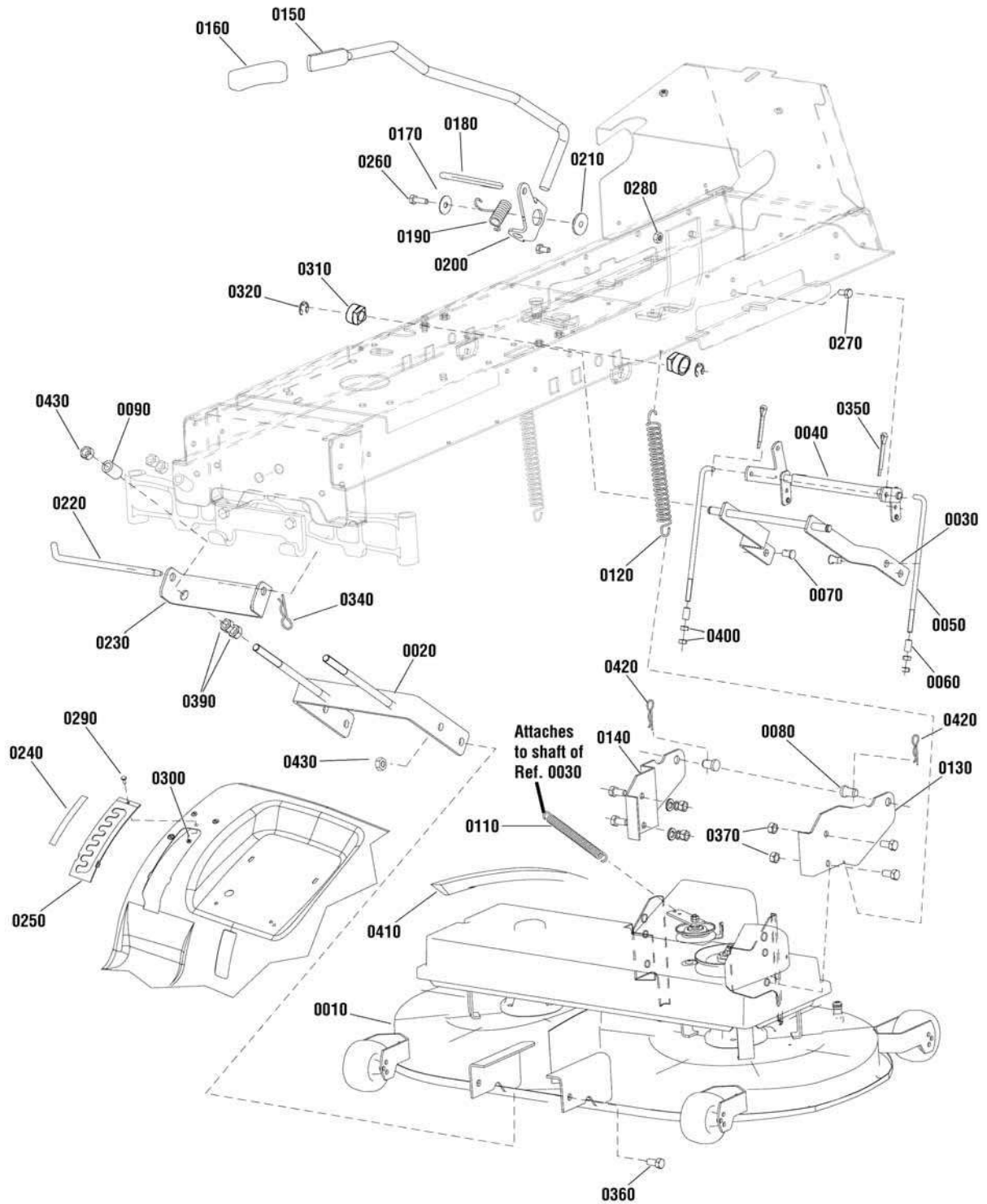

The above parts group applies to the following Mfg. Nos.:

- 2691075 - Regent
- 2691076 - Regent
- 2691077 - Regent
- 2691078 - Regent

Lift Group - Manual

REF NO	PART NO.	QTY.	DESCRIPTION
0010	1735923	1	MOWING MECHANISM
0020	1735902	1	HINGE, Front
0030	1735848	1	ARM, Lift
0040	1735958	1	ROD, Lift
0050	1735979	2	TIE ROD, Lift 0-8040-311
0060	1735893	2	DISTANCE, Lift 0-9521-289
0070	1735945	2	PIN, 0-9016-463
0080	1735947	2	PIN, Mowing 1-9310-417
0090	1735895	2	DISTANCE, Lift Hitch 0-9521-290
0110	1735966	1	SPRING, 0-9746-460
0120	1735967	2	SPRING, 0-9746-483
0130	1735898	1	HANDLE, Extend, Left
0140	1735899	1	HANDLE, Extend, Right
0150	1735956	1	ROD, Lift
0160	1722302	1	GRIP, Black
0170	1960044	1	WASHER, 5/16
0180	1727954	1	ROD, Lift 3/8 dia
0190	1729652	1	SPRING, Torsion
0200	1728990	1	CLEVIS, Lift
0210	1727935	1	SPACER, Pivot
0220	1731414	1	PIN, Hitch
0230	1730221A	1	HANGER, Front
0240	1730264	1	DECAL, Height of Cut
0250	1727985	1	QUADRANT, Lift Height
0260	1921333	1	CAPSCREW, Hex Head, 5/16-18 x 1
0270	1930601	2	CAPSCREW, Hex Head, 5/16-18 x 5/8
0280	1931277	1	NUT, Hex Flange Lock, 5/16-18
0290	1960252	1	BOLT, Carriage, 1/4-20 x 5/8
0300	1930641	1	NUT, Hex Flange Whiz, 1/4-20
0310	1735881	2	BUSHING, 0-9462-202
0320	1735920	2	LOCK RING, 12
0340	2176012	1	CLIP, Pin Safety
0350	1735964	4	SPINDLE
0360	1751847	6	BOLT, M12 x 30
0370	1751848	4	NUT, Flange Lock, M12
0390	1735927	8	NUT, M12
0400	1735925	4	NUT, M10
0410	1735986	1	V-BELT, Li, 17 x 1200
0420	1737015	2	SPRING PIN
0430	1735796	4	NUT, M12

Footnotes

The above parts group applies to the following Mfg. Nos.:

2691075 - Regent
2691076 - Regent
2691077 - Regent
2691078 - Regent

Wheels & Tires Group

2988024a

NOTE: Unless noted otherwise,
use the standard hardware torque
specification chart.

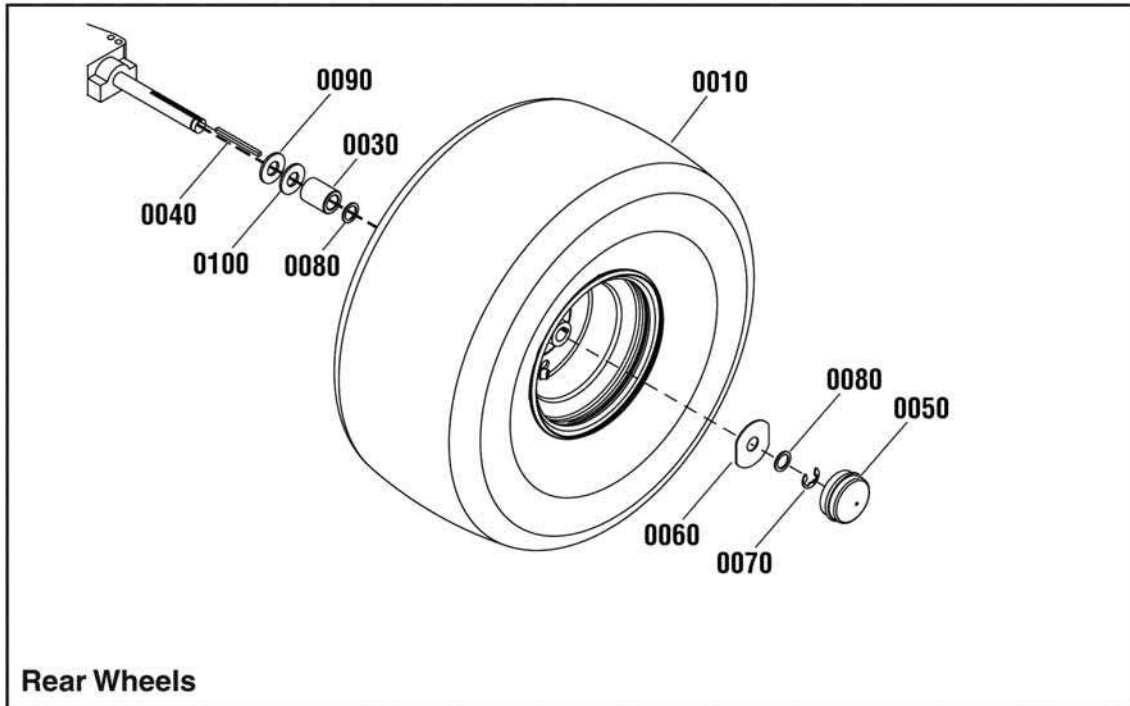
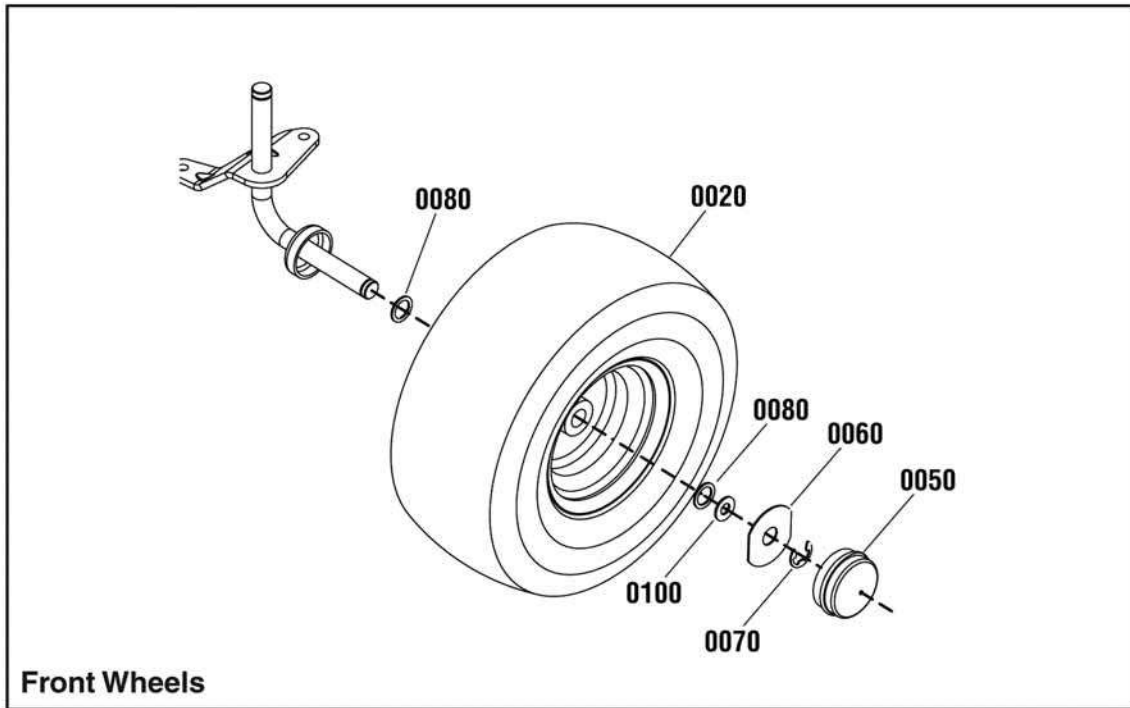

The above parts group applies to the following Mfg. Nos.:

- 2691075 - Regent
- 2691076 - Regent
- 2691077 - Regent
- 2691078 - Regent

Wheels & Tires Group

REF NO	PART NO.	QTY.	DESCRIPTION
0010	1752972	2	WHEEL & TIRE ASSEMBLY, Rear, 7L x 8H2
0020	1752971	2	WHEEL & TIRE ASSEMBLY, Front, 4.5A x 6H2
0030	1730181	2	SPACER, Axle, Rear PM Hunter
0040	1713409	2	KEY, Parallel
0050	1722676	4	HUB CAP, 2.361 D, Grey Poly 1.3H, VIPER
0060	1722717	4	WASHER, Special, 2-1/2
0070	2827794	4	RING, Klipring, EXT For .75 Dia Shaft blk
0080	2860183	8	WASHER, 3/4
0090	2860202	2	WASHER, 3/4
0100	1735988	8	WASHER

Not for
Reproduction

Footnotes

The above parts group applies to the following Mfg. Nos.:

2691075 - Regent
2691076 - Regent
2691077 - Regent
2691078 - Regent

Decals Group

2990244

NOTE: Unless noted otherwise,
use the standard hardware torque
specification chart.

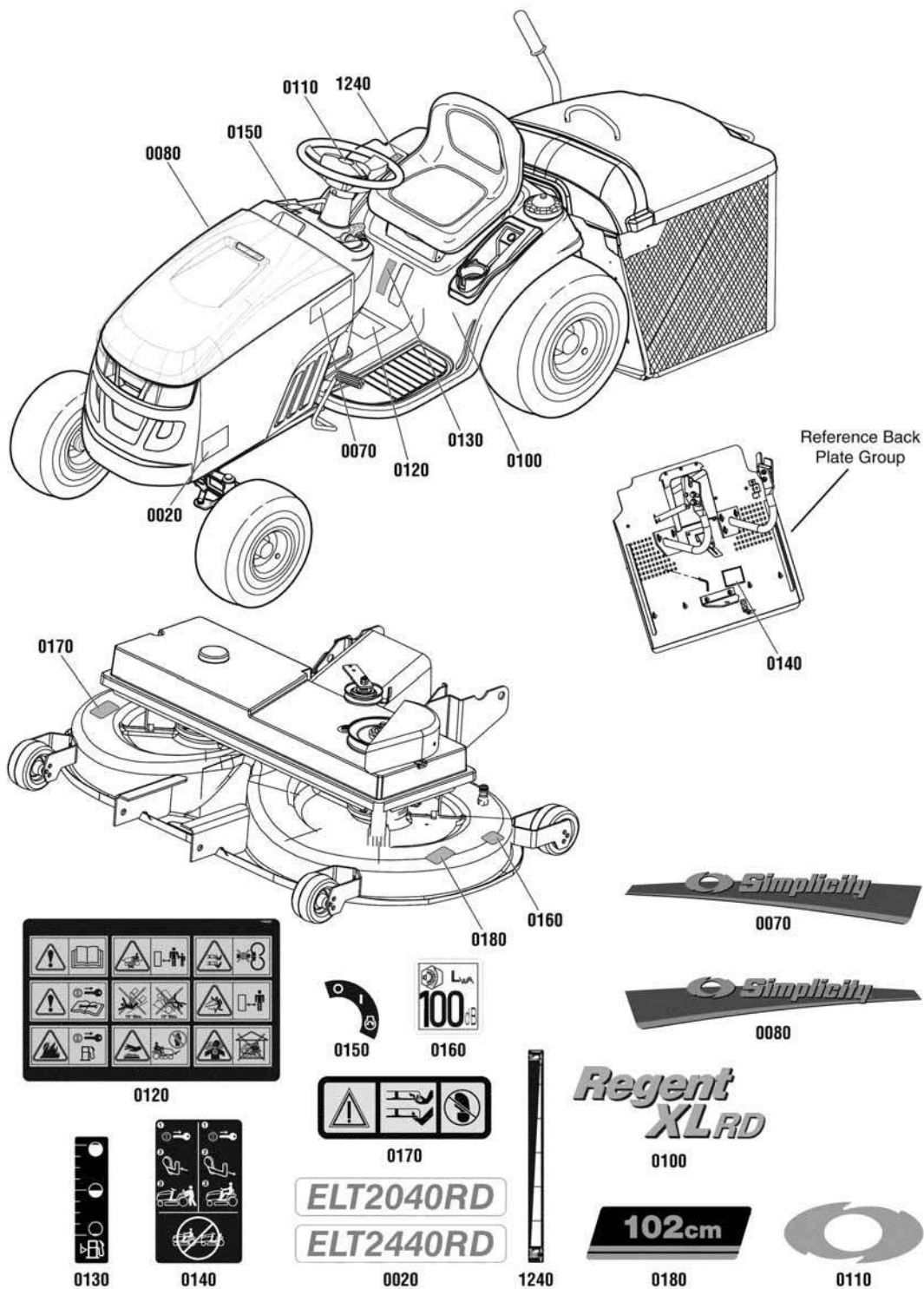

The above parts group applies to the following Mfg. Nos.:

- 2691075 - Regent
- 2691076 - Regent
- 2691077 - Regent
- 2691078 - Regent

Decals Group

REF NO	PART NO.	QTY.	DESCRIPTION
0020	1753580	2	DECAL, Model, ELT2040RD
0020	1753581	2	DECAL, Model, ELT2440RD
0070	1731390	1	DECAL, Logo, Stripe, LH
0080	1731391	1	DECAL, Logo, Stripe, RH
0100	1735542	1	DECAL, XL RD
0110	1731418	1	DECAL, Logo, Steering Wheel
0120	1734027	1	DECAL, Tunnel
0130	1735889	1	DECAL, Fuel Level
0140	1735265	1	DECAL, Trans/Tow Release Lever
0150	1722806	1	DECAL, Ignition Switch White/Blk
0160	1735891	1	DECAL, Noise
0170	1735890	2	DECAL, Safety
0180	1737187	1	DECAL, Deck Width
1240	1730264	1	DECAL, Mower Height

Not for
Reproduction

Footnotes

The above parts group applies to the following Mfg. Nos.:

2691075 - Regent
2691076 - Regent
2691077 - Regent
2691078 - Regent

Back Plate Group

NOTE: Unless noted otherwise,
use the standard hardware torque
specification chart.

2988766a

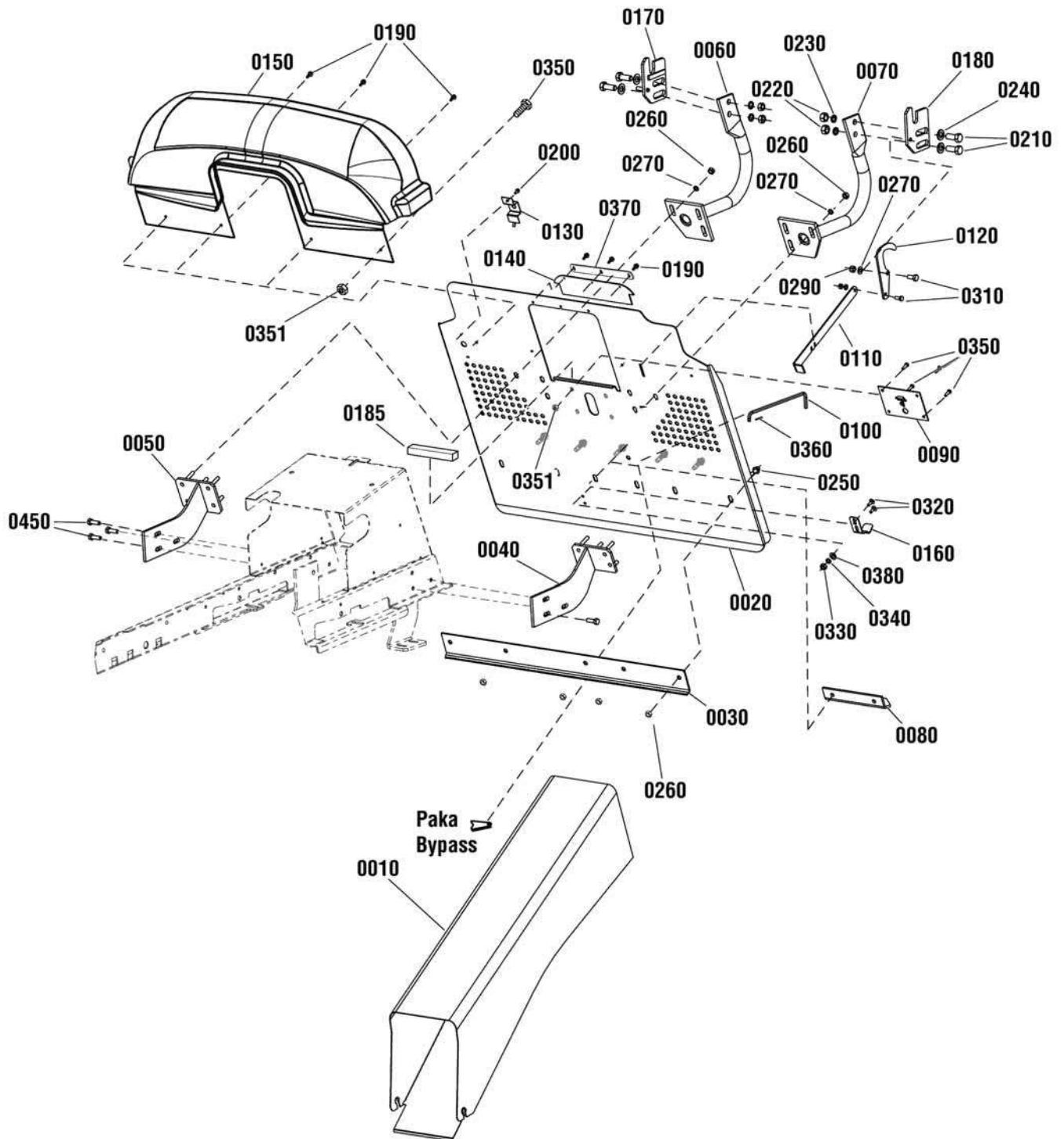

The above parts group applies to the following Mfg. Nos.:

- 2691075 - Regent
- 2691076 - Regent
- 2691077 - Regent
- 2691078 - Regent

Back Plate Group

REF NO	PART NO.	QTY.	DESCRIPTION
0010	1735985	1	TUNNEL
0020	1735849	1	BACKPLATE
0030	1735876	1	BRACE
0040	1735906	1	HOLDER, Back Plate, L.H.
0050	1735907	1	HOLDER, Back Plate, R.H.
0060	1735908	1	HOLDER, Collector, R.H.
0070	1735909	1	HOLDER, Collector, L.H.
0080	1735903	1	HITCH
0090	1735975	1	SWITCH, Full Collector
0100	1735977	1	TIE ROD, Bypass
0110	1735978	1	TIE ROD, Latch
0120	1735915	1	LATCH
0130	1735887	1	COVER, Switch
0140	1735939	1	PAD, Rubber
0150	1735983	1	TRANSITION PART
0160	1735970	1	SPRING, Collector Lock
0170	1735904	1	HOLDER, Adjustable, R.H.
0180	1735905	1	HOLDER, Adjustable, L.H.
0185	1736998	1	RUBBER EDGE
0190	1735961	6	CAPSCREW, Self Tap, 5,5 x 19
0200	1735960	1	CAPSCREW, Self Tap, 4.2 x 9.5
0210	1735857	4	BOLT, M12 x 30
0220	1735927	4	NUT, M12
0230	1735993	4	WASHER, 13
0240	1735992	4	WASHER, 12
0250	1735871	6	BOLT, M8 x 25 DIN 6921 8.8
0260	1751829	12	NUT, Flange Lock, M8
0270	1735989	14	WASHER, 8.4
0290	1735935	2	NUT, M8
0310	1735868	2	CAPSCREW, M8 x 40
0320	1735860	2	BOLT, M5 x 16
0330	1735930	2	NUT, M5
0340	1735997	2	WASHER, 5.3
0350	1735861	5	BOLT, M5 x 16
0351	1735931	5	NUT, M5
0360	1735963	1	SPINDLE
0370	1739133	1	PAD, Steel
0380	1739134	2	WASHER, 5.3
0450	1930601	6	SCREW, Hex Washer Head, Taptit, 5/16-18 x 5/8

Footnotes

The above parts group applies to the following Mfg. Nos.:

2691075 - Regent
2691076 - Regent
2691077 - Regent
2691078 - Regent

Collector Group

NOTE: Unless noted otherwise,
use the standard hardware torque
specification chart.

2988007a

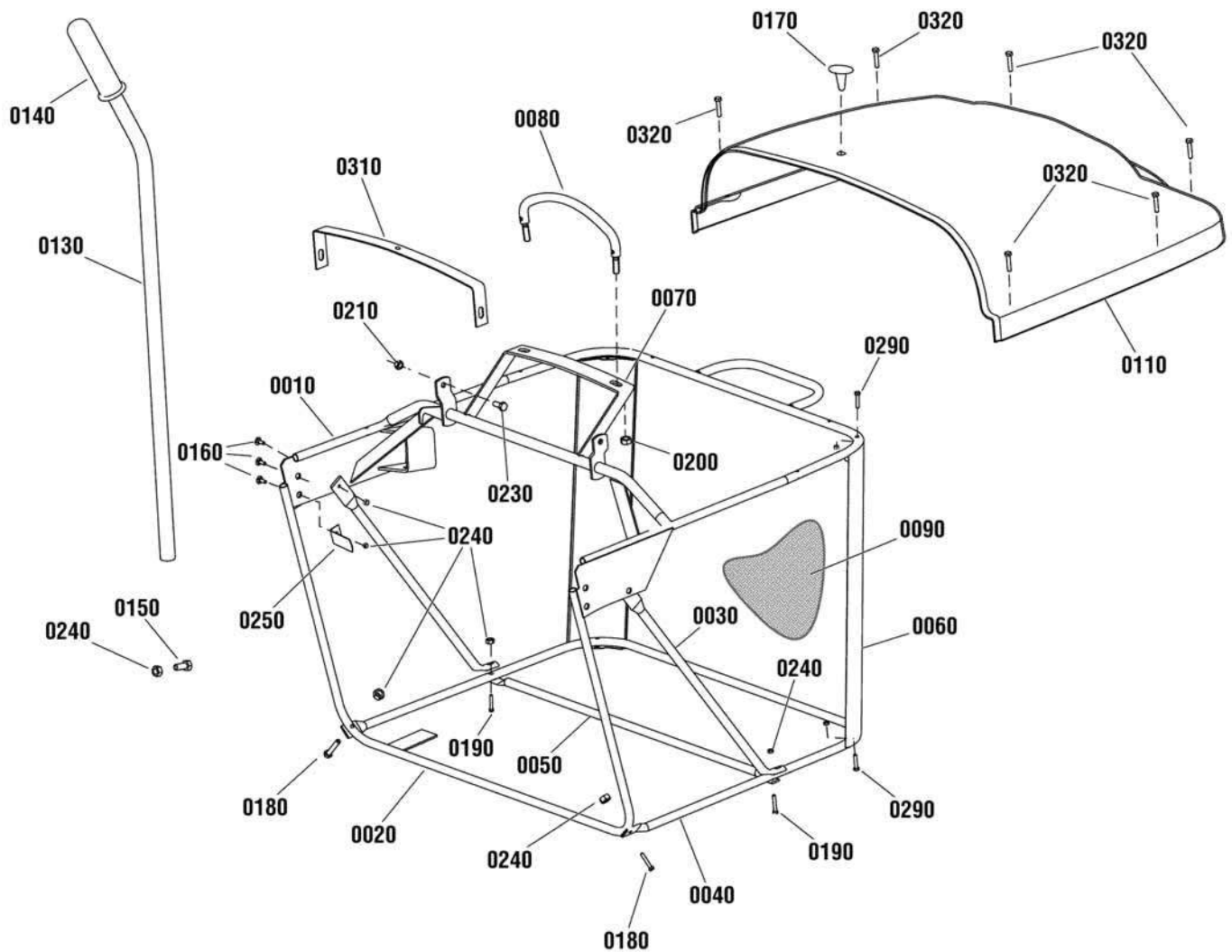

The above parts group applies to the following Mfg. Nos.:

- 2691075 - Regent
- 2691076 - Regent
- 2691077 - Regent
- 2691078 - Regent

Collector Group

REF NO	PART NO.	QTY.	DESCRIPTION
0010	1735897	1	FRAME, Top
0020	1736463	1	TUBE, Front
0030	1735877	2	BRACE
0040	1735984	1	TUBE, Bottom
0050	1735953	1	TUBE, Connecting
0060	1736236	1	REINFORCEMENT, Left
0070	1735954	1	REINFORCEMENT, Right
0080	1751833	1	HANDLE, Full
0090	1735885	1	COAT, Fabric
0110	1735981	1	TOP, Collector
0130	1735916	1	LEVER, Dumping
0140	1735901	1	HANDLE, Rubber
0150	1735859	1	BOLT, M5 x 12
0160	1735860	6	BOLT, M5 x 16
0170	1735948	1	PLUG, Plastic
0180	1735863	2	BOLT, M5 x 30
0190	1735864	2	BOLT, M5 x 35
0200	1751830	2	NUT, Flange Lock, M10
0210	1751829	2	NUT, Flange Lock, M8
0230	1735868	2	SCREW, M8 x 40
0240	1751831	15	NUT, M5
0250	1751832	1	SPRING, Flat
0290	1735862	4	BOLT, M5 x 25
0310	1735955	1	REINFORCEMENT, Top
0320	1736416	6	SCREW, 6.3 x 32

Not for
Reproduction

Footnotes

The above parts group applies to the following Mfg. Nos.:

2691075 - Regent
2691076 - Regent
2691077 - Regent
2691078 - Regent

French Guard Group

NOTE: Unless noted otherwise,
use the standard hardware torque
specification chart.

2988189a

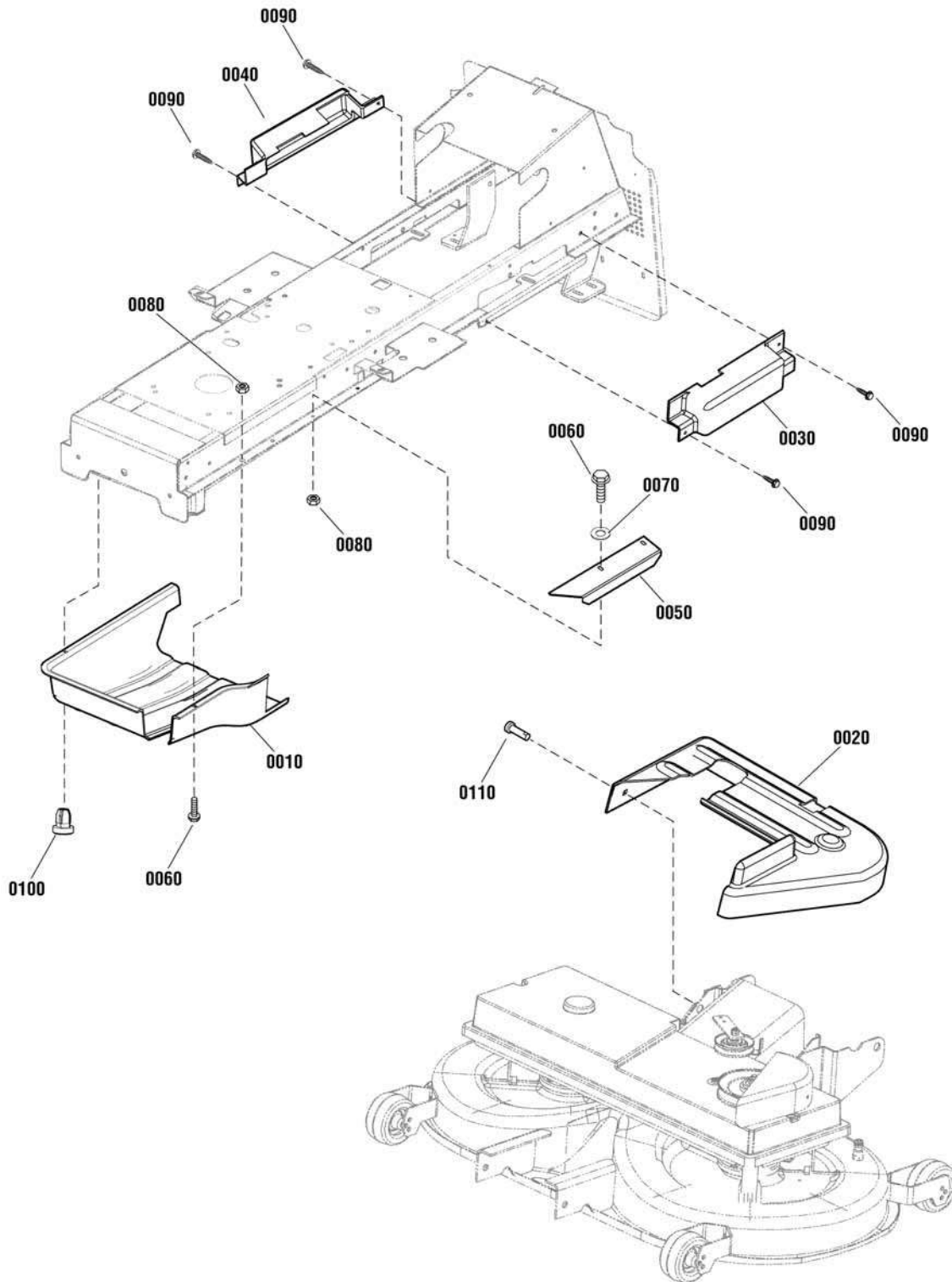

The above parts group applies to the following Mfg. Nos.:

2691076 - Regent

2691078 - Regent

French Guard Group

REF NO	PART NO.	QTY.	DESCRIPTION
0010	1737360	1	COVER, Clutch
0020	1737361	1	COVER, Mower Deck
0030	1737362	1	COVER, Roller, Left
0040	1737363	1	COVER, Roller, Right
0050	1737364	1	COVER, Side
0060	1735859	6	SCREW, M5 x 12
0070	1735997	2	WASHER
0080	1735931	6	NUT, M5
0090	1735961	4	SCREW, ST, 5.5 x 19
0100	1737365	2	HOUSING
0110	1737366	2	PIN

Not for
Reproduction

Footnotes

The above parts group applies to the following Mfg. Nos.:

2691076 - Regent

2691078 - Regent

40" Mower Deck - Belt & Idler Arm Group

NOTE: Unless noted otherwise,
use the standard hardware torque
specification chart.

2988004a

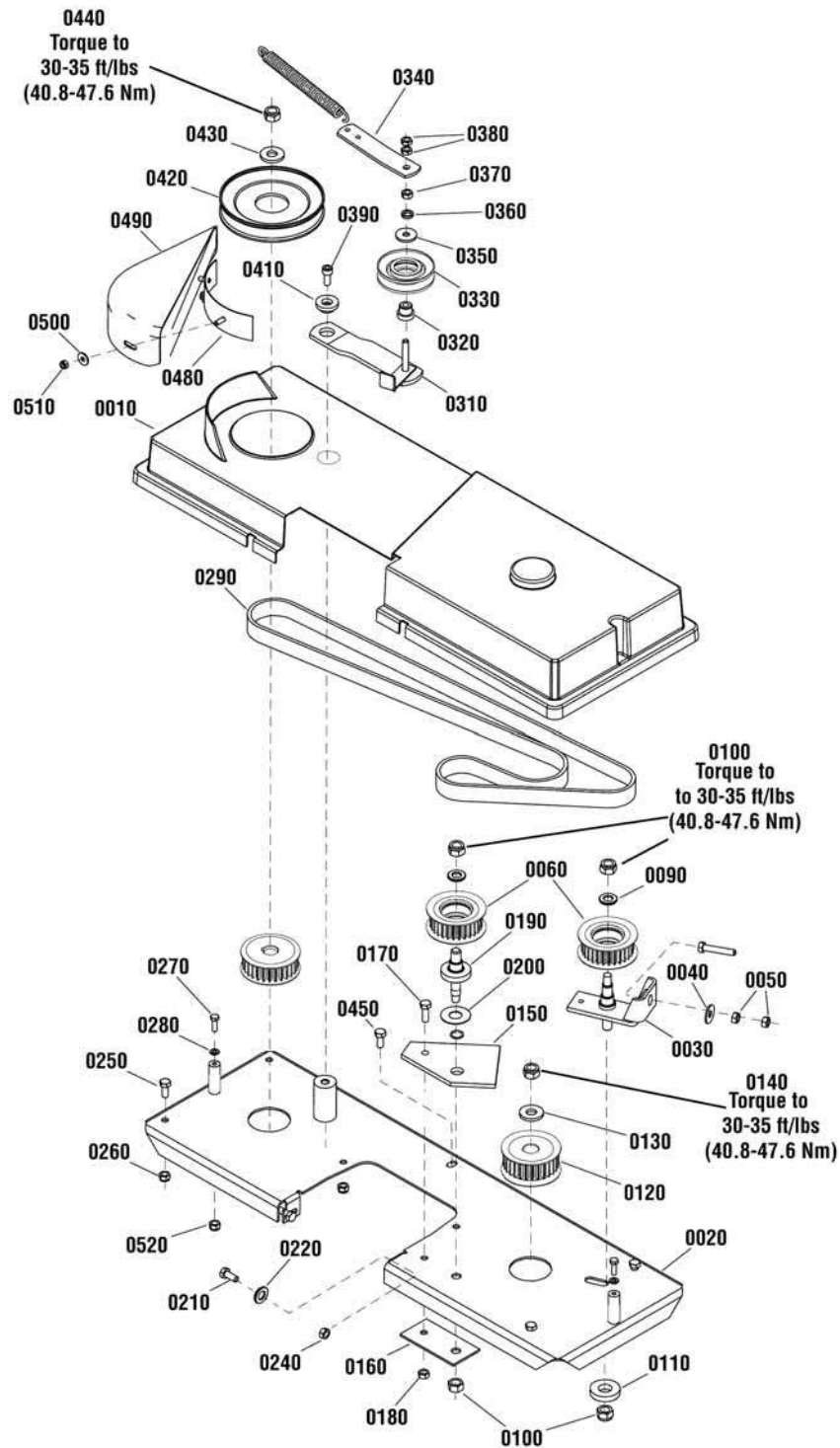

The above parts group applies to the following Mfg. Nos.:

- 2691075 - Regent
- 2691076 - Regent
- 2691077 - Regent
- 2691078 - Regent

40" Mower Deck - Belt & Idler Arm Group

REF NO	PART NO.	QTY.	DESCRIPTION
0010	1735802	1	COVER, Plastic 0-8547-369
0020	1735794	1	MAIN BOARD
0030	1735787	1	FOOTING, Complete
0040	1735846	1	WASHER, Zinc, 9
0050	1735799	2	NUT, M8
0060	1735781	2	PULLEY, Belt 28 Z
0090	1735837	2	WASHER, 13
0100	1735796	4	NUT, M12
0110	1735842	1	WASHER
0120	1735784	2	PULLEY, Belt
0130	1735834	1	WASHER, 0-9220-727
0140	1735796	1	NUT, M12
0150	1735804	1	REINFORCEMENT
0160	1735805	1	REINFORCEMENT
0170	1735818	1	SCREW, M8 x 25
0180	1751829	1	NUT, Flange Lock, M8
0190	1735827	1	STUD
0200	1735841	1	WASHER
0210	1735843	2	SCREW, Zinc M8 x 20
0220	1735837	2	WASHER, 13
0240	1751829	2	NUT, Flange Lock, M8
0250	1735820	6	SCREW, M8 x 40
0260	1751829	6	NUT, Flange Lock, M8
0270	1751834	2	SCREW, M6 x 16
0280	1735844	6	WASHER, Zinc, 6.6
0290	1735832	1	BELT, Two Side Tooth K+K20DS 1760
0310	1735790	1	HOLDER, Complete
0320	1735826	1	STUD, 0-9321-263
0330	1735811	1	ROLLER, W 3500-3712
0340	1737369	1	FOOTING
0350	1735845	1	WASHER, Zinc, 9
0360	1735838	1	WASHER, 8
0370	1735799	1	NUT, M8
0380	1735800	2	NUT, M8
0390	1735817	1	SCREW, M8 x 20 10.9 ZN DIN 912
0410	1735836	1	WASHER, 0-9221-222
0420	1735782	1	PULLEY, Belt 9-3325-234, Complete
0430	1735834	1	WASHER, 0-9220-727
0440	1735796	1	NUT, M12
0450	1751836	1	SCREW, M8 x 25
0480	1735806	1	REINFORCEMENT
0490	1735783	1	COVER, Pulley, Belt 0-8534-203
0500	1735844	2	WASHER, Zinc, 6.6
0510	1735798	2	NUT, M6

Footnotes

The above parts group applies to the following Mfg. Nos.:

2691075 - Regent
2691076 - Regent
2691077 - Regent
2691078 - Regent

40" Mower Deck - Belt & Idler Arm Group

NOTE: Unless noted otherwise,
use the standard hardware torque
specification chart.

2988004a

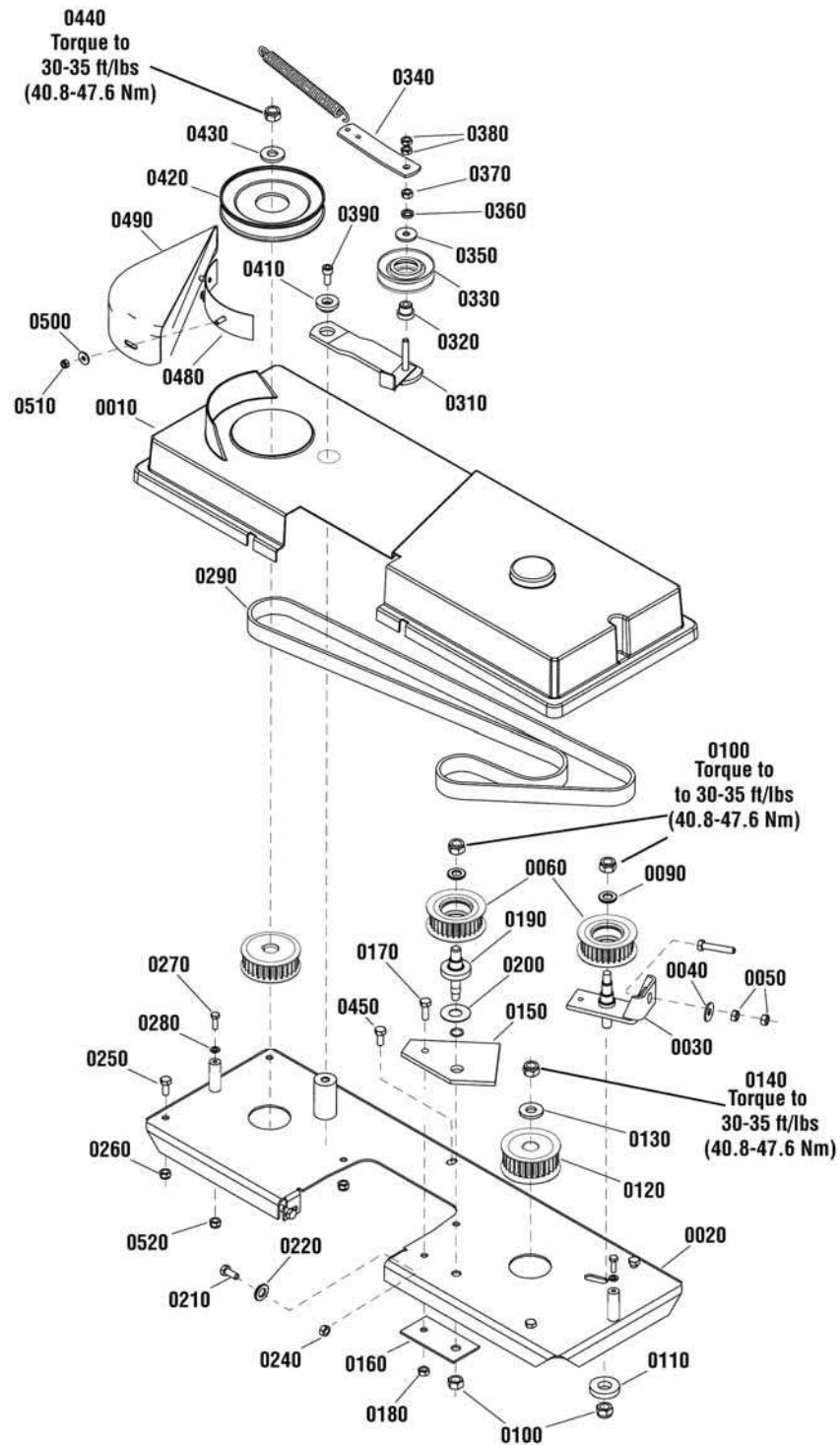

The above parts group applies to the following Mfg. Nos.:

- 2691075 - Regent
- 2691076 - Regent
- 2691077 - Regent
- 2691078 - Regent

40" Mower Deck - Belt & Idler Arm Group

REF NO	PART NO.	QTY.	DESCRIPTION
0520	1751835	2	NUT, Flange Lock, M6

Not for
Reproduction

Footnotes

The above parts group applies to the following Mfg. Nos.:

2691075 - Regent
2691076 - Regent
2691077 - Regent
2691078 - Regent

40" Mower Deck - Housing, Hitch, Arbors & Blades Group

2988005a

NOTE: Unless noted otherwise,
use the standard hardware torque
specification chart.

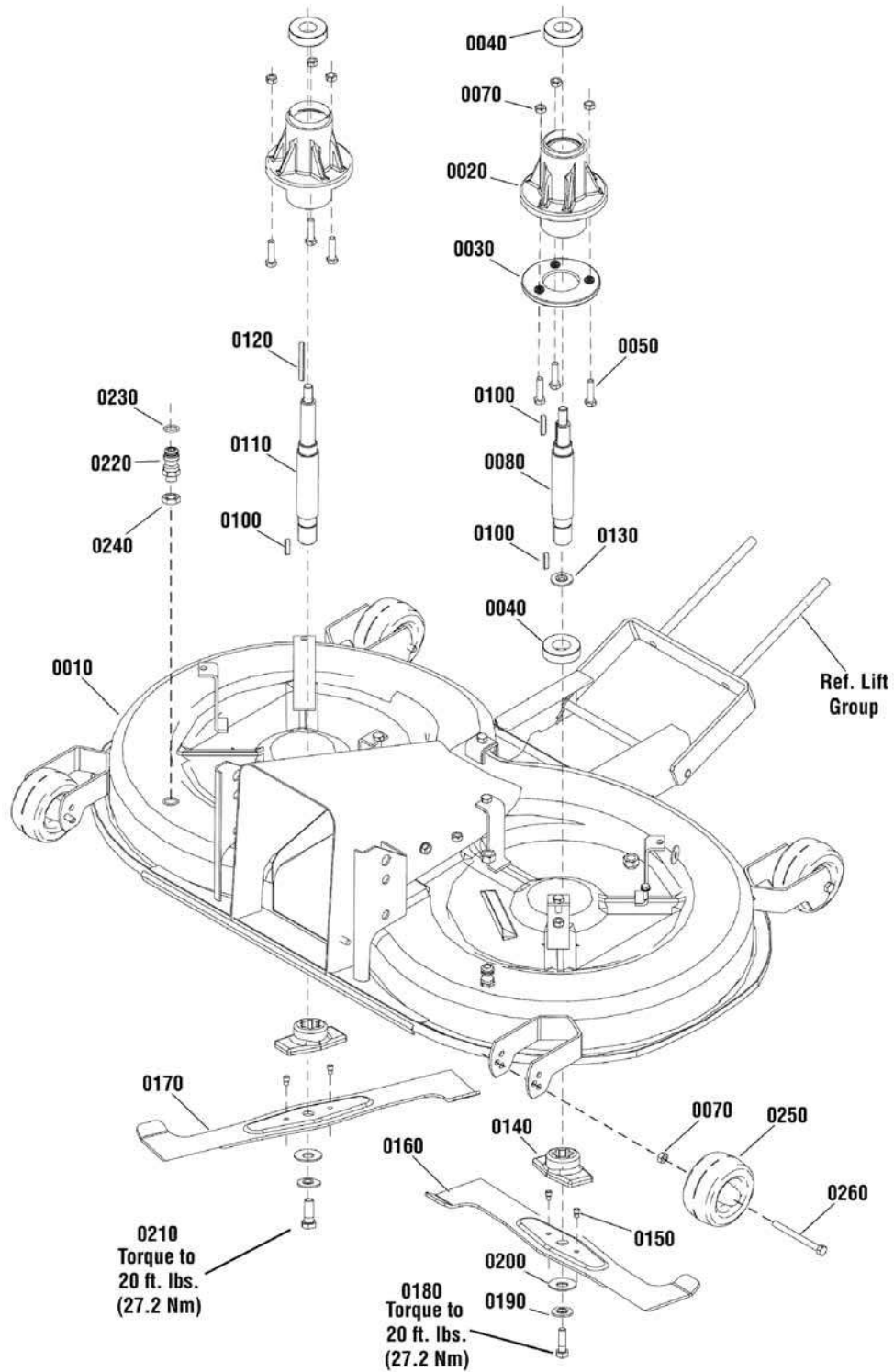

The above parts group applies to the following Mfg. Nos.:

- 2691075 - Regent
- 2691076 - Regent
- 2691077 - Regent
- 2691078 - Regent

40" Mower Deck - Housing, Hitch, Arbors & Blades Group

REF NO	PART NO.	QTY.	DESCRIPTION
0010	1737368	1	HOUSING , Mower Deck
0020	1735791	2	HOUSING , Spindle
0030	1735807	2	REINFORCEMENT
0040	1735780	4	BEARING, 6205 2 RS C 66IB
0050	1735819	6	SCREW, M8 x 35
0070	1751829	10	NUT, Flange Lock, M8
0080	1735823	1	SHAFT
0100	1751839	3	TONGUE, 6 H 9 x 6 x 28
0110	1735822	1	SHAFT
0120	1735831	1	TONGUE, 6 H 9 x 6 x 63
0130	1735812	2	RING, Safety 25
0140	1735792	2	HOUSING
0150	1735824	4	SHEAR STUD, 0-9311-736
0160	1735809	1	BLADE, Right Rotary
0170	1735793	1	BLADE, Left Rotary
0180	1735815	1	SCREW, M10, 0-9011-287
0190	1735835	2	WASHER, 0-9220-749
0200	1735840	2	WASHER, BN 806-40 x 16.3 x 2 x 3.1
0210	1735814	1	SCREW, 0-9011-283 M10, Left Thread
0220	1735803	2	QUICK FASTENER, 0-9026-246
0230	1735810	2	RING, 13 x 2 NBR
0240	1735797	2	NUT, M12
0250	1735808	4	CUTTING WHEEL, Right ETOP 100-8.2
0260	1735821	4	SCREW, M8 x 90

Not for
Reproduction

Footnotes

The above parts group applies to the following Mfg. Nos.:

2691075 - Regent
2691076 - Regent
2691077 - Regent
2691078 - Regent

Not for
Reproduction

Hardware Identification & Torque Specifications

Torque Specification Chart								
FOR STANDARD METRIC MACHINE HARDWARE (Tolerance ± 20%)								
Property Class	5.6		8.8		10.9		12.9	
	Class 5.6		Class 8.8		Class 10.9		Class 12.9	
Size Of Hardware	in/lbs	Nm.	in/lbs	Nm.	in/lbs	Nm.	in/lbs	Nm.
	ft/lbs		ft/lbs		ft/lbs		ft/lbs	
M3	5.88	.56	13.44	1.28	19.2	1.80	22.92	2.15
M4	13.44	1.28	30.72	2.90	43.44	4.10	52.56	4.95
M5	26.4	2.50	60.96	5.75	5.97	8.10	7.15	9.7
M6	44.64	4.3	7.3	9.9	10.3	14	12.1	16.5
M7	5.2	7.1	12.1	16.5	16.9	23	19.9	27
M8	7.7	10.5	17.7	24	25	34	29	40
M10	15	21	35	48	50	67	59	81
M12	26	36	61	83	86.2	117	103	140
M14	42	58	101	132	136	185	162	220
M16	64	88	147	200	210	285	250	340
M18	89	121	202	275	287	390	346	470
M20	126	171	290	390	405	550	486	660
M22	169	230	390	530	559	745	656	890
M24	217	295	497	375	708	960	840	1140
M27	320	435	733	995	1032	1400	1239	1680
M30	435	590	995	1350	1401	1900	1681	2280
M33	590	800	1349	1830	1902	2580	2278	3090
M36	759	1030	1740	2360	2441	3310	2935	3980
M39	988	1340	2249	3050	3163	4290	3798	5150

Torque Specification Chart						
FOR STANDARD MACHINE HARDWARE (Tolerance ± 20%)						
Hardware Grade	No Marks		SAE Grade 5		SAE Grade 8	
	SAE Grade 2		SAE Grade 5		SAE Grade 8	
Size Of Hardware	in/lbs	Nm.	in/lbs	Nm.	in/lbs	Nm.
	ft/lbs		ft/lbs		ft/lbs	
8-32	19	2.1	30	3.4	41	4.6
8-36	20	2.3	31	3.5	43	4.9
10-24	27	3.1	43	4.9	60	6.8
10-32	31	3.5	49	5.5	68	7.7
1/4-20	66	7.6	8	10.9	12	16.3
1/4-28	76	8.6	10	13.6	14	19.0
5/16-18	11	15.0	17	23.1	25	34.0
5/16-24	12	16.3	19	25.8	29	34.0
3/8-16	20	27.2	30	40.8	45	61.2
3/8-24	23	31.3	35	47.6	50	68.0
7/16-14	30	40.8	50	68.0	70	95.2
7/16-20	35	47.6	55	74.8	80	108.8
1/2-13	50	68.0	75	102.0	110	149.6
1/2-20	55	74.8	90	122.4	120	163.2
9/16-12	65	88.4	110	149.6	150	204.0
9/16-18	75	102.0	120	163.2	170	231.2
5/8-11	90	122.4	150	204.0	220	299.2
5/8-18	100	136	180	244.8	240	326.4
3/4-10	160	217.6	260	353.6	386	525.0
3/4-16	180	244.8	300	408.0	420	571.2
7/8-9	140	190.4	400	544.0	600	816.0
7/8-14	155	210.8	440	598.4	660	897.6
1-8	220	299.2	580	788.8	900	1,244.0
1-12	240	326.4	640	870.4	1,000	1,360.0

The guides and ruler furnished below are designed to help you select the appropriate hardware.



Nut, M8

Thread Diameter (mm)
Inside Diameter (in)
Threads per inch

Nut, 1/2-16

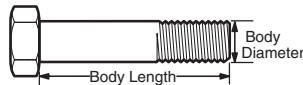

Screw, M8- 1.25 x 25

Thread Diameter (mm)
Body Diameter
Distance between threads (mm)
Threads per inch
Body Length (mm)
Body Length (in)

Screw, 1/2- 16 x 2

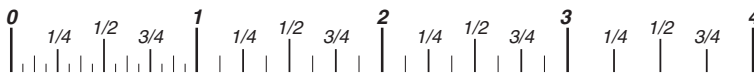

Standard Hardware Sizing

When a washer or nut is identified as **1/2"** (M8), this is the *Nominal size*, meaning the *inside diameter* is 1/2 inch (8mm metric thread diameter); if a second number is present it represents the *threads per inch* (distance between threads).

When bolt or capscrew is identified as **1/2 - 16 x 2"** (M8 - 1.25 x 50), this means the *Nominal size*, or body diameter is 1/2 inch (8mm metric thread diameter), the second number, 16, represents the *threads per inch*, (1.25 thread diameter). The final number is the body length of the bolt or screw, 2 inches (50mm).

NOTES

- These torque values are to be used for all hardware excluding: locknuts, self-tapping screws, thread forming screws, sheet metal screws and socket head setscrews.
- Recommended seating torque values for locknuts:
 - for prevailing torque locknuts - use 65% of grade 5 torques.
 - for flange whizlock nuts and screws - use 135% of grade 5 torques.
- Unless otherwise noted on assembly drawings, all torque values must meet this specification.

Common Hardware Types

Hex Head Capscrew

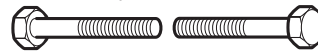

Washer

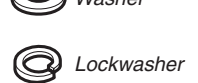

Carriage Bolt

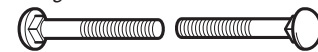

Hex Nut

Wrench & Fastener Size Guide

1/4" Bolt or Nut Wrench—7/16"	5/16" Bolt or Nut Wrench—1/2"	3/8" Bolt or Nut Wrench—9/16"	7/16" Bolt or Nut Wrench (Bolt)—5/8" Wrench (Nut)—11/16"	1/2" Bolt or Nut Wrench—3/4"
M6 Bolt or Nut Wrench—10mm	M8 Bolt or Nut Wrench—13mm	M10 Bolt or Nut Wrench—17mm	M12 Bolt or Nut Wrench—19mm	M14 Bolt or Nut Wrench—22mm

Not for
Reproduction

**IT IS THE POLICY OF BRIGGS & STRATTON CORP. TO IMPROVE ITS PRODUCTS
WHENEVER IT IS POSSIBLE AND PRACTICAL TO DO SO. WE RESERVE THE RIGHT TO
MAKE CHANGES OR ADD IMPROVEMENTS AT ANY TIME WITHOUT INCURRING ANY
OBLIGATION TO MAKE SUCH CHANGES ON PRODUCTS.**

Briggs & Stratton Yard Power Products Group

3515 N. 124 Street / PO Box 702
Wauwatosa, WI 53222 USA

www.simplicitymfg.com

© Copyright 2012 by Briggs & Stratton Corporation
Milwaukee, WI, USA. All rights reserved