

Parts Manual for

SNAPPER®

YARD TRACTOR ELECTRIC CLUTCH HYDRO DRIVE RD RMO EUROPEAN 2010

<i>Model No.</i>	<i>Description</i>
2690851	ELT1840RD
2690855	ELT1840RDFR
2690852	ELT2240RD
2690856	ELT2440RDFR



Briggs & Stratton Yard Power Products Group

535 Macon Road
McDonough, GA, 30253 U.S.A.
800-935-2967

Manual No. 7104240
Revision: - 1/20/2010

Not for
Reproduction

PAGE	GROUP
4	Wheels & Tires Group
6	Hood, Grille & Dash Group
8	Seat Deck & Fuel Group
10	Steering Group
12	Frame & Front Axle Group
14	Engine Group - 18HP & 24HP
16	Controls Group
20	Transmission SERVICE PARTS - Tuff Torq K46CW (1735476)
24	Decals Group
26	Lift Group - Manual
28	40" Mower Deck - Belt & Idler Arm Group
32	40" Mower Deck - Housing, Hitch, Arbors & Blades Group
34	Back Plate Group - 18HP & 24HP
36	Rear Discharge Deflector Group
38	Collector Group
40	Mulching Flap Group
42	French Guard Group
44	Electrical Group - 18HP & 24HP

Not for
Reproduction

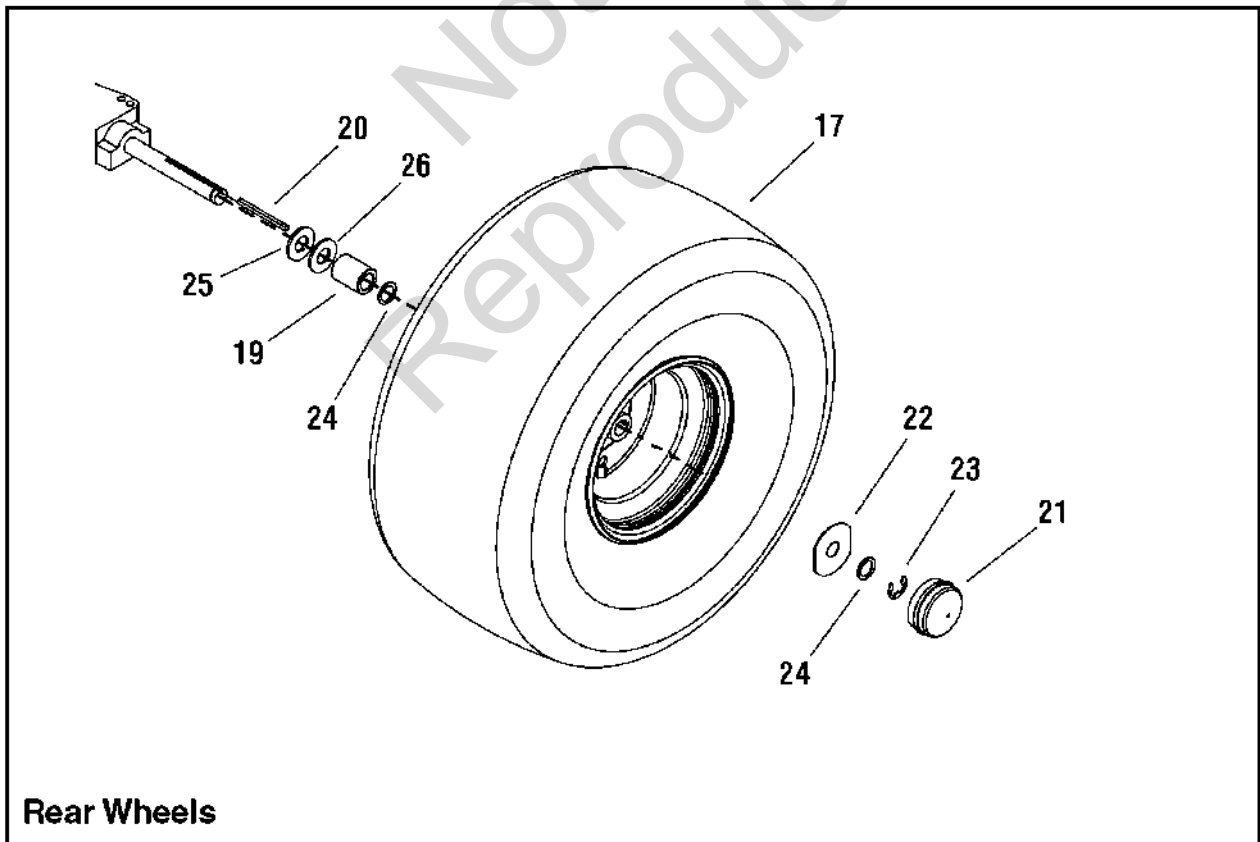
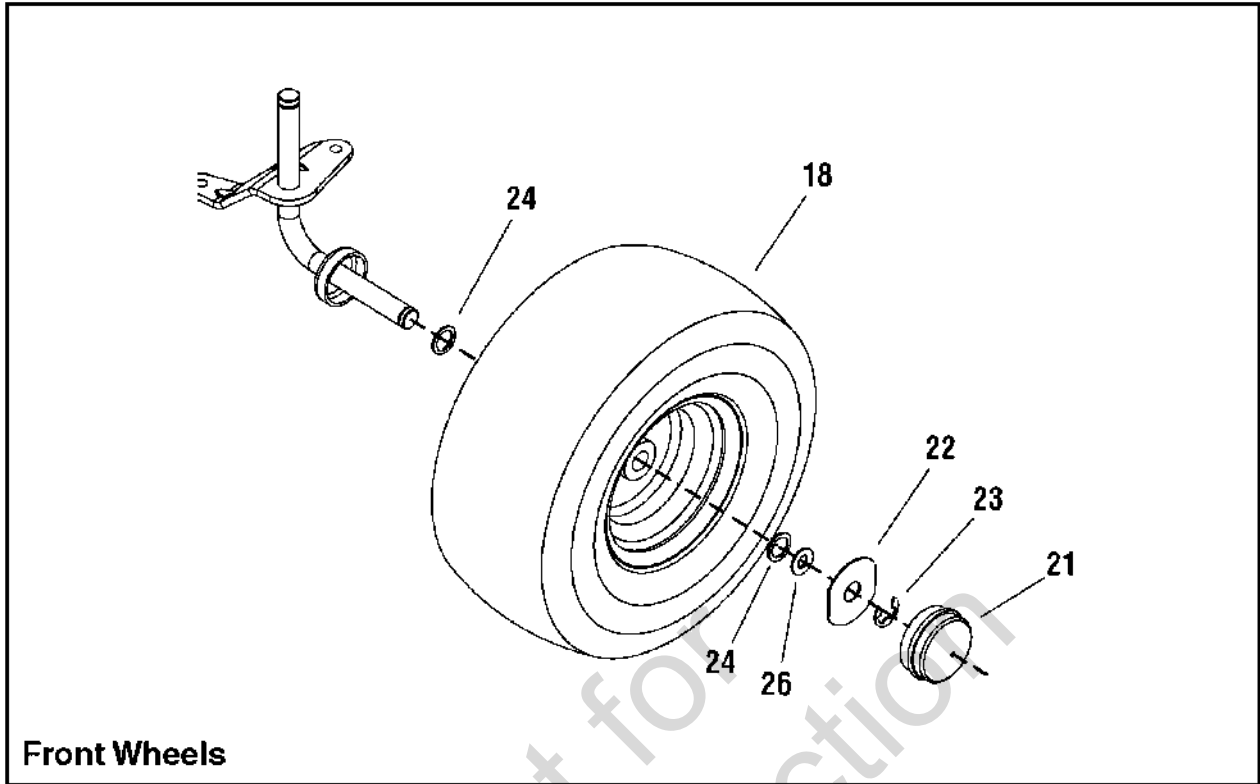

Wheels & Tires Group

Item	Part No	Qty	Description
17	1732324	2	WHEEL & TIRE ASSEMBLY, Rear, 22 x 10 - 8
18	1729708	2	WHEEL & TIRE ASSEMBLY, Front, 14.4 x 6
19	1730181	2	SPACER, Axle, Rear PM Hunter
20	1713409	2	KEY, Parallel
21	1722676	4	HUB CAP, 2.361 D, Grey Poly 1.3H, VIPER
22	1722717	4	WASHER, Special, 2-1/2
23	2827794	4	RING, Klipring, EXT For .75 Dia Shaft blk
24	2860183	8	WASHER, 3/4
25	2860202	2	WASHER, 3/4
26	1735988	8	WASHER

Not for
Reproduction

Footnotes:

Hood, Grille & Dash Group

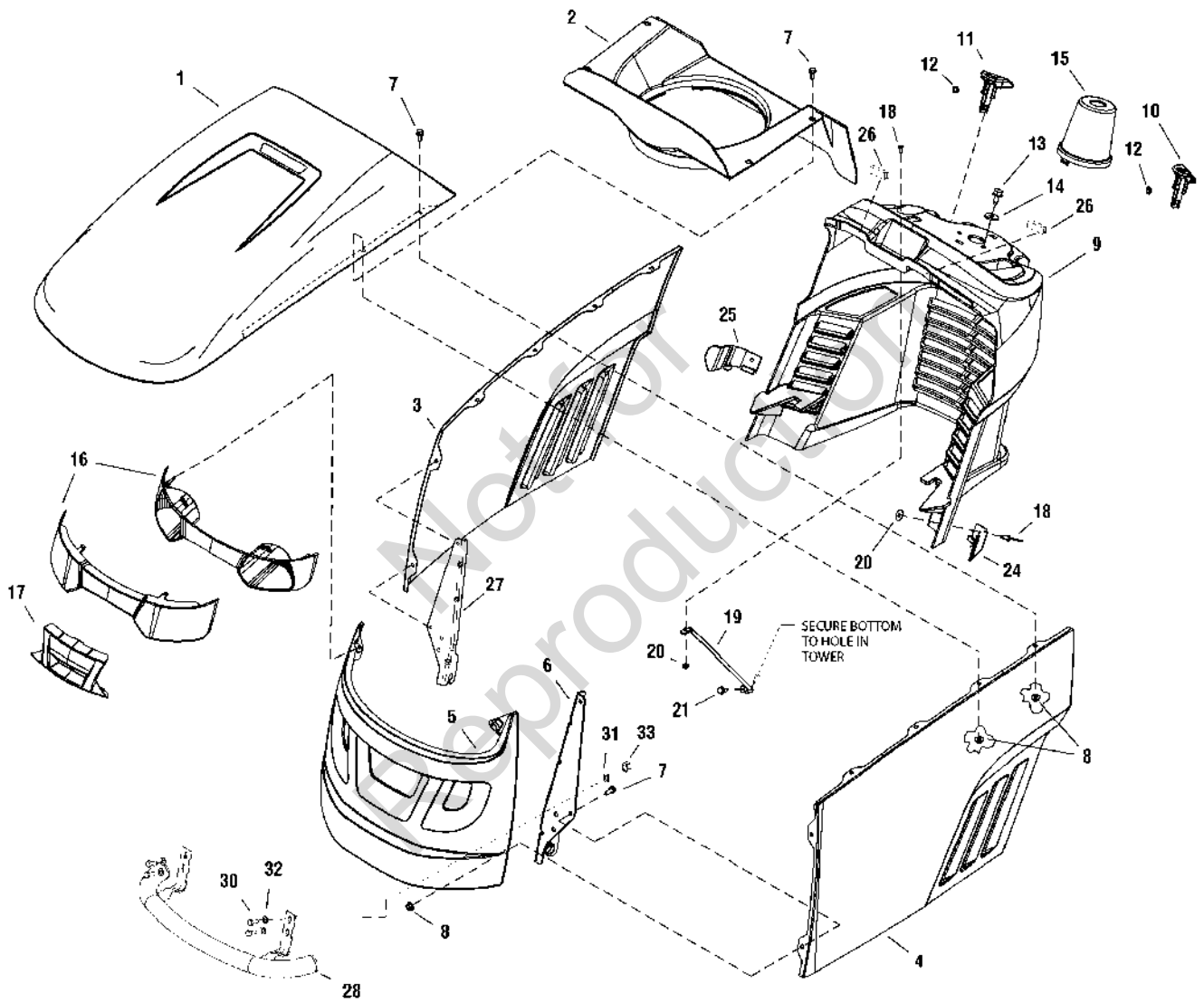

Hood, Grille & Dash Group

Item	Part No	Qty	Description
1	1728031D	1	HOOD, With Scoop
2	1733457	1	DUCT, Air Inlet
3	1727294D	1	PANEL, Hood, Right
4	1727295D	1	PANEL, Hood, Left
5	1728059D	1	GRILLE
6	1727279	1	HINGE, Hood, Left
7	1960295	12	CAPSCREW, Hex Lock, 1/4-20 x 5/8
8	1930641	12	NUT, Hex Flange Lock, 1/4-20
9	1727293	1	DASHBOARD
10	1728089	1	KNOB, Brake Lock
11	1728090	1	KNOB, Cruise Lock
12	1960518	2	NUT, Push Pal, 1/4
13	1664847	2	CAPSCREW, Hex Taptite, 5/16-18 x 3/4
14	1919381	2	WASHER, 5/16
15	1727999	1	COVER, Steering Shaft
16	1727296	1	HEADLIGHT ASSEMBLY
17	1728975	1	INSERT, Light Bar
18	1960392	3	SCREW, Phillips Head
19	1723123	1	ROD, Dash Support
20	1933896	3	NUT, Flange
21	1925003	1	SCREW, Self Tap
24	1732030	1	GUIDE, Hood, Left
25	1732031	1	GUIDE, Hood, Right
26	1735878	2	BRAID, Steel-Insert 0-9634-219
27	1727280	1	HINGE, Hood, Right
28	1735879	1	BUMPER, Front
30	1735868	4	BOLT, M8 x 20
31	1735989	4	WASHER, 8.4
32	1736000	4	WASHER, 8
33	1735934	4	NUT, M8

Footnotes:

Seat Deck & Fuel Group

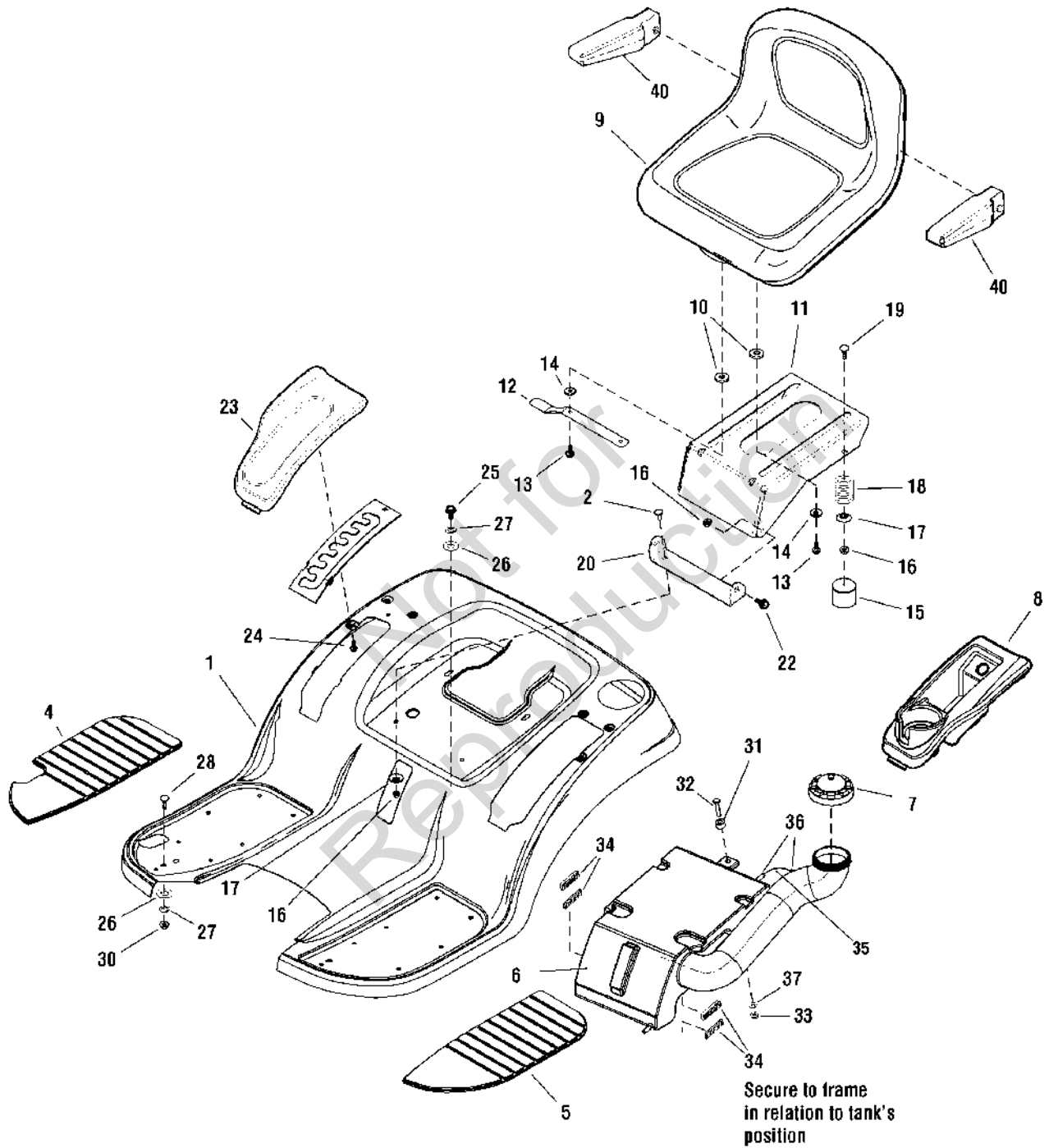

Seat Deck & Fuel Group

Item	Part No	Qty	Description
1	1727264D	1	DECK, Seat With Foot Rests
2	1931333	2	BOLT, 5/16-18 x 3/4
4	1728007	1	PAD, Footrest, Right
5	1728006	1	PAD, Footrest, Left
6	1735976	1	TANK, Fuel 9-2770-244
7	1715917	1	CAP, Fuel
8	1729001	1	POD, Cup Holder, Left
9	1730159	1	SEAT, High Back
9	1739212	1	SEAT, High Back
10	1731300	4	SPACER
11	1727265	1	SUPPORT, Seat
12	1727268	1	LATCH, Seat
13	1960667	4	SCREW, Flange 5/16-18 x 1
14	1919381	4	WASHER, 5/16
15	1704724	2	COVER, Spring
16	1960686	6	NUT, Hex Flange, 5/16-18
17	1709256	4	WASHER, Spring
18	1704728	2	SPRING, Compression
19	1960282	2	BOLT, Carriage, 5/16-18 x 3/4
20	1727266	1	PIVOT, Seat
22	1729576	2	BOLT, Shoulder, 5/16-18 x 1/8
23	1729000	1	POD, Lift, Right
24	1960536	6	SCREW, Hex, 1/4-1/2
25	1735854	2	BOLT, M8 x 16
26	1735989	4	WASHER, 8.4
27	1736000	4	WASHER, 8
28	1735869	2	BOLT, M8 x 20
30	1735937	2	NUT, M8
31	1735894	1	DISTANCE, Lift 0-9521-289
32	1735867	1	BOLT, M6 x 30
33	1735932	1	NUT, M6
34	1735878	4	BRAID, Steel Insert 0-9634-219
35	1735914	1	HOSE, Air Escape 1-9920-248
36	1735883	2	CLIP, UM 5008
37	1735999	1	WASHER, 6.6
40	1687021	1	KIT, Arm Rest

Footnotes:

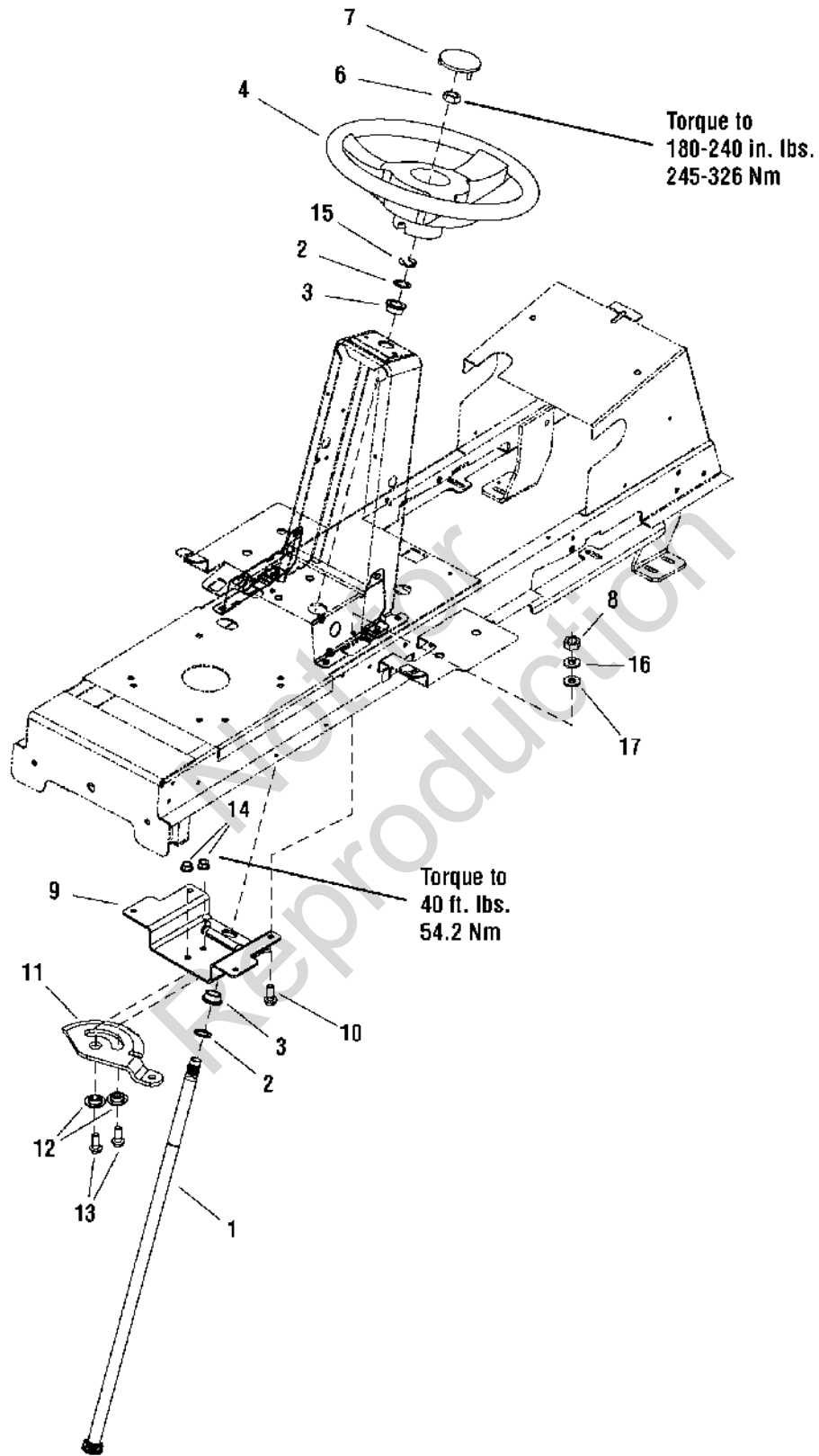

Steering Group

Item	Part No	Qty	Description
1	1727813	1	SHAFT, Steering Gear & Spline
2	1960114	2	WASHER, 3/4
3	1729665	2	BUSHING
4	1728069	1	STEERING WHEEL
6	1960576	1	NUT, Hex Lock 5/8-18
7	1725024	1	CAP, Steering Wheel, Snapper
8	1735934	4	NUT, M8
9	1727940	1	BRACKET, Sector Support
10	1735870	4	BOLT, M8 x 25
11	1728027	1	GEAR, Steering , 1/4 Thick, 26 teeth
12	1728122	2	SPACER, Sector Gear
13	1934654	2	SCREW, Hex Lock Flange, 3/8-16 x 1
14	1931211	2	NUT, Hex Flange, 3/8-16
15	1611710	1	RING, Klipring
16	1735989	4	WASHER, 8.4
17	1736000	4	WASHER, 8

Not for
Reproduction

Footnotes:

Frame & Front Axle Group

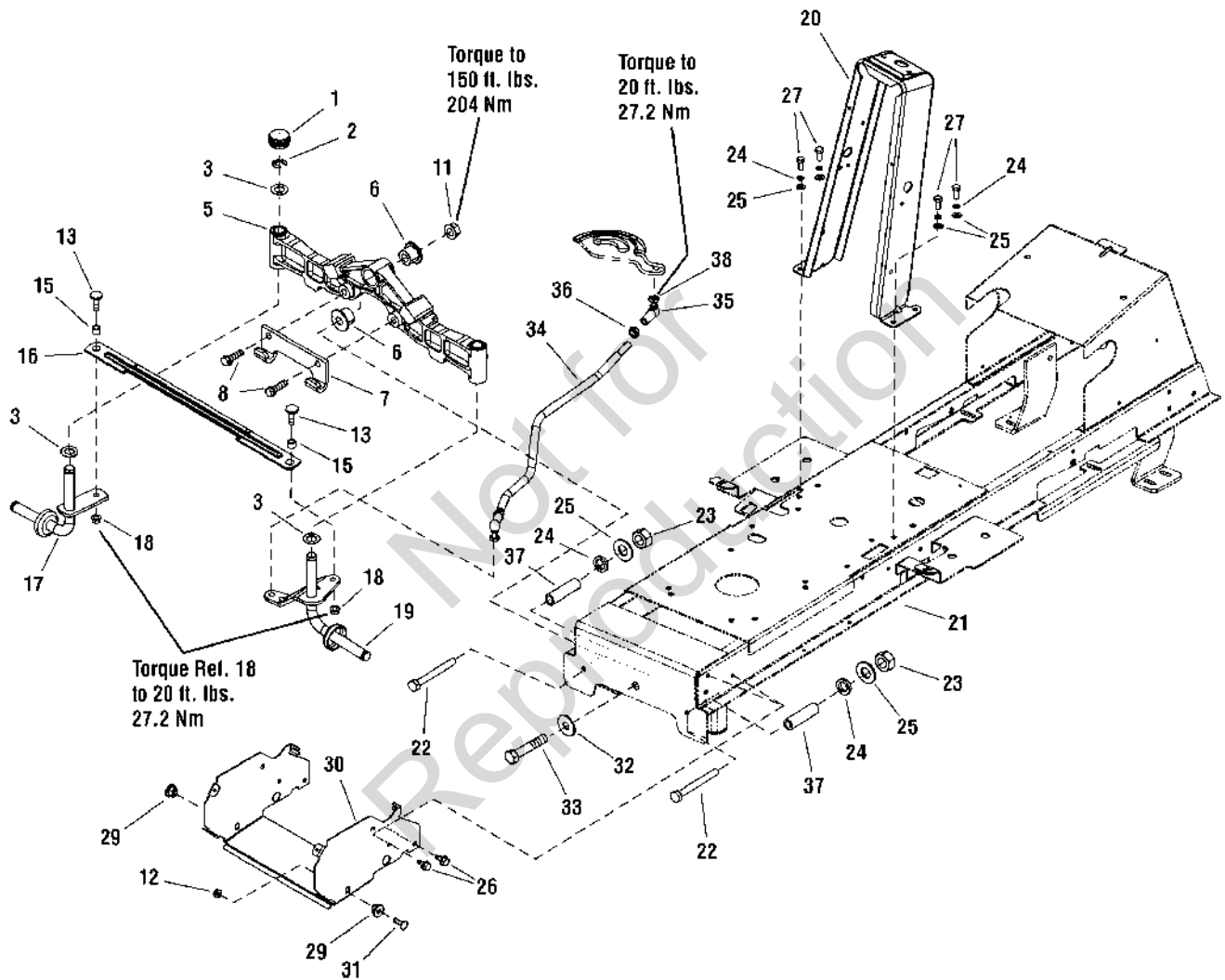

Frame & Front Axle Group

Item	Part No	Qty	Description
1	1726504	2	HUB CAP
2	1611710	2	RING, Klipring
3	2860183	4	WASHER, 1-5/8
5	1728018	1	AXLE, Front (Includes Ref. Nos. 1, 2, 3, 17 & 19)
6	1730186	2	BUSHING, Axle Pivot
7	1721918A	1	HOOK, Hitch 5/16 THK
8	1960652	2	CAPSCREW, 7/16-14 x 1-1/2
11	2860646	1	NUT, Hex Flange 5/8-11
12	1931277	2	NUT, Hex Flange, 5/16-18
13	1960032	2	CAPSCREW, Hex 3/8-16 x 1-1/4
15	1731912	2	SPACER
16	1728080A	1	ROD, Tie
17	1727872A	1	SPINDLE & CUP ASSEMBLY, Right
18	1930645	2	NUT, Hex Flange, 3/8-16
19	1727873A	1	SPINDLE & CUP ASSEMBLY, Left
20	1727260	1	TOWER
21	1736499	1	FRAME
22	1735874	2	BOLT, M8 x 75
23	1735934	2	NUT, M8
24	1735989	6	WASHER, 8.4
25	1736000	6	WASHER, 8
26	1930601	4	CAPSCREW, Hex Washer Head, Taptite, 5/16-18 x 5/8
27	1735868	4	BOLT, M8 x 20
29	1728086	2	PIVOT, Hood
30	1735973	1	SUPPORT, Muffler
31	1931335	2	BOLT, Carriage, 5/16-18 x 1
32	1960035	1	WASHER, 5/8
33	2860744	1	CAPSCREW, Hex, 5/8-11 x 3-1/4
34	1735919	1	LINK, Drag
35	1735851	2	BALL JOINT, CS16 M10-M12
36	1735928	2	NUT, M12
37	1735892	2	DISTANCE, Front axle 0-9521-29
38	1735926	2	NUT, M10 DIN6923 8

Footnotes:

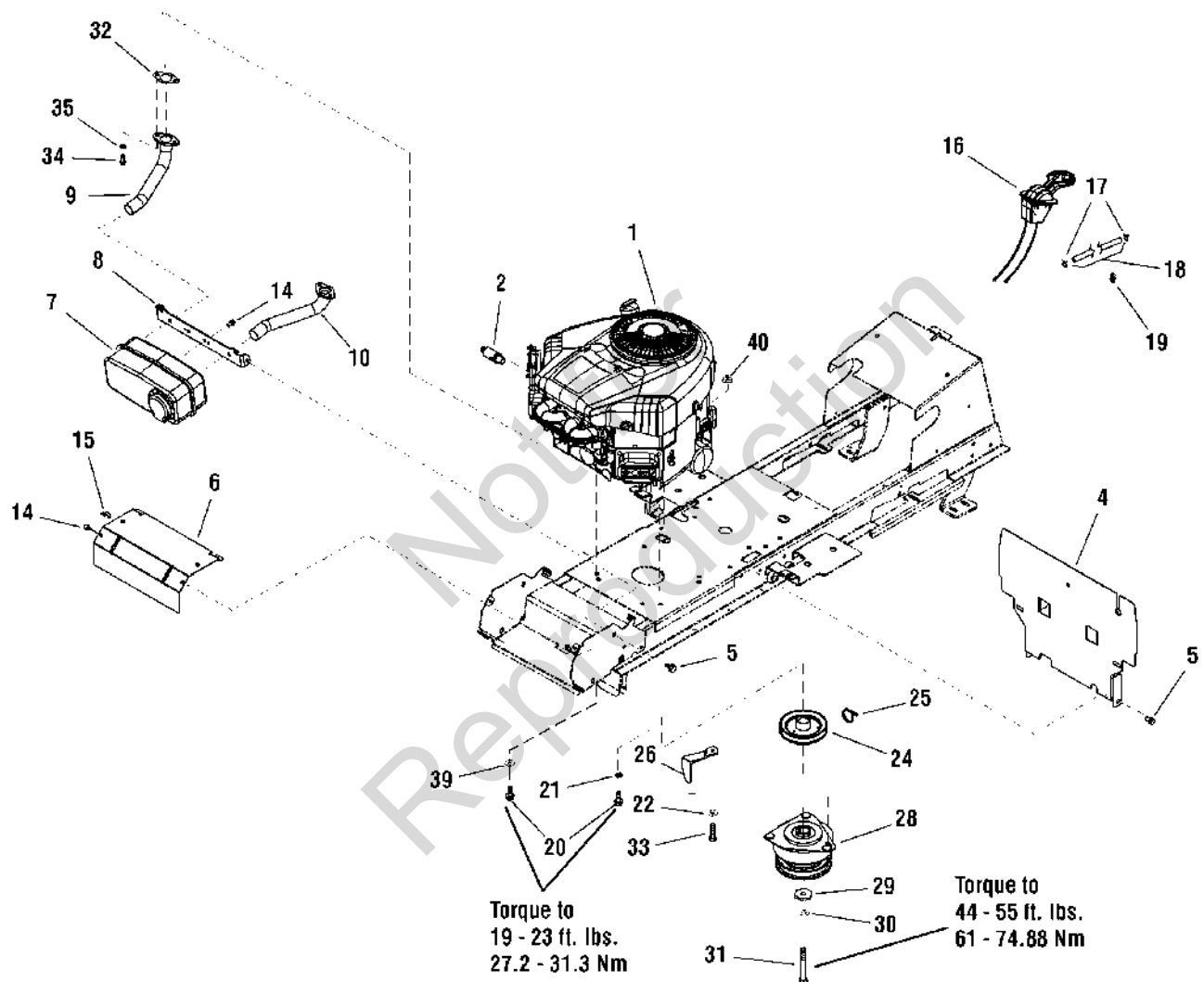

Engine Group - 18HP & 24HP

Item	Part No	Qty	Description
1	405577-0130-B1	1	* ENGINE, 18HP, B&S Twin (Engine Model: 405577-0130-B1)
1	445677-0129-B1	1	* ENGINE, 24HP, B&S Twin (Engine Model: 445677-0129-B1)
2	1717473	1	VALVE, Shut-off
4	1735962	1	HEAT SHIELD
5	1930601	4	SCREW, Taptite, 5/16-18 x 5/8
6	1727997	1	HEAT SHIELD
7	1727994	1	MUFFLER, B&S Twin
8	1727976	1	BRACKET, Muffler Mount
9	1727980	1	PIPE, Exhaust, LH Side
10	1727979	1	PIPE, Exhaust, RH Side
14	1925003	4	SCREW, Taptite, 1/4-20 x 1/2
15	2834683	1	CLIP, Wire
16	1734505	1	CONTROL, Throttle (34.75" & 36.5")
17	1735883	2	CLAMP, Hose UM5008
18	1735913	1	HOSE, Fuel 1-9920-247
19	1730268	2	CLIP, Hose
20	2827187	3	SCREW, Taptite, 3/8-16 x 1
21	2820427	1	WASHER, Lock, External Tooth, 3/8
22	1924940	1	WASHER, Flat. 3/8
24	1732576	1	PULLEY & HUB ASSEMBLY
25	1735980	1	TIE
26	1732875	1	ROD, Clutch Retainer, Long (BLK)
28	1732833	1	CLUTCH, Electric (LONG OGURA)
29	1708264	1	WASHER, Hex 1/2
30	1918199	1	LOCKWASHER, 7/16
31	1960649	1	CAPSCREW, Hex Head 7/16-20 x 3-1/2
32	1731214	1	GASKET, Exhaust
33	2828635	1	SCREW, Hex Head, 3/8-16 x 1-1/4
34	1936228	2	SCREW
35	1917356	2	LOCKWASHER
39	1736999	4	WASHER, 8.4
40	1737000	4	NUT, 8

Footnotes:

NOTE: * See your local Briggs & Stratton distributor for parts and service.

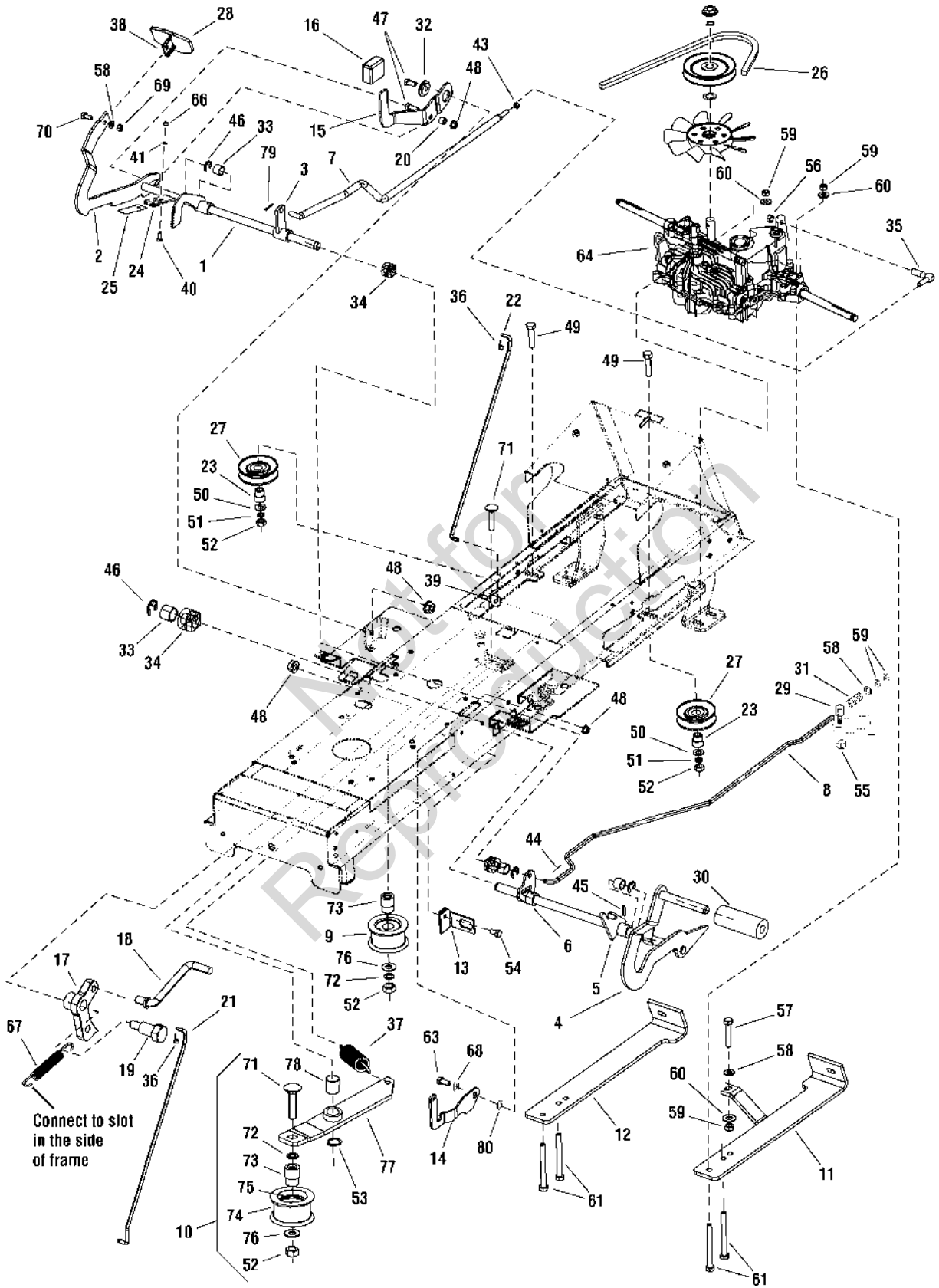

Controls Group

Item	Part No	Qty	Description
1	1735940	1	PEDAL, Forward
2	1735952	1	RATCHET
3	1735847	1	ARM
4	1735941	1	PEDAL, Brake
5	1735918	1	LEVER, Parking Brake
6	1735917	1	LEVER, Brake
7	1735959	1	ROD, Traveling
8	1735957	1	ROD, Brake
9	1735951	1	PULLEY, Tensioning
10	1735950	1	PULLEY, Idler (Incl. Ref. Nos. 52, 71, 72, 73, 74, 75, 76, 77, & 78)
11	1735910	1	HOLDER, Left
12	1735911	1	HOLDER, Right
13	1735974	1	SUPPORT, Switch
14	1735595A	1	LATCH, Brake Lock
15	1727246	1	PEDAL, Reverse
16	1727259	1	PAD, Foot Pedal
17	1727897	1	LATCH, Cruise
18	1727899	1	ROD, Cruise 5/16 Dia. x 2.83"
19	1728976	1	BOLT, Shoulder, 5/16-18 x 1-5/8
20	1728024	1	SPACER, Foot Pedal
21	1727898	1	ROD, Cruise Latch, Upper
22	1727267	1	ROD, 15.95 lg
23	1735880	2	BUSHING, 0-9421-418
24	1736001	1	WASHER, Lock
25	1735972	1	SPRING, Flat 0-9740-221
26	1735987	1	V-BELT, Li, BBT, 13 x 2580
27	1735949	2	PULLEY, Compensa C-00237/1
28	1735942	1	PEDAL, Forward Rubber
29	1735853	1	BOLT, 0-9016-447
30	1727261	1	PEDAL, Brake Pad
31	1735968	1	SPRING, TLZ 250.150.0530 Yellow
32	1727935	1	SPACER, Pivot
33	1735896	4	DISTANCE, Pedal 0-9521-288
34	1735881	4	BUSHING, 0-9462-202
35	1735850	1	BALL JOINT, CS 13 DIN 71802 M8, Silver
36	1728111	2	CLIP, Linkage .250 dia
37	1735969	1	SPRING, TZ 2x14x62, Yellow
38	1735943	1	PEDAL, Forward, Top
39	1735875	1	BOLT, Eye M6x80 BN1006
40	1735866	1	BOLT, M6 x 16
41	1735998	2	WASHER, 6.4
43	1735936	1	NUT, M8
44	1735963	2	SPINDLE, 2 x 20
45	1735946	4	PIN, Flex. 5 x 25

Footnotes:

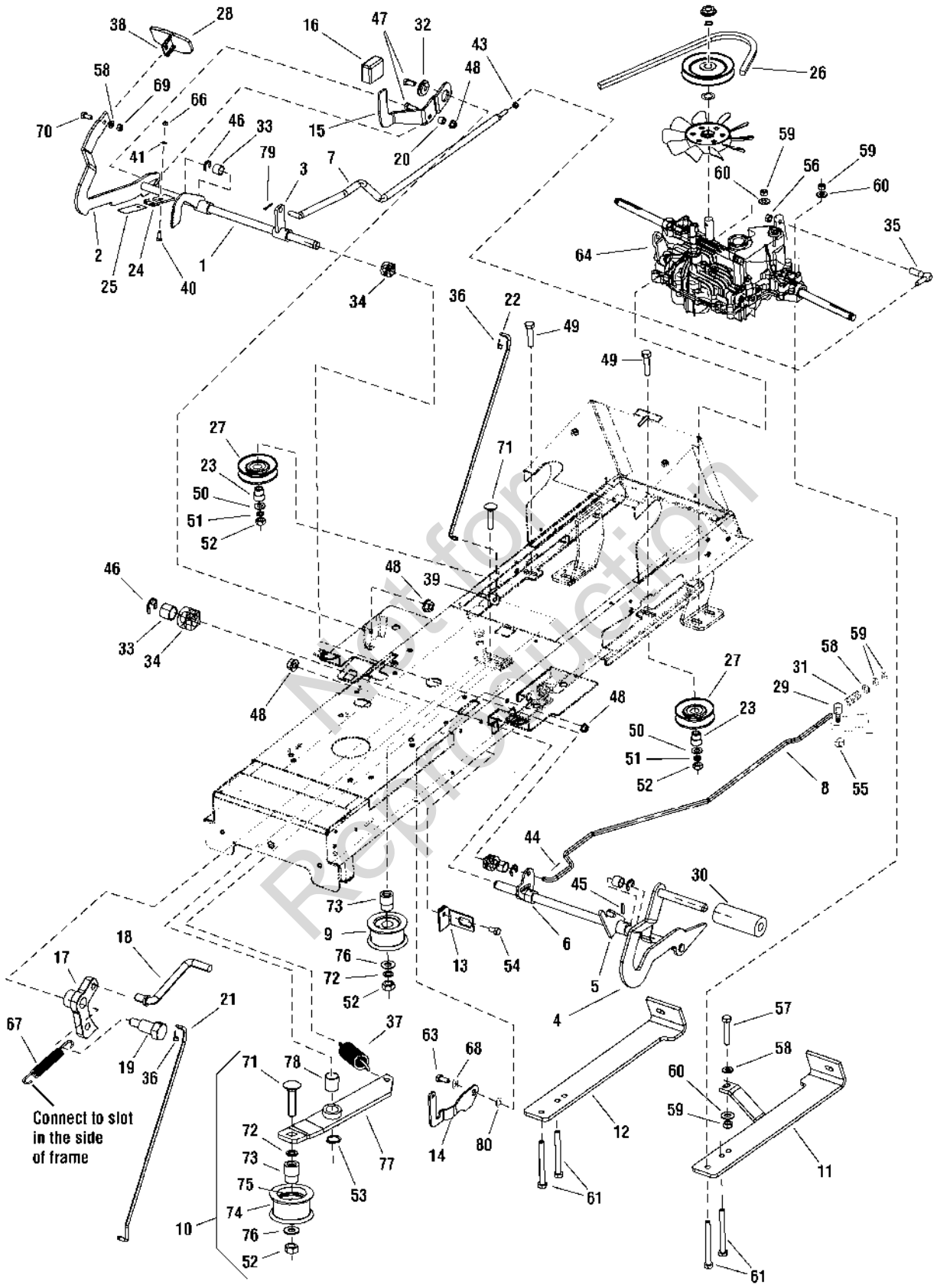

Controls Group

Item	Part No	Qty	Description
46	1735920	4	LOCK RING, 12
47	1960223	2	BOLT, Carriage, 5/16-18 x 1-1/4
48	1931277	4	NUT, Hex Flange, 5/16-18
49	1735855	2	BOLT, M10 x 40
50	1735990	2	WASHER, 10.5
51	1735991	2	WASHER, 10.0
52	1735925	4	NUT, M10
53	1735921	1	LOCK RING, 16
54	1930601	1	SCREW, Tap, 5/16-18 x 5/8
55	1735924	1	NUT, M10
56	1735938	1	NUT, M8 DIN 6923 8 Yellow, Tooth
57	1735873	1	BOLT, M8 x 45
58	1735989	7	WASHER, 8.4
59	1735934	7	NUT, M8
60	1736000	5	WASHER, 8
61	1735874	4	BOLT, M8 x 75
63	1729576	1	BOLT, Shoulder 5/16-18 x 1-3/16
64	1729589	1	TRANSMISSION, Tuff Torq, K-46BL (Early Models)
64	1735476	1	TRANSMISSION, Tuff Torq, K-46CW (Late Models)
66	1735933	3	NUT, M6
67	2159181	1	SPRING
68	1735994	3	WASHER, 14x26/0.2
69	1735935	1	NUT, M8
70	1735854	1	BOLT, M8 x 16
71	1736455	2	SCREW, M10 x 45
72	1736456	2	LOCK RING, 40
73	1736457	2	BUSHING, Pulley, Tension
74	1736458	1	PULLEY
75	1736459	1	BALL BEARING, Pulley, 62032RS
76	1736460	2	WASHER, 11
77	1736461	1	ARM, Pulley, Tension
78	1736462	1	BEARING, Slide
79	1735964	1	SPINDLE, 3.2 x 25
80	1739135	1	WASHER, 16 x 22 x 1

Footnotes:

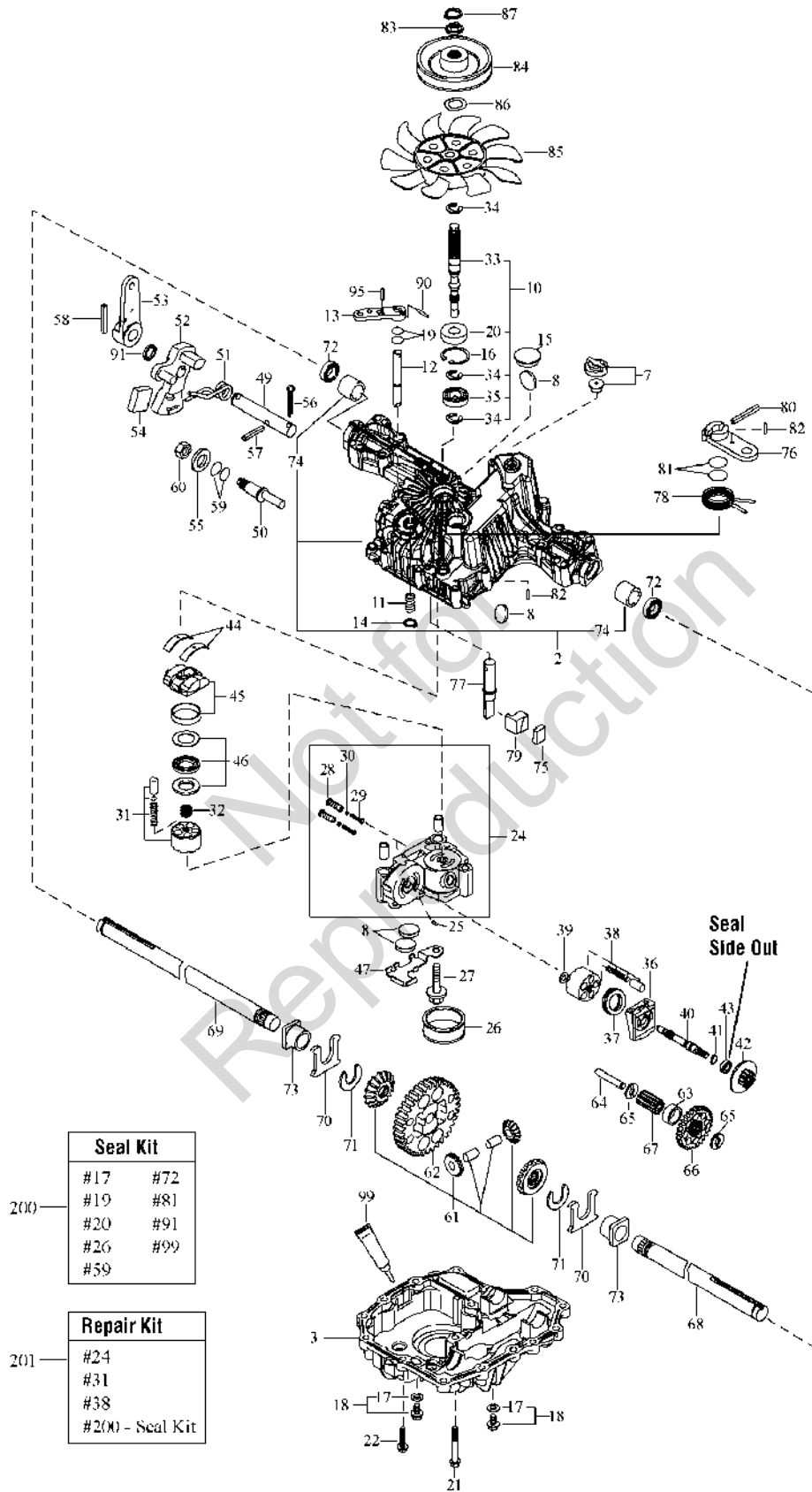

Transmission SERVICE PARTS - Tuff Torq K46CW (1735476)

Item	Part No	Qty	Description
--	1735476		TRANSMISSION, Tuff Torq, K46CW
2	----		*KIT, Upper Case
3	1724278		LOWER CASE
7	1739891		VENT VALVE
8	1724279		MAGNET
10	----		*KIT, Pump Shaft / Bearing
11	----		*SPRING 25
12	----		*BYPASS SHAFT
13	1720418		LEVER, Bypass
14	----		*RING, Snap, 10
15	1724282		SEALING CAP 30
16	1708650		SNAP RING C 35
17	1724323		SEAL WASHER 8
18	----		*KIT, Drain Bolt
19	1708691		O-RING 1A P10A
20	1708651		SEAL TC 153507
21	----		*SCREW, Tapping, 8 * 55
22	1707789		SCREW, Tapping, 8 * 30
24	----		*KIT, Center Case
25	1718070		PIN 3 * 9.8
26	----		*FILTER 105
27	----		*BOLT 10 * 75
28	----		*IDS VALVE 1.2
29	----		*IDS SPRING
30	----		*IDS FILTER 300
31	1725831		KIT, Cylinder Block (Pump)
32	1724290		SPRING
33	1739892		PUMP SHAFT
34	1718076		E-RING 15
35	1708673		BEARING 6202C3
36	1718077		MOTOR HOUSING
37	----		*THRUST BEARING 51106
38	----		*KIT, Cylinder Block (Motor)
39	1718074		WASHER 12 * 24 * 1
40	1724943		MOTOR SHAFT
41	1708672		SNAP RING S15
42	1724944		BRAKE DISC/MOTOR GEAR (10T)
43	1718083		BEARING 6202
44	1718089		THRUST METAL
45	----		*SWASH PLATE CMP
46	----		*THRUST BEARING (PUMP) KIT
47	----		*MAGNET HOLDER
49	----		*CONTROL SHAFT
50	1721184		FULCRUM

Footnotes:

Note* See your local authorized dealership for Tuff Torq parts and warranty or contact Tuff Torq at www.tufftorqservices.com (1-866-572-3441 US only / 01-423-585-1977)

Transmission SERVICE PARTS - Tuff Torq K46CW (1735476)

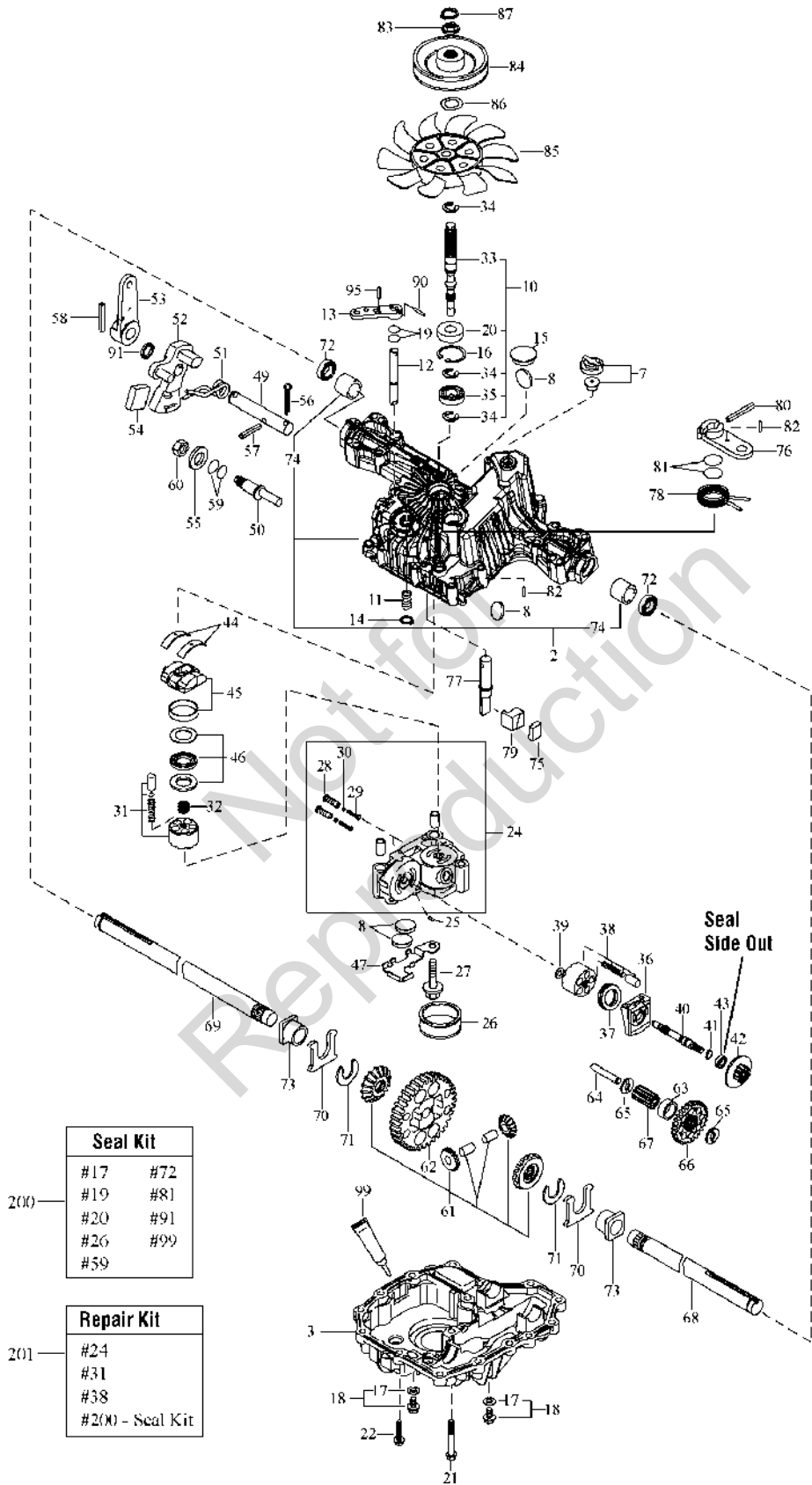

Transmission SERVICE PARTS - Tuff Torq K46CW (1735476)

Item	Part No	Qty	Description
51	----		*TORSION SPRING
52	----		*CONTROL ARM A
53	1724347		CONTORL LEVER C
54	----		*JERKY PLATE
55	----		*WASHER 12
56	----		*COTTER PIN 1/8 * 3/4
57	----		*SPRING PIN 6 * 36
58	1960588		ROLL PIN 6 * 40
59	1707879		O-RING 1A P14
60	----		*NUT 12
61	----		*KIT, Differential Gear
62	----		*FINAL GEAR (54T)
63	----		*FINAL PINION COLLAR
64	----		*REDUCTION SHAFT
65	1724948		WASHER 12 * 32 * 32
66	1724949		REDUCTION GEAR (38T)
67	----		*FINAL PINION GEAR (10T)
68	1724303		AXLE SHAFT, LEFT
69	1724304		AXLE SHAFT, RIGHT
70	1718112		THRUST WASHER
71	1718113		RING 17
72	1718111		SEAL 19 * 32 * 8
73	1718110		BUSHING 19 * 25
74	----		*BUSHING 19.05
75	1724305		BRAKE SHOE
76	1724306		BRAKE LEVER
77	----		*BRAKE SHAFT
78	----		*BRAKE RETURN SPRING
79	1724309		BRAKE ACTUATOR
80	1724310		SPRING PIN 5 * 32
81	1708690		O-RING 1A P12
82	----		*SPRING PIN 4 * 16
83	1724312		SPLINE COLLAR
84	1739893		PULLEY C
85	1724314		FAN, White
86	1724315		WASHER, Wave
87	1724316		RING, Snap
90	1707839		SPRING PIN 3.0A * 20
91	1724318		OIL SEAL 16 * 22 * .03
95	----		*SPRING PIN 3.0A * 16
99	----		*SEALANT
200	1739894		SEAL KIT (K46 & T40)
201	----		*KIT, Repair, K46 (CE,CR)

Footnotes:

Note* See your local authorized dealership for Tuff Torq parts and warranty or contact Tuff Torq at www.tufftorqservices.com (1-866-572-3441 US only / 01-423-585-1977)

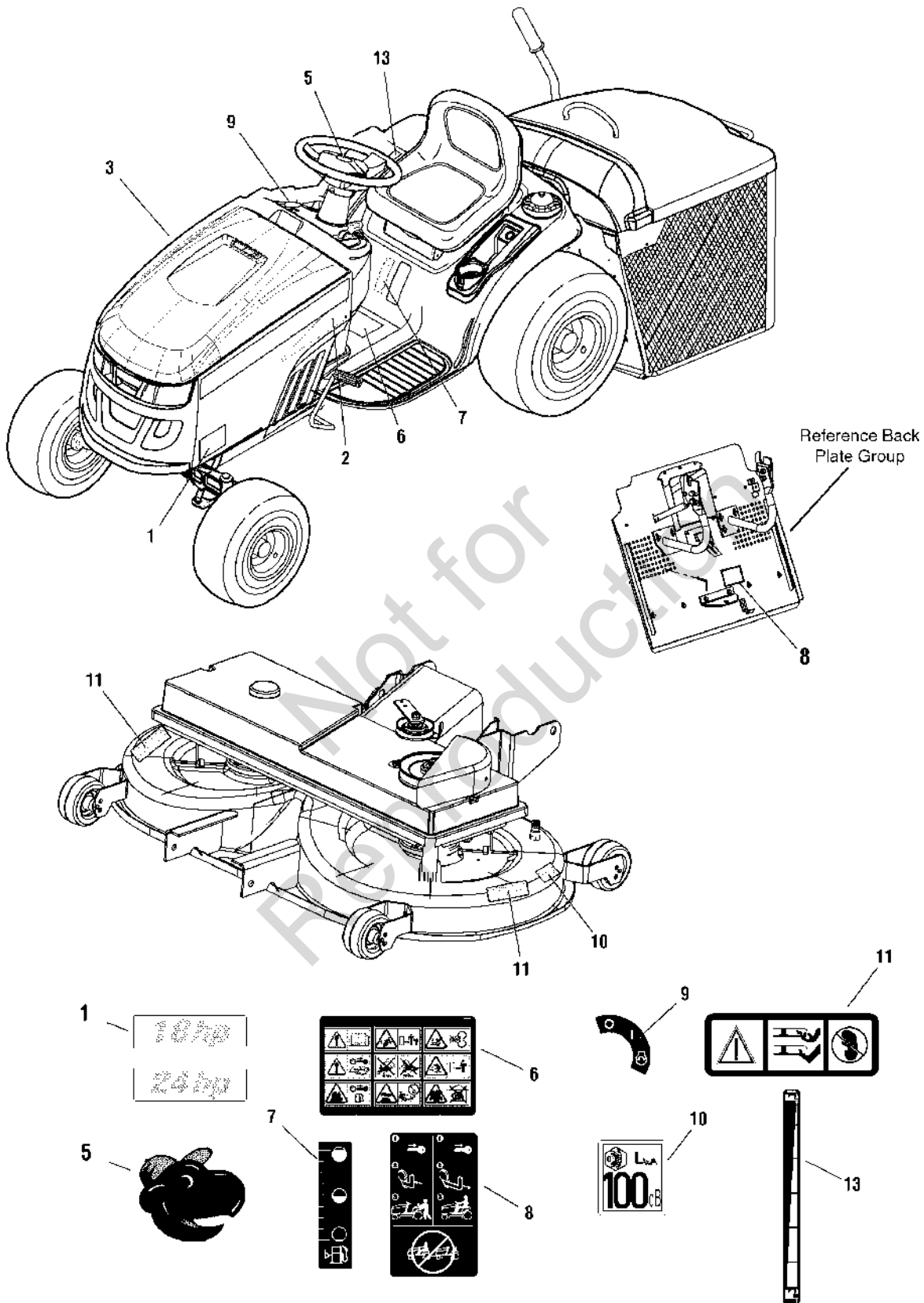

Decals Group

Item	Part No	Qty	Description
1	1739141	2	DECAL, 18HP
1	1739142	2	DECAL, 24HP
2	1731392	1	DECAL, Snapper LH Stripe
3	1731393	1	DECAL, Snapper RH Stripe
5	1731419	1	DECAL, Snapper Steering Wheel
6	1734027	1	DECAL, Tunnel
7	1735889	1	DECAL, Fuel level
8	1735265	1	DECAL, Trans/Tow Release Lever
9	1722806	1	DECAL, Ignition Switch White/Blk
10	1735891	1	DECAL, Noise
11	1735890	2	DECAL, Safety
13	1730264	1	DECAL, Mower Height

Not for
Reproduction

Footnotes:

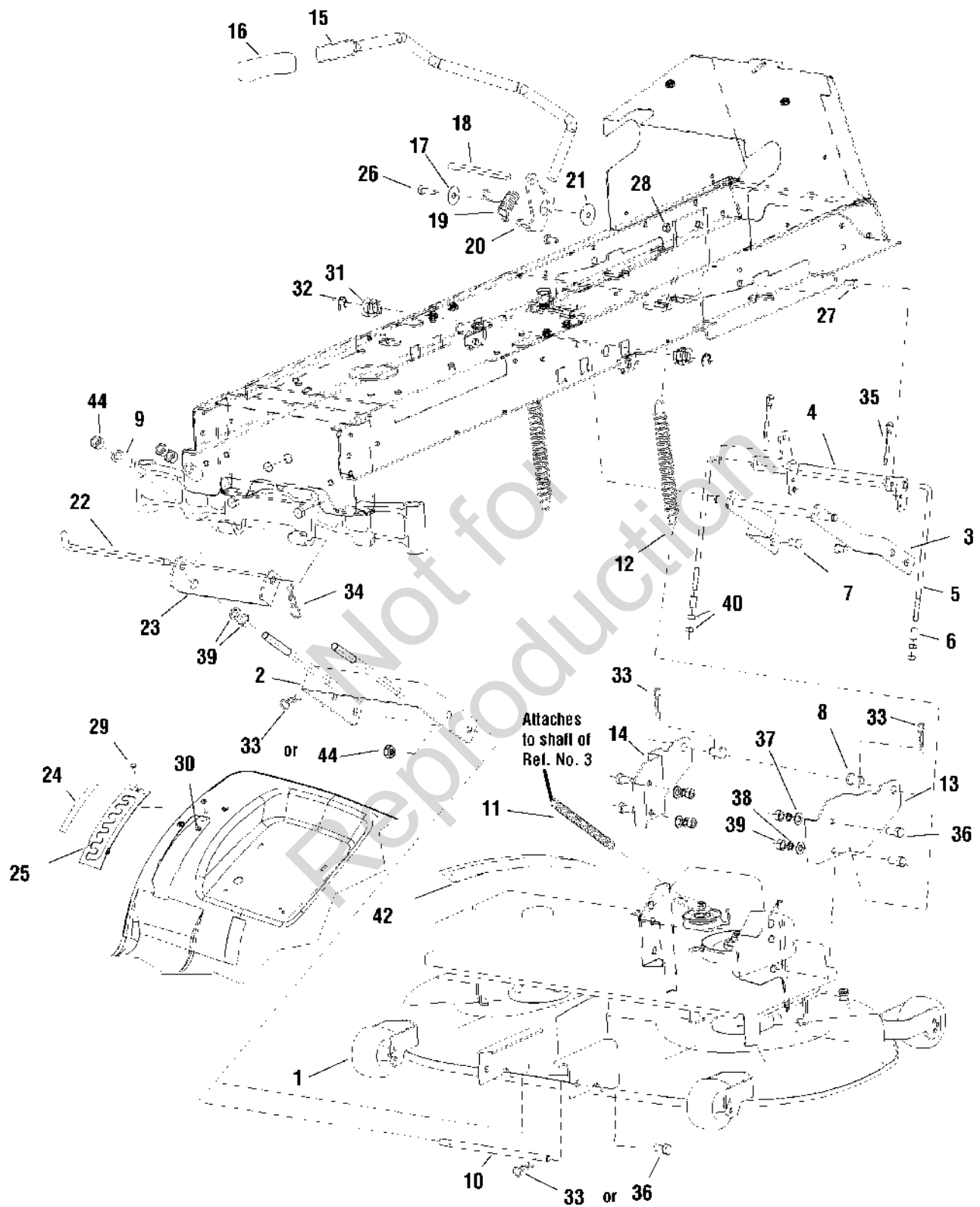

Lift Group - Manual

Item	Part No	Qty	Description
1	1735923	1	MOWING MECHANISM
2	1735902	1	HINGE, Front
3	1735848	1	ARM, Lift
4	1735958	1	ROD, Lift
5	1735979	2	TIE ROD, Lift 0-8040-311
6	1735893	2	DISTANCE, Lift 0-9521-289
7	1735945	2	PIN, 0-9016-463
8	1735947	2	PIN, Mowing 1-9310-417
9	1735895	2	DISTANCE, Lift Hitch 0-9521-290
10	1735944	1	STUD Used on models before serial number 2013642213)
11	1735825	1	SPRING, 0-9746-460
12	1735967	2	SPRING, 0-9746-483
13	1735898	1	HANDLE, Extend, Left
14	1735899	1	HANDLE, Extend, Right
15	1735956	1	ROD, Lift
16	1722302	1	GRIP, Black
17	1960044	1	WASHER, 5/16
18	1727954	1	ROD, Lift 3/8 dia
19	1729652	1	SPRING, Torsion
20	1728990	1	CLEVIS, Lift
21	1727935	1	SPACER, Pivot
22	1731414	1	PIN, Hitch
23	1730221A	1	HANGER, Front
24	1730264	1	DECAL, Height of Cut
25	1727985	1	QUADRANT, Lift Height
26	1921333	1	CAPSCREW, Hex Head, 5/16-18 x 1
27	1930601	2	CAPSCREW, Hex Head, 5/16-18 x 5/8
28	1931277	1	NUT, Hex Flange Lock, 5/16-18
29	1960252	1	BOLT, Carriage, 1/4-20 x 5/8
30	1930641	1	NUT, Hex Flange Whiz, 1/4-20
31	1735881	2	BUSHING, 0-9462-202
32	1735920	2	LOCK RING, 12
33	1735965	4	PIN, Flexible 0-9245-240 Used on models before serial number 2013642213)
34	2176012	1	CLIP, Pin Safety
35	1735964	4	SPINDLE
36	1735856	4	BOLT, M12 x 25 Used on models after serial number 2013642213)
37	1735993	4	WASHER, 13
38	1735992	4	WASHER, 12
39	1735927	8	NUT, M12
40	1735925	4	NUT, M10
42	1735986	1	V-BELT, Li, BBT, 17 x 1200
44	1735796	4	NUT, M12 Used on models after serial number 2013642213)

Footnotes:

40" Mower Deck - Belt & Idler Arm Group

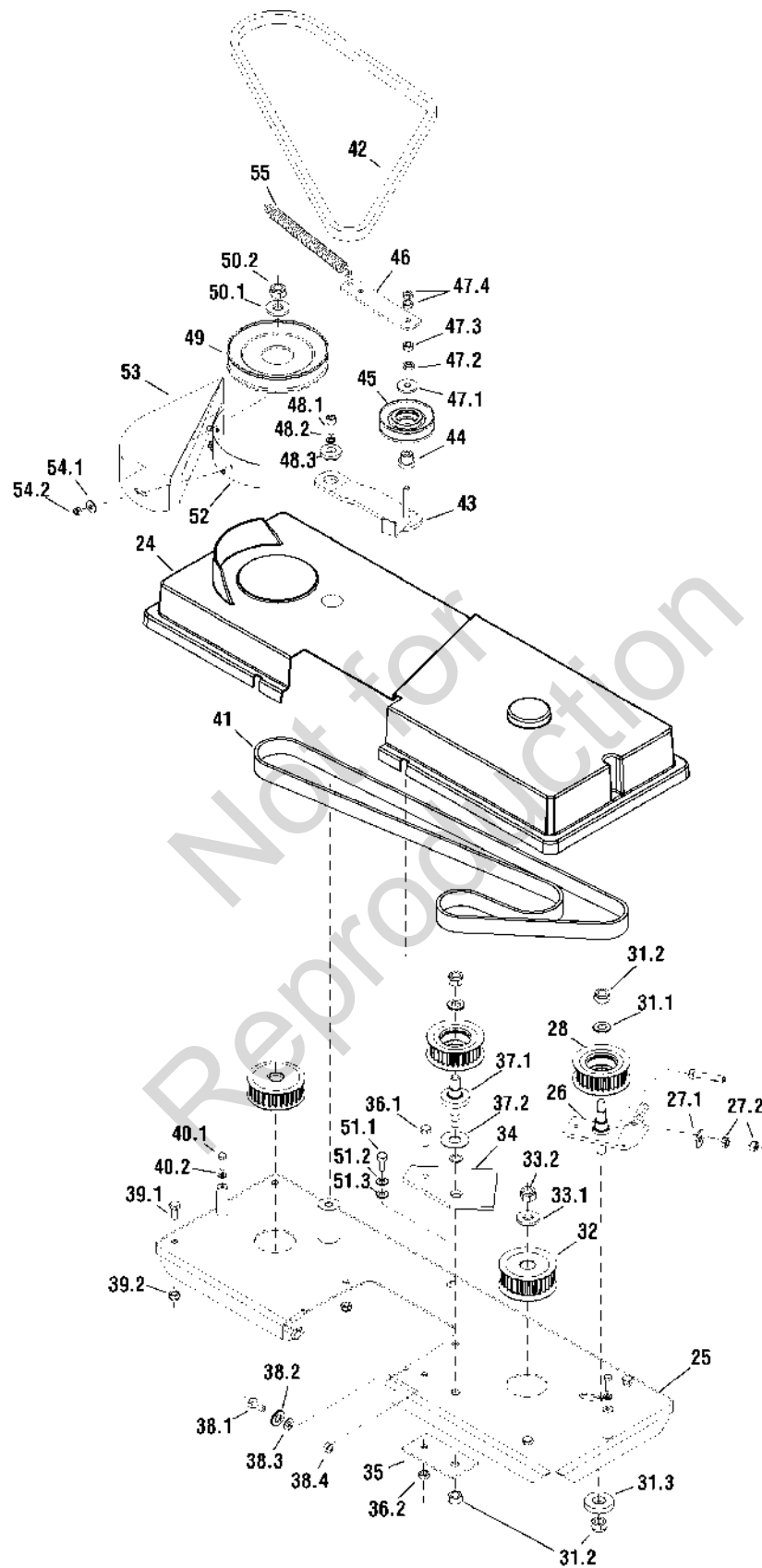

40" Mower Deck - Belt & Idler Arm Group

Item	Part No	Qty	Description
24	1735802	1	COVER, Plastic 0-8547-369
25	1735794	1	MAIN BOARD
26	1735787	1	FOOTING, Complete
27.1	1735846	1	WASHER, Zinc, 9
27.2	1735799	2	NUT, M8
28	1735781	1	PULLEY, Belt, 28 Z
31.1	1735837	2	WASHER, 13
31.2	1735796	4	NUT, M12
31.3	1735842	1	WASHER
32	1735784	2	PULLEY
33.1	1735834	1	WASHER, 0-9220-727
33.2	1735796	1	NUT, M12
34	1735804	1	REINFORCEMENT
35	1735805	1	REINFORCEMENT
36.1	1735818	1	SCREW, M8 x 25
36.2	1735801	1	NUT, M8
37.1	1735827	1	STUD
37.2	1735841	1	WASHER
38.1	1735843	2	SCREW, Zinc, M8 x 20
38.2	1735837	2	WASHER, 13
38.3	1735839	2	WASHER, 8.4
38.4	1735801	2	NUT, M8
39.1	1735820	6	SCREW, M8 x 40
39.2	1735801	6	NUT, M8
40.1	1735816	2	SCREW, M6 x 20
40.2	1735844	6	WASHER, Zinc, 6.6
41	1735832	1	BELT, Two Side Toothed, K+K20DS 1760
42	1735986	1	V-BELT, Li, BBT, 17 x 1200
43	1735790	1	HOLDER, Complete
44	1735826	1	STUD, 0-9321-263
45	1735811	1	ROLLER, W 3500-3712
46	1735788	1	FOOTING
47.1	1735845	1	WASHER, Zinc, 9
47.2	1735838	1	WASHER, 8
47.3	1735799	1	NUT, M8
47.4	1735800	2	NUT, M8
48.1	1735817	1	SCREW, M8 x 20 10.9 ZN DIN 912
48.2	1735838	1	WASHER, 8
48.3	1735836	1	WASHER, 0-9221-222
49	1735782	1	BELT, Pulley, 9-3325-234, Complete
50.1	1735834	1	WASHER, 0-9220-727
50.2	1735796	1	NUT, M12

Footnotes:

40" Mower Deck - Belt & Idler Arm Group

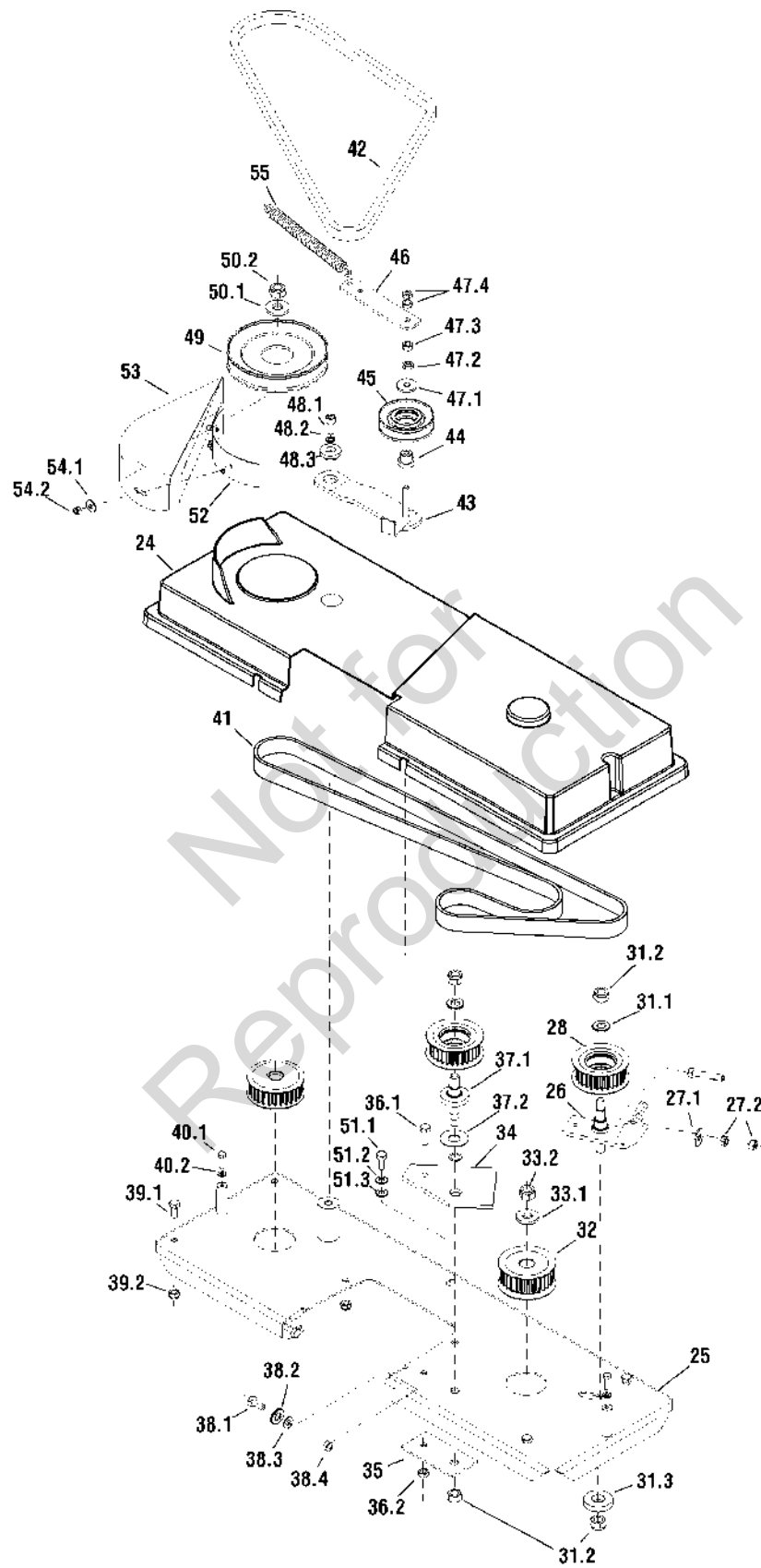

40" Mower Deck - Belt & Idler Arm Group

Item	Part No	Qty	Description
51.1	1735820	1	SCREW, M8 x 40
51.2	1735838	1	WASHER, 8
51.3	1735839	1	WASHER, 8.4
52	1735806	1	REINFORCEMENT
53	1735783	1	COVER, Belt Pulley 0-8534-203
54.1	1735844	2	WASHER, Zinc, 6.6
54.2	1735798	2	NUT, M6
55	1735825	1	SPRING, 0-9746-460

Not for
Reproduction

Footnotes:

40" Mower Deck - Housing, Hitch, Arbors & Blades Group

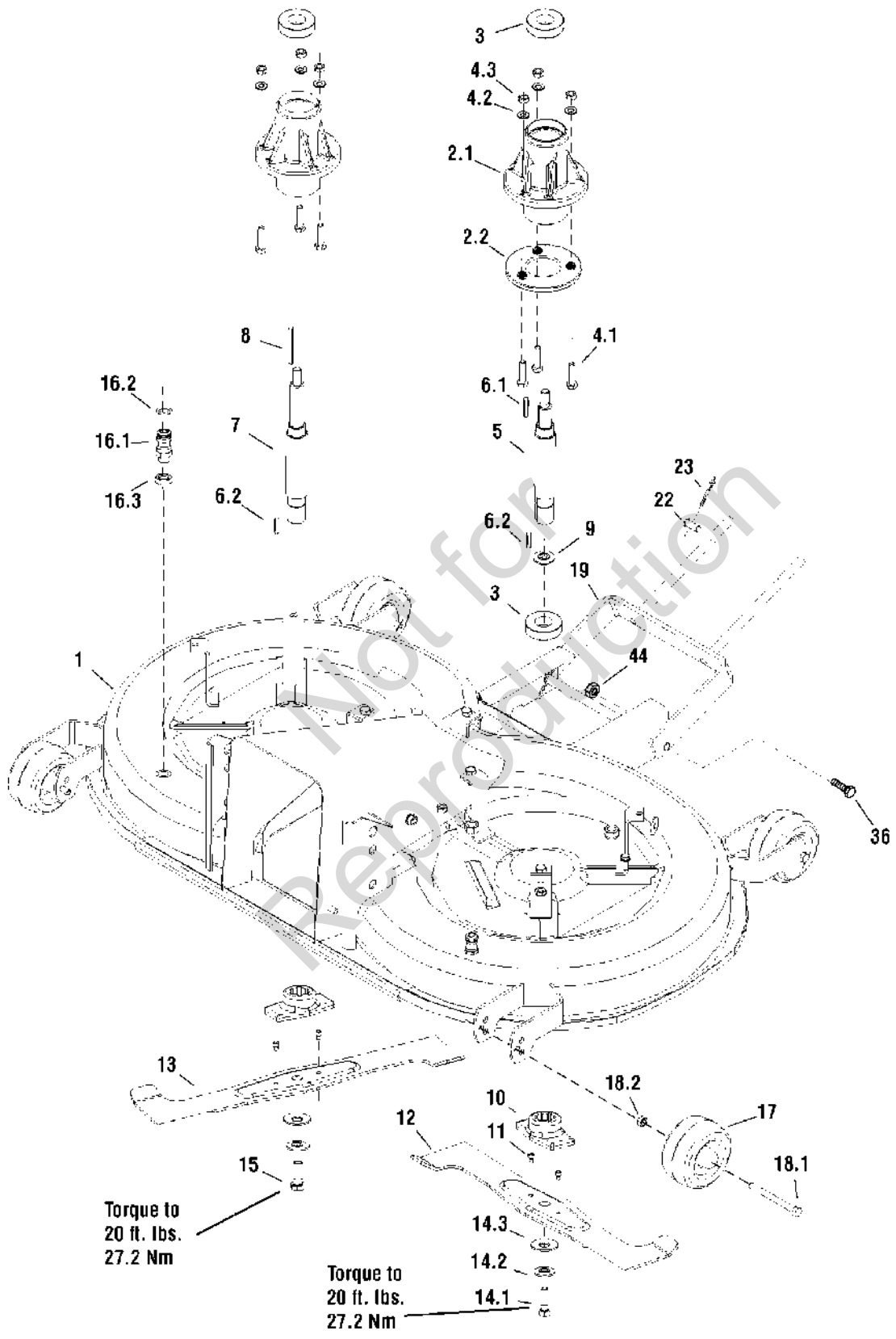

40" Mower Deck - Housing, Hitch, Arbors & Blades Group

Item	Part No	Qty	Description
1	1735888	1	COVER, Cutting Knife, Complete
2.1	1735791	2	HOUSING
2.2	1735807	2	REINFORCEMENT
3	1735780	4	BEARING, 6205 2 RS C 661B
4.1	1735819	6	SCREW, M8 x 35
4.2	1735839	6	WASHER, 8.4
4.3	1735801	6	NUT, M8
5	1735823	1	SHAFT
6.1	1735830	1	TONGUE, 6 H 9 x 6 x 30
6.2	1735829	2	TONGUE, 6 H 9 x 6 x 25
7	1735822	1	SHAFT
8	1735831	1	TONGUE, 6 H 9 x 6 x 63
9	1735812	2	RING, Safety, 25
10	1735792	2	HOUSING
11	1735824	4	SHEAR, STUD 0-9311-736
12	1735809	1	CUTTING KNIFE, Rotary, Right
13	1735793	1	CUTTING KNIFE, Rotary, Left
14.1	1735815	1	SCREW, 0-9011-287, M10
14.2	1735835	2	WASHER, 0-9220-749
14.3	1735840	2	WASHER, BN 806-40 x 16.3 x 2 x 3.1
15	1735814	1	SCREW, 0-9011-283 M10, Left Thread
16.1	1735803	2	QUICK FASTENER, 0-9026-246
16.2	1735810	2	RING, 13 x 2 NBR
16.3	1735797	2	NUT, M12
17	1735808	4	CUTTING WHEEL, Right ETOP 100-8,2
18.1	1735821	4	SCREW, M8 x 90
18.2	1735801	4	NUT, M8
19	1735902	1	HINGE, Front
20	1735944	1	STUD (Used before serial number 2013642213)
21	1735965	4	PIN, Flexible, 0-9245-240 (Used before serial number 2013642213)
22	1735795	2	MOWING STUD, 1-9310-290
23	1735786	4	PIN, Flexible, 0-9245-999
36	1735856	2	BOLT, M12 x 25 (Used after serial number 2013642213)
44	1735796	2	NUT, M12 (Used after serial number 2013642213)

Footnotes:

Back Plate Group - 18HP & 24HP

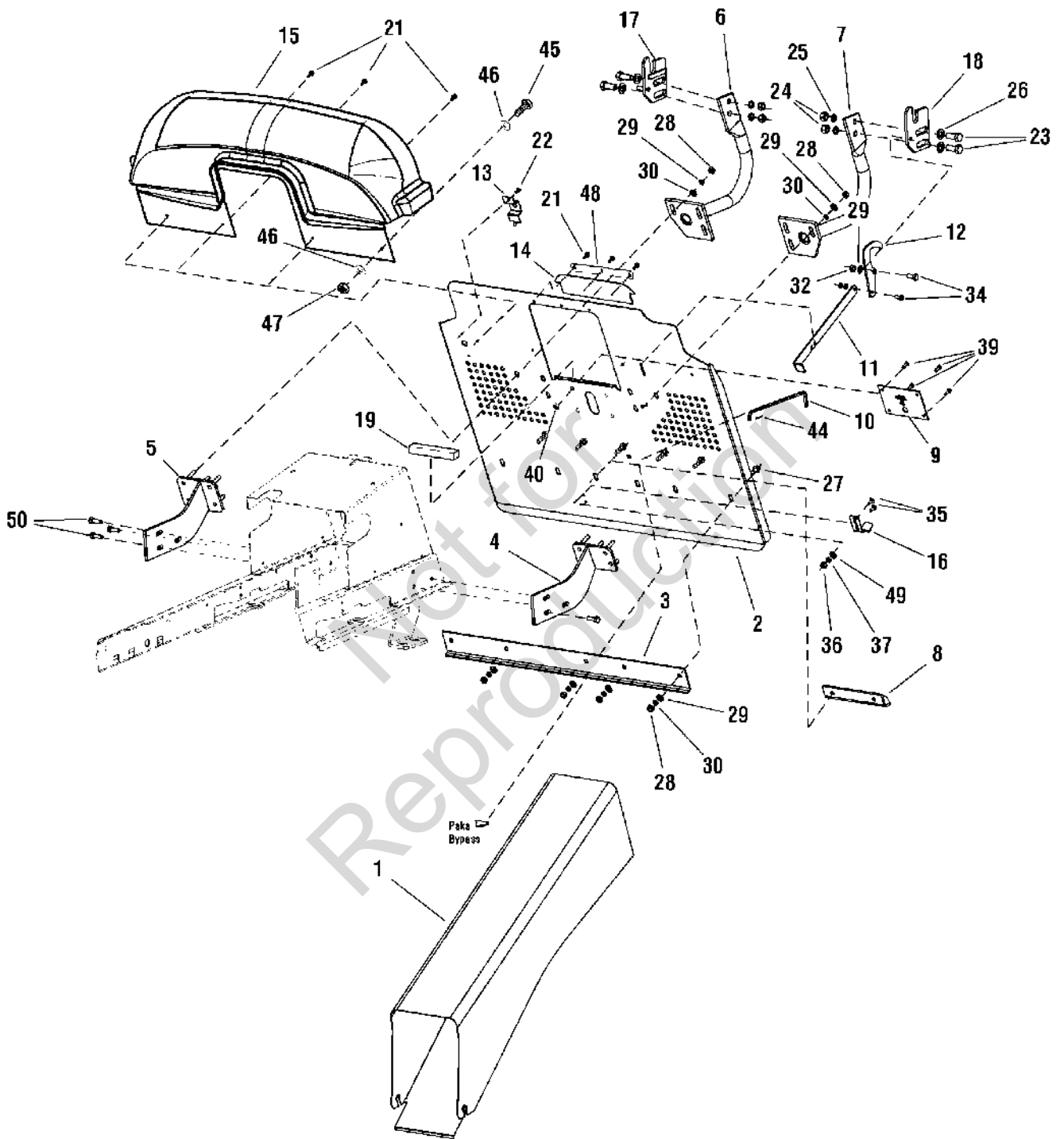

Back Plate Group - 18HP & 24HP

Item	Part No	Qty	Description
1	1735985	1	TUNNEL
2	1735849	1	BACK PLATE
3	1735876	1	BRACE
4	1735906	1	HOLDER, Back Plate, L.H.
5	1735907	1	HOLDER, Back Plate, R.H.
6	1735908	1	HOLDER, Collector, R.H.
7	1735909	1	HOLDER, Collector, L.H.
8	1735903	1	HITCH
9	1735975	1	SWITCH, Full Collector
10	1735977	1	TIE ROD, Bypass 0-8045-260
11	1735978	1	LATCH, Tie Rod
12	1735915	1	LATCH
13	1735887	1	COVER, Switch
14	1735939	1	PAD, Rubber 1-1332-332
15	1735983	1	COVER, Plastic
16	1735970	1	SPRING COLLECTOR, Lock
17	1735904	1	HOLDER, Adjustable, Right
18	1735905	1	HOLDER, Adjustable, Left
19	1736998	1	RUBBER EDGE
21	1735961	6	SCREW, ST 5.5 x 19 DIN 7504-K BN1880
22	1735960	1	SCREW, ST 4.2 x 9.5 DIN 7504-K BN1880
23	1735857	4	BOLT, M12 x 30
24	1735927	4	NUT, M12
25	1735993	4	WASHER, 13
26	1735992	4	WASHER, 12
27	1735871	10	BOLT, M8 x 25 DIN 6921 8.8
28	1735934	12	NUT, M8
29	1735989	19	WASHER, 8.4
30	1736000	12	WASHER, 8
32	1735935	7	NUT, M8
34	1735868	1	BOLT, M8 x 40
35	1735860	2	BOLT, M5 x 16
36	1735930	2	NUT, M5
37	1735997	2	WASHER, 5.3
39	1735861	4	BOLT, M5 x 16
40	1735931	4	NUT, M5
44	1735963	1	SPINDLE, 2 x 20
45	1735858	1	BOLT, M4 x 16
46	1735995	2	WASHER, 4.3
47	1735929	1	NUT, M4
48	1739133	1	PAD, Steel
49	1739134	2	WASHER, 8.4
50	1930601	6	CAPSCREW, Hex Washer Head, Tapitite, 5/16-18 x 5/8

Footnotes:

Rear Discharge Deflector Group

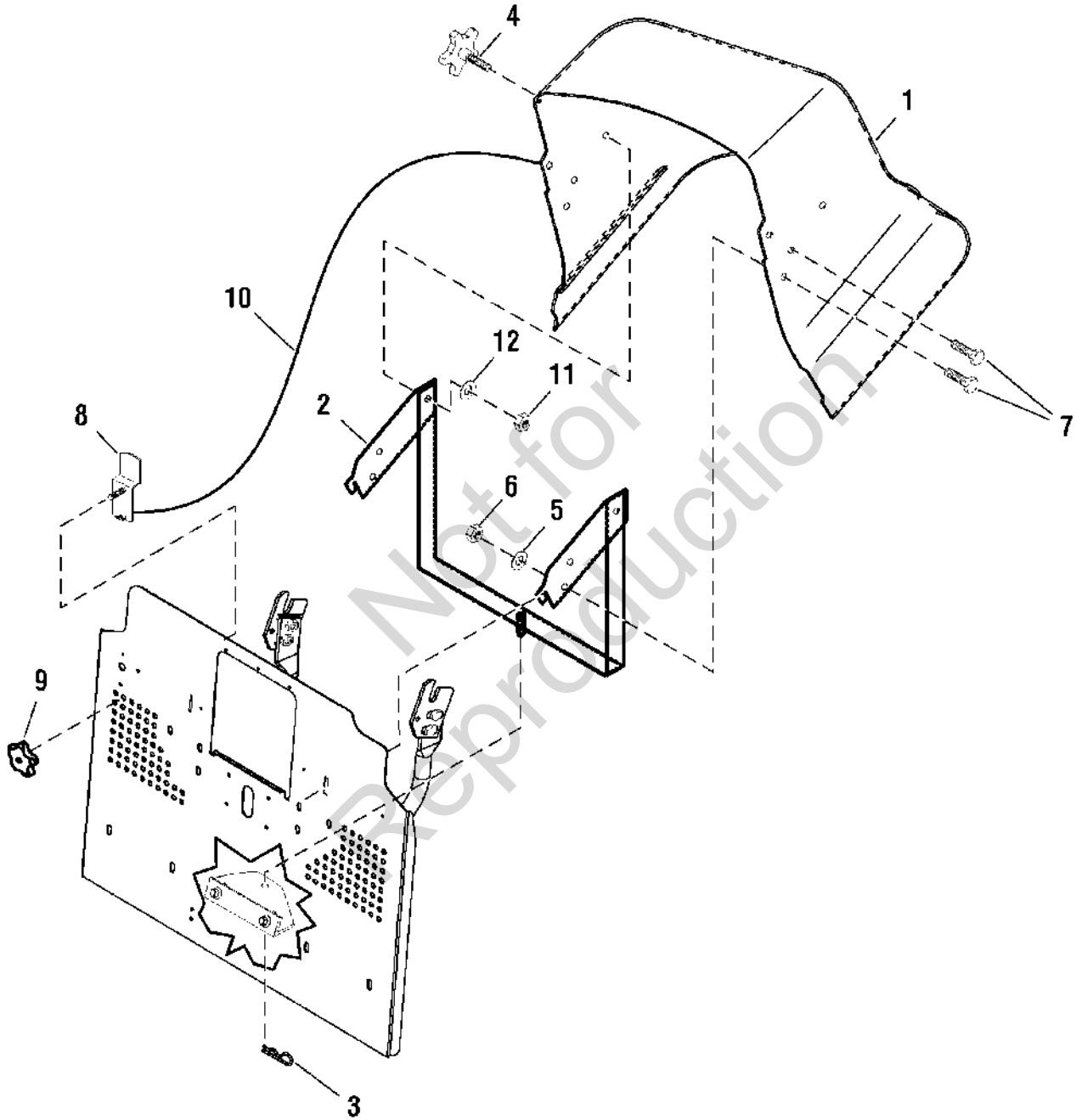

Rear Discharge Deflector Group

Item	Part No	Qty	Description
--	1687401	1	DEFLECTOR, Complete
1	1739710	1	DEFLECTOR
2	1739711	1	DEFLECTOR HOLDER
3	1739716	1	HAIR PIN
4	1739712	2	SCREW, With Starlike Knob
5	1735998	4	WASHER, 6.4
6	1736127	4	NUT, Selflock, M6
7	1732635	4	SCREW, Flat Head, M6x16
8	1739713	1	BAND
9	1739714	1	NUT, With Starlike Knob
10	1739715	1	CORD, Hair Line, 550mm
11	1735935	2	NUT, M8
12	1735989	2	WASHER, 8.4

Not for
Reproduction

Footnotes:

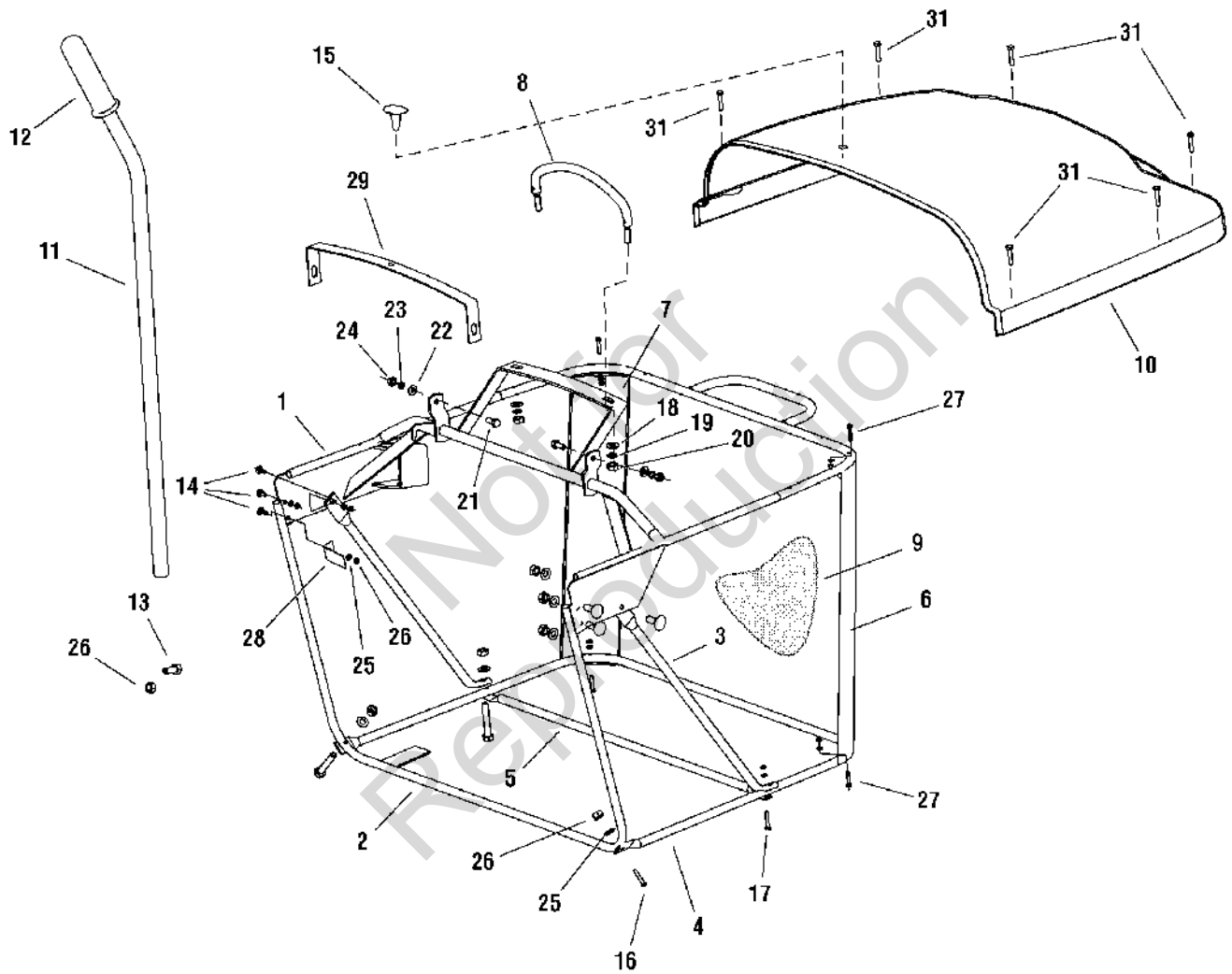

Collector Group

Item	Part No	Qty	Description
--	1737791	1	CATCHER ASSEMBLY (Includes Ref Nos: 1 - 30)
1	1735897	1	FRAME, Top
2	1736463	1	TUBE, Front
3	1735877	2	BRACE
4	1735984	1	TUBE, Bottom
5	1735953	1	TUBE, Connecting
6	1736236	1	REINFORCEMENT, Left
7	1735954	1	REINFORCEMENT, Right
8	1735900	1	HANDLE, Full
9	1735885	1	COAT, Fabric
10	1735982D	1	TOP, Collector 0-7447-260
11	1735916	1	LEVER, Dumping
12	1735901	1	HANDLE, Rubber RC/M 25
13	1735859	1	BOLT, M5 x 12
14	1735860	6	BOLT, M5 x 16
15	1735948	1	PLUG, Plastic
16	1735863	2	BOLT, M5 x 30
17	1735864	2	BOLT, M5 x 35
18	1735990	2	WASHER, 10.5
19	1735991	2	WASHER, Lock 10
20	1735925	2	NUT, M10
21	1735868	2	BOLT, M8 x 20
22	1735989	2	WASHER, 8.4
23	1736000	2	WASHER, Lock 8
24	1735934	2	NUT, M8
25	1735997	14	WASHER, 5.3
26	1735931	15	NUT, M5
27	1735862	4	BOLT, M5 x 25
28	1735971	1	SPRING, Flat
29	1735955	1	REINFORCEMENT, Top
31	1736416	6	SCREW, 6.3 x 32 DIN 7504-K

Footnotes:

Mulching Flap Group

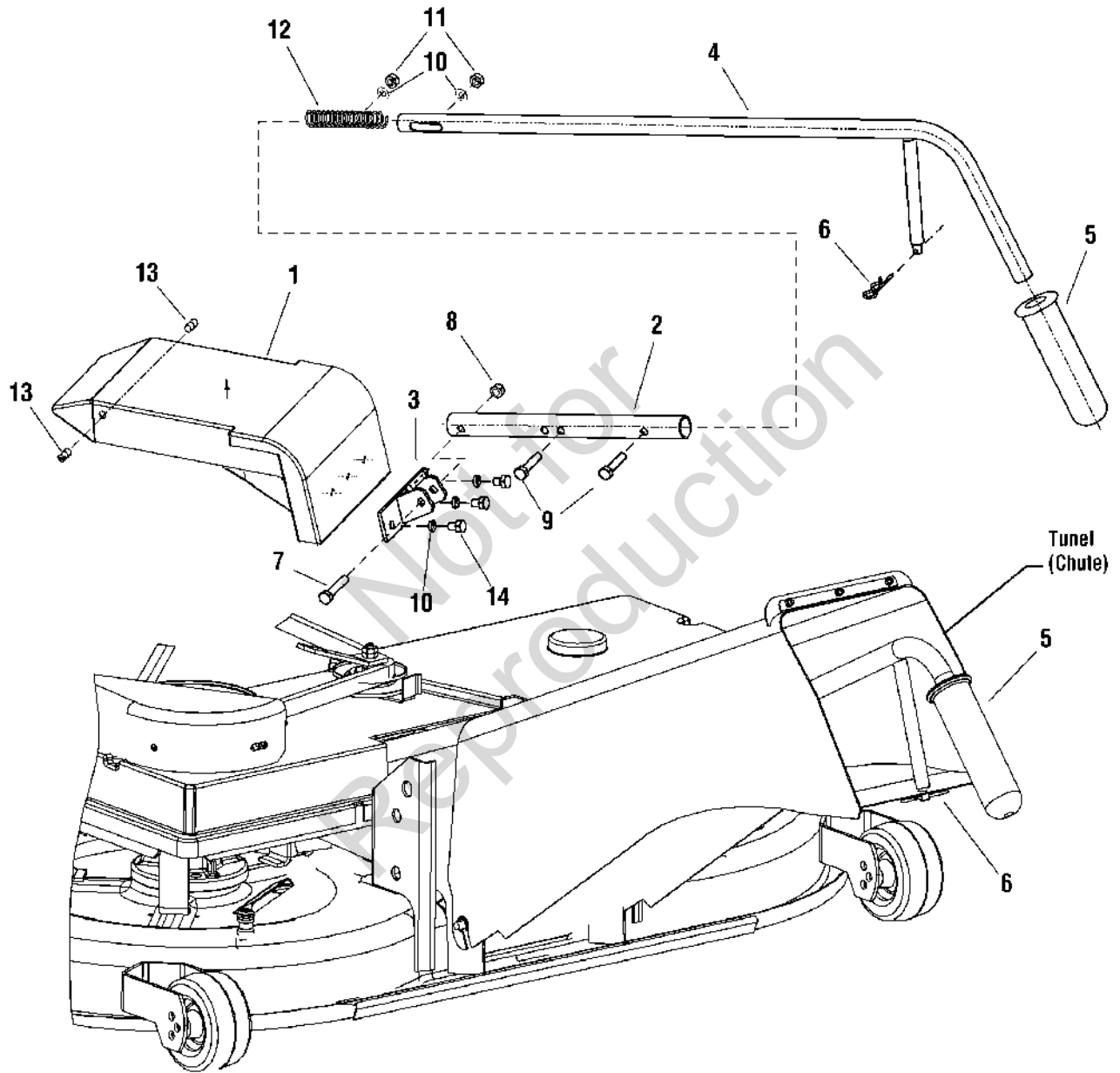

Mulching Flap Group

Item	Part No	Qty	Description
--	1687401	1	MULCH PLUG ASSEMBLY, Complete (Includes Ref. Nos. 1-14)
1	1736134	1	MOWING FLANGE, 9-8547-386
2	1736133	1	TUBE
3	1736132	1	HOLDER
4	1736131	1	FULL TUBE
5	1736130	1	HANDLE, 02/20-110-RED
6	1736129	1	SPLIT PIN, 0-9245-24
7	1736128	1	SCREW, M8 x 45 CSN021103.55
8	1736127	1	NUT, M8 CSN021492.55
9	1736126	2	SCREW, M8 x 35 CSN021103.55
10	1736125	5	WASHER, 8 CSN021740.15
11	1736124	2	NUT, M8 CSN021401.55
12	1736123	1	SPRING, TLZ200.180.0950
13	1736122	2	CASING, 0-9311-816
14	1736121	3	SCREW, M8 x 12 CSN021103.25

Not for
Reproduction

Footnotes:

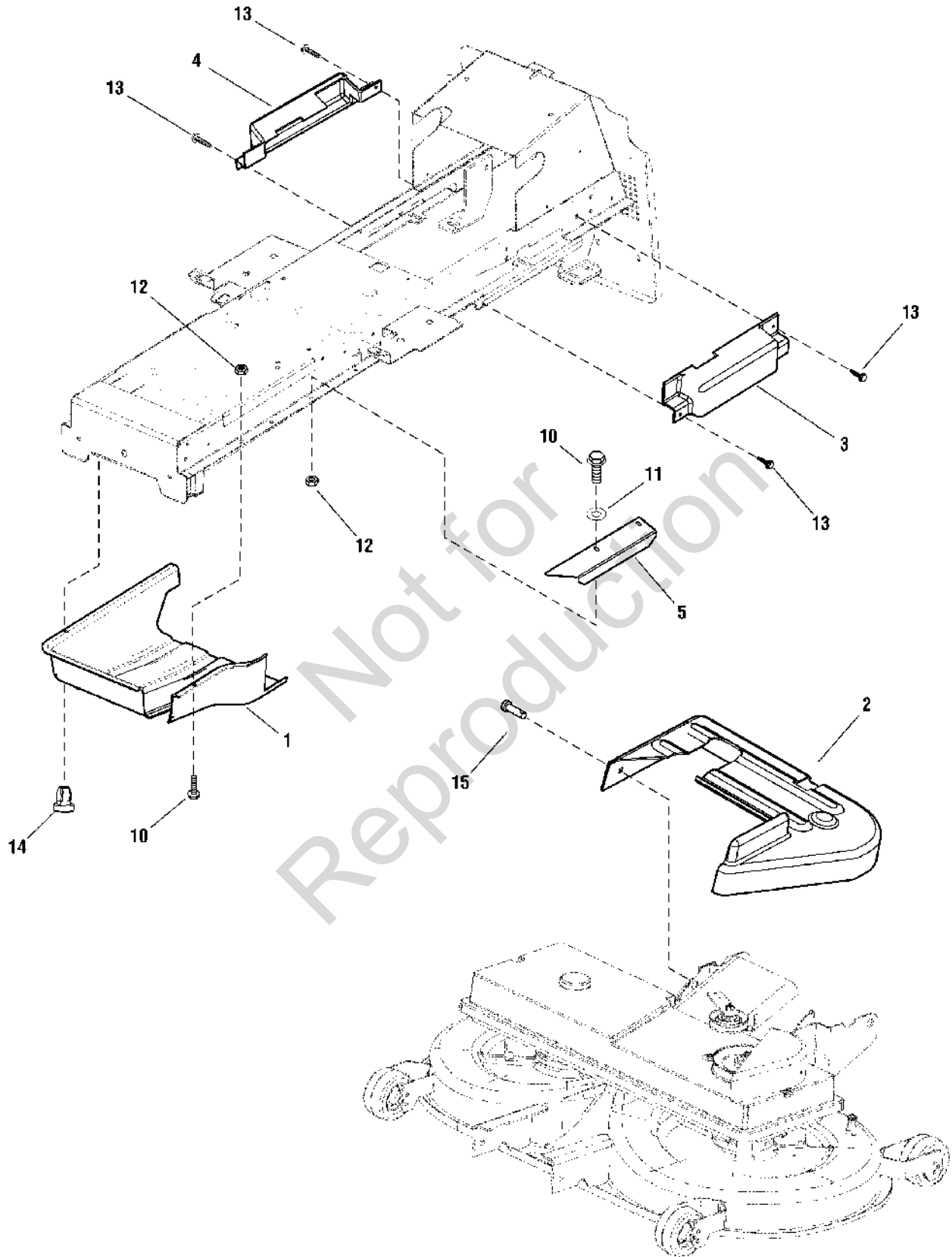

French Guard Group

Item	Part No	Qty	Description
1	1737360	1	COVER, Clutch
2	1737361	1	COVER, Mower Deck
3	1737362	1	COVER, Roller, Left
4	1737363	1	COVER, Roller, Right
5	1737364	1	COVER, Side
10	1735859	6	SCREW, M5 x 12
11	1735997	2	WASHER
12	1735931	6	NUT, M5
13	1735961	4	SCREW, ST, 5.5 x 19
14	1737365	2	HOUSING
15	1737366	2	PIN

Not for
Reproduction

Footnotes:

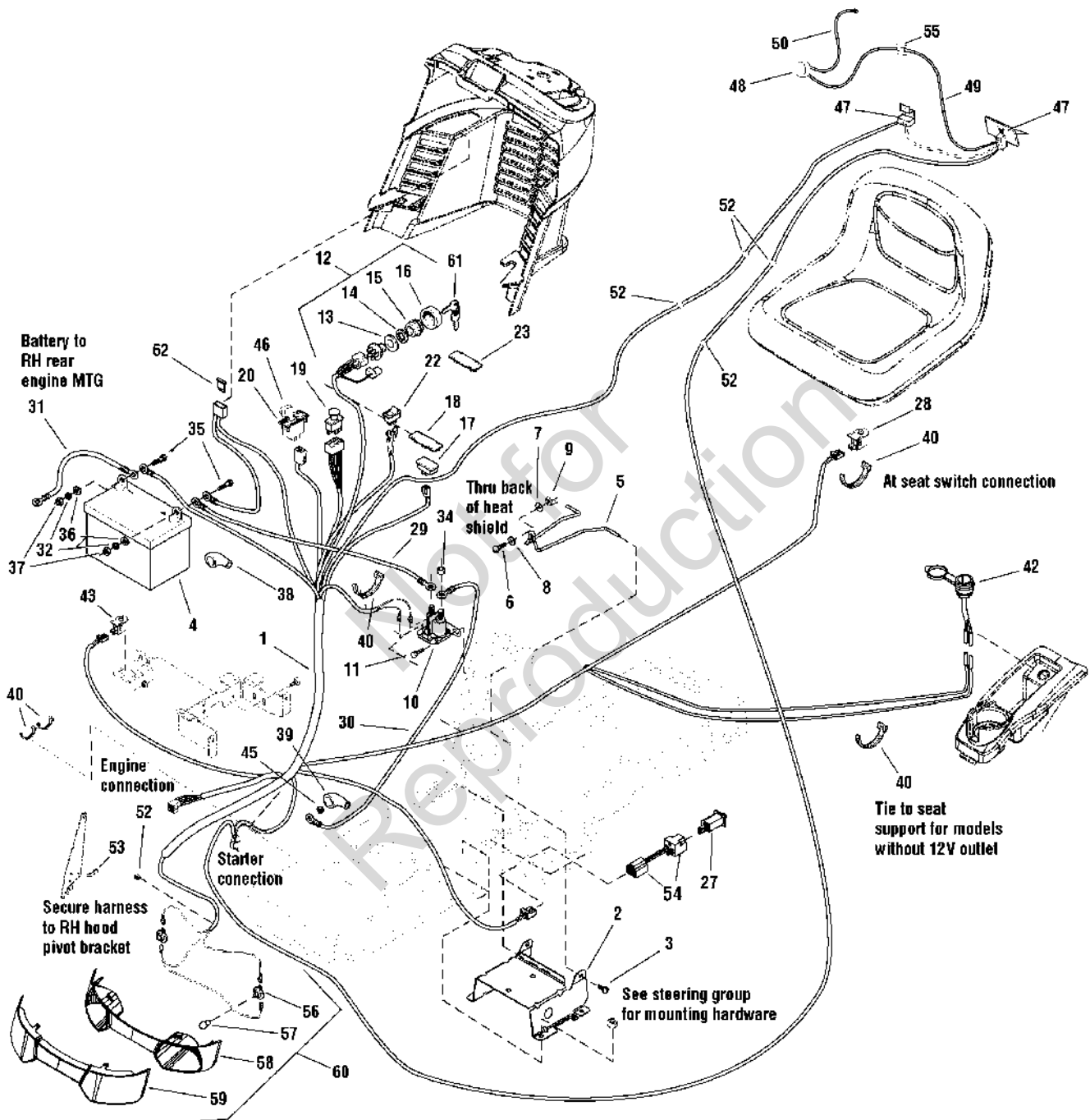

Electrical Group - 18HP & 24HP

Item	Part No	Qty	Description
1	1735475	1	HARNESS, Main
2	1727282	1	SUPPORT, Battery
3	1930601	4	SCREW, Hex Washer Head, TAPTITE, 5/16-18 x 5/8
4	1685215	1	BATTERY, 12V 230 CCA DRY
5	1730007	1	HOLD DOWN, Battery
6	1931318	1	BOLT, Carriage, 1/4-20 x 7/8
7	1960353	1	WASHER, Flat .25
8	1960518	1	PUSHNUT, 1/4
9	1920397	1	NUT, 1/4 ESNA
10	1728963	1	SOLENOID, 12V
11	1925003	2	SCREW, Hex Washer Head, TAPTITE, 1/4-20 x 1/2
12	1716061	1	SWITCH ASSEMBLY, Ignition (Includes Ref. Nos. 13, 14, 15 & 16)
13	2101025	1	WASHER, 5/8
14	1960547	1	WASHER, Lock, Int. Tooth .62
15	1717549	1	NUT, Hex Flange, 5/8, IGN Switch
16	1717550	1	COVER, Ignition Switch
17	1728068	1	HOUR METER (24HP)
18	1729993	1	PLUG, Hour Meter (18HP)
19	1722887	1	SWITCH, PTO
20	1726556	1	SWITCH, RMO Module
22	1716951	1	SWITCH, Head lights
23	1722611	1	PLUG
27	1732006	1	SWITCH, Push (Foot Pedal)
28	1732005	1	SWITCH, Push NC (Seat)
29	1716549	1	CABLE, #6 10.0 Lg Red
30	1721830	1	CABLE, #6 25.0 Lg Red
31	1713163	1	CABLE, #6 20.0 Lg Black
32	2816964	2	LOCKWASHER, Spring 1/4
34	2860750	2	NUT, Hex KEPS Lock, 5/16-24
35	2823341	2	CAPSCREW, Hex, 1/4-20 x 3/4
36	2821319	2	WASHER, Flat, 1/4
37	2816622	2	NUT, Hex, 1/4-20
38	1677296	1	BOOT, Insulator, Battery
39	1713535	1	BOOT, Insulator, Red
40	1735980	5	TIE, RT 360 /L=150
42	7073090	1	12V AUX. PLUG, With Cover
43	1732004	1	SWITCH, NO (RMO)
45	1960294	1	NUT, Flange, Whiz, 1/4-20
46	1726557	1	KEY, RMO Module
47	1735922	2	MICROSWITCH, MKH 12 D13 S1
48	1735852	1	BEEPER, PF 27 A 29 EP/
49	1736003	1	WIRE, 9-8316-616
50	1736002	1	WIRE, 9-8316-615
52	1735882	7	CABLE, Clip WSBH 1-0-1

Footnotes:

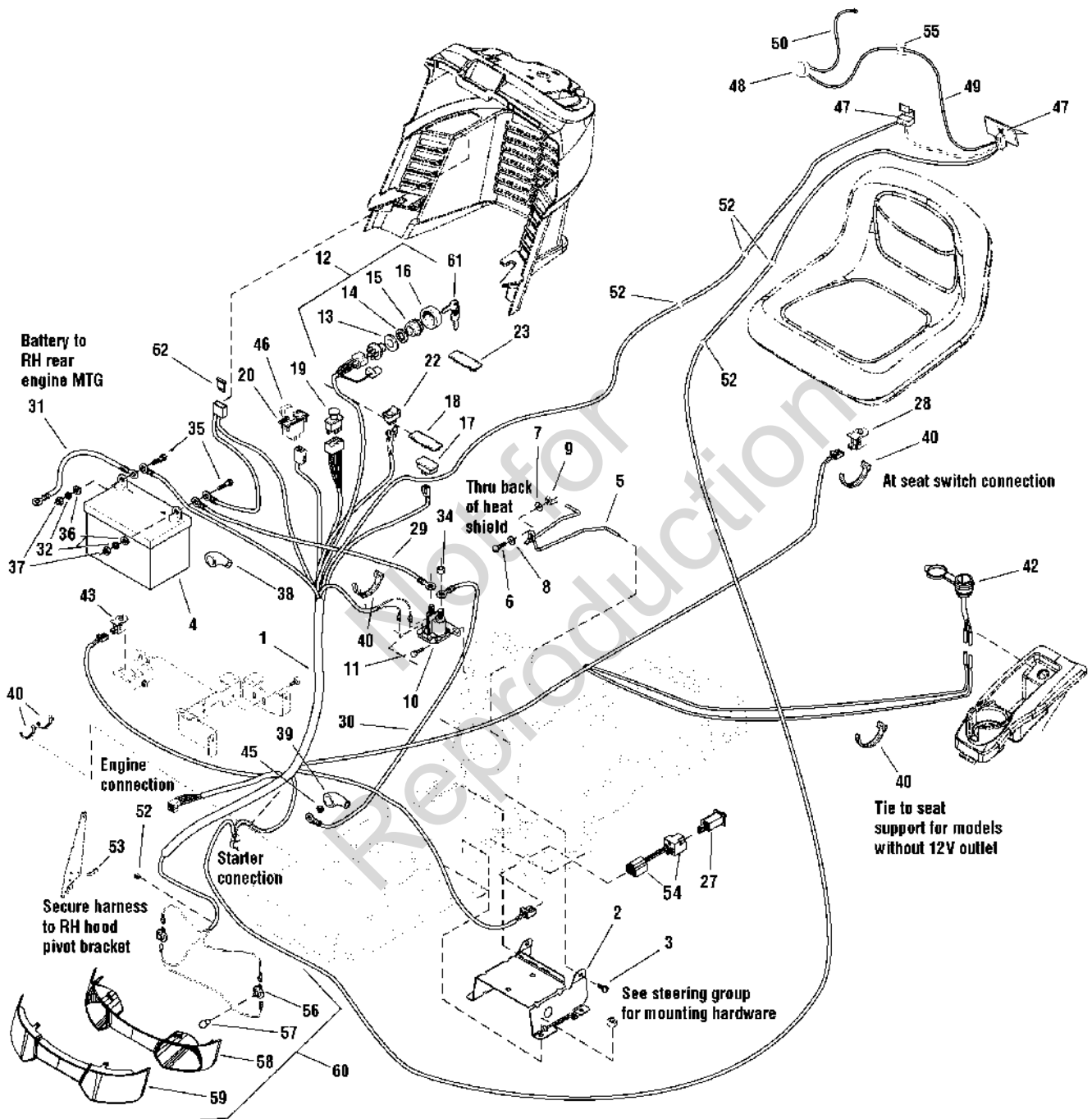

Electrical Group - 18HP & 24HP

Item	Part No	Qty	Description
53	2834683	1	CLIP, Speed Wire
54	1734025	1	PLUG, Shut-Off
55	1735884	1	CLIP, Cable WCK 460 01/A
56	1723451	2	SOCKET ASSEMBLY
57	1677371	2	BULB, 1141-12V 21CP
58	1728973	1	REFLECTOR, Headlight
59	1728974	1	LENS, Headlight
60	1727296	1	HEADLIGHT ASSEMBLY (Includes Ref. Nos. 56, 57, 58 & 59)
61	1717163	1	KEY, Ignition (Set of 2)
62	1731957	1	FUSE

Not for
Reproduction

Footnotes:

Not for
Reproduction

Not for
Reproduction

Not for
Reproduction

Hardware Identification & Torque Specifications

Torque Specification Chart								
FOR STANDARD METRIC MACHINE HARDWARE (Tolerance ± 20%)								
Property Class	5.6		8.8		10.9		12.9	
	Class 5.6		Class 8.8		Class 10.9		Class 12.9	
Size Of Hardware	in/lbs		in/lbs		in/lbs		in/lbs	
	ft/lbs	Nm.	ft/lbs	Nm.	ft/lbs	Nm.	ft/lbs	Nm.
M3	5.88	.56	13.44	1.28	19.2	1.80	22.92	2.15
M4	13.44	1.28	30.72	2.90	43.44	4.10	52.56	4.95
M5	26.4	2.50	60.96	5.75	5.97	8.10	7.15	9.7
M6	44.64	4.3	7.3	9.9	10.3	14	12.1	16.5
M7	5.2	7.1	12.1	16.5	16.9	23	19.9	27
M8	7.7	10.5	17.7	24	25	34	29	40
M10	15	21	35	48	50	67	59	81
M12	26	36	61	83	86.2	117	103	140
M14	42	58	101	132	136	185	162	220
M16	64	88	147	200	210	285	250	340
M18	89	121	202	275	287	390	346	470
M20	126	171	290	390	405	550	486	660
M22	169	230	390	530	559	745	656	890
M24	217	295	497	375	708	960	840	1140
M27	320	435	733	995	1032	1400	1239	1680
M30	435	590	995	1350	1401	1900	1681	2280
M33	590	800	1349	1830	1902	2580	2278	3090
M36	759	1030	1740	2360	2441	3310	2935	3980
M39	988	1340	2249	3050	3163	4290	3798	5150

The guides and ruler furnished below are designed to help you select the appropriate hardware.

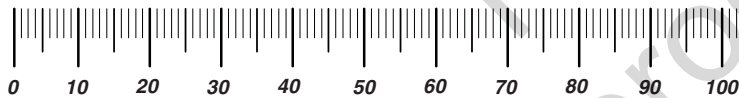

Nut, M8

Thread Diameter (mm)
Inside Diameter (in)
Threads per inch

Nut, 1/2-16

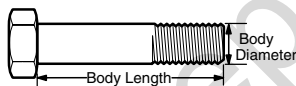

Screw, M8- 1.25 x 25

Thread Diameter (mm)
Body Diameter
Distance between threads (mm)
Threads per inch
Body Length (mm)
Body Length (in)

Screw, 1/2- 16 x 2

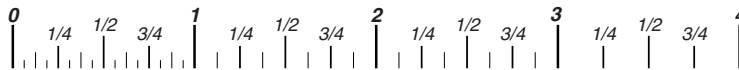

Standard Hardware Sizing

When a washer or nut is identified as 1/2" (M8), this is the *Nominal size*, meaning the *inside diameter* is 1/2 inch (8mm metric thread diameter); if a second number is present it represents the *threads per inch* (distance between threads).

When bolt or capscrew is identified as 1/2 - 16 x 2" (M8 - 1.25 x 50), this means the *Nominal size*, or body diameter is 1/2 inch (8mm metric thread diameter), the second number, 16, represents the *threads per inch*, (1.25 thread diameter). The final number is the body length of the bolt or screw, 2 inches (50mm).

Torque Specification Chart						
FOR STANDARD MACHINE HARDWARE (Tolerance ± 20%)						
Hardware Grade	No Marks		SAE Grade 5		SAE Grade 8	
	SAE Grade 2		SAE Grade 5		SAE Grade 8	
Size Of Hardware	in/lbs		in/lbs		in/lbs	
	ft/lbs	Nm.	ft/lbs	Nm.	ft/lbs	Nm.
8-32	19	2.1	30	3.4	41	4.6
8-36	20	2.3	31	3.5	43	4.9
10-24	27	3.1	43	4.9	60	6.8
10-32	31	3.5	49	5.5	68	7.7
1/4-20	66	7.6	8	10.9	12	16.3
1/4-28	76	8.6	10	13.6	14	19.0
5/16-18	11	15.0	17	23.1	25	34.0
5/16-24	12	16.3	19	25.8	29	34.0
3/8-16	20	27.2	30	40.8	45	61.2
3/8-24	23	31.3	35	47.6	50	68.0
7/16-14	30	40.8	50	68.0	70	95.2
7/16-20	35	47.6	55	74.8	80	108.8
1/2-13	50	68.0	75	102.0	110	149.6
1/2-20	55	74.8	90	122.4	120	163.2
9/16-12	65	88.4	110	149.6	150	204.0
9/16-18	75	102.0	120	163.2	170	231.2
5/8-11	90	122.4	150	204.0	220	299.2
5/8-18	100	136	180	244.8	240	326.4
3/4-10	160	217.6	260	353.6	386	525.0
3/4-16	180	244.8	300	408.0	420	571.2
7/8-9	140	190.4	400	544.0	600	816.0
7/8-14	155	210.8	440	598.4	660	897.6
1-8	220	299.2	580	788.8	900	1,244.0
1-12	240	326.4	640	870.4	1,000	1,360.0

NOTES

- These torque values are to be used for all hardware excluding: locknuts, self-tapping screws, thread forming screws, sheet metal screws and socket head setscrews.
- Recommended seating torque values for locknuts:
 - for prevailing torque locknuts - use 65% of grade 5 torques.
 - for flange whizlock nuts and screws - use 135% of grade 5 torques.
- Unless otherwise noted on assembly drawings, all torque values must meet this specification.

Common Hardware Types

Hex Head Capscrew



Washer

Carriage Bolt



Lockwasher



Hex Nut

Wrench & Fastener Size Guide

1/4" Bolt or Nut Wrench—7/16"	5/16" Bolt or Nut Wrench—1/2"	3/8" Bolt or Nut Wrench—9/16"	7/16" Bolt or Nut Wrench (Bolt)—5/8" Wrench (Nut)—11/16"	1/2" Bolt or Nut Wrench—3/4"
M6 Bolt or Nut Wrench—10mm	M8 Bolt or Nut Wrench—13mm	M10 Bolt or Nut Wrench—17mm	M12 Bolt or Nut Wrench—19mm	M14 Bolt or Nut Wrench—22mm

Parts Manual for

SNAPPER®

YARD TRACTOR ELECTRIC CLUTCH HYDRO DRIVE RD RMO EUROPEAN 2010

Not for
Reproduction

IT IS THE POLICY OF BRIGGS & STRATTON CORP TO IMPROVE ITS PRODUCTS WHENEVER IT IS POSSIBLE AND PRACTICAL TO DO SO. WE RESERVE THE RIGHT TO MAKE CHANGES OR ADD IMPROVEMENTS AT ANY TIME WITHOUT INCURRING ANY OBLIGATION TO MAKE SUCH CHANGES ON PRODUCTS

Briggs & Stratton Yard Power Products Group

535 Macon Road
McDonough, GA, 30253 U.S.A.
800-935-2967

www.snapper.com

Copyright © 2010 Briggs & Stratton Corporation
Milwaukee, WI USA. All Rights Reserved

Manual No. 7104240
Revision: - 1/20/2010