

## Regent RD Series Lawn Tractors

### 18HP Product

Mfg. No.	Description
2690849	Regent RD, 18HP B&S Hydro and 40" Mower Deck (CE/Export)
2690853	Regent RD, 18HP B&S Hydro and 40" Mower Deck FR (CE/Export)

### 24HP Product

Mfg. No.	Description
2690850	Regent RD, 24HP B&S Hydro and 40" Mower Deck (CE/Export)
2690854	Regent RD, 24HP B&S Hydro and 40" Mower Deck FR (CE/Export)

Not for  
Reproduction

<b>PRODUCT COMPONENTS</b>	<b>PAGES</b>
Frame & Front Axle Group .....	4
Steering Group .....	6
Engine Group - 18HP & 24HP .....	8
Transmission SERVICE PARTS - Tuff Torq K46CW .....	10
Controls Group .....	14
Electrical Group - 18HP & 24HP .....	18
Hood, Grille & Dash Group .....	22
Seat Deck & Fuel Group .....	24
Mulching Flap Group .....	26
Rear Discharge Deflector Group .....	28
Lift Group - Manual .....	30
Wheels & Tires Group .....	32
Decals Group .....	34
Back Plate Group - 18HP & 24HP (After Serial Number 2013724990) .....	36
Collector Group .....	38
French Guard Group .....	40
40" Mower Deck - Belt & Idler Arm Group .....	42
40" Mower Deck - Housing, Hitch, Arbors & Blades Group .....	46
<b>Torque Specification Chart .....</b>	<b>Inside Back Cover</b>

Not for  
Reproduction

## Frame & Front Axle Group

NOTE: Unless noted otherwise,  
use the standard hardware torque  
specification chart.

2988017

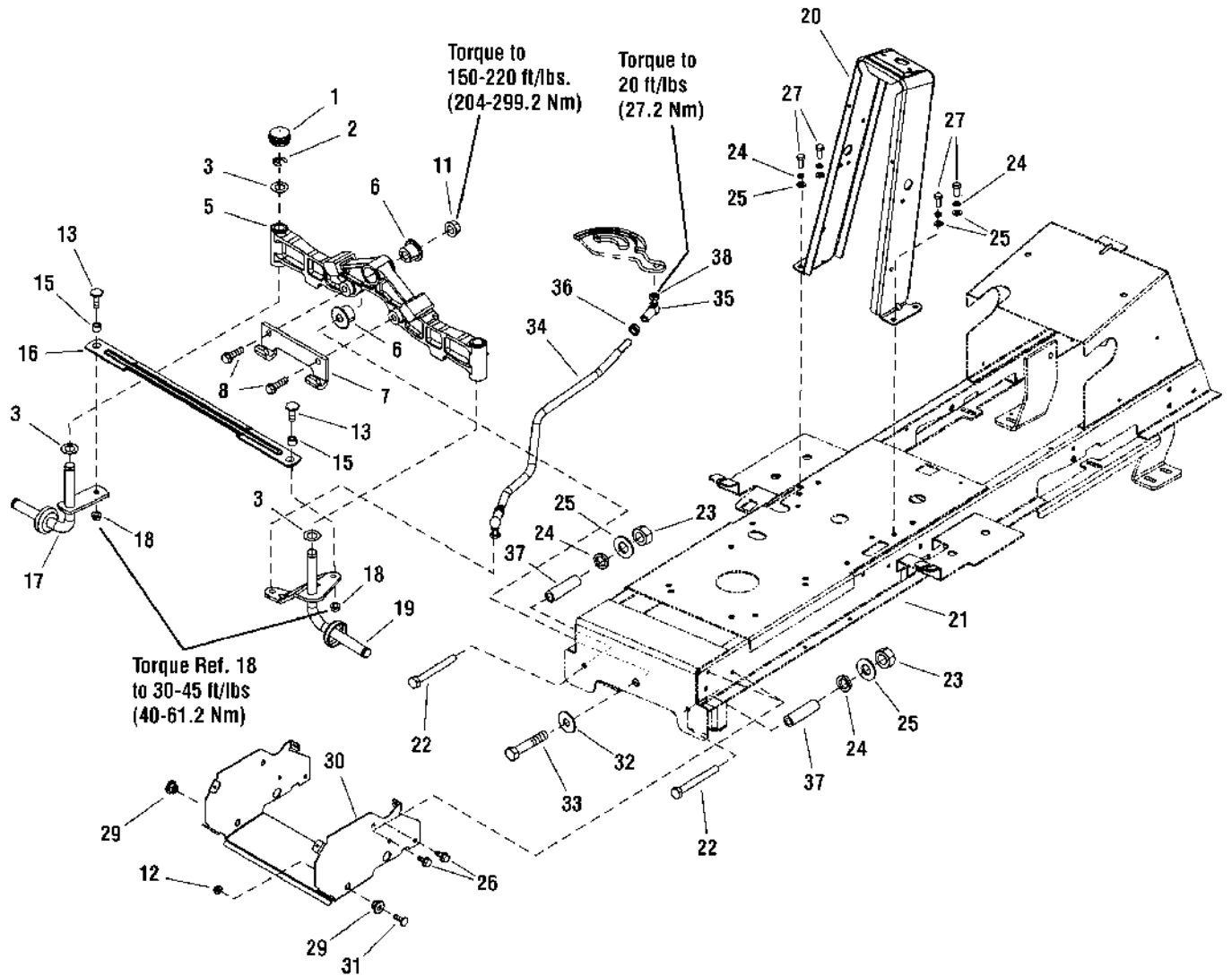

The above parts group applies to the following Mfg. Nos.:

- 2690849 - Regent RD
- 2690850 - Regent RD
- 2690853 - Regent RD
- 2690854 - Regent RD

## Frame & Front Axle Group

REF NO	PART NO.	QTY.	DESCRIPTION
1	1726504SM	2	CAP, Hub
2	1611710SM	2	CLIP RING, 3/4
3	2860183SM	4	WASHER, 3/4
5	1728018SM	1	AXLE, Front Iron Casting Machined (Includes Ref. Nos. 1, 2, 3, 17 & 19)
6	1730186SM	2	BUSHING, Axle Pivot
7	1721918ASM	1	HOOK, "J"
8	1960652SM	2	CAPSCREW, 7/16-14 x 1-1/2
11	2860646SM	1	NUT, Hex Flange Two-Way Lock, 5/8-11
12	1931277SM	2	NUT, Hex Whiz Lock, 5/16-18
13	1960032SM	2	CAPSCREW, Hex Head, 3/8-16 x 1-1/4, G5
15	1731912SM	2	BUSHING, Powdered Metal
16	1728080ASM	1	ROD, Tie
17	1727872ASM	1	SPINDLE & CUP ASSEMBLY, RH
18	1930645SM	2	LOCKNUT, Hex, 3/8-16
19	1727873ASM	1	SPINDLE & ARM ASSEMBLY, LH
20	1727260SM	1	TOWER
21	1736499YP	1	FRAME
22	1735874YP	2	BOLT, M8 x 75
23	1735934YP	2	NUT, M8
24	1735989YP	6	WASHER, 8.4
25	1736000YP	6	WASHER, 8
26	1930601SM	4	CAPSCREW, Hex Head, Taptite, 5/16-18 x 5/8
27	1735868YP	4	BOLT, M8 x 20
29	1728086SM	2	PIVOT, Hood
30	1735973YP	1	SUPPORT, Muffler
31	1931335SM	2	BOLT, Carriage, 5/16-18 x 1
32	1960035SM	1	WASHER, 5/8
33	2860744SM	1	CAPSCREW, Hex Head, 5/8-11 x 3-1/4, G5
34	1735919YP	1	LINK, Drag
35	1735851YP	2	BALLJOINT, CS16 M10-M12
36	1735928YP	2	NUT, M12
37	1735892YP	2	SPACER, Front Axle 0-9521-291
38	1735926YP	2	NUT, M10

## Footnotes

---

### The above parts group applies to the following Mfg. Nos.:

2690849 - Regent RD  
2690850 - Regent RD  
2690853 - Regent RD  
2690854 - Regent RD

## Steering Group

NOTE: Unless noted otherwise,  
use the standard hardware torque  
specification chart.

2988023

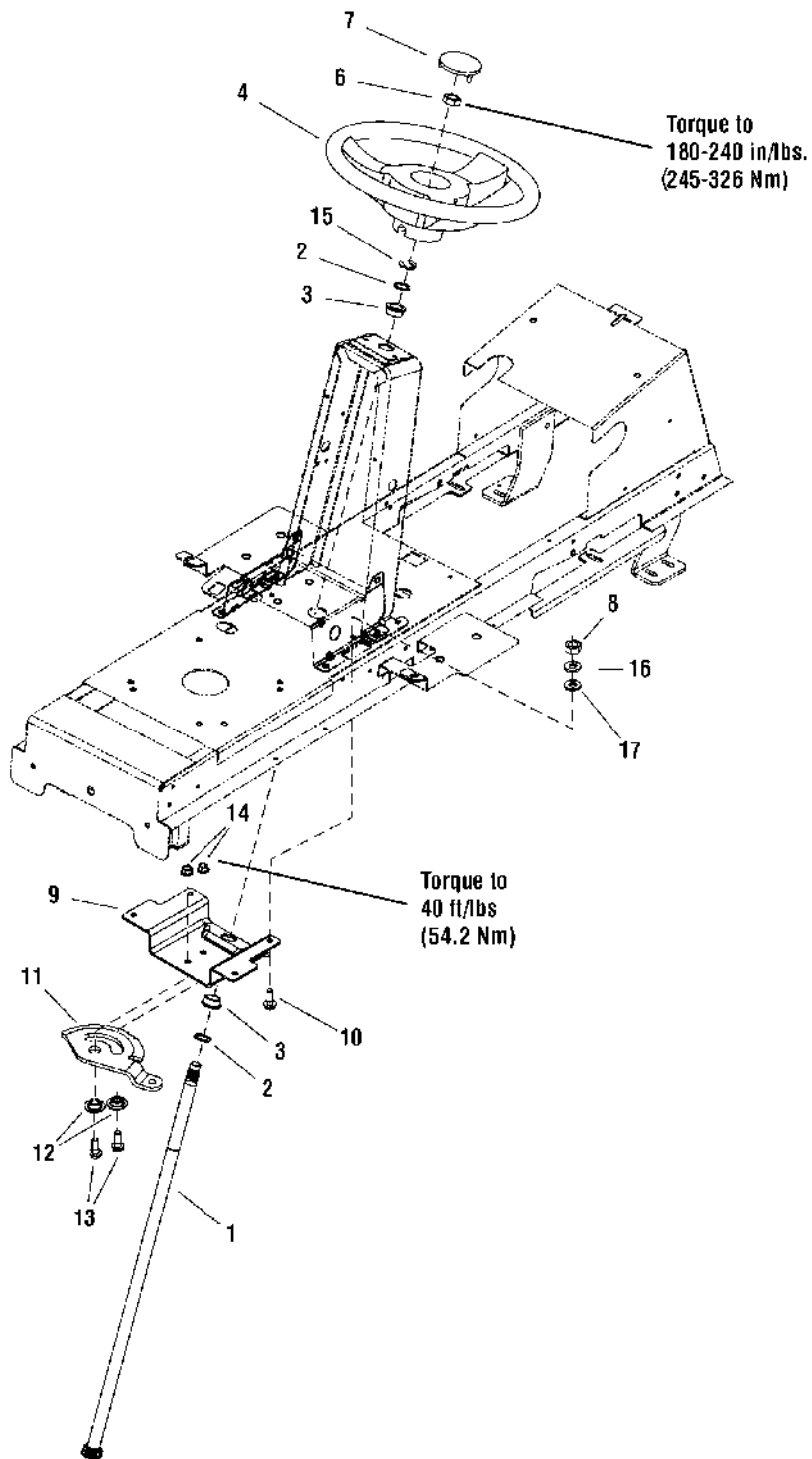

The above parts group applies to the following Mfg. Nos.:

- 2690849 - Regent RD
- 2690850 - Regent RD
- 2690853 - Regent RD
- 2690854 - Regent RD

## Steering Group

REF NO	PART NO.	QTY.	DESCRIPTION
1	1727813SM	1	SHAFT, Steering Gear & Spline Yellow
2	1960114SM	2	WASHER, 3/4
3	1729665SM	2	BUSHING, Steering
4	1728069SM	1	STEERING WHEEL, w/Aluminum Insert
6	1960576SM	1	NUT, Hex Lock, ESNA Light, 5/8-18, Thin
7	1722319SM	1	CAP, Steering Wheel, Simplicity (Decal Not Included)
8	1735934YP	4	NUT, M8
9	1727940SM	1	BRACKET, Sector Support
10	1735870YP	4	BOLT, M8 x 25
11	1728027SM	1	GEAR, Steering, 26 teeth
12	1728122SM	2	SPACER, Sector Gear 0.374ID
13	1934654SM	2	CAPSCREW, Hex Flange Hd, Whizlock, 3/8-16 x 1
14	1931211SM	2	NUT, Hex Flange Whiz Lock, 3/8-16
15	1611710SM	1	RING, Clipping Extension
16	1735989YP	4	WASHER, 8.4
17	1736000YP	4	WASHER, 8

Not for  
Reproduction

## Footnotes

---

### The above parts group applies to the following Mfg. Nos.:

2690849 - Regent RD  
2690850 - Regent RD  
2690853 - Regent RD  
2690854 - Regent RD

## Engine Group - 18HP & 24HP

2988771

NOTE: Unless noted otherwise,  
use the standard hardware torque  
specification chart.

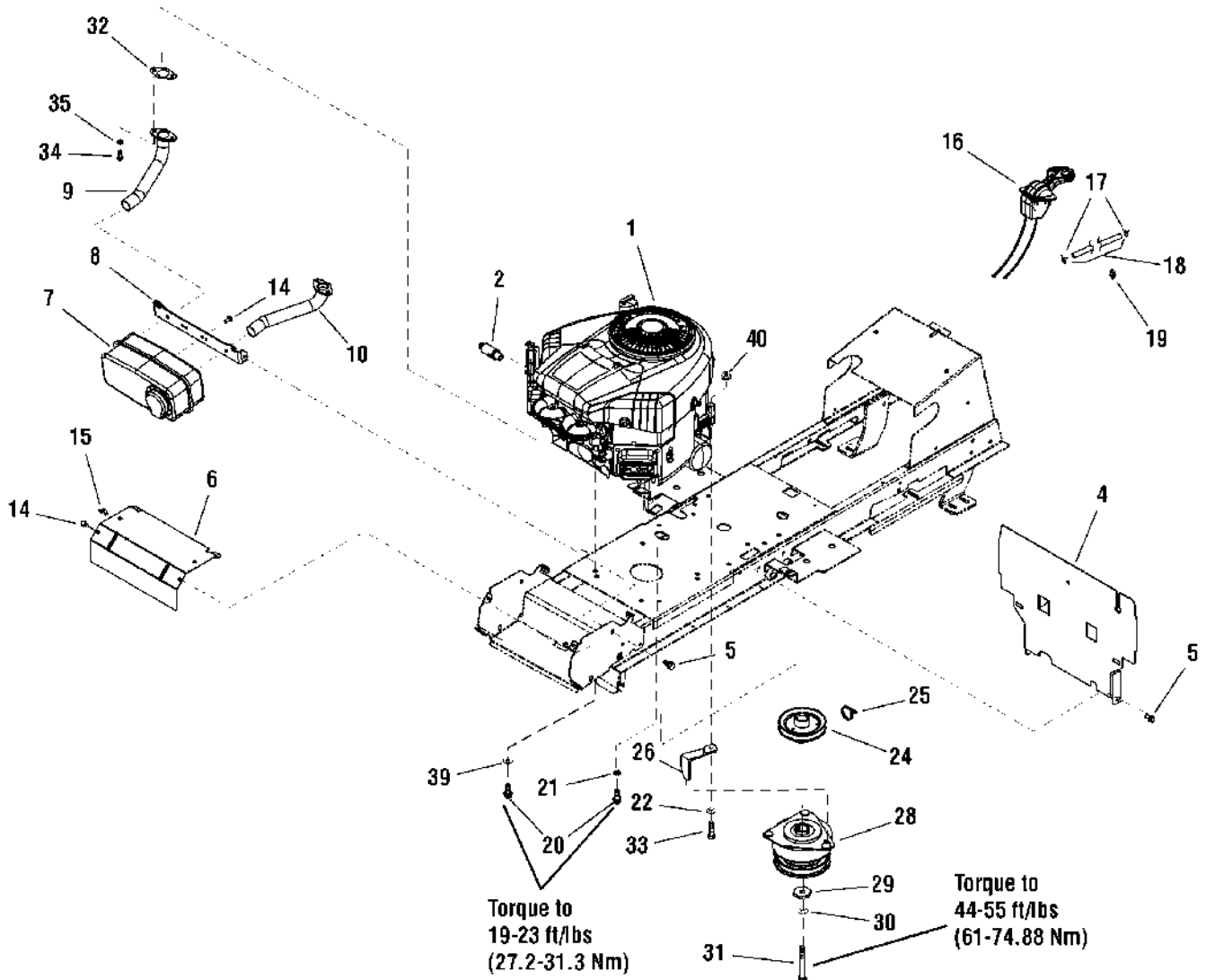

The above parts group applies to the following Mfg. Nos.:

- 2690849 - Regent RD
- 2690850 - Regent RD
- 2690853 - Regent RD
- 2690854 - Regent RD



## Engine Group - 18HP & 24HP

REF NO	PART NO.	QTY.	DESCRIPTION
1	405577-0130-B1	1	*ENGINE, 18HP Briggs & Stratton Twin (Engine Model: 405577-0130-B1)
1	445677-0129-B1	1	*ENGINE, 24HP Briggs & Stratton V-Twin (Engine Model: 445677-0129-B1)
2	1717473SM	1	VALVE, Shut Off Oil Drain
4	1735962YP	1	SHIELD, Heat
5	1930601SM	4	CAPSCREW, Hex Head, Taptite, 5/16-18 x 5/8
6	1727997SM	1	SHIELD, Heat
7	1727994SM	1	MUFFLER, B&S Twin
8	1727976SM	1	SUPPORT, Muffler
9	1727979SM	1	PIPE, Exhaust R.H.
10	1727980SM	1	PIPE, Exhaust L.H.
14	1925003SM	4	CAPSCREW, Hex Head, Taptite, 1/4-20 x 1/2
15	2834683SM	1	CLIP, Wire
16	1734505SM	1	CONTROL, Throttle Twin
17	1736993YP	2	CLAMP, Hose
18	1735913YP	1	HOSE, Fuel 1-9920-247
19	1730268SM	2	CLIP, Hose
20	1736994YP	3	SCREW, M8 x 35
21	2820427SM	1	LOCKWASHER, External Tooth, 3/8
22	1736995YP	1	WASHER, 9
24	1732576SM	1	PULLEY & HUB ASSEMBLY, Engine
25	1735980YP	1	TIE
26	1732875SM	1	RETAINER, Clutch
28	1736105YP	1	CLUTCH, Electric (MID OGURA)
29	1708264SM	1	WASHER, Hex, 7/16
30	1918199SM	1	LOCKWASHER, 7/16
31	1960649SM	1	CAPSCREW, Hex Head, 7/16-20 x 3-1/2 G5
32	1731214SM	1	GASKET, Exhaust
33	1736996YP	2	SCREW, M8 x 45
34	1936228SM	2	CAPSCREW, Hex Socket Head, 5/16-18 x 3/4 G8
35	1917356SM	2	LOCKWASHER, 5/16
39	1736999YP	4	WASHER, 8.4
40	1737000YP	4	NUT, 8

### Footnotes

NOTE\* See your local Briggs & Stratton distributor for parts and service.

---

### The above parts group applies to the following Mfg. Nos.:

2690849 - Regent RD  
2690850 - Regent RD  
2690853 - Regent RD  
2690854 - Regent RD

# Transmission SERVICE PARTS - Tuff Torq K46CW

NOTE: Unless noted otherwise,  
use the standard hardware torque  
specification chart.

1735476

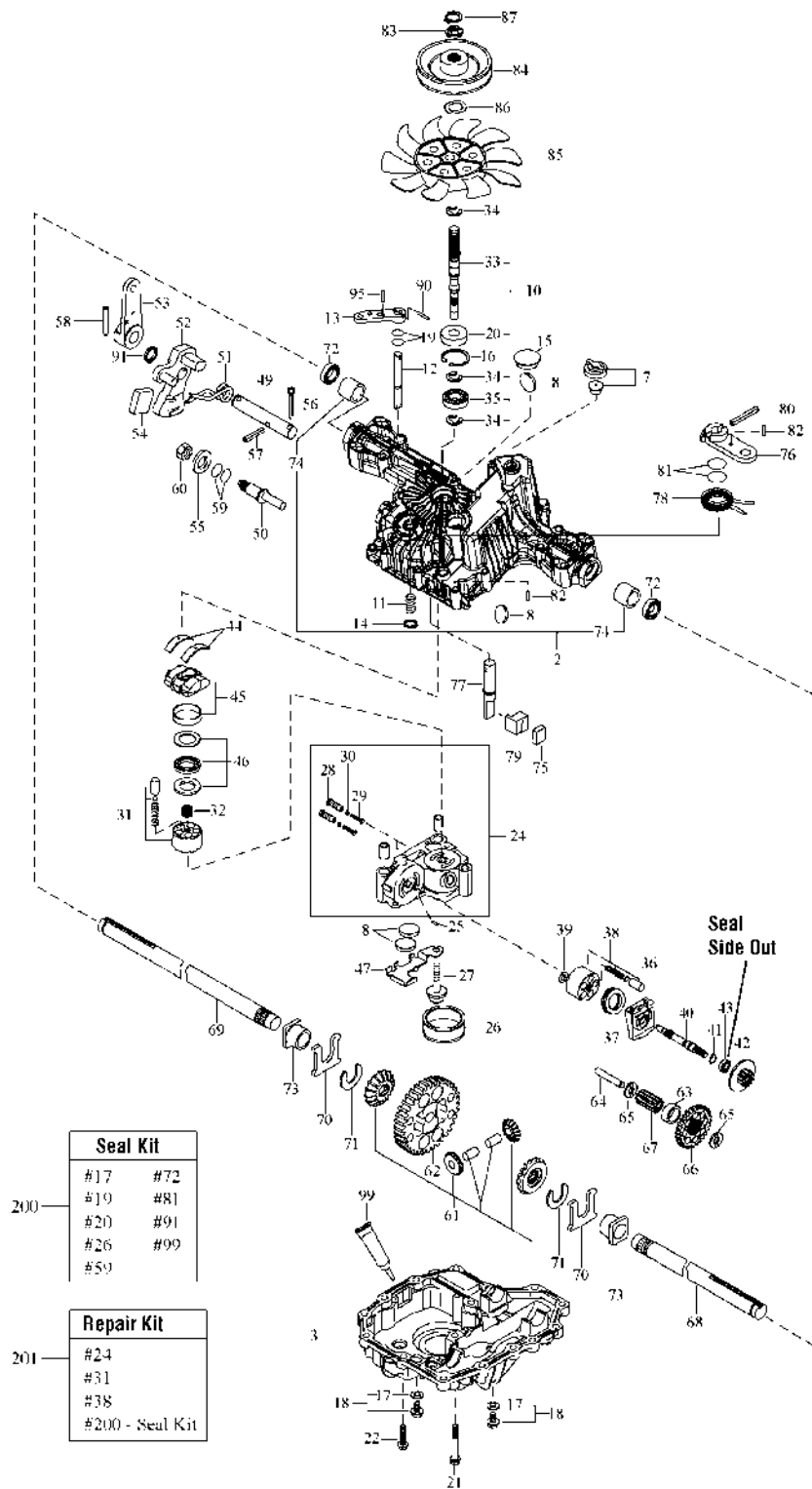

The above parts group applies to the following Mfg. Nos.:

- 2690849 - Regent RD
- 2690850 - Regent RD
- 2690853 - Regent RD
- 2690854 - Regent RD

## Transmission SERVICE PARTS - Tuff Torq K46CW

REF NO	PART NO.	QTY.	DESCRIPTION
--	1735476YP		TRANSMISSION, Tuff Torq, K46CW
2	-----		*KIT, Upper Case
3	1724278SM		LOWER CASE
7	1739891YP		VENT VALVE
8	1724279SM		MAGNET
10	-----		*KIT, Pump Shaft / Bearing
11	-----		*SPRING 25
12	-----		*BYPASS SHAFT
13	1720418SM		LEVER, Bypass
14	-----		*RING, Snap, 10
15	1724282SM		SEALING CAP 30
16	1708650SM		SNAP RING C 35
17	1724323YP		SEAL WASHER 8
18	-----		*KIT, Drain Bolt
19	1708691SM		O-RING 1A P10A
20	1708651SM		SEAL TC 153507
21	-----		*SCREW, Tapping, 8 * 55
22	1707789SM		SCREW, Tapping, 8 * 30
24	-----		*KIT, Center Case
25	1718070SM		PIN 3 * 9.8
26	-----		*FILTER 105
27	-----		*BOLT 10 * 75
28	-----		*IDS VALVE 1.2
29	-----		*IDS SPRING
30	-----		*IDS FILTER 300
31	1725831SM		KIT, Cylinder Block (Pump)
32	1724290SM		SPRING
33	1739892YP		PUMP SHAFT
34	1718076SM		E-RING 15
35	1708673SM		BEARING 6202C3
36	1718077SM		MOTOR HOUSING
37	-----		*THRUST BEARING 51106
38	-----		*KIT, Cylinder Block (Motor)
39	1718074SM		WASHER 12 * 24 * 1
40	1724943SM		MOTOR SHAFT
41	1708672SM		SNAP RING S15
42	1724944SM		BRAKE DISC/MOTOR GEAR (10T)
43	1718083SM		BEARING 6202
44	1718089SM		THRUST METAL
45	-----		*SWASH PLATE CMP
46	-----		*THRUST BEARING (PUMP) KIT
47	-----		*MAGNET HOLDER
49	-----		*CONTROL SHAFT
50	1721184SM		FULCRUM

### Footnotes

\*Note: See your local authorized dealership for parts and warranty or contact Tuff Torq at [www.tufftorqservices.com](http://www.tufftorqservices.com) (U.S. 1-866-572-3441 Int'l 01-423-585-1977)

### The above parts group applies to the following Mfg. Nos.:

2690849 - Regent RD  
 2690850 - Regent RD  
 2690853 - Regent RD  
 2690854 - Regent RD

# Transmission SERVICE PARTS - Tuff Torq K46CW

NOTE: Unless noted otherwise,  
use the standard hardware torque  
specification chart.

1735476

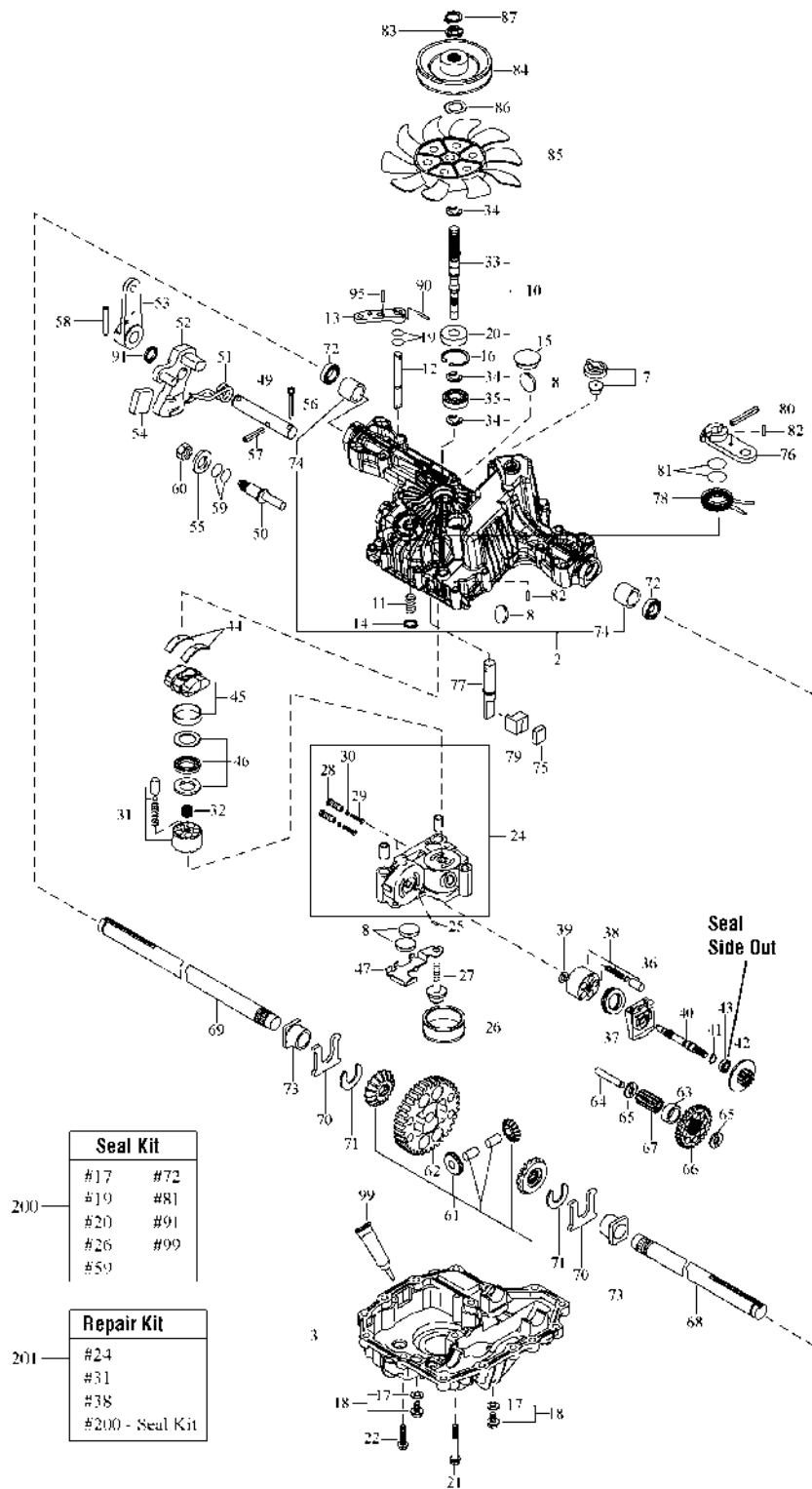

The above parts group applies to the following Mfg. Nos.:

- 2690849 - Regent RD
- 2690850 - Regent RD
- 2690853 - Regent RD
- 2690854 - Regent RD

## Transmission SERVICE PARTS - Tuff Torq K46CW

REF NO	PART NO.	QTY.	DESCRIPTION
51	----		*TORSION SPRING
52	----		*CONTROL ARM A
53	1724347SM		CONTORL LEVER C
54	----		*JERKY PLATE
55	----		*WASHER 12
56	----		*COTTER PIN 1/8 * 3/4
57	----		*SPRING PIN 6 * 36
58	1960588SM		ROLL PIN 6 * 40
59	1707879SM		O-RING 1A P14
60	----		*NUT 12
61	----		*KIT, Differential Gear
62	----		*FINAL GEAR (54T)
63	----		*FINAL PINION COLLAR
64	----		*REDUCTION SHAFT
65	1724948SM		WASHER 12 * 32 * 32
66	1724949SM		REDUCTION GEAR (38T)
67	----		*FINAL PINION GEAR (10T)
68	1724303SM		AXLE SHAFT, LEFT
69	1724304SM		AXLE SHAFT, RIGHT
70	1718112SM		THRUST WASHER
71	1718113SM		RING 17
72	1718111SM		SEAL 19 * 32 * 8
73	1718110SM		BUSHING 19 * 25
74	----		*BUSHING 19.05
75	1724305SM		BRAKE SHOE
76	1724306SM		BRAKE LEVER
77	----		*BRAKE SHAFT
78	----		*BRAKE RETURN SPRING
79	1724309SM		BRAKE ACTUATOR
80	1724310SM		SPRING PIN 5 * 32
81	1708690SM		O-RING 1A P12
82	----		*SPRING PIN 4 * 16
83	1724312SM		SPLINE COLLAR
84	1739893YP		PULLEY C
85	1724314SM		FAN, White
86	1724315SM		WASHER, Wave
87	1724316SM		RING, Snap
90	1707839SM		SPRING PIN 3.0A * 20
91	1724318SM		OIL SEAL 16 * 22 * .03
95	----		*SPRING PIN 3.0A * 16
99	----		*SEALANT
200	1739894YP		SEAL KIT (K46 & T40)
201	----		*KIT, Repair, K46 (CE,CR)

### Footnotes

\*Note: See your local authorized dealership for parts and warranty or contact Tuff Torq at [www.tufftorqservices.com](http://www.tufftorqservices.com) (U.S. 1-866-572-3441 Int'l 01-423-585-1977)

### The above parts group applies to the following Mfg. Nos.:

2690849 - Regent RD  
 2690850 - Regent RD  
 2690853 - Regent RD  
 2690854 - Regent RD

## Controls Group

NOTE: Unless noted otherwise,  
use the standard hardware torque  
specification chart.

2988009

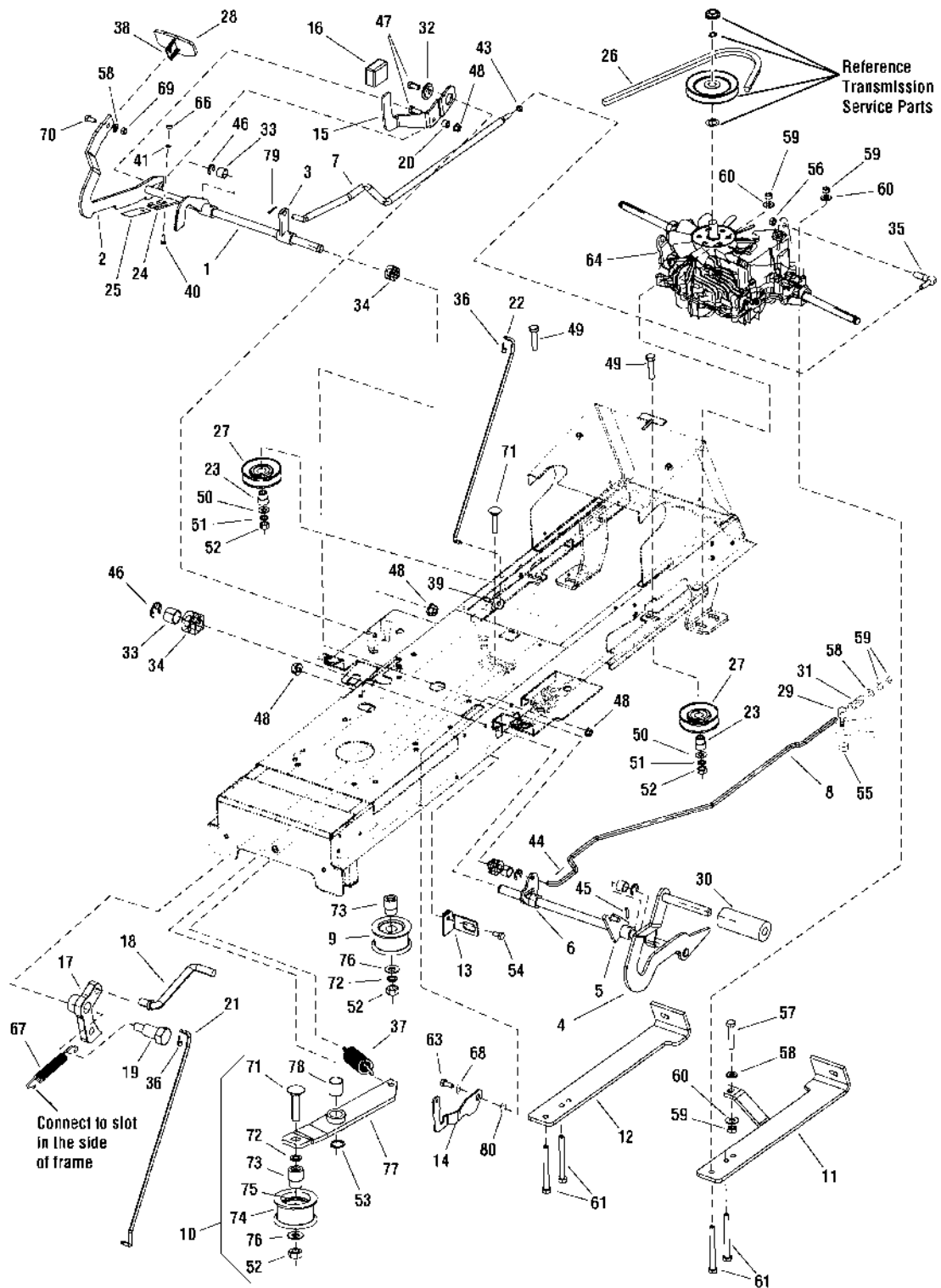

The above parts group applies to the following Mfg. Nos.:

- 2690849 - Regent RD
- 2690850 - Regent RD
- 2690853 - Regent RD
- 2690854 - Regent RD

## Controls Group

REF NO	PART NO.	QTY.	DESCRIPTION
1	1735940YP	1	PEDAL, Forward
2	1735952YP	1	RATCHET
3	1735847YP	1	ARM
4	1735941YP	1	PEDAL, Brake
5	1735918YP	1	LEVER, Parking Brake
6	1735917YP	1	LEVER, Brake
7	1735959YP	1	ROD, Traveling
8	1735957YP	1	ROD, Brake
9	1735951YP	1	PULLEY, Tensioning
10	1735950YP	1	PULLEY, Idler (Includes References: 52, 71, 72, 73, 74, 75, 76, 77, & 78)
11	1735910YP	1	HOLDER, Left
12	1735911YP	1	HOLDER, Right
13	1735974YP	1	SUPPORT, Switch
14	1735595ASM	1	LATCH, Brake Lock
15	1727246SM	1	PEDAL, Reverse
16	1727259SM	1	PAD, Foot Pedal
17	1727897SM	1	LATCH, Cruise
18	1727899SM	1	ROD, Cruise .312DIA 2.83 LG
19	1728976SM	1	BOLT, Shoulder 5/16-18 x 1-5/8
20	1728024SM	1	SPACER, Foot Pedal
21	1727898SM	1	ROD, Cruise, LATCH, Upper
22	1727267SM	1	ROD, .250dia 15.95 LG
23	1735880YP	2	BUSHING, 0-9421-418
24	1736001YP	1	WASHER, Lock
25	1735972YP	1	SPRING, Flat 0-9740-221
26	1735987YP	1	V-BELT, Li, BBT, 13 x 2580
27	1735949YP	2	PULLEY, Compensa C-00237/1
28	1735942YP	1	PEDAL, Forward Rubber
29	1735853YP	1	BOLT, 0-9016-447
30	1727261SM	1	PEDAL, Brake Pad
31	1735968YP	1	SPRING, TLZ 250.150.0530 Yellow
32	1727935SM	1	SPACER, Pivot
33	1735896YP	4	SPACER, Pedal 0-9521-288
34	1735881YP	4	BUSHING, 0-9462-202
35	1735850YP	1	BALL JOINT, CS 13 DIN 71802 M8 Silver
36	1728111SM	2	LINKAGE CLIP, .250 dia
37	1735969YP	1	SPRING, TZ 2x14 x 62 Yellow
38	1735943YP	1	PEDAL, Forward Top
39	1735875YP	1	BOLT, Eye M6 x 80 BN1006
40	1735866YP	1	BOLT, M6 x 16
41	1735998YP	2	WASHER, 6.4
43	1735936YP	1	NUT, M8
44	1735963YP	1	SPINDLE, 2 x 20
45	1735946YP	4	PIN, Flex 5 x 25

### Footnotes

\*Note: See your local authorized dealership for parts and warranty or contact Tuff Torq at [www.tufftorqservices.com](http://www.tufftorqservices.com) (U.S. 1-866-572-3441 Int'l 01-423-585-1977)

### The above parts group applies to the following Mfg. Nos.:

2690849 - Regent RD  
 2690850 - Regent RD  
 2690853 - Regent RD  
 2690854 - Regent RD

## Controls Group

NOTE: Unless noted otherwise,  
use the standard hardware torque  
specification chart.

2988009

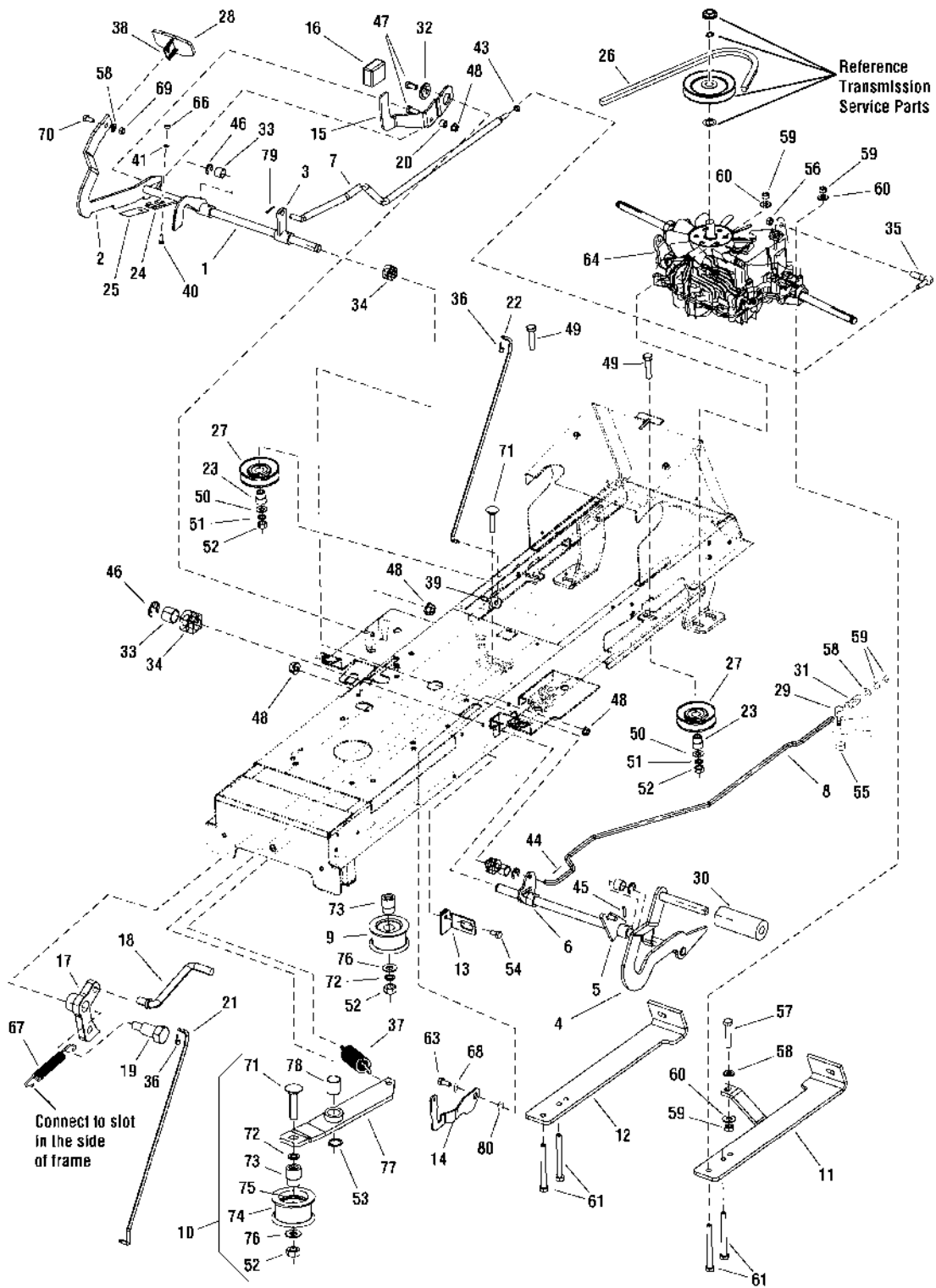

The above parts group applies to the following Mfg. Nos.:

- 2690849 - Regent RD
- 2690850 - Regent RD
- 2690853 - Regent RD
- 2690854 - Regent RD



## Controls Group

REF NO	PART NO.	QTY.	DESCRIPTION
46	1735920YP	4	LOCK RING, 12
47	1960223SM	2	BOLT, Carriage, 5/16-18 x 1-1/4
48	1931277SM	4	NUT, Hex Flange, 5/16-18 x 1-5/8
49	1735855YP	2	BOLT, M10 x 40
50	1735990YP	2	WASHER, 10.5
51	1735991YP	2	WASHER, 10.0
52	1735925YP	4	NUT, M10
53	1735921YP	1	LOCK RING, 16
54	1930601SM	1	SCREW, Tap 5/16-18 x 5/8
55	1735924YP	1	NUT, M10
56	1735938YP	1	NUT, M8 DIN 6923 8 Yellow, Tooth
57	1735873YP	1	BOLT, M8 x 45
58	1735989YP	7	WASHER, 8.4
59	1735934YP	7	NUT, M8
60	1736000YP	5	WASHER, 8
61	1735874YP	4	BOLT, M8 x 75
63	1729576SM	1	BOLT, Shoulder 5/16-18 x 1.15
64	1729589SM	1	* TRANSMISSION, Tuff Torq K46BL (Transmission Model: K46-BL) (Early Models)
64	1735476YP	1	* TRANSMISSION, Tuff Torq, K-46CW (Transmission Model: K46-CW) (Late Models)
66	1735933YP	3	NUT, M6
67	2159181SM	1	SPRING
68	1735994YP	3	WASHER, 14 x 26/0.2
69	1735935YP	1	NUT, M8
70	1735854YP	1	BOLT, M8 x 16
71	1736455YP	2	SCREW, M10 x 45
72	1736456YP	2	LOCK RING, 40
73	1736457YP	2	BUSING, Pulley, Tension
74	1736458YP	1	PULLEY
75	1736459YP	1	BALL BEARING, Pulley, 62032RS
76	1736460YP	2	WASHER, 11, Zinc
77	1736461YP	1	ARM, Tension Pulley
78	1736462YP	1	BEARING, Slide
79	1735964YP	1	SPINDLE, 3.2 x 25
80	1739135YP	1	WASHER, 16 x 22 x 1

### Footnotes

\*Note: See your local authorized dealership for parts and warranty or contact Tuff Torq at [www.tufftorqservices.com](http://www.tufftorqservices.com) (U.S. 1-866-572-3441 Int'l 01-423-585-1977)

### The above parts group applies to the following Mfg. Nos.:

2690849 - Regent RD  
 2690850 - Regent RD  
 2690853 - Regent RD  
 2690854 - Regent RD

# Electrical Group - 18HP & 24HP

NOTE: Unless noted otherwise,  
use the standard hardware torque  
specification chart.

2988014

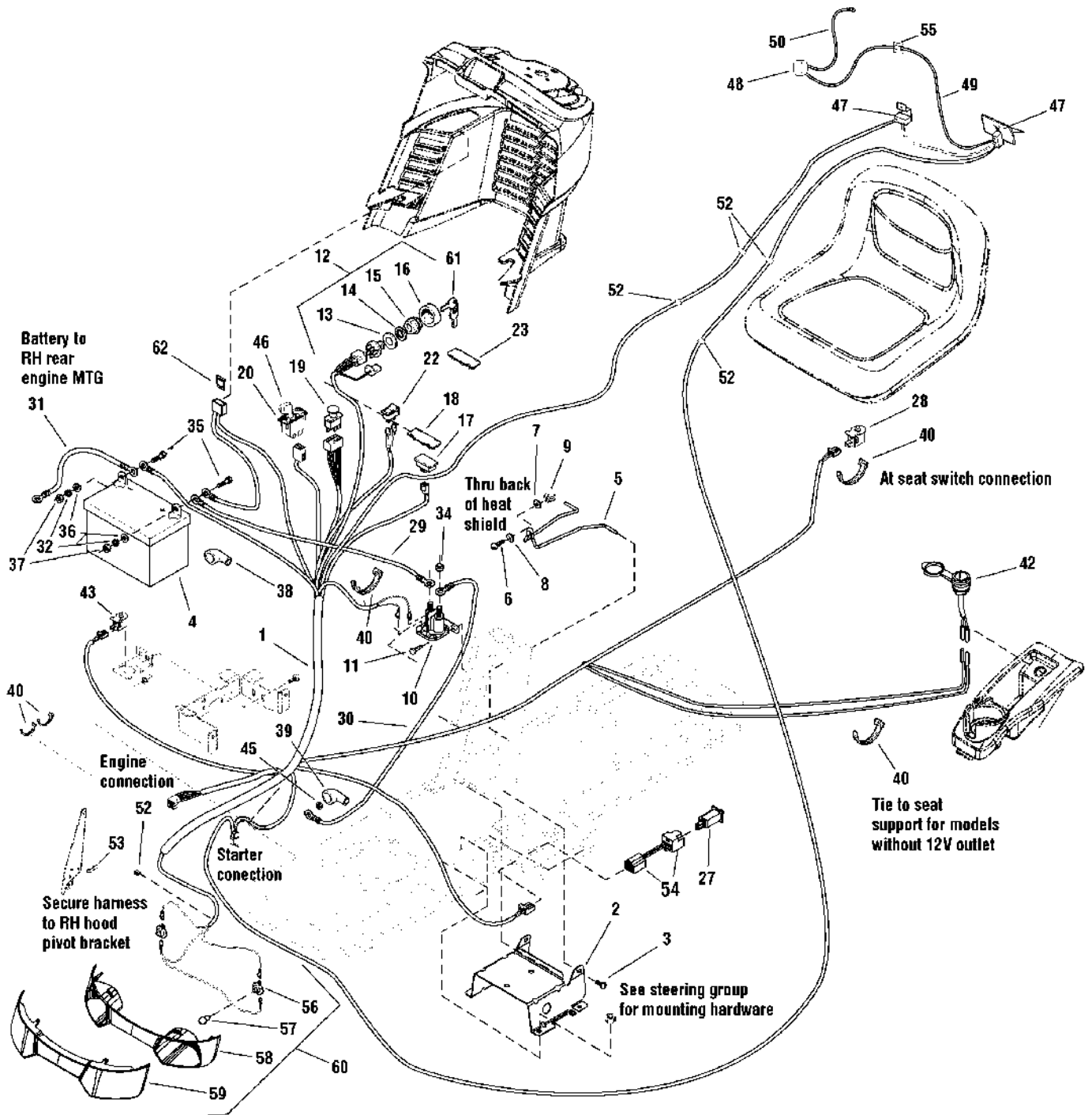

The above parts group applies to the following Mfg. Nos.:

- 2690849 - Regent RD
- 2690850 - Regent RD
- 2690853 - Regent RD
- 2690854 - Regent RD

## Electrical Group - 18HP & 24HP

REF NO	PART NO.	QTY.	DESCRIPTION
1	1736864YP	1	HARNESSES, Main
2	1727282SM	1	SUPPORT, Battery
3	1930601SM	4	SCREW, Hex Washer Head Taptite 5/16-18 x 5/8
4	1685215SM	1	BATTERY, 12 Volt, 230 CCA, L Terminal
5	1730007SM	1	HOLD DOWN, Battery
6	1931318SM	1	BOLT, Carriage, 1/4-20 x 7/8
7	1960353SM	1	WASHER, Plain, 1/4
8	1960518SM	1	NUT, Push .25
9	1920397SM	1	NUT, 1/4 ESNA
10	1728963SM	1	SOLENOID, 12V
11	1925003SM	2	CAPSCREW, Taptite, 1/4-20 x 1/2
12	1686734SM	1	SWITCH ASSEMBLY, Ignition (Includes References 13, 14, 15, 16 & 61)
13	2101025SM	1	WASHER, 5/8 x 1
14	1960547SM	1	LOCKWASHER, Internal Tooth, 5/8
15	1717549SM	1	NUT, Hex Flange, 5/8-32, Ignition Switch
16	1717550SM	1	COVER, Ignition Switch
17	1728068SM	1	HOUR METER (24HP)
18	1729993SM	1	PLUG, Hour Meter (18HP)
19	1722887SM	1	SWITCH, PTO
20	1726556SM	1	SWITCH, RMO Module Only
22	1716951SM	1	SWITCH, Headlights, 2 Terminal
23	1722611SM	1	PLUG, Hole, Square
27	1732006SM	1	SWITCH, Push (Foot Pedal)
28	1732005SM	1	SWITCH, Push NC (Seat)
29	1716549SM	1	CABLE, # 6 x 10" Long, 2 Ring Terminals
30	1721830SM	1	CABLE, #6 x 25" Long, Ring Terminals
31	1713163SM	1	CABLE, #6 20.0 Lg Black
32	2816964SM	2	LOCKWASHER, 1/4
34	2860750SM	2	NUT, KEPS Lock 5/16-24
35	2823341SM	2	CAPSCREW, Hex Head, 1/4-20 x 3/4
36	2821319SM	2	WASHER, 1/4 I.D.
37	2816622SM	2	NUT, Hex, 1/4-20
38	1677296SM	1	BOOT, Insulator Battery Terminal
39	1713535SM	1	BOOT, Insulator Cable Terminal, 1-15/16 Long, Red
40	1735980YP	5	TIE
42	7073090SM	1	OUTLET, 12 Volt DC Power
43	1732004SM	1	SWITCH, Seat
45	1960294SM	1	NUT, Hex, Whizlock, 1/4-20
46	1726557SM	1	KEY, RMO Module, Plastic
47	1735922YP	2	MICROSWITCH, MKH 12 D13 S1
48	1735852YP	1	BEEPER
49	1736003YP	1	WIRE, 9-8316-616
50	1736002YP	1	WIRE, 9-8316-615

### Footnotes

---

#### The above parts group applies to the following Mfg. Nos.:

2690849 - Regent RD  
2690850 - Regent RD  
2690853 - Regent RD  
2690854 - Regent RD

# Electrical Group - 18HP & 24HP

NOTE: Unless noted otherwise,  
use the standard hardware torque  
specification chart.

2988014

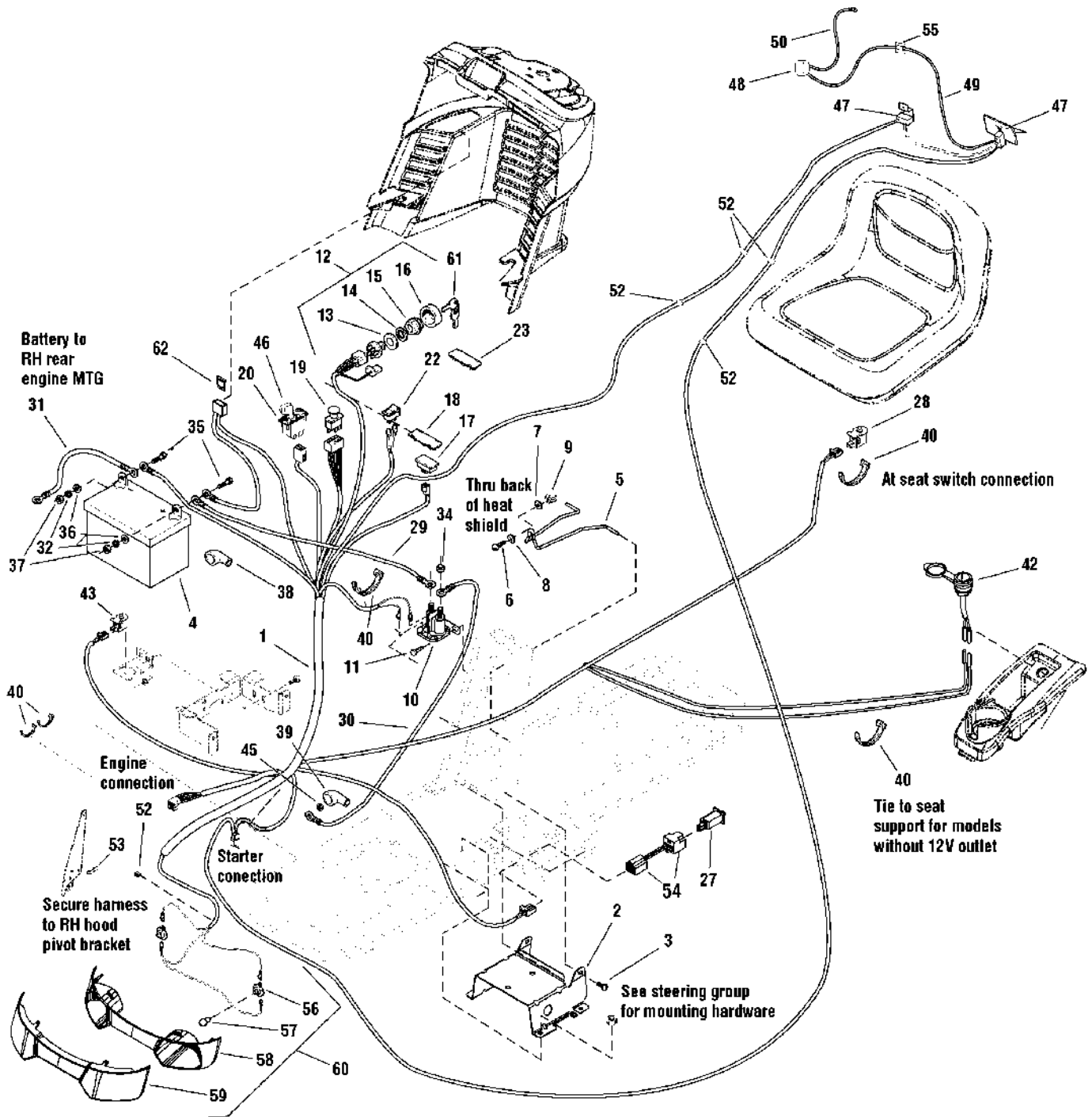

The above parts group applies to the following Mfg. Nos.:

- 2690849 - Regent RD
- 2690850 - Regent RD
- 2690853 - Regent RD
- 2690854 - Regent RD

## Electrical Group - 18HP & 24HP

REF NO	PART NO.	QTY.	DESCRIPTION
52	1735882YP	7	CABLE, Clip, WSBH 1-0-1
53	2834683SM	1	CLIP, Wire 1/8
54	1734025SM	1	WIRING ASSEMBLY, All Conditions Shutdown
55	1735884YP	1	CLIP, Cable, WCK 460 01/A
56	1723451SM	2	SOCKET, Headlight
57	1677371SM	2	BULB, Headlight, 12.8V
58	1728973SM	1	REFLECTOR, Headlight
59	1728974SM	1	LENS, Headlight
60	1727296SM	1	HEADLIGHT ASSEMBLY (Includes References 56, 57, 58 & 59)
61	1717163SM	1	IGNITION KEY (Set of 2)
62	1731957SM	1	FUSE, Wiring Harness

Not for  
Reproduction

### Footnotes

---

**The above parts group applies to the following Mfg. Nos.:**

2690849 - Regent RD  
2690850 - Regent RD  
2690853 - Regent RD  
2690854 - Regent RD

## Hood, Grille & Dash Group

2988883

NOTE: Unless noted otherwise,  
use the standard hardware torque  
specification chart.

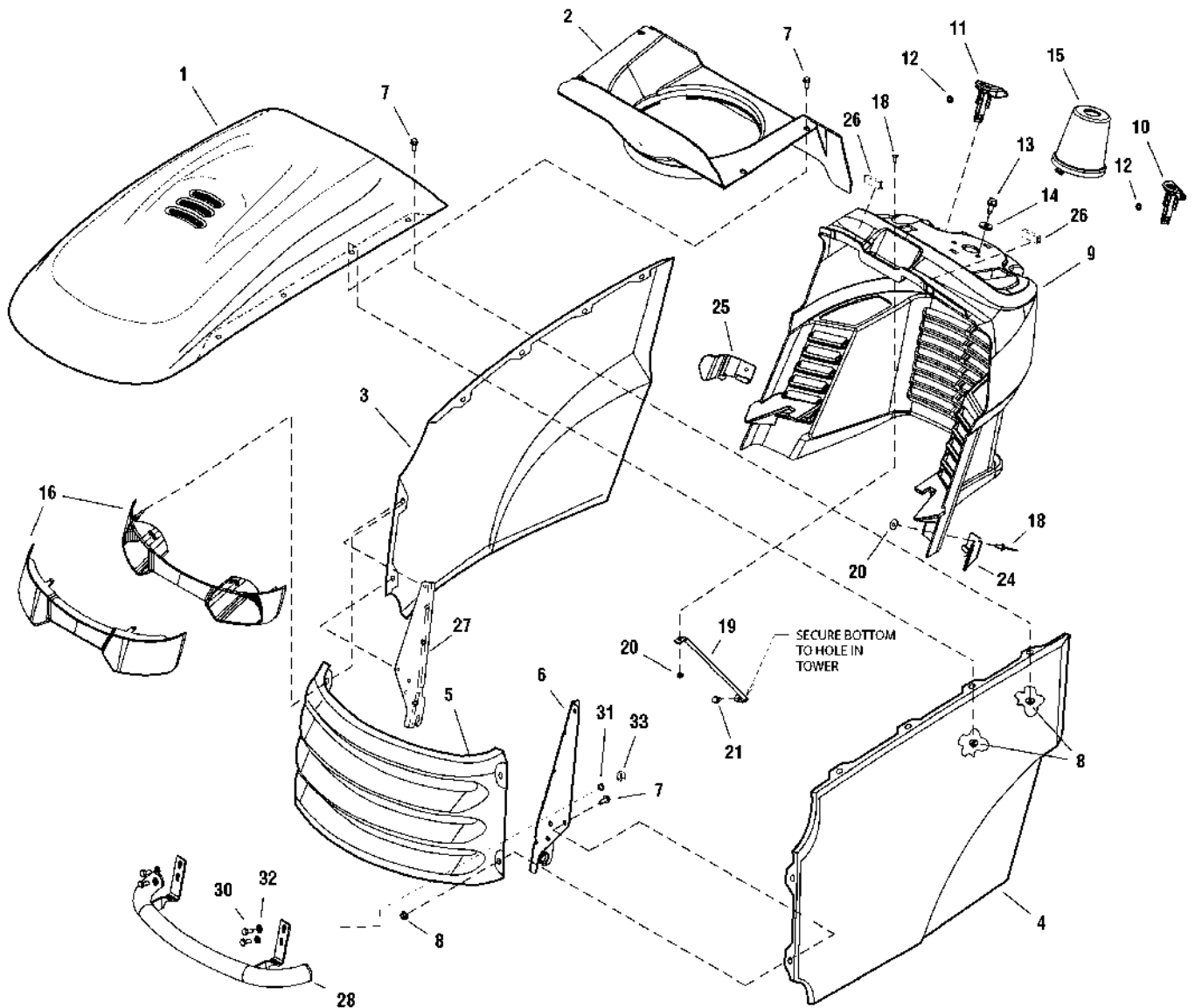

The above parts group applies to the following Mfg. Nos.:

- 2690849 - Regent RD
- 2690850 - Regent RD
- 2690853 - Regent RD
- 2690854 - Regent RD

## Hood, Grille & Dash Group

REF NO	PART NO.	QTY.	DESCRIPTION
1	1722110CSM	1	HOOD, with Louvers
2	7102326YP	1	DUCT, Air Inlet
3	1728029CSM	1	PANEL, Hood RH Side (Orange)
4	1728030CSM	1	PANEL, Hood LH Side (Orange)
5	1727297CSM	1	GRILLE, Orange
6	1727279SM	1	HINGE, Hood LH
7	1960295SM	12	CAPSCREW, Hex Flange Hd, Whizlock, 1/4-20 x 5/8
8	1930641SM	12	NUT, Hex Flange Whiz Lock, 1/4-20
9	1727293SM	1	DASHBOARD
10	1728089SM	1	KNOB, Brake Lock Plastic
11	1728090SM	1	KNOB, Cruise Lock Green Plastic
12	1960518SM	2	NUT, Push
13	1664847SM	2	SCREW, Hex Washer Head Taptite 5/16-18 x 3/4
14	1919381SM	2	WASHER, 11/32 x 1 x 1/8
15	1727999SM	1	COVER, Steering Shaft Plastic
16	1727296SM	1	HEADLIGHT ASSEMBLY
18	1960392SM	3	SCREW, Pan Head #10-24 x 1/2
19	1723123SM	1	ROD, Dash Support
20	1933896SM	3	NUT, Hex, Lock, Nylon #10-24
21	1925003SM	1	CAPSCREW, Hex Head, Taptite, 1/4-20 x 1/2
24	1732030SM	1	GUIDE, Hood LH
25	1732031SM	1	GUIDE, Hood RH
26	1735878YP	2	BRAID, Steel Insert 0-9634-219
27	1727280SM	1	HINGE, Hood RH
28	1735879YP	1	BUMPER, Front
30	1735868YP	4	BOLT, M8 x 20
31	1735989YP	4	WASHER, 8.4
32	1736000YP	4	WASHER, 8
33	1735934YP	4	NUT, M8

## Footnotes

---

### The above parts group applies to the following Mfg. Nos.:

2690849 - Regent RD  
2690850 - Regent RD  
2690853 - Regent RD  
2690854 - Regent RD

## Seat Deck & Fuel Group

NOTE: Unless noted otherwise,  
use the standard hardware torque  
specification chart.

2988773

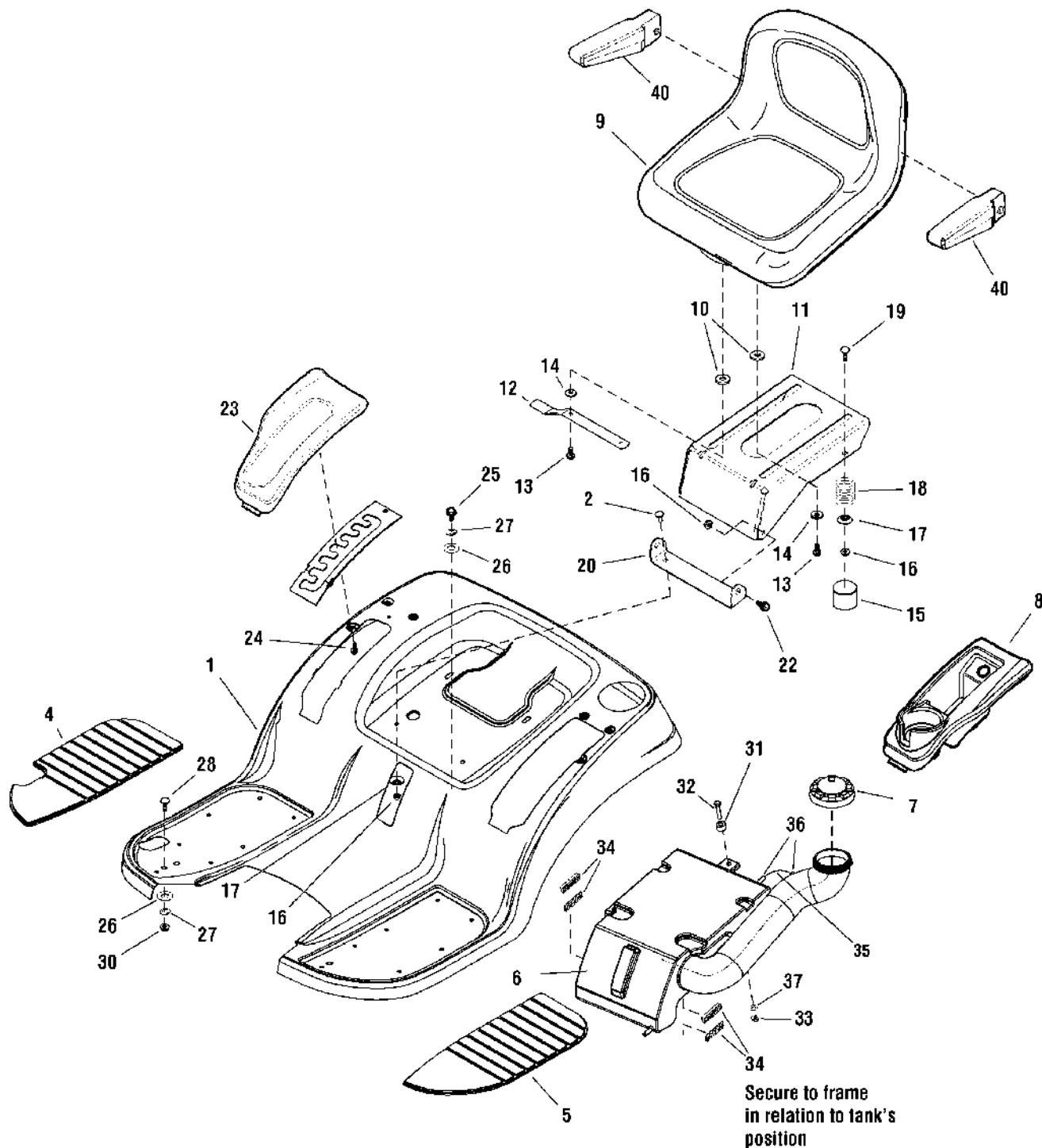

The above parts group applies to the following Mfg. Nos.:

- 2690849 - Regent RD
- 2690850 - Regent RD
- 2690853 - Regent RD
- 2690854 - Regent RD



## Seat Deck & Fuel Group

REF NO	PART NO.	QTY.	DESCRIPTION
1	1727264CSM	1	DECK, Seat w/Footrests (Orange)
2	1931333SM	2	BOLT, Carriage, 5/16-18 x 3/4, G5
4	1728007SM	1	PAD, Footrest RH
5	1728006SM	1	PAD, Footrest LH
6	1735976YP	1	TANK, FUEL 9-2770-244
7	1715917SM	1	CAP, Fuel Tank, Black Plastic
8	1729001SM	1	POD, LH Cup Holder
9	1730159SM	1	SEAT, Hi Back, Steel Pan (Used on 18HP Models)
9	1739212YP	1	SEAT, Hi Back (Used on 24HP Models)
10	1731300SM	4	SPACER, 0.32 ID x 1-1/2 OD x 3/10 THK
11	1727265SM	1	SUPPORT, Seat 12GA
12	1727268SM	1	LATCH, Seat 20GA
13	1960667SM	4	CAPSCREW, Hex Flange Whiz Lock Dog Point, 5/16-18 x 1
14	1919381SM	4	WASHER, Flat, 5/16
15	1704724SM	2	COVER, Spring
16	1960686SM	6	NUT, Hex Flange ESNA, 5/16-18, Black
17	1709256SM	4	WASHER, Spring, 5/16 x 1-1/4
18	1704728SM	2	SPRING, Compression, 2" O.D.
19	1960282SM	2	BOLT, Carriage, 5/16-18 x 3/4, G5
20	1727266SM	1	PIVOT, Seat
22	1729576SM	2	BOLT, Shoulder 5/16-18 G5
23	1729000SM	1	POD, RH Lift Quadrant
24	1960536SM	6	CAPSCREW, Hex Head, Plastite, 1/4-20 x 1/2
25	1735854YP	2	BOLT, M8 x 16
26	1735989YP	4	WASHER, 8.4
27	1736000YP	4	WASHER, 8
28	1735869YP	2	BOLT, M8 x 20
30	1735937YP	2	NUT, M8
31	1735894YP	1	SPACER, Lift 0-9521-289
32	1735867YP	1	BOLT, M6 x 30
33	1735932YP	1	NUT, M6
34	1735878YP	4	BRAID, Steel Insert 0-9634-219
35	1735914YP	1	HOSE, Air-Escape 1-9920-248
36	1736993YP	2	CLAMP
37	1735999YP	1	WASHER, 6.6
40	1687021YP	1	KIT, Arm Rest (Used on 24HP Models)

## Footnotes

---

### The above parts group applies to the following Mfg. Nos.:

2690849 - Regent RD  
2690850 - Regent RD  
2690853 - Regent RD  
2690854 - Regent RD

## Mulching Flap Group

NOTE: Unless noted otherwise,  
use the standard hardware torque  
specification chart.

2988026

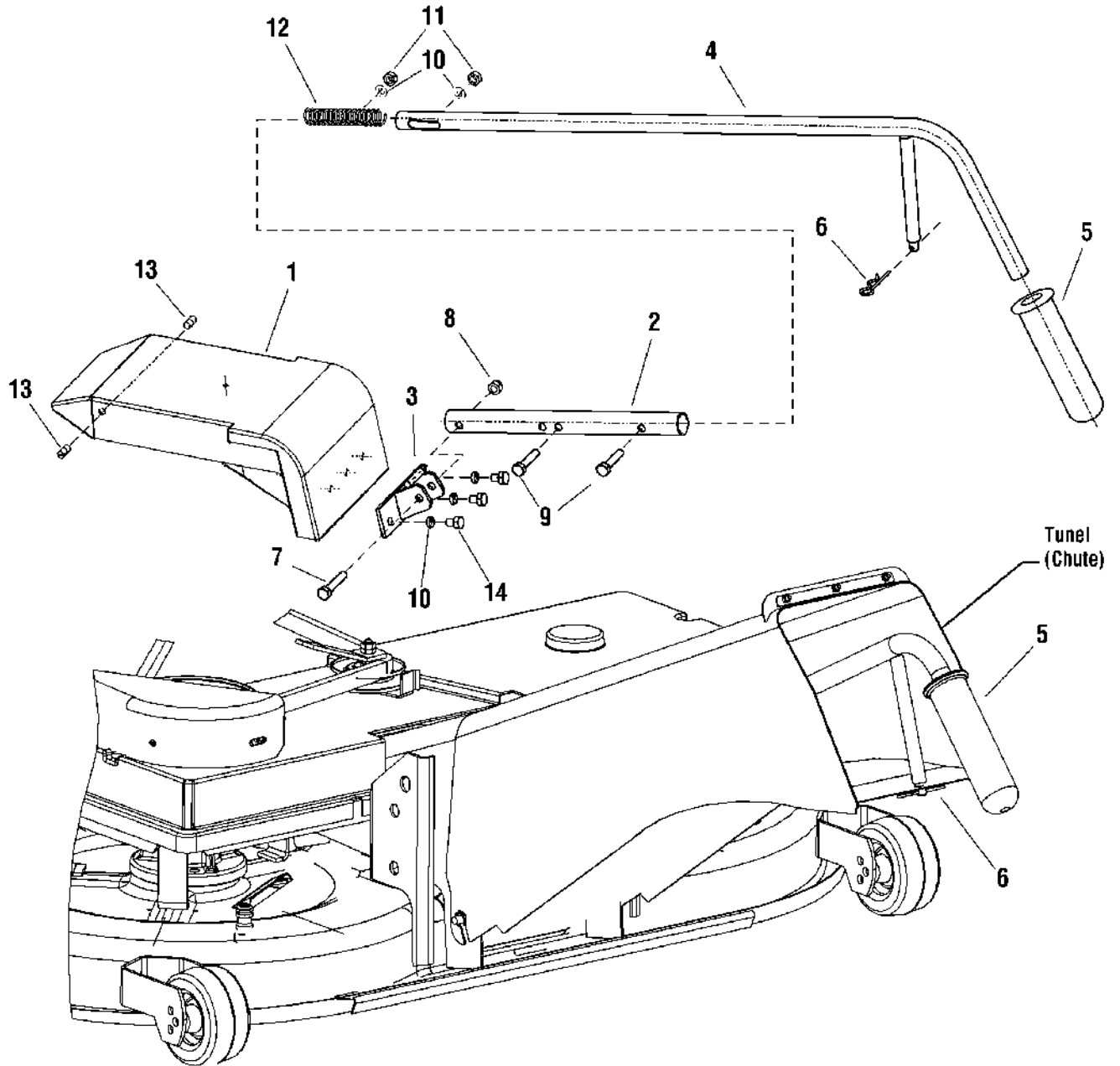

The above parts group applies to the following Mfg. Nos.:

- 2690849 - Regent RD
- 2690850 - Regent RD
- 2690853 - Regent RD
- 2690854 - Regent RD

## Mulching Flap Group

REF NO	PART NO.	QTY.	DESCRIPTION
--	1687401	1	MULCH PLUG ASSEMBLY, Complete (Includes Ref. Nos. 1-14)
1	1736134YP	1	FLANGE, Mowing 9-8547-386
2	1736133YP	1	TUBE
3	1736132YP	1	HOLDER
4	1736131YP	1	FULL TUBE
5	1736130YP	1	HANDLE, 02/20-110-RED
6	1736129YP	1	SPLIT PIN, 0-9245-240
7	1736128YP	1	SCREW, M8 x 45 CSN021103.55
8	1736127YP	1	NUT, M8 CSN021492.55
9	1736126YP	2	SCREW, M8 x 35 CSN021103.55
10	1736125YP	5	WASHER, 8 CSN021740.15
11	1736124YP	2	NUT, M8 CSN021401.55
12	1736123YP	1	SPRING, TLZ200.180.0950
13	1736122YP	2	CASING, 0-9311-816
14	1736121YP	3	SCREW, M8 x 12 CSN021103.25

Not for  
Reproduction

## Footnotes

---

### The above parts group applies to the following Mfg. Nos.:

2690849 - Regent RD  
2690850 - Regent RD  
2690853 - Regent RD  
2690854 - Regent RD

## Rear Discharge Deflector Group

1687401

NOTE: Unless noted otherwise,  
use the standard hardware torque  
specification chart.

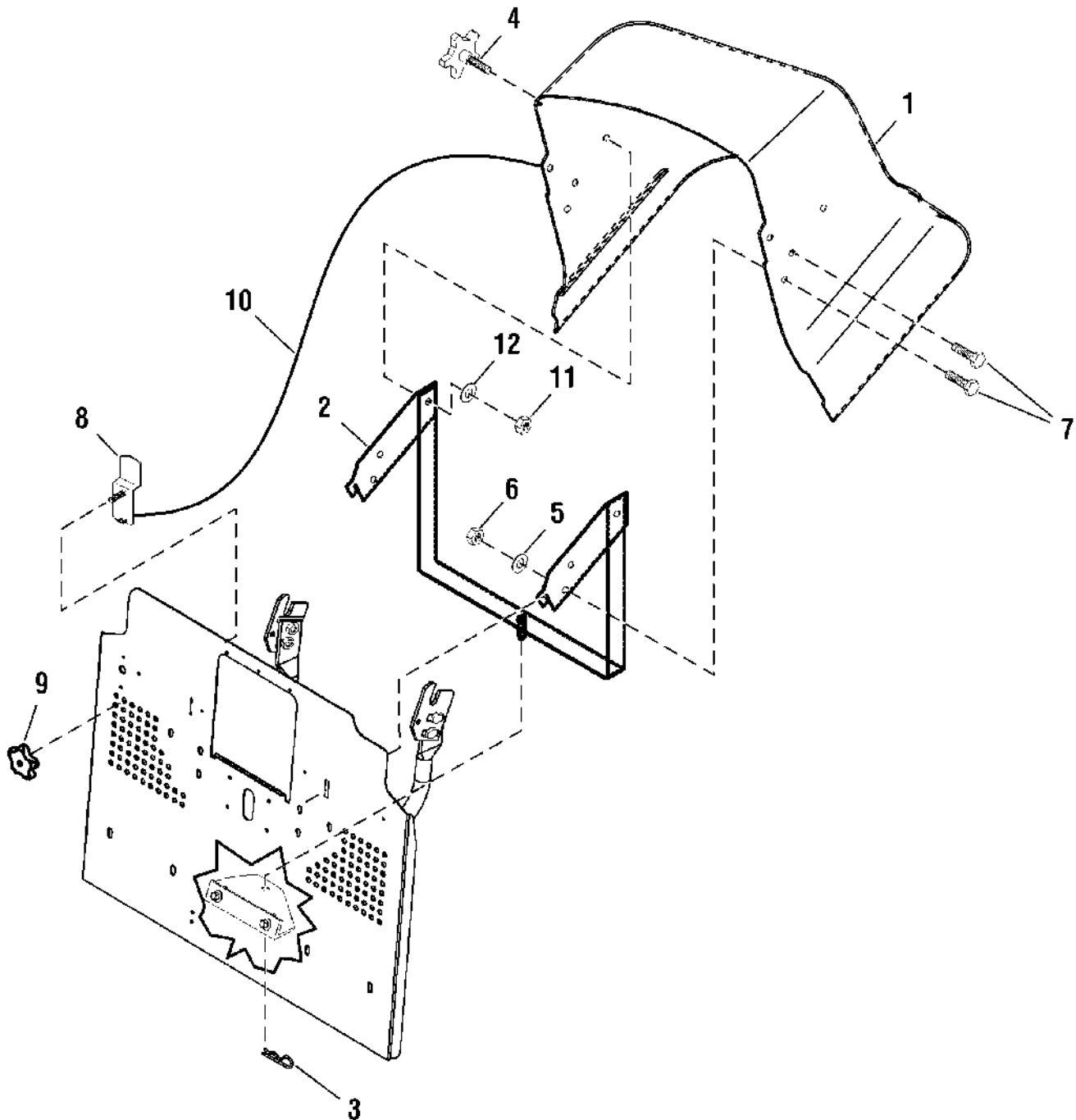

The above parts group applies to the following Mfg. Nos.:

2690849 - Regent RD  
2690850 - Regent RD  
2690853 - Regent RD  
2690854 - Regent RD

## Rear Discharge Deflector Group

REF NO	PART NO.	QTY.	DESCRIPTION
--	1687401YP	1	DEFLECTOR, Complete
1	1739710YP	1	DEFLECTOR
2	1739711YP	1	DEFLECTOR HOLDER
3	1739716YP	1	HAIR PIN
4	1739712YP	2	SCREW, With Starlike Knob
5	1735998YP	4	WASHER, 6.4
6	1736127YP	4	NUT, Selflock, M6
7	1732635YP	4	SCREW, Flat Head, M6 x 16
8	1739713YP	1	BAND
9	1739714YP	1	NUT, With Starlike Knob
10	1739715YP	1	CORD, Hair Line, 550mm
11	1735935SM	2	NUT, M8
12	1735989YP	2	WASHER, 8.4

Not for  
Reproduction

### Footnotes

---

#### The above parts group applies to the following Mfg. Nos.:

2690849 - Regent RD  
2690850 - Regent RD  
2690853 - Regent RD  
2690854 - Regent RD

# Lift Group - Manual

NOTE: Unless noted otherwise,  
use the standard hardware torque  
specification chart.

2988020

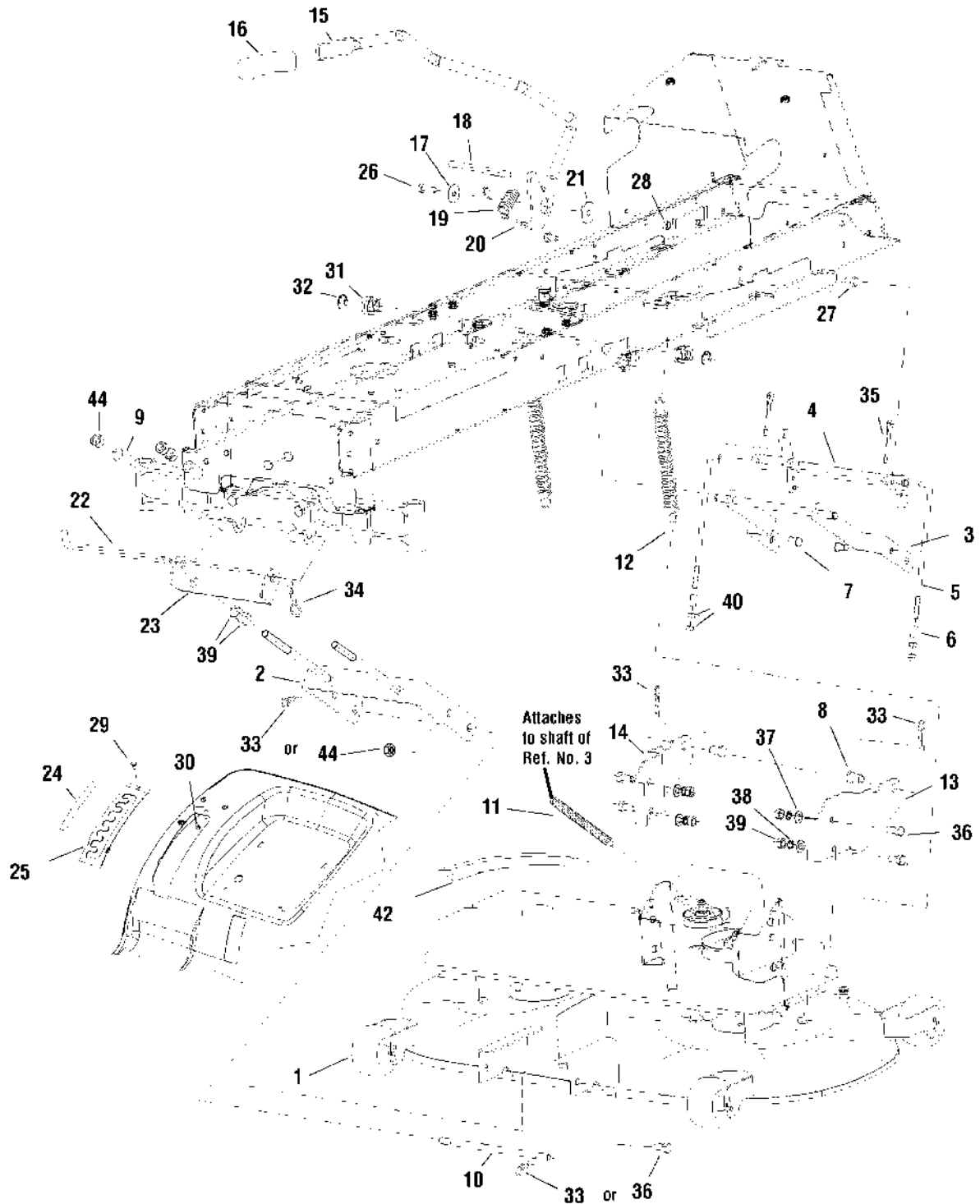

The above parts group applies to the following Mfg. Nos.:

- 2690849 - Regent RD
- 2690850 - Regent RD
- 2690853 - Regent RD
- 2690854 - Regent RD

## Lift Group - Manual

REF NO	PART NO.	QTY.	DESCRIPTION
1	1735923YP	1	MOWING MECHANISM
2	1735902YP	1	HINGE, Front
3	1735848YP	1	ARM, Lift
4	1735958YP	1	ROD, Lift
5	1735979YP	2	TIE ROD, Lift 0-8040-311
6	1735893YP	2	SPACER, Lift 0-9521-289
7	1735945YP	2	PIN, 0-9016-463
8	1735947YP	2	PIN, Mowing 1-9310-417
9	1735895YP	2	SPACER, Lift Hitch 0-9521-290
10	1735944YP	1	STUD (Used on Models Before Serial Number 2013724990)
11	1735966YP	1	SPRING, 0-9746-460
12	1735967YP	2	SPRING, 0-9746-483
13	1735898YP	1	HANDLE EXTEND BRACKET, Left
14	1735899YP	1	HANDLE EXTEND BRACKET, Right
15	1735956YP	1	ROD, Lift
16	1722302SM	1	GRIP, Black Vinyl
17	1960044SM	1	WASHER, 5/16
18	1727954SM	1	ROD, Lift, 5.43 LG
19	1729652SM	1	SPRING, Torsion
20	1728990SM	1	CLEVIS, Lift
21	1727935SM	1	SPACER, Pivot Powdered Metal
22	1731414SM	1	PIN, Hitch
23	1730221ASM	1	HANGER, Front Mower
24	1730264SM	1	DECAL, Height Of Cut
25	1727985SM	1	QUADRANT, Lift Height
26	1921333SM	1	CAPSCREW, Hex Head, 5/16-18 x 1
27	1930601SM	2	CAPSCREW, Taptite, 5/16-18 x 5/8
28	1931277SM	1	NUT, Hex Whiz Lock, 5/16-18
29	1960252SM	1	CARRIAGE BOLT, 1/4-20 x 5/8
30	1930641SM	1	NUT, Hex Flange Whiz Lock, 1/4-20
31	1735881YP	2	BUSHING, 0-9462-202
32	1735920YP	2	LOCK RING, 12
33	1735965YP	2	PIN, Flexible 0-9245-240
34	2176012SM	1	PIN, Retainer, Spring
35	1735964YP	4	SPINDLE, 3.2 x 25
36	1735856YP	2	BOLT, M12 x 25 (Used on Models After Serial Number 2013724990)
37	1735993YP	4	WASHER, 13
38	1735992YP	4	WASHER, 12
39	1735927YP	8	NUT, M12
40	1735925YP	4	NUT, M10
42	1735986YP	1	V-BELT, Li, BBT, 17 x 1200
44	1735796YP	2	NUT, M12 (Used on Models After Serial Number 2013724990)

### Footnotes

---

**The above parts group applies to the following Mfg. Nos.:**

2690849 - Regent RD  
2690850 - Regent RD  
2690853 - Regent RD  
2690854 - Regent RD

## Wheels & Tires Group

W2988024

NOTE: Unless noted otherwise,  
use the standard hardware torque  
specification chart.

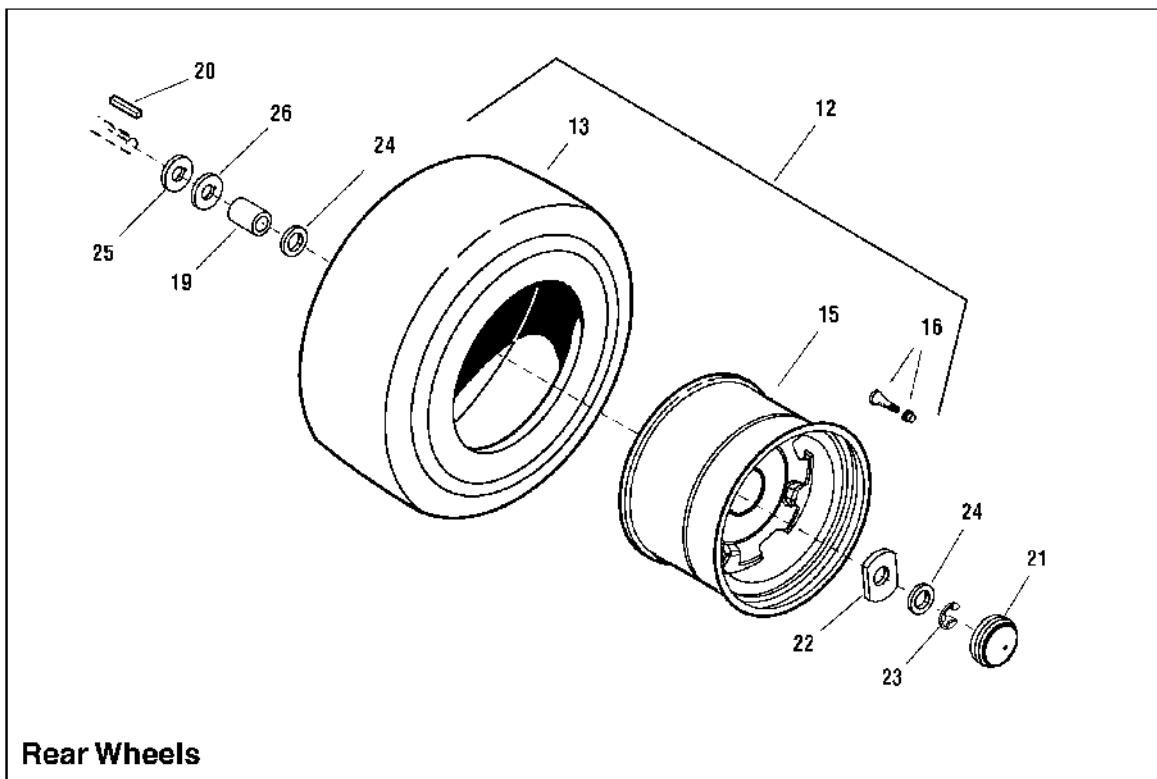
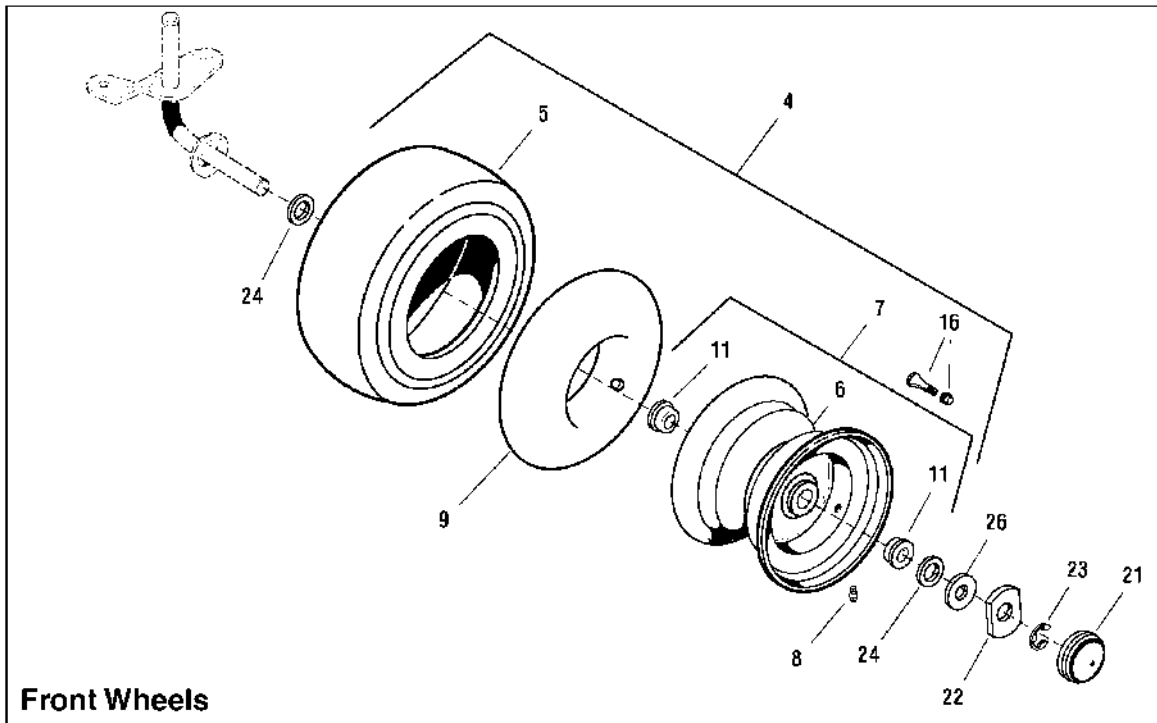

The above parts group applies to the following Mfg. Nos.:

- 2690849 - Regent RD
- 2690850 - Regent RD
- 2690853 - Regent RD
- 2690854 - Regent RD



## Wheels & Tires Group

REF NO	PART NO.	QTY.	DESCRIPTION
4	1729708SM	2	WHEEL & TIRE ASSEMBLY, Front (Includes Ref. Nos. 5, 6, 7, 8, 11 & 16)
5	1731951SM	2	TIRE, Front, K358 2 Ply, 15 x 6-6
6	-----	2	* WHEEL, Front
7	1726301SM	2	WHEEL ASSEMBLY, With Bearing (Includes Ref. Nos. 6 & 11)
8	2812808SM	2	FITTING, Grease
9	1664090	2	TUBE, Front
11	1742259YP	4	BEARING, Ball, 3/4 I.D.
12	1732324SM	2	WHEEL & TIRE ASSEMBLY, Rear 22" (Includes Ref. Nos. 13, 15 & 16)
13	1732394SM	2	TIRE, Rear, Tubeless, 22 x 10-8
15	-----	2	* WHEEL, Rear
16	2172353SM	4	VALVE STEM & CAP
19	1730181SM	2	SPACER, 0.77 ID x 1-1/4 OD x 1-5/8
20	1713409SM	2	KEY, 3/16 x 3/16 x 3
21	1722676SM	4	CAP, Hub, Gray
22	1722717SM	4	WASHER, Special Yellow
23	2827794SM	4	E-RING, Ext., 3/4 Dia.
24	2860183SM	8	WASHER, Special 3/4
25	2860202SM	2	WASHER, 3/4
26	1735988YP	8	WASHER, 3/4

Not for  
Reproduction

### Footnotes

\* Not a serviceable part, order complete Wheel & Tire assembly

---

### The above parts group applies to the following Mfg. Nos.:

2690849 - Regent RD  
2690850 - Regent RD  
2690853 - Regent RD  
2690854 - Regent RD

## Decals Group

NOTE: Unless noted otherwise, use the standard hardware torque specification chart.

2988767

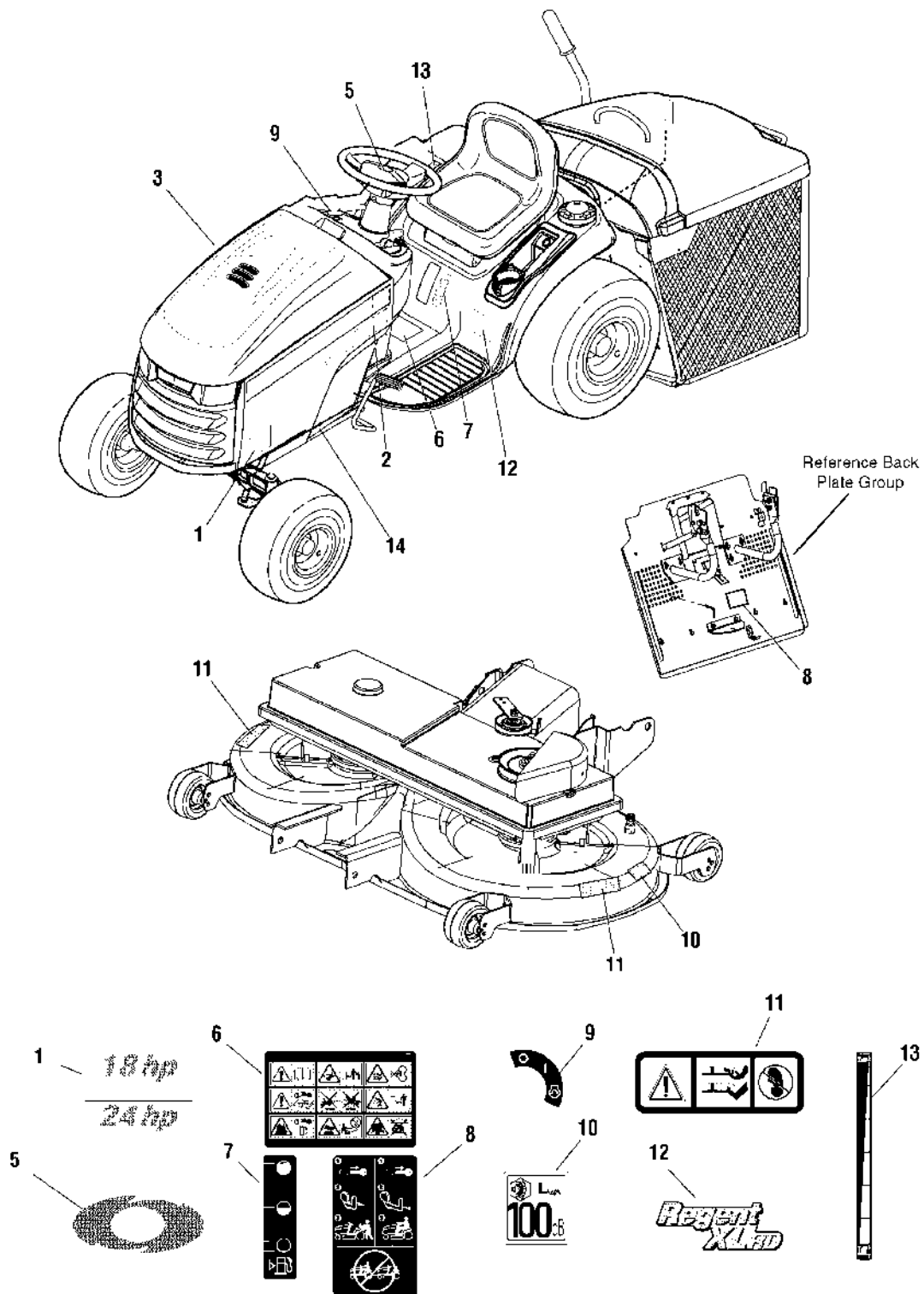

The above parts group applies to the following Mfg. Nos.:

- 2690849 - Regent RD
- 2690850 - Regent RD
- 2690853 - Regent RD
- 2690854 - Regent RD

## Decals Group

REF NO	PART NO.	QTY.	DESCRIPTION
1	1722779SM	2	DECAL, 18HP
1	1739142YP	2	DECAL, 24HP
2	1731390SM	1	DECAL, Simplicity LH Stripe
3	1731391SM	1	DECAL, Simplicity RH Stripe
5	1731418SM	1	DECAL, Simplicity Steering Wheel
6	1734027SM	1	DECAL, Tunnel
7	1735889YP	1	DECAL, Fuel level
8	1735265SM	1	DECAL, Trans/Tow Release Lever
9	1722806SM	2	DECAL, Ignition Switch White/Blk
10	1735891YP	1	DECAL, Noise
11	1735890YP	1	DECAL, Safety
12	1735542YP	1	DECAL, Regent XL RD
13	1730264SM	1	DECAL, Mower Height
14	-----	1	* DECAL, I.D. Plate

Not for  
Reproduction

### Footnotes

\* Not a serviceable part

---

### The above parts group applies to the following Mfg. Nos.:

2690849 - Regent RD  
2690850 - Regent RD  
2690853 - Regent RD  
2690854 - Regent RD

## Back Plate Group - 18HP & 24HP (After Serial Number 2013724990)

2988766

NOTE: Unless noted otherwise,  
use the standard hardware torque  
specification chart.

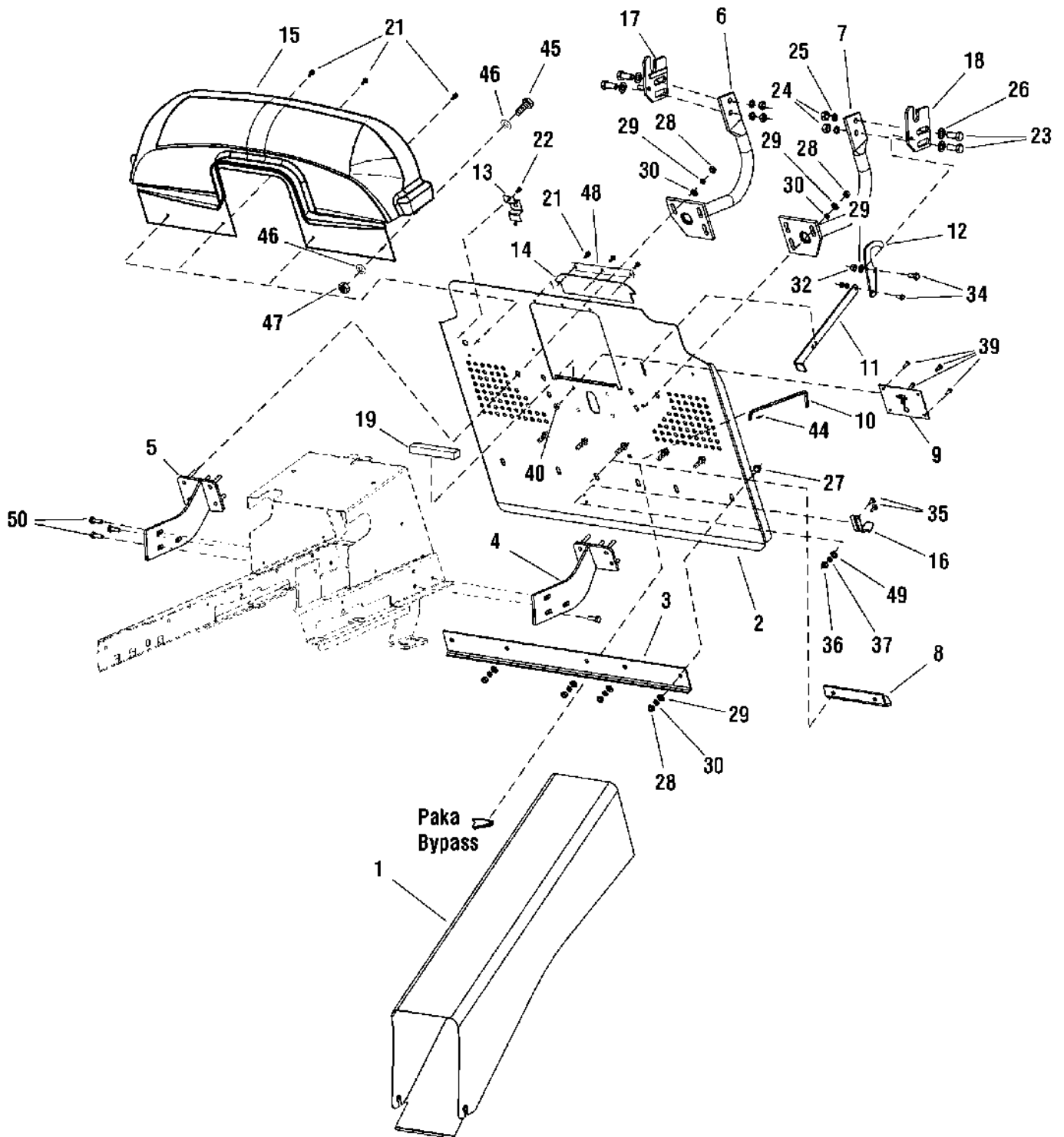

The above parts group applies to the following Mfg. Nos.:

- 2690849 - Regent RD
- 2690850 - Regent RD
- 2690853 - Regent RD
- 2690854 - Regent RD

**Back Plate Group - 18HP & 24HP (After Serial Number 2013724990)**

REF NO	PART NO.	QTY.	DESCRIPTION
1	1735985YP	1	TUNNEL
2	1735849YP	1	BACK PLATE
3	1735876YP	1	BRACE
4	1735906YP	1	HOLDER, Back Plate, L.H.
5	1735907YP	1	HOLDER, Back Plate, R.H.
6	1735908YP	1	HOLDER, Collector, R.H.
7	1735909YP	1	HOLDER, Collector, L.H.
8	1735903YP	1	HITCH
9	1735975YP	1	SWITCH, Full Collector
10	1735977YP	1	TIE ROD, Bypass 0-8045-260
11	1735978YP	1	LATCH, Tie Rod
12	1735915YP	1	LATCH
13	1735887YP	1	COVER, Switch
14	1735939YP	1	PAD, Rubber 1-1332-332
15	1735983YP	1	COVER, Plastic
16	1735970YP	1	SPRING COLLECTOR, Lock
17	1735904YP	1	HOLDER, Adjustable, Right
18	1735905YP	1	HOLDER, Adjustable, Left
19	1736998YP	1	RUBBER EDGE
21	1735961YP	6	SCREW, ST 5.5 x 19 DIN 7504-K BN1880
22	1735960YP	1	SCREW, ST 4.2 x 9.5 DIN 7504-K BN1880
23	1735857YP	4	BOLT , M12 x 30
24	1735927YP	4	NUT, M12
25	1735993YP	4	WASHER, 13
26	1735992YP	4	WASHER, 12
27	1735871YP	10	BOLT, M8 x 25 DIN 6921 8.8
28	1735934YP	12	NUT, M8
29	1735989YP	19	WASHER, 8.4
30	1736000YP	12	WASHER, 8
32	1735935YP	7	NUT, M8
34	1735868YP	1	BOLT, M8 x 40
35	1735860YP	2	BOLT, M5 x 16
36	1735930YP	2	NUT, M5
37	1735997YP	2	WASHER, 5.3
39	1739132YP	5	RIVET, Plastic
44	1735963YP	1	SPINDLE, 2 x 20
48	1739133YP	1	PAD, Steel
49	1739134YP	2	WASHER, 8.4
50	1930601SM	6	CAPSCREW, Hex Washer Head, Tapitie, 5/16-18 x 5/8

**Footnotes****The above parts group applies to the following Mfg. Nos.:**

2690849 - Regent RD  
2690850 - Regent RD  
2690853 - Regent RD  
2690854 - Regent RD

## Collector Group

NOTE: Unless noted otherwise,  
use the standard hardware torque  
specification chart.

2988007

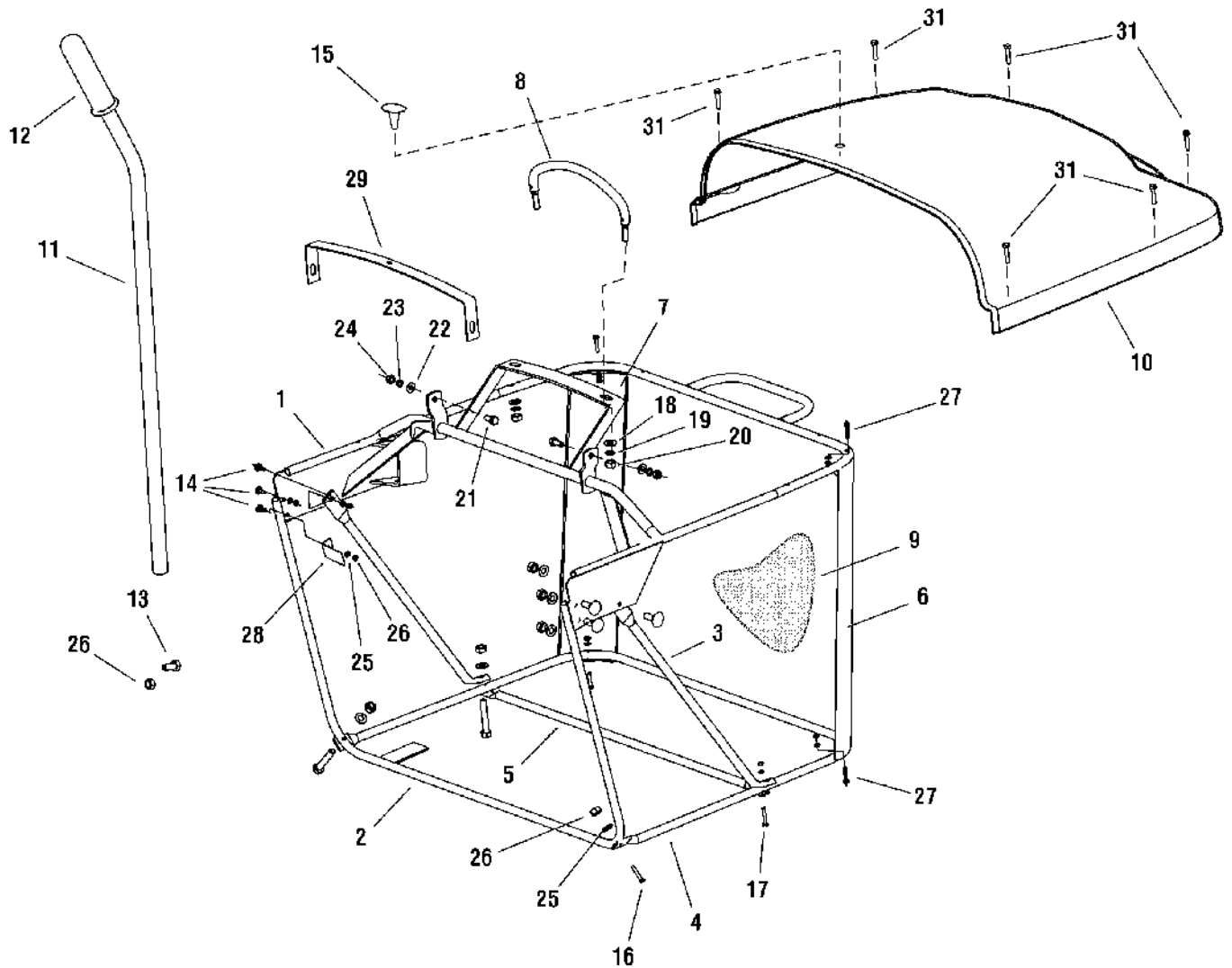

The above parts group applies to the following Mfg. Nos.:

- 2690849 - Regent RD
- 2690850 - Regent RD
- 2690853 - Regent RD
- 2690854 - Regent RD

## Collector Group

REF NO	PART NO.	QTY.	DESCRIPTION
1	1735897YP	1	FRAME, Top
2	1736463YP	1	TUBE, Front
3	1735877YP	1	BRACE
4	1735984YP	2	TUBE, Bottom
5	1735953YP	1	TUBE, Connecting
6	1736236YP	1	BRACKET, Reinforcement Left
7	1735954YP	1	BRACKET, Reinforcement Right
8	1735900YP	1	HANDLE, Full
9	1735885YP	1	FABRIC, Bagger
10	1735981YP	1	COLLECTOR, Top 0-7447-260
11	1735916YP	1	LEVER, Dumping
12	1735901YP	1	HANDLE, Rubber RC/M 25
13	1735859YP	1	BOLT, M5 x 12
14	1735860YP	1	BOLT, M5 x 16
15	1735948YP	6	PLUG, Plastic
16	1735863YP	1	BOLT, M5 x 30
17	1735864YP	2	BOLT, M5 x 35
18	1735990YP	2	WASHER, 10.5
19	1735991YP	2	WASHER, Lock 10
20	1735925YP	2	NUT, M10
21	1735868YP	2	BOLT, M8 x 20
22	1735989YP	2	WASHER, 8.4
23	1736000YP	2	WASHER, Lock 8
24	1735934YP	2	NUT, M8
25	1735997YP	2	WASHER, 5.3
26	1735931YP	14	NUT, M5
27	1735862YP	15	BOLT, M5 x 25
28	1735971YP	4	SPRING, Flat
29	1735955YP	1	BRACKET, Reinforcement, Top
31	1736416YP	1	SCREW, 6.3 x 32 DIN 7504-K
--	1737792YP	6	CATCHER ASSEMBLY (Includes Ref Nos: 1 - 31)

## Footnotes

---

### The above parts group applies to the following Mfg. Nos.:

2690849 - Regent RD  
2690850 - Regent RD  
2690853 - Regent RD  
2690854 - Regent RD

## French Guard Group

988189

NOTE: Unless noted otherwise,  
use the standard hardware torque  
specification chart.

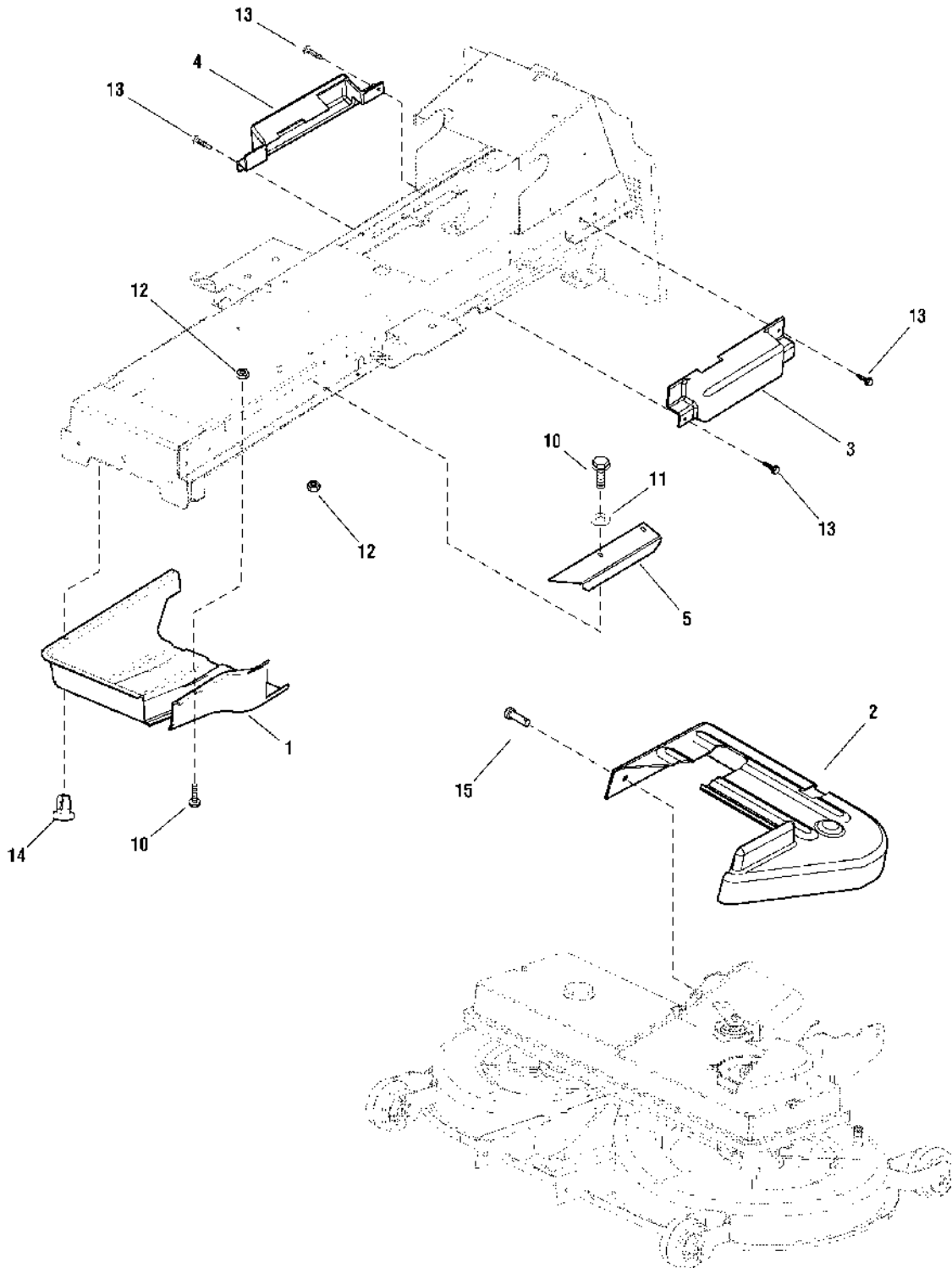

The above parts group applies to the following Mfg. Nos.:

2690853 - Regent RD

2690854 - Regent RD



## **French Guard Group**

---

<b>REF NO</b>	<b>PART NO.</b>	<b>QTY.</b>	<b>DESCRIPTION</b>
1	1737360YP	1	COVER, Clutch
2	1737361YP	1	COVER, Mower Deck
3	1737362YP	1	COVER, Roller, Left
4	1737363YP	1	COVER, Roller, Right
5	1737364YP	1	COVER, Side
10	1735859YP	6	SCREW, M5 x 12
11	1735997YP	2	WASHER
12	1735931YP	6	NUT, M5
13	1735961YP	4	SCREW, ST, 5.5 x 19
14	1737365YP	2	HOUSING
15	1737366YP	2	PIN

Not for  
Reproduction

### **Footnotes**

---

**The above parts group applies to the following Mfg. Nos.:**

2690853 - Regent RD

2690854 - Regent RD

## 40" Mower Deck - Belt & Idler Arm Group

2988004

NOTE: Unless noted otherwise,  
use the standard hardware torque  
specification chart.

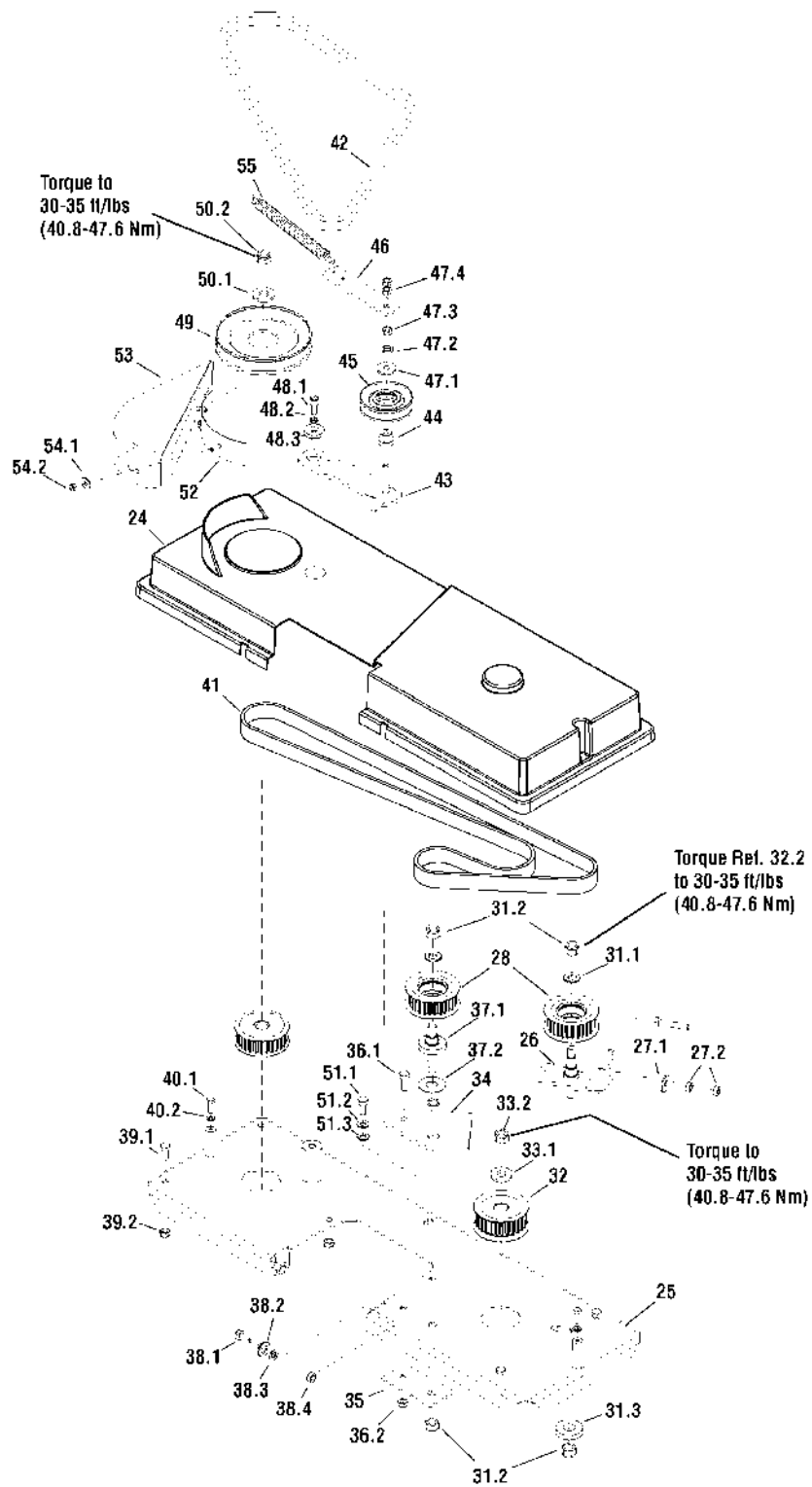

The above parts group applies to the following Mfg. Nos.:

- 2690849 - Regent RD
- 2690850 - Regent RD
- 2690853 - Regent RD
- 2690854 - Regent RD

## 40" Mower Deck - Belt & Idler Arm Group

REF NO	PART NO.	QTY.	DESCRIPTION
24	1735802YP	1	COVER, Plastic 0-8547-369
25	1735794YP	1	MAIN BOARD
26	1735787YP	1	FOOTING, Complete
27.1	1735846YP	1	WASHER, Zinc 9
27.2	1735799YP	2	NUT, M8
28	1735781YP	2	PULLEY, Belt 28 Z
31.1	1735837YP	2	WASHER, 13
31.2	1735796YP	4	NUT, M12
31.3	1735842YP	1	WASHER
32	1735784YP	2	PULLEY, Belt
33.1	1735834YP	1	WASHER 0-9220-727
33.2	1735796YP	1	NUT, M12
34	1735804YP	1	PLATE, Reinforcement
35	1735805YP	1	PLATE, Reinforcement
36.1	1735818YP	1	SCREW, M8 x 25
36.2	1735801YP	1	NUT, M8
37.1	1735827YP	1	STUD
37.2	1735841YP	1	WASHER
38.1	1735843YP	2	SCREW, Zinc M8 x 20
38.2	1735837YP	2	WASHER, 13
38.3	1735839YP	2	WASHER, 8.4
38.4	1735801YP	2	NUT, M8
39.1	1735820YP	6	SCREW, M8 x 40
39.2	1735801YP	6	NUT, M8
40.1	1735816YP	2	SCREW, M6 x 20
40.2	1735844YP	6	WASHER, Zinc 6.6
41	1735832YP	1	BELT, Two Side Tooth K+K20DS 1760
42	1735986YP	1	V-BELT, Li, BBT, 17 x 1200
43	1735790YP	1	HOLDER, Complete
44	1735826YP	1	STUD, 0-9321-263
45	1735811YP	1	ROLLER, W 3500-3712
46	1735788YP	1	FOOTING (Used on Model years 2008 and earlier)
46	1737369YP	1	FOOTING (Used on Model years 2009 and later)
47.1	1735845YP	1	WASHER, Zinc 9
47.2	1735838YP	1	WASHER, 8
47.3	1735799YP	1	NUT, M8
47.4	1735800YP	2	NUT, M8
48.1	1735817YP	1	SCREW, M8 x 20 10.9 ZN DIN 912
48.2	1735838YP	1	WASHER, 8
48.3	1735836YP	1	WASHER, 0-9221-222
49	1735782YP	1	PULLEY, Belt 9-3325-234, Complete
50.1	1735834YP	1	WASHER, 0-9220-727
50.2	1735796YP	1	NUT, M12

### Footnotes

---

**The above parts group applies to the following Mfg. Nos.:**

2690849 - Regent RD  
2690850 - Regent RD  
2690853 - Regent RD  
2690854 - Regent RD

## 40" Mower Deck - Belt & Idler Arm Group

2988004

NOTE: Unless noted otherwise,  
use the standard hardware torque  
specification chart.

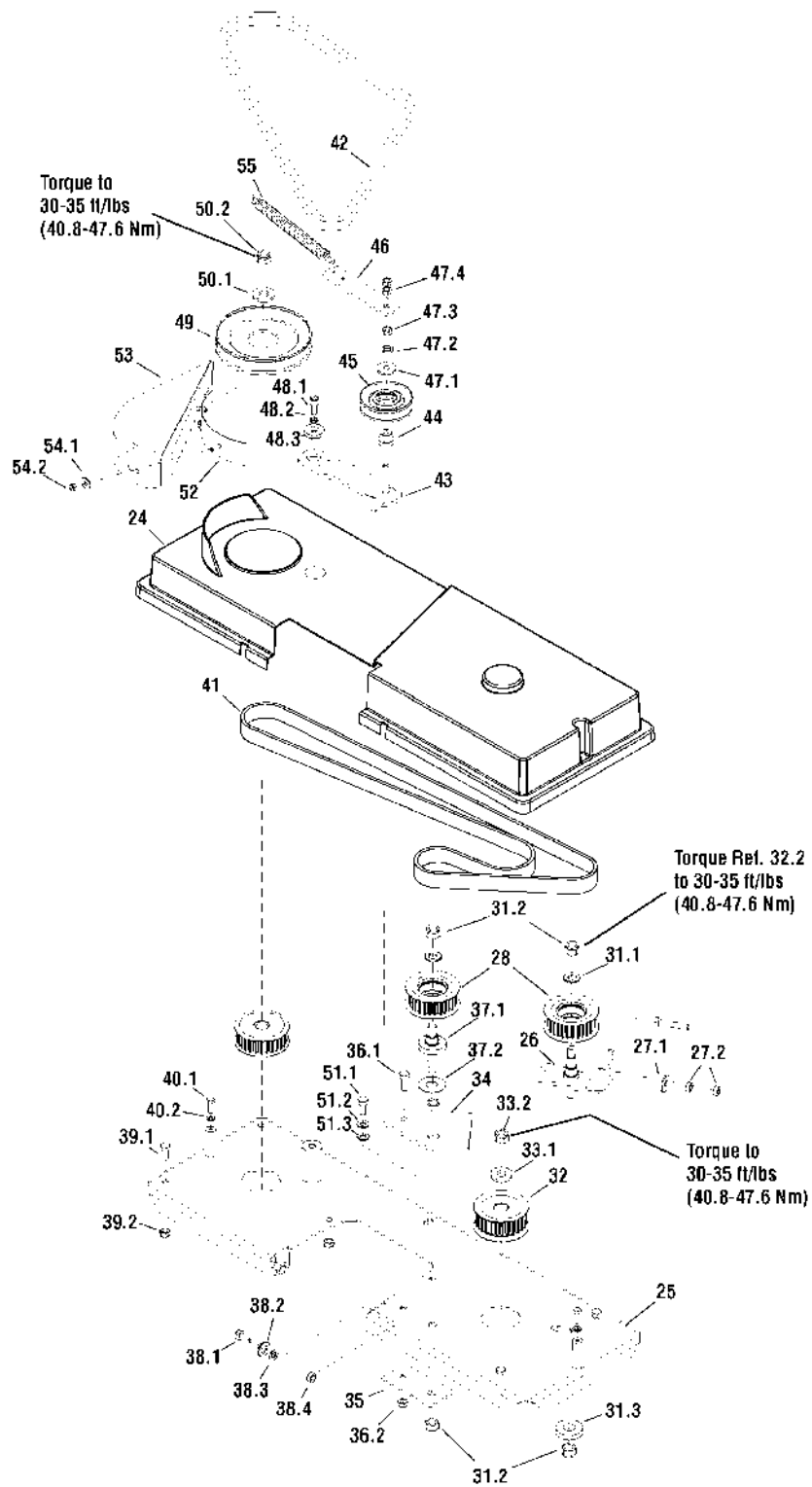

The above parts group applies to the following Mfg. Nos.:

- 2690849 - Regent RD
- 2690850 - Regent RD
- 2690853 - Regent RD
- 2690854 - Regent RD

## 40" Mower Deck - Belt & Idler Arm Group

REF NO	PART NO.	QTY.	DESCRIPTION
51.1	1735820YP	1	SCREW, M8 x 40
51.2	1735838YP	1	WASHER, 8
51.3	1735839YP	1	WASHER, 8.4
52	1735806YP	1	PLATE, Reinforcement
53	1735783YP	1	COVER, Pulley, Belt 0-8534-203
54.1	1735844YP	2	WASHER, Zinc 6.6
54.2	1735798YP	2	NUT, M6
55	1735825YP	1	SPRING, 0-9746-460

Not for  
Reproduction

### Footnotes

---

**The above parts group applies to the following Mfg. Nos.:**

2690849 - Regent RD  
2690850 - Regent RD  
2690853 - Regent RD  
2690854 - Regent RD

# 40" Mower Deck - Housing, Hitch, Arbors & Blades Group

2988005

NOTE: Unless noted otherwise,  
use the standard hardware torque  
specification chart.

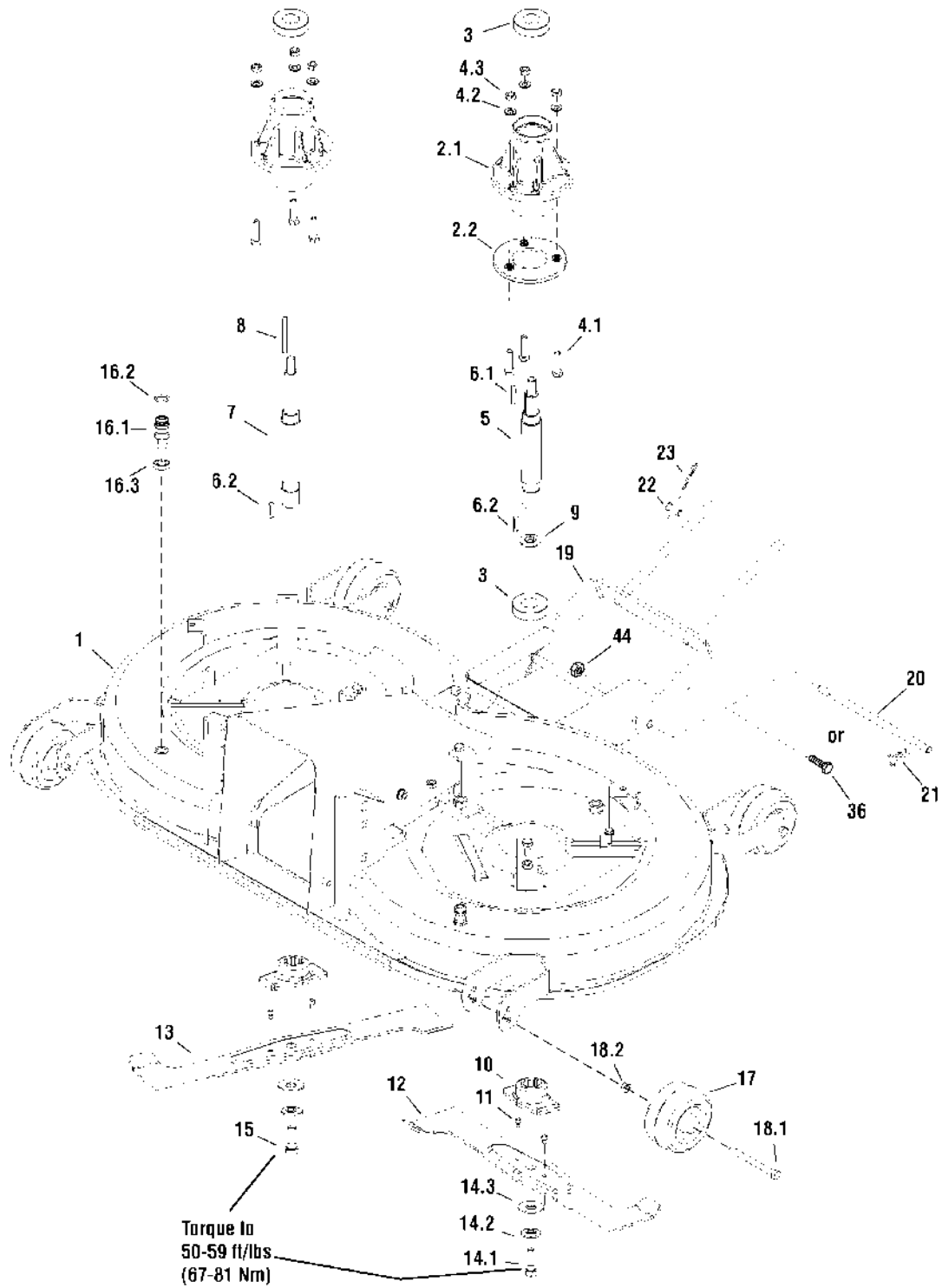

The above parts group applies to the following Mfg. Nos.:

- 2690849 - Regent RD
- 2690850 - Regent RD
- 2690853 - Regent RD
- 2690854 - Regent RD

## 40" Mower Deck - Housing, Hitch, Arbors & Blades Group

REF NO	PART NO.	QTY.	DESCRIPTION
1	1735888YP	1	MOWER DECK, Complete
2.1	1735791YP	2	HOUSING
2.2	1735807YP	2	REINFORCEMENT
3	1735780YP	4	BEARING 6205 2 RS C 66IB
4.1	1735819YP	6	SCREW, M8 x 35
4.2	1735839YP	6	WASHER, 8.4
4.3	1735801YP	6	NUT, M8
5	1735823YP	1	SHAFT
6.1	1735830YP	1	TONGUE, 6 H 9 x 6 x 30
6.2	1735829YP	2	TONGUE, 6 H 9 x 6 x 25
7	1735822YP	1	SHAFT
8	1735831YP	1	TONGUE, 6 H 9 x 6 x 63
9	1735812YP	2	RING, Safety 25
10	1735792YP	2	HOUSING
11	1735824YP	4	SHEAR STUD 0-9311-736
12	1735809YP	1	BLADE, Right Rotary
13	1735793YP	1	BLADE, Left Rotary
14.1	1735815YP	1	SCREW, M10, 0-9011-287
14.2	1735835YP	2	WASHER
14.3	1735840YP	2	WASHER, BN 806-40 x 16.3 x 2 x 3.1
15	1735814YP	1	SCREW, Left Thread, M10, 0-9011-283
16.1	1735803YP	2	QUICK FASTENER 0-9026-246
16.2	1735810YP	2	RING 13 x 2 NBR
16.3	1735797YP	2	NUT, M12
17	1735808YP	4	CUTTING WHEEL, Right ETOP 100-8.2
18.1	1735821YP	4	SCREW, M8 x 90
18.2	1735801YP	4	NUT, M8
19	1735902YP	1	HINGE, Front
20	1735944YP	1	STUD (Used on Models Before Serial Number 2013724990)
21	1735965YP	4	PIN, Flexible 0-9245-240 (Used on Models Before Serial Number 2013724990)
22	1735795YP	2	MOWING STUD 1-9310-290
23	1735786YP	4	PIN, Flexible 0-9245-999
36	1735856YP	2	BOLT, M12 x 25 (Used on Models After Serial Number 2013724990)
44	1735796YP	2	NUT, M12 (Used on Models After Serial Number 2013724990)

### Footnotes

---

#### The above parts group applies to the following Mfg. Nos.:

2690849 - Regent RD  
2690850 - Regent RD  
2690853 - Regent RD  
2690854 - Regent RD

Not for  
Reproduction



Not for  
Reproduction

Not for  
Reproduction

# Hardware Identification & Torque Specifications

Torque Specification Chart								
FOR STANDARD METRIC MACHINE HARDWARE (Tolerance ± 20%)								
Property Class	5.6		8.8		10.9		12.9	
	Class 5.6		Class 8.8		Class 10.9		Class 12.9	
Size Of Hardware	in/lbs	Nm.	in/lbs	Nm.	in/lbs	Nm.	in/lbs	Nm.
	ft/lbs		ft/lbs		ft/lbs		ft/lbs	
M3	5.88	.56	13.44	1.28	19.2	1.80	22.92	2.15
M4	13.44	1.28	30.72	2.90	43.44	4.10	52.56	4.95
M5	26.4	2.50	60.96	5.75	5.97	8.10	7.15	9.7
M6	44.64	4.3	7.3	9.9	10.3	14	12.1	16.5
M7	5.2	7.1	12.1	16.5	16.9	23	19.9	27
M8	7.7	10.5	17.7	24	25	34	29	40
M10	15	21	35	48	50	67	59	81
M12	26	36	61	83	86.2	117	103	140
M14	42	58	101	132	136	185	162	220
M16	64	88	147	200	210	285	250	340
M18	89	121	202	275	287	390	346	470
M20	126	171	290	390	405	550	486	660
M22	169	230	390	530	559	745	656	890
M24	217	295	497	375	708	960	840	1140
M27	320	435	733	995	1032	1400	1239	1680
M30	435	590	995	1350	1401	1900	1681	2280
M33	590	800	1349	1830	1902	2580	2278	3090
M36	759	1030	1740	2360	2441	3310	2935	3980
M39	988	1340	2249	3050	3163	4290	3798	5150

Torque Specification Chart						
FOR STANDARD MACHINE HARDWARE (Tolerance ± 20%)						
Hardware Grade	No Marks		SAE Grade 5		SAE Grade 8	
	SAE Grade 2		SAE Grade 5		SAE Grade 8	
Size Of Hardware	in/lbs	Nm.	in/lbs	Nm.	in/lbs	Nm.
	ft/lbs		ft/lbs		ft/lbs	
8-32	19	2.1	30	3.4	41	4.6
8-36	20	2.3	31	3.5	43	4.9
10-24	27	3.1	43	4.9	60	6.8
10-32	31	3.5	49	5.5	68	7.7
1/4-20	66	7.6	8	10.9	12	16.3
1/4-28	76	8.6	10	13.6	14	19.0
5/16-18	11	15.0	17	23.1	25	34.0
5/16-24	12	16.3	19	25.8	29	34.0
3/8-16	20	27.2	30	40.8	45	61.2
3/8-24	23	31.3	35	47.6	50	68.0
7/16-14	30	40.8	50	68.0	70	95.2
7/16-20	35	47.6	55	74.8	80	108.8
1/2-13	50	68.0	75	102.0	110	149.6
1/2-20	55	74.8	90	122.4	120	163.2
9/16-12	65	88.4	110	149.6	150	204.0
9/16-18	75	102.0	120	163.2	170	231.2
5/8-11	90	122.4	150	204.0	220	299.2
5/8-18	100	136	180	244.8	240	326.4
3/4-10	160	217.6	260	353.6	386	525.0
3/4-16	180	244.8	300	408.0	420	571.2
7/8-9	140	190.4	400	544.0	600	816.0
7/8-14	155	210.8	440	598.4	660	897.6
1-8	220	299.2	580	788.8	900	1,244.0
1-12	240	326.4	640	870.4	1,000	1,360.0

The guides and ruler furnished below are designed to help you select the appropriate hardware.



Nut, M8

Thread Diameter (mm)  
Inside Diameter (in)  
Threads per inch

Nut, 1/2-16

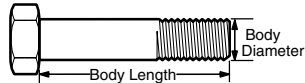

Screw, M8- 1.25 x 25

Thread Diameter (mm)  
Body Diameter  
Distance between threads (mm)  
Threads per inch  
Body Length (mm)  
Body Length (in)

Screw, 1/2- 16 x 2

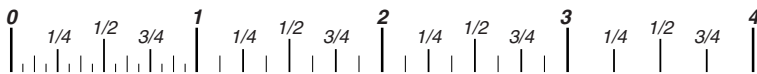

## Standard Hardware Sizing

When a washer or nut is identified as **1/2"** (M8), this is the *Nominal size*, meaning the *inside diameter* is 1/2 inch (8mm metric thread diameter); if a second number is present it represents the *threads per inch* (distance between threads).

When bolt or capscrew is identified as **1/2 - 16 x 2"** (M8 - 1.25 x 50), this means the *Nominal size*, or body diameter is 1/2 inch (8mm metric thread diameter), the second number, 16, represents the *threads per inch*, (1.25 thread diameter). The final number is the body length of the bolt or screw, 2 inches (50mm).

## NOTES

- These torque values are to be used for all hardware excluding: locknuts, self-tapping screws, thread forming screws, sheet metal screws and socket head setscrews.
- Recommended seating torque values for locknuts:
  - for prevailing torque locknuts - use 65% of grade 5 torques.
  - for flange whizlock nuts and screws - use 135% of grade 5 torques.
- Unless otherwise noted on assembly drawings, all torque values must meet this specification.

## Common Hardware Types

Hex Head Capscrew



Washer



Lockwasher

Carriage Bolt



Hex Nut

## Wrench & Fastener Size Guide

1/4" Bolt or Nut Wrench—7/16"	5/16" Bolt or Nut Wrench—1/2"	3/8" Bolt or Nut Wrench—9/16"	7/16" Bolt or Nut Wrench (Bolt)—5/8" Wrench (Nut)—11/16"	1/2" Bolt or Nut Wrench—3/4"
M6 Bolt or Nut Wrench—10mm	M8 Bolt or Nut Wrench—13mm	M10 Bolt or Nut Wrench—17mm	M12 Bolt or Nut Wrench—19mm	M14 Bolt or Nut Wrench—22mm

Not for  
Reproduction

**IT IS THE POLICY OF BRIGGS & STRATTON CORP. TO IMPROVE ITS PRODUCTS  
WHENEVER IT IS POSSIBLE AND PRACTICAL TO DO SO. WE RESERVE THE RIGHT TO  
MAKE CHANGES OR ADD IMPROVEMENTS AT ANY TIME WITHOUT INCURRING ANY  
OBLIGATION TO MAKE SUCH CHANGES ON PRODUCTS.**

**Briggs & Stratton Yard Power Products Group**

---

3515 N. 124 Street / PO Box 702  
Wauwatosa, WI 53222 USA

[www.simplicitymfg.com](http://www.simplicitymfg.com)

© Copyright 2010 by Briggs & Stratton Corporation  
Milwaukee, WI, USA. All rights reserved