

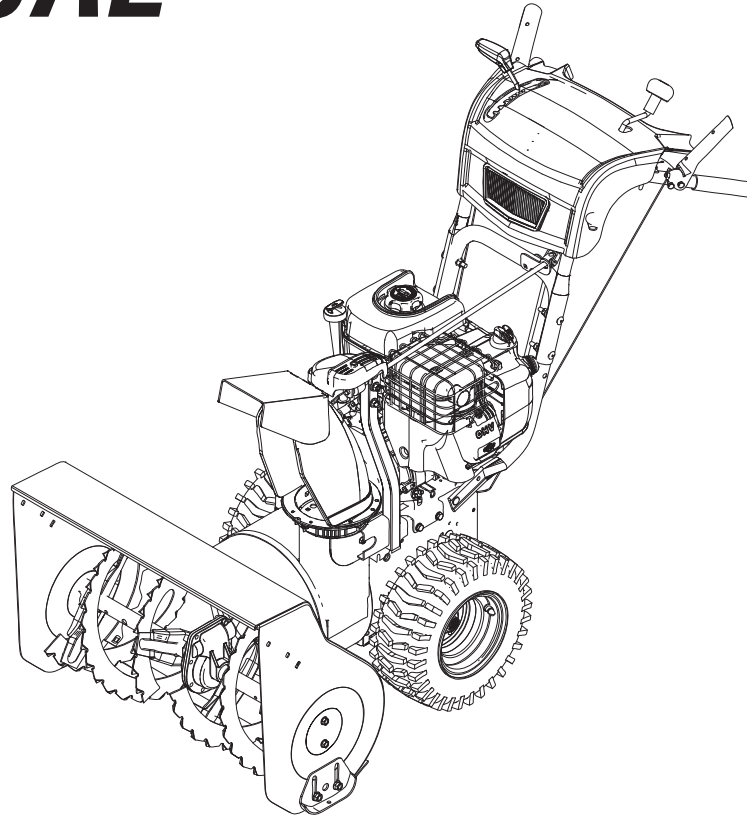

PARTS MANUAL



Models

Mfg. No.	Description
1696062-01	MM741450E, Murray 14.5TP 29" Dual Stage Snowthrower (CE) (2012)
1696200-00	MM691150E, Murray 11.5TP 27" Dual Stage Snowthrower (CE) (2012)

Manual Part No. 1755614
Revision -
Rev. Date: 7/13/2012

Not for
Reproduction

PRODUCT COMPONENTS	PAGES
Handles & Controls Group	4
Engine Group	8
Auger Drive Group	12
Auger Housing Group	14
Traction Drive Group - Standard	16
Wheels & Tires Group	18
Decals Group 2990614_2990694)	20
Gear Case Assembly	22
Discharge Chute	24
Torque Specification Chart	Inside Back Cover

Not for
Reproduction

Handles & Controls Group

NOTE: Unless noted otherwise,
use the standard hardware torque
specification chart.

2989759

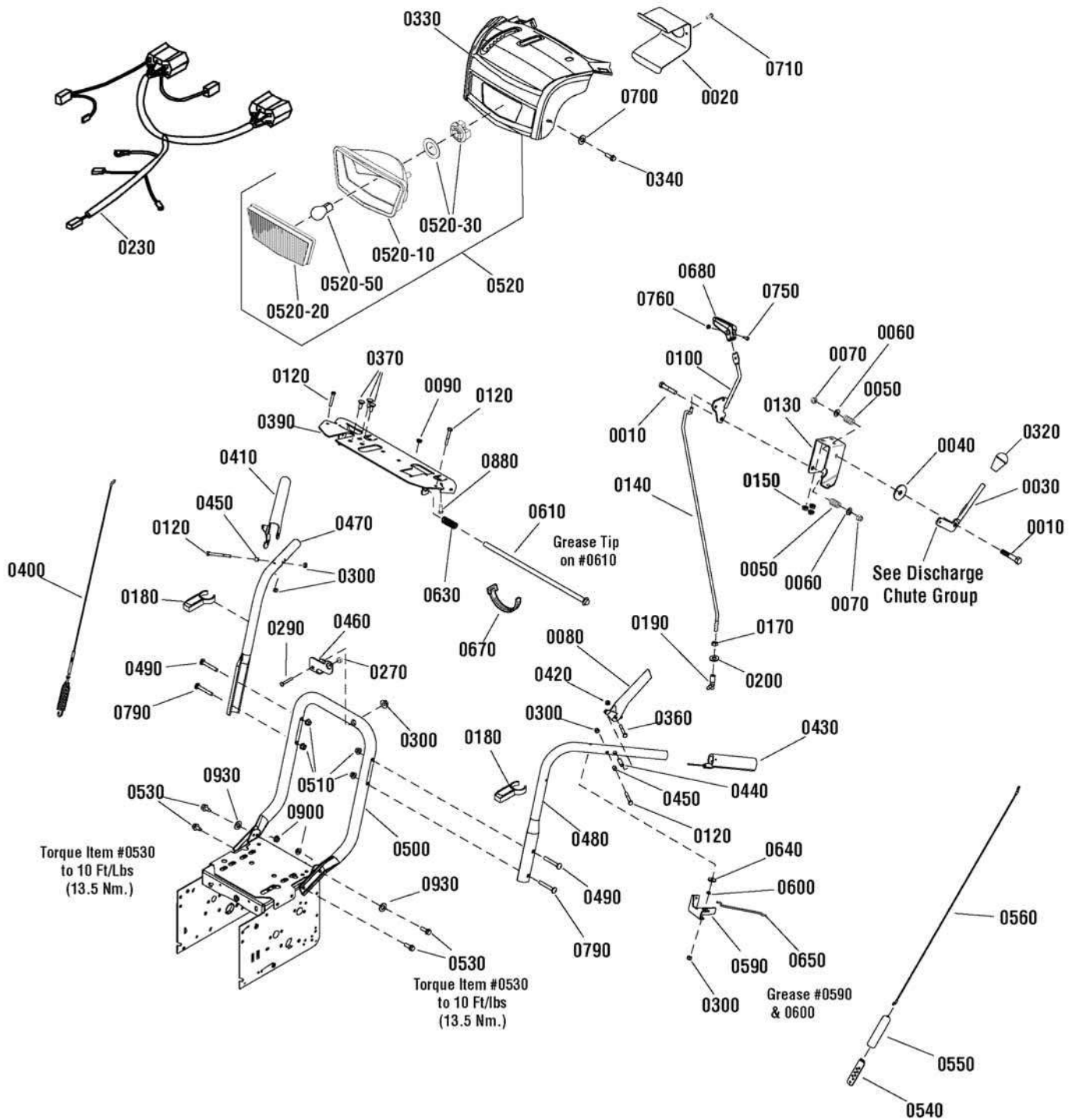

The above parts group applies to the following Mfg. Nos.:

1696062-01 - MM741450E

1696200-00 - MM691150E

Handles & Controls Group

REF NO	PART NO.	QTY.	DESCRIPTION
0010	1923701SM	2	CAPSCREW, Hex Head, 3/8-16 x 2, GR5
0020	1736305AYP	1	BRACKET, Light Mount
0030	1736192YP	1	LEVER, Deflector
0040	1924356SM	1	WASHER, 3/8
0050	50786MA	2	SPRING, 3/4"
0060	1918266SM	2	WASHER, 3/8
0070	1919439SM	2	NUT, Hex Lock, ESNA LIGHT, 3/8-16
0080	1739782AYP	1	LEVER, Clutch, LH
0090	1667588SM	1	BUSHING, 3/8 ID x 7/16 OD x 2
0100	1736836YP	1	SPEED LEVER
0120	1921962SM	4	CAPSCREW, Hex Head, 1/4-20 x 1-3/4, GR5
0130	1737684YP	1	BRACKET, Controls
0140	1734354SM	1	ROD, 25"
0150	1931277SM	3	NUT, Hex Flange, Whiz Lock, 5/16-18
0170	2820263SM	2	NUT, Hex, 5/16-24
0180	1739510YP	2	BRACKET, Lower Mounting
0190	1739290YP	1	BALLJOINT, Quick Release
0200	1917356SM	1	LOCKWASHER, Spring, 5/16
0230	1738286YP	1	WIRING HARNESS
0270	1501874MA	1	BUSHING, Chute Crank
0290	1931323SM	1	BOLT, Carriage, Short Neck, 1/4-20 x 2, G5
0300	1920397SM	5	NUT, Hex Lock, ESNA LIGHT, 1/4-20
0320	1732470SM	1	KNOB, Deflector
0330	1736345YP	1	DASH ASSEMBLY, Light
0340	1960001SM	2	SCREW, Hex Washer Head, Plastite, 10-14 x 5/8
0360	1750554YP	2	BOLT, Shoulder, 1/4 x 1-1/4
0370	1931333SM	3	BOLT, Carriage, 5/16-18 x 3/4, G5
0390	1739500AYP	1	SUPPORT, Dash
0400	1737544YP	1	CABLE, Auger Drive
0410	1739783AYP	1	LEVER, Clutch, RH
0420	1933896SM	2	NUT, Hex Lock, Nylon Insert, 10-24
0430	1726317SM	2	GRIP
0440	1736542YP	2	SPACER, Stepped
0450	1678392SM	2	SPACER, 1/4 ID x 3/8 OD x 5/16"
0460	1735589YP	1	BRACKET, Rod Support
0470	1734587ASM	1	HANDLE, Upper, RH
0480	1734586ASM	1	HANDLE, Upper, LH
0490	1960273SM	2	BOLT, Carriage, Short Neck, 5/16-18 x 2-1/4, GR5
0500	1737274AYP	1	HANDLE, Lower
0510	1739305YP	4	NUT, Hex Flange, ESNA, 5/16-18
0520	1736208YP	1	HEADLIGHT ASSEMBLY
0520-10	----	1	DEFLECTOR, Light (Included with Ref. No. 0520)

Footnotes

Note* See your local hardware store for replacement bulbs.

The above parts group applies to the following Mfg. Nos.:

1696062-01 - MM741450E

1696200-00 - MM691150E

Handles & Controls Group

NOTE: Unless noted otherwise,
use the standard hardware torque
specification chart.

2989759

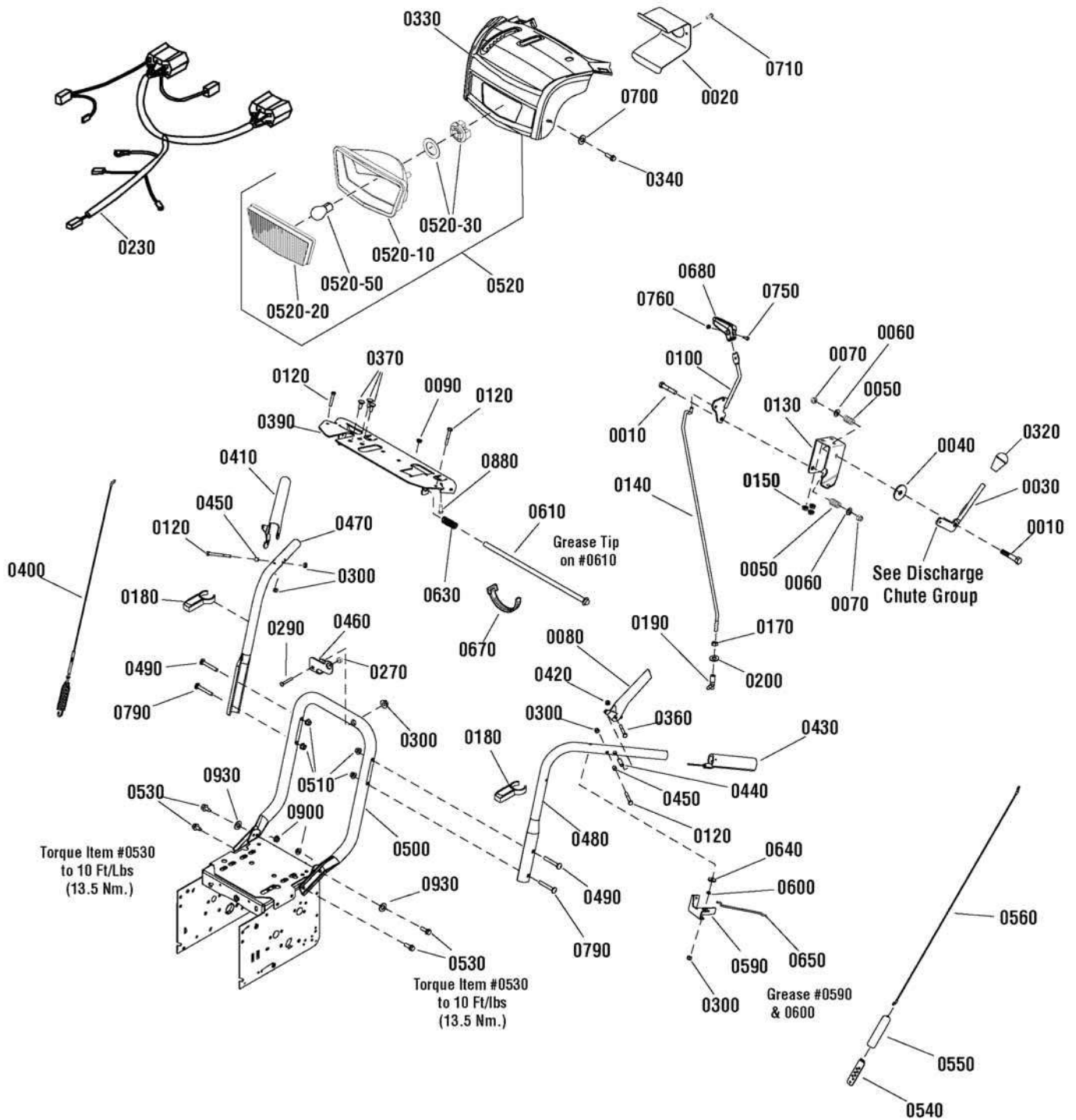

The above parts group applies to the following Mfg. Nos.:

1696062-01 - MM741450E

1696200-00 - MM691150E

Handles & Controls Group

REF NO	PART NO.	QTY.	DESCRIPTION
0520-20	----	1	LENS (Included with Ref. No. 0520)
0520-30	1736180YP	1	SOCKET & GASKET ASSEMBLY, Headlight (Included with Ref. No. 0520)
0520-50	-----	1	* BULB, Light, 12V 15W, 1156 (Included with Ref. No. 0520)
0530	1931333SM	4	BOLT, Carriage, 5/16-18 x 3/4, GR5
0540	313441MA	1	BRACKET, Cable Adjusting
0550	308146MA	1	BOOT, Spring End Cover
0560	1502113MA	1	CABLE, Front Drive
0590	1733505ASM	1	BRACKET, Pivot, Free Hand
0600	1733095SM	3	SPACER, 1/4 ID x 3/8 OD x 1/8"
0610	1736363YP	1	ROD & SPRING ASSEMBLY
0630	2108360SM	1	SPRING, Compression
0640	1960353SM	1	WASHER, 1/4
0650	1736360YP	1	ROD, Hold Down, 5-1/2"
0670	1701011SM	5	TIE, Self Lock
0680	1733192SM	1	KNOB, Slot Speed
0700	1921319SM	2	WASHER, 1/4
0710	316042MA	2	SCREW, Hex Washer Head, #10-HL x 5/8
0750	1960589SM	1	SCREW, Round Head Phillips, #10-24 x 3/4
0760	7091290SM	1	NUT, Hex Lock, Nylon, #10C
0790	1931338SM	2	BOLT, Carriage, Short Neck, 5/16-18 x 1-3/4, GR5
0880	7091081SM	2	SCREW, Hex Washer, Self Tap, 1/4-15 x 3/4
0900	1739305YP	4	NUT, Hex Flange, ESNA, 5/16-18
0930	71071MA	2	WASHER, Flat

Footnotes

Note* See your local hardware store for replacement bulbs.

The above parts group applies to the following Mfg. Nos.:

1696062-01 - MM741450E

1696200-00 - MM691150E

Engine Group

NOTE: Unless noted otherwise, use the standard hardware torque specification chart.

2989770

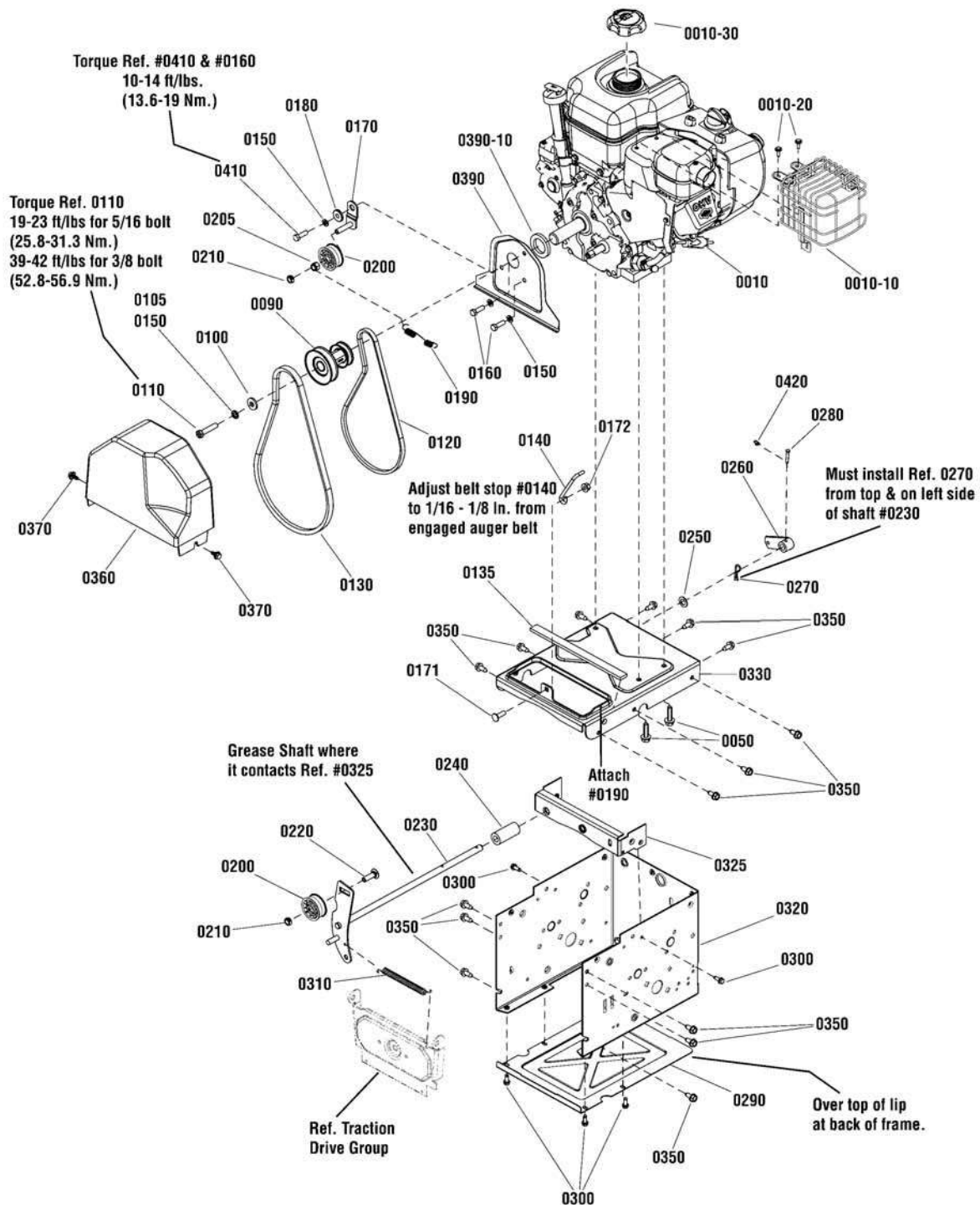

The above parts group applies to the following Mfg. Nos.:

1696062-01 - MM741450E

Engine Group

REF NO	PART NO.	QTY.	DESCRIPTION
0010	15C107-0171-F8	1	* ENGINE, 11.5TP Briggs & Stratton (Engine Model: 15C107-0171-F8)
0010	20M314-0140-H1	1	* ENGINE, 14.5TP Briggs & Stratton (Engine Model: 20M314-0140-H1)
0010-10	793193	1	GUARD, Muffler (Use on 11.5TP Models)
0010-10	796384	1	GUARD, Muffler (Use on 14.5TP Models)
0010-20	699854	3	SCREW, Muffler Guard (Use on 11.5TP Models)
0010-20	699231	4	SCREW, Hex Washer Thread Rolling (Use on 14.5TP Models)
0010-30	792647	1	CAP, Fuel
0050	75246GS	4	SCREW, Hex Head, Trilobular, 3/8-16 x 1-1/4
0090	1739514YP	1	PULLEY ASSEMBLY
0100	1919381SM	1	WASHER, 5/16 (Use on 11.5TP Models)
0100	1922755SM	1	WASHER, Flat, 1/2 (Use on 14.5TP Models)
0105	1916965SM	1	LOCKWASHER, Spring, 3/8 (Use on 14.5TP Models)
0110	1441MA	1	BOLT, Hex, 5/16-24 x 1-3/4 (Use on 11.5TP Models)
0110	2860768YP	1	CAPSCREW, Hex Head, 3/8-24 x 1-3/4, G8 (Use on 14.5TP Models)
0120	1733324SM	1	V-BELT, Traction Drive, 3L 33.13
0130	585416MA	1	BELT, Auger, V4L 38.10 MF 05-10
0135	1750314YP	1	SEAL, Strip
0140	1737377YP	1	STOP, Belt
0150	1917356SM	3	LOCKWASHER, Spring (Qty 4 used on 11.5TP Models)
0160	1921515SM	2	CAPSCREW, Hex Head, 5/16-24 x 3/4, G5
0170	1739846YP	1	BRACKET, Idler
0171	1931335SM	1	BOLT, Carriage, 5/16-18 x 1, G5
0172	1960684SM	1	NUT, Hex KEPS, 5/16-18
0180	1501065MA	1	BUSHING, Idler Bracket
0190	165X164MA	1	SPRING, Extension, Idler
0200	1502120MA	2	IDLER, Plastic Ball Bearing
0205	7091299SM	1	NUT, Nylock, 3/8-16
0210	1960251SM	2	NUT, Hex Centerlock Jam, 3/8-16
0220	585781MA	1	BOLT, Carriage, 3/8-16 x 1-1/4, G5
0230	1739574YP	1	IDLER, Auger
0240	1739964YP	1	SPACER, Auger Bracket
0250	1960027SM	1	WASHER, 1/2
0260	1733451SM	1	ARM, Control
0270	0031X6MA	1	PIN, Hair
0280	1736381YP	1	PIN, Clevis
0290	1737221AYP	1	PANEL, Bottom
0300	1927429SM	6	SCREW, Hex Washer Head, Taptite, 1/4-20 x 5/8
0310	165X159MA	1	SPRING, Extension, Auger, 5
0320	1739107BIYP	1	FRAME BOX
0325	1739093AYP	1	BRACKET, Auger and Traction Rod Mount
0330	1754138BIYP	1	PLATE, Engine (Use on 11.5TP Models)
0330	1754136BIYP	1	PLATE, Engine (Use on 14.5TP Models)
0350	1664847SM	15	CAPSCREW, Hex Washer Head, Taptite, 5/16-18 x 3/4

Footnotes

Note* To verify your specific engine model, please reference the ID Tag located on your engine. See your local Briggs & Stratton distributor for parts and service.

The above parts group applies to the following Mfg. Nos.:

1696062-01 - MM741450E

Engine Group

NOTE: Unless noted otherwise, use the standard hardware torque specification chart.

2989770

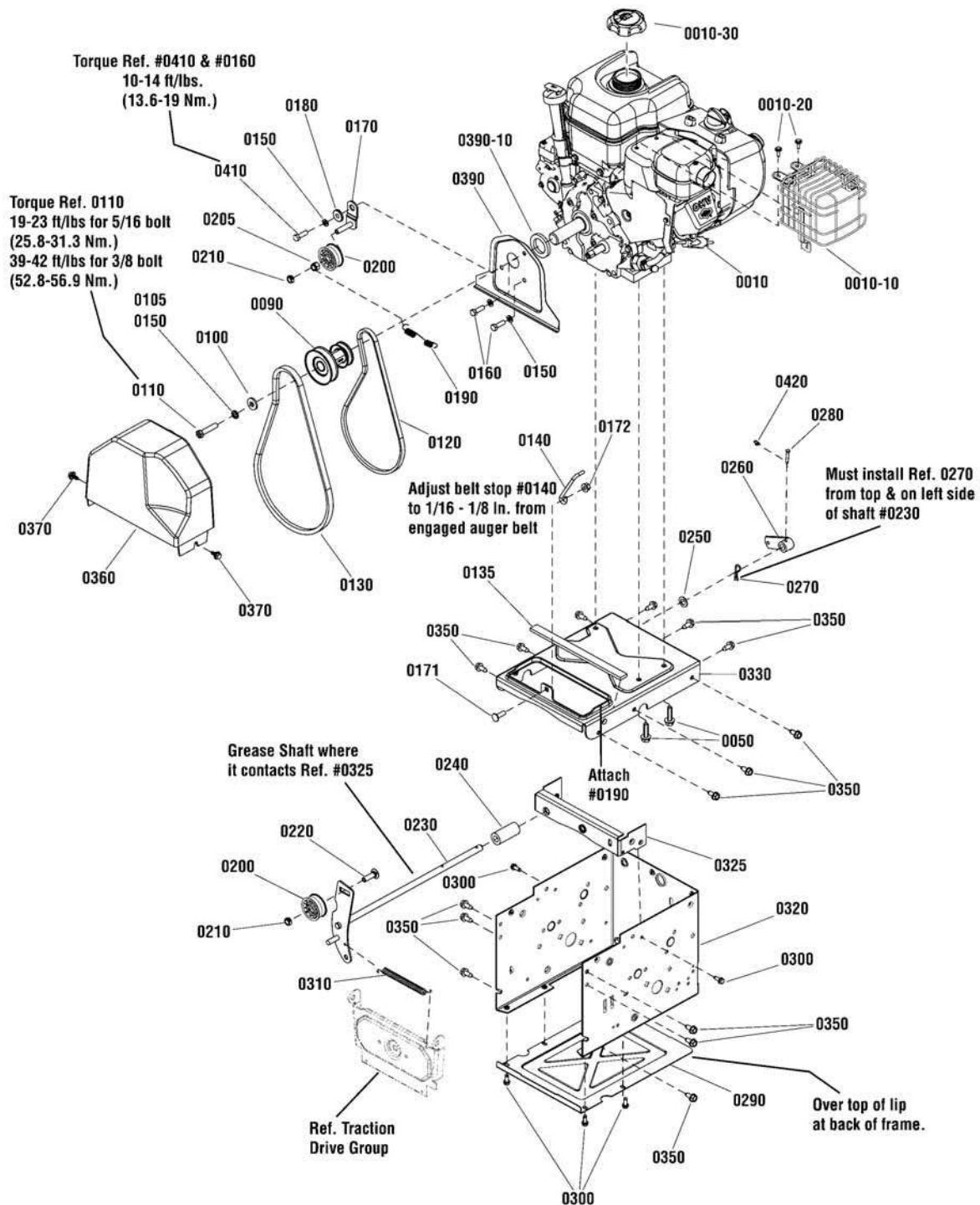

The above parts group applies to the following Mfg. Nos.:

1696062-01 - MM741450E

Engine Group

REF NO	PART NO.	QTY.	DESCRIPTION
0360	1750551YP	1	COVER, Belt
0370	26X306MA	2	SCREW, Hex Washer Head, 1/4 x 3/4
0390	1733868ASM	1	WATER SHIELD
0390-10	1733898SM	1	SEAL, Foam
0410	910828MA	1	BOLT, Hex, 5/16-24 x 1
0420	7023590SM	1	COTTER PIN, 1/4

Not for
Reproduction

Footnotes

Note* To verify your specific engine model, please reference the ID Tag located on your engine. See your local Briggs & Stratton distributor for parts and service.

The above parts group applies to the following Mfg. Nos.:

1696062-01 - MM741450E

Auger Drive Group

NOTE: Unless noted otherwise,
use the standard hardware torque
specification chart.

2989780

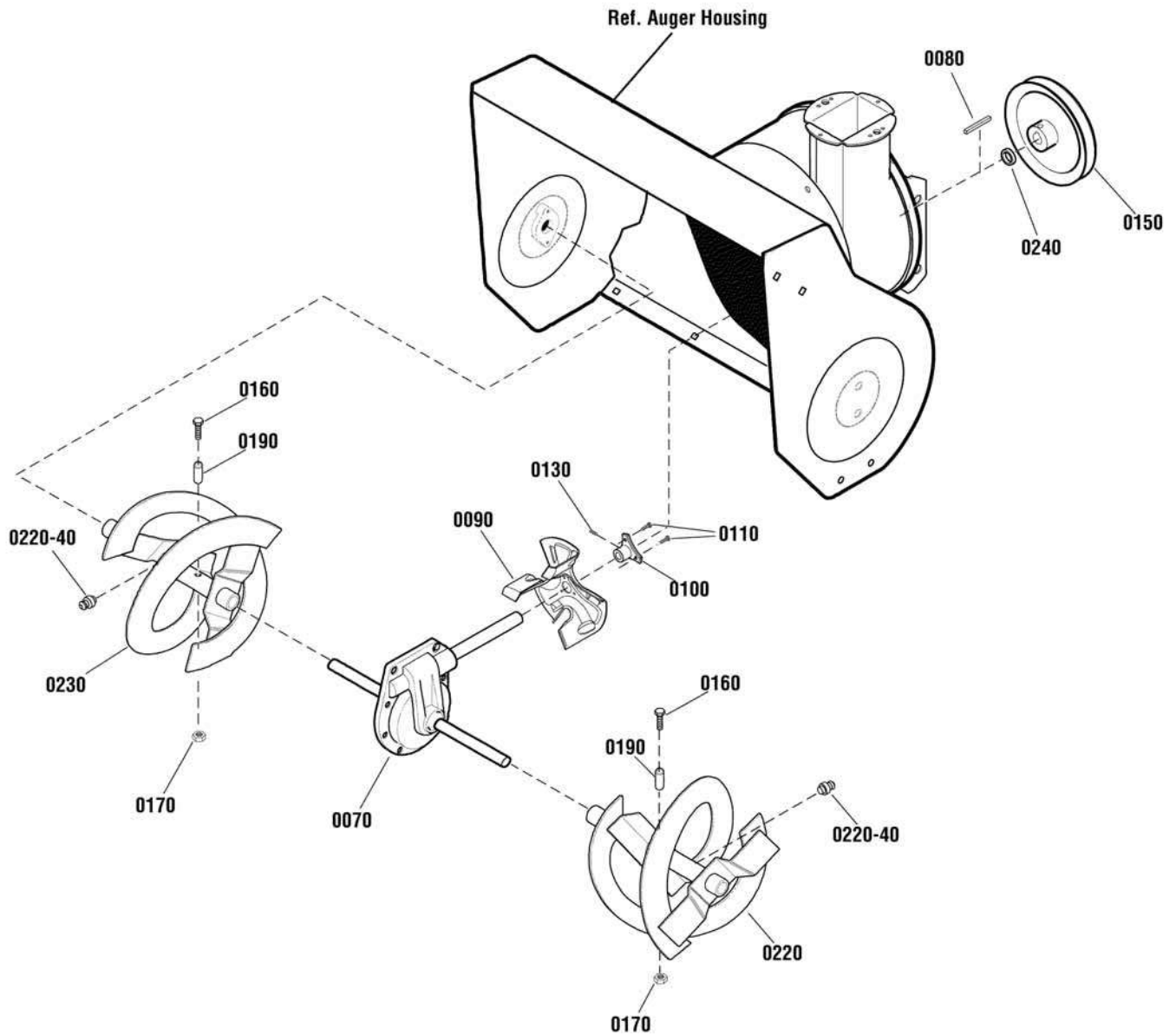

The above parts group applies to the following Mfg. Nos.:

1696062-01 - MM741450E

1696200-00 - MM691150E

Auger Drive Group

REF NO	PART NO.	QTY.	DESCRIPTION
0070	1752897YP	1	GEAR CASE ASSEMBLY, 27"
0070	1752898YP	1	GEAR CASE ASSEMBLY, 29"
0080	2001022MA	1	KEY, Square, 3/16 x 3/4
0090	1739094AYP	1	IMPELLER
0100	1739073YP	1	HUB, Impeller
0110	1930601SM	3	SCREW, Hex Washer Head, Taptite, 5/16-18 x 5/8
0130	7090848SM	3	SET SCREW, Socket Head, 5/16-18 x 1/2
0150	583146MA	1	PULLEY, 8.4 V4L .67 ID (Used on 27" Models)
0150	1501211MA	1	PULLEY, 8.4 V4L .67 ID, Hybrid (Used on 29" Models)
0160	9524MA	2	CAPSCREW, Hex Head, 1/4-20 x 1-3/4
0170	73826MA	2	NUT, Hex Center Lock, 1/4-20
0190	3943MA	2	SPACER, Sleeve, 1/4 x 1/2"
0220	1740736BJYP	1	AUGER, LH, 27" (Includes Ref. No. 0220-40)
0220	1740738BJYP	1	AUGER, LH, 29" (Includes Ref. No. 0220-40)
0230	1740737BJYP	1	AUGER, RH, 27" (Includes Ref. No. 0220-40)
0230	1740739BJYP	1	AUGER, RH, 29" (Includes Ref. No. 0220-40)
0220-40	10104MA	2	FITTING, Grease
0240	1501158MA	1	SPACER, Pulley
--	1501216MA	1	KIT, Shear Bolt (Includes Ref. Nos. 0160, 0170 & 0190)

Not for
Reproduction

Footnotes

The above parts group applies to the following Mfg. Nos.:

1696062-01 - MM741450E

1696200-00 - MM691150E

Auger Housing Group

2990612_0740

NOTE: Unless noted otherwise,
use the standard hardware torque
specification chart.

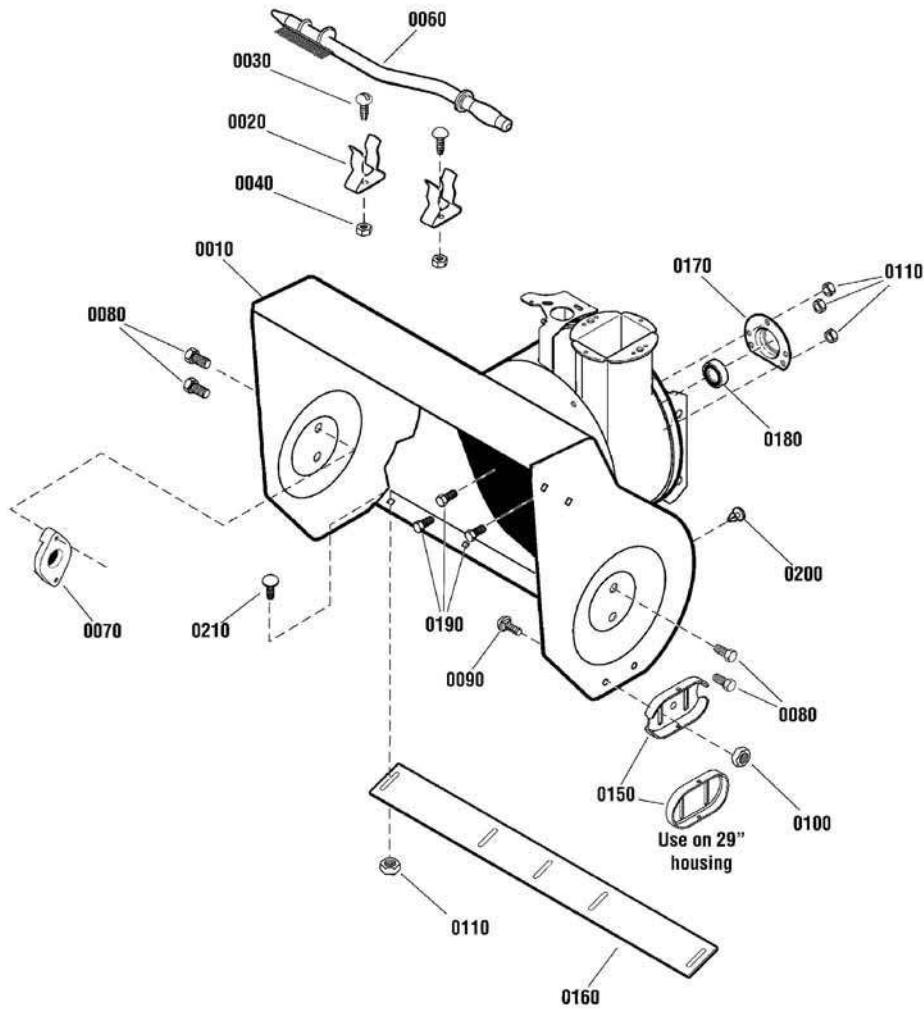

The above parts group applies to the following Mfg. Nos.:

1696200-00 - MM691150E

Auger Housing Group

REF NO	PART NO.	QTY.	DESCRIPTION
0010	1687531YP	1	HOUSING, Auger, 27"
0010	1687546YP	1	HOUSING, Auger, 29"
0020	1736620YP	2	CLIP, Retainer
0030	1960569SM	2	SCREW, Truss Head, Torx #10-24 x 3/8
0040	7091290SM	2	NUT, Hex Lock, Nylon, #10C
0060	1736094YP	1	BRUSH, Cleanout
0070	53757MA	2	BEARING, Auger
0080	25X021MA	6	SCREW, Hex Head Cap, 5/16-18 x 3/4
0090	7091790YP	4	BOLT, Carriage, 3/8-16 x 1-1/4, G5
0100	7091619SM	4	NUT, Hex Flange, 3/8-16
0110	1931277SM	7	NUT, Hex Flange, Whiz Lock, 5/16-18
0150	1727854BMYP	2	SKID, Height Adjust, Reversible (Used on 27" Models)
0150	1750222YP	2	SKID, Height Adjust, Reversible, Polymer (Used on 29" Models)
0160	1740745AYP	1	BLADE, Scraper, 27
0160	1740746AYP	1	BLADE, Scraper, 29
0170	582957YZMA	1	RETAINER, Ball Bearing
0180	1705897SM	1	BEARING, Ball
0190	001X45MA	3	BOLT, Hex, 5/16-18 x 5/8
0200	760040MA	2	PLUG, Panel
0210	7090799SM	4	BOLT, Carriage, 5/16-1/ x 5/8, G5

Not for
Reproduction

Footnotes

The above parts group applies to the following Mfg. Nos.:

1696200-00 - MM691150E

Traction Drive Group - Standard

NOTE: Unless noted otherwise,
use the standard hardware torque
specification chart.

2989173

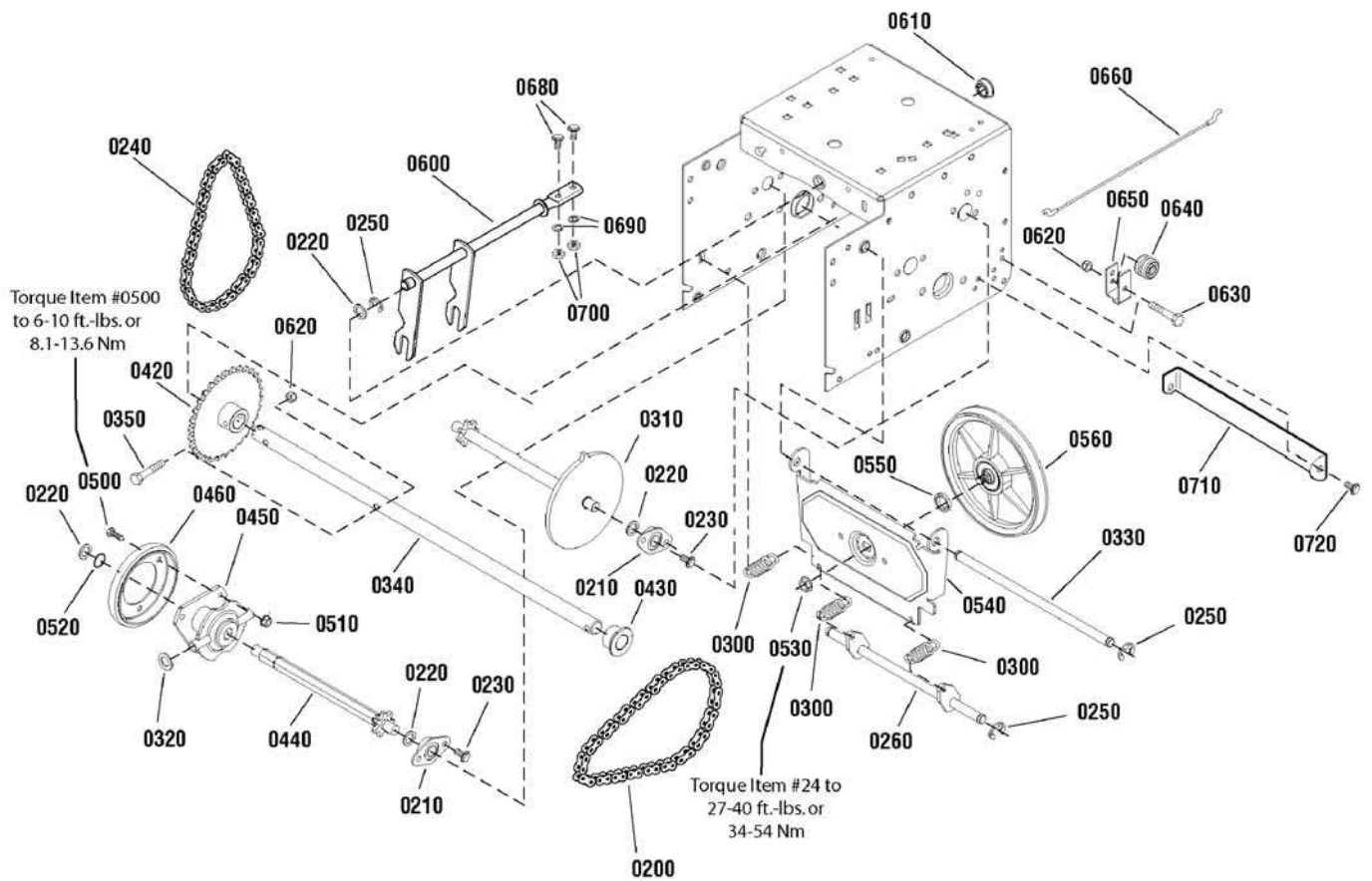

The above parts group applies to the following Mfg. Nos.:

1696062-01 - MM741450E

1696200-00 - MM691150E

Traction Drive Group - Standard

REF NO	PART NO.	QTY.	DESCRIPTION
0200	579851MA	1	CHAIN, Roller, #420 x 19.00
0210	334163MA	4	BEARING AND RETAINER ASSEMBLY
0220	579858MA	5	WASHER, Flat, 1/2
0230	1924856SM	8	SCREW, Hex Washer Head Taptite, 5/16-18 x 1/2
0240	579868MA	1	CHAIN, Roller, #420 x 18.00
0250	11X30MA	5	RETAINER, Ring, 7/16
0260	1502105YZMA	1	SPRING LINK ASSEMBLY
0300	1736469YP	3	SPRING, Extension
0310	1501090MA	1	SPROCKET, Set
0320	1960027SM	2	WASHER, 1/2
0330	1501092YZMA	1	AXLE, Swing Plate
0340	1501563YZMA	1	AXLE, 16"
0350	01X193MA	1	SCREW, 1/4 - 20 x 1-3/4
0420	1501089MA	1	SPROCKET, Axle
0430	1501114MA	2	BEARING, Axle
0440	1501100MA	1	HEX SHAFT & SPROCKET ASSEMBLY
0450	1739282YP	1	HUB, Friction Wheel & Bearing
0460	1501435MA	1	WHEEL, Friction Disc
0500	1921959SM	3	CAPSCREW, Hex Head 1/4-20 x 5/8 G5
0510	1928372SM	3	NUT, Hex KEPS 1/4-20
0520	1733326SM	1	RING, Retaining Extension
0530	15X114MA	1	NUT, Flange Lock, 3/8-24
0540	1501057YZMA	1	PLATE, Swinging
0550	1501158MA	1	SPACER, Friction Pulley
0560	1501115MA	1	FRICTION PULLEY ASSEMBLY
0600	1501110YZMA	1	ASSEMBLY, Speed Selector
0610	579944MA	1	BEARING, Flange
0620	1920397SM	2	NUT, Hex Lock ESNA Light 1/4-20
0630	1922837SM	1	CAPSCREW, Hex Head, 1/4-20 x 1-1/2 G5
0640	579860MA	1	SPOOL CABLE, Auger Control
0650	1750398YP	1	BRACKET, Cable Spool
0660	1750403YP	1	CABLE, Front Drive
0680	001X38MA	2	BOLT, Hex, 1/4-20 x 5/8
0690	1916964SM	2	LOCKWASHER, Spring, 1/4-20
0700	7091576SM	2	NUT, Hex, 1/4-20, G5
0710	1502030YZMA	1	BRACKET, Support
0720	1927429SM	2	CAPSCREW, Hex Washer Head, Taptite, 1/4-20 x 5/8

Footnotes

The above parts group applies to the following Mfg. Nos.:

1696062-01 - MM741450E

1696200-00 - MM691150E

Wheels & Tires Group

2989661

NOTE: Unless noted otherwise,
use the standard hardware torque
specification chart.

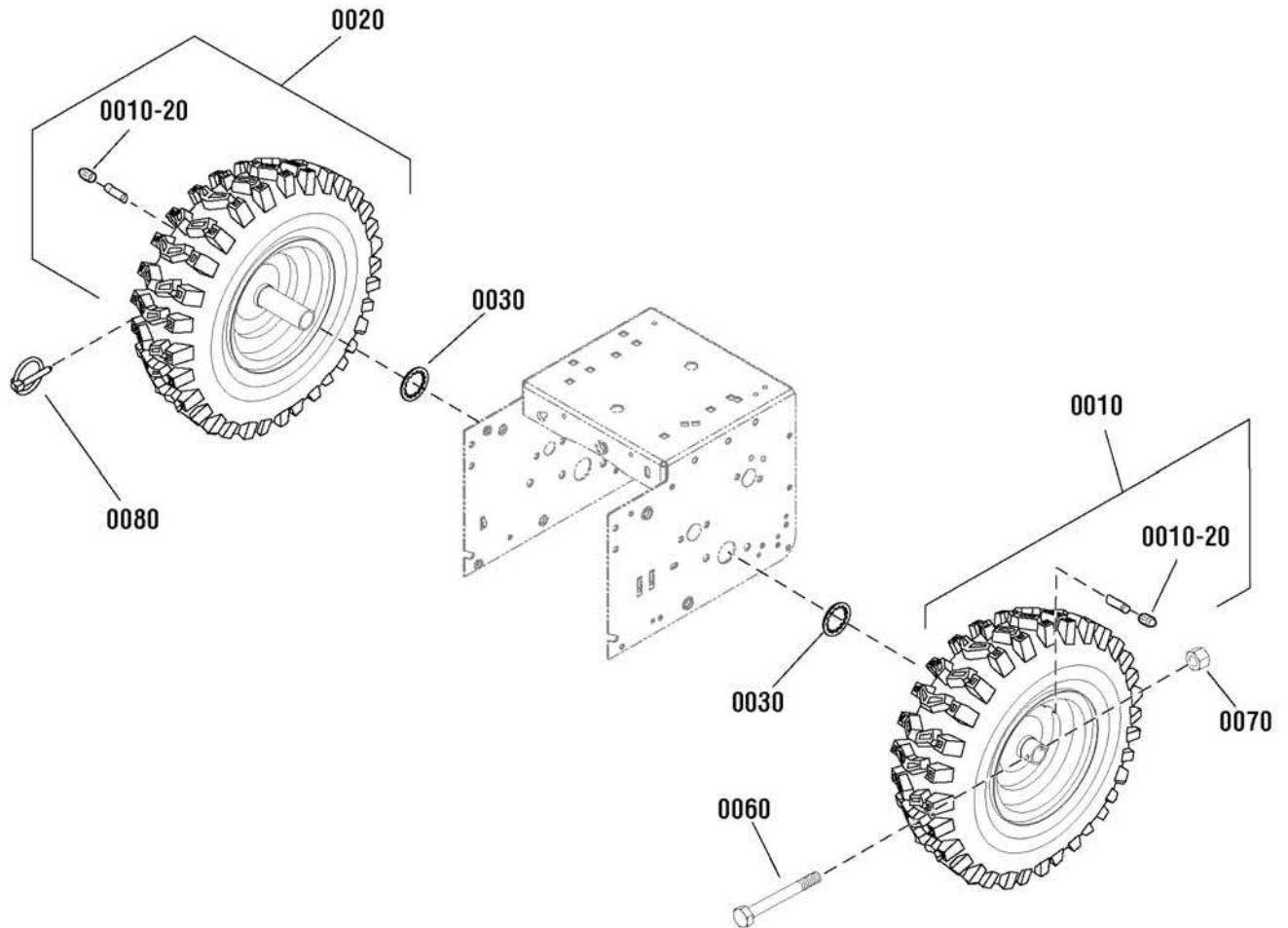

The above parts group applies to the following Mfg. Nos.:

1696062-01 - MM741450E

1696200-00 - MM691150E

Wheels & Tires Group

REF NO	PART NO.	QTY.	DESCRIPTION
0010	1754486YP	1	WHEEL & TIRE ASSEMBLY, 15 x 5, P2-407, LH (Use on 27" Model)
0010	1754243YP	1	WHEEL & TIRE ASSEMBLY, 4.80-8, P2-578, LH (Use on 29" Model)
0020	1754487YP	1	WHEEL & TIRE ASSEMBLY, 15 x 5, P2-407, RH (Use on 27" Model)
0020	1754245YP	1	WHEEL & TIRE ASSEMBLY, 4.80-8, P2-578, RH (Use on 29" Model)
0010-20	2172353SM	1	VALVE STEM & CAP (Included with Ref. Nos. 0010 & 0020)
0030	1657528SM	2	RING, Retaining, Self Lock, 3/4
0060	577015MA	1	BOLT, Hex, 1/4-20 x 1-3/4, G5
0070	15X145MA	1	NUT, Hex, Nylock, 1/4-20
0080	73842MA	1	PIN, Klik, 1/4 x 1-3/8

Not for
Reproduction

Footnotes

The above parts group applies to the following Mfg. Nos.:

1696062-01 - MM741450E

1696200-00 - MM691150E

NOTE: Unless noted otherwise,
use the standard hardware torque
specification chart.

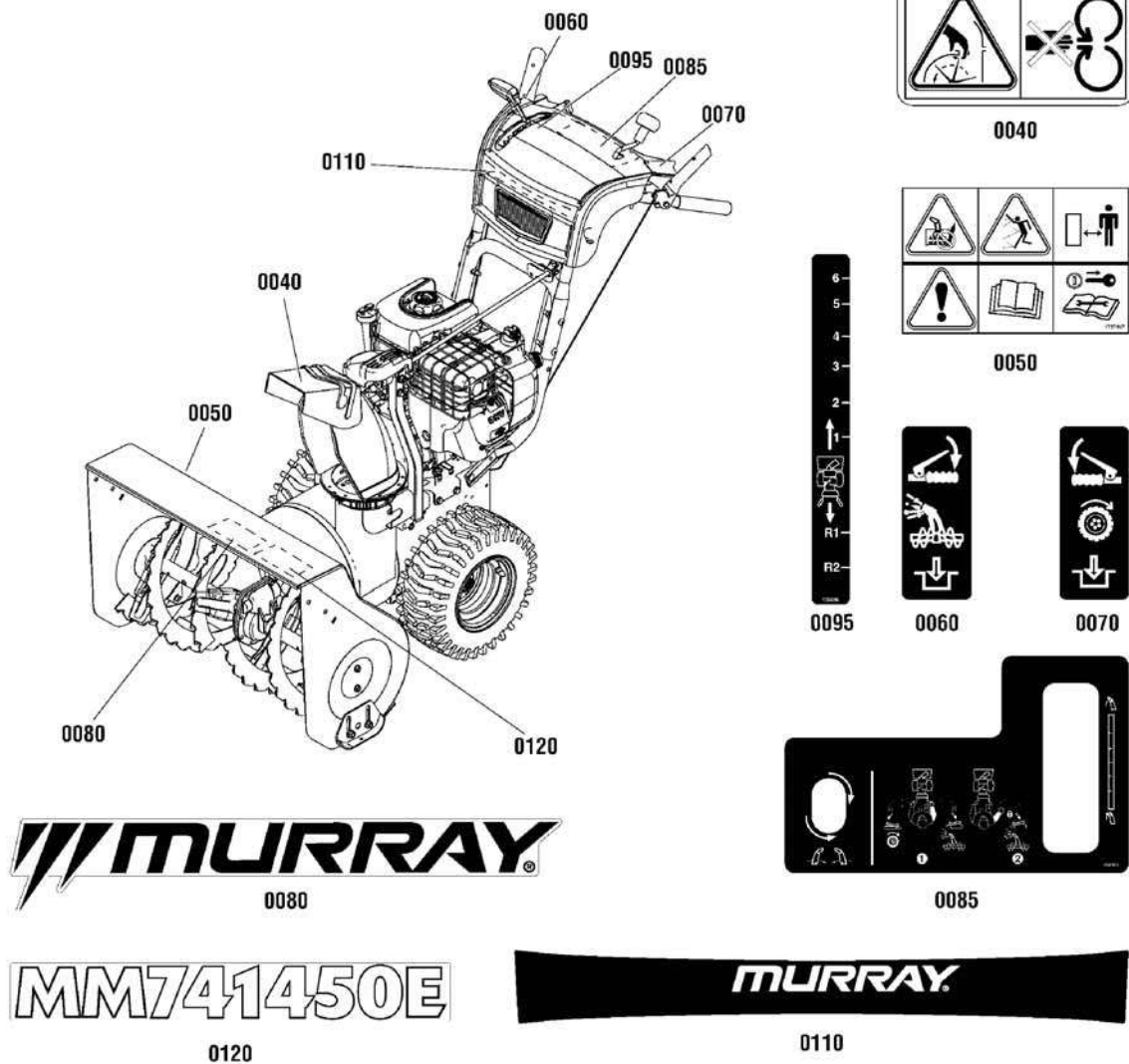

The above parts group applies to the following Mfg. Nos.:

- 1696062-01 - MM741450E
- 1696200-00 - MM691150E

Decals Group 2990614_2990694)

REF NO	PART NO.	QTY.	DESCRIPTION
0040	1727207SM	1	DECAL, Chute Warning
0050	1737867YP	1	DECAL, Danger Auger Icons
0060	1753133YP	1	DECAL, Auger Control Symbols
0070	1753134YP	1	DECAL, Traction Control Symbols
0080	1738309YP	1	DECAL, Logo
0085	1737874YP	1	DECAL, Instruction
0095	1736616YP	1	DECAL, Gear Shift
0110	1736891YP	1	DECAL, Logo, Dash
0120	1754777YP	1	DECAL, Model MM691150E (Not Illustrated)
0120	1754779YP	1	DECAL, Model MM741450E

Not for
Reproduction

Footnotes

The above parts group applies to the following Mfg. Nos.:

1696062-01 - MM741450E
1696200-00 - MM691150E

Gear Case Assembly

NOTE: Unless noted otherwise,
use the standard hardware torque
specification chart.

1752897

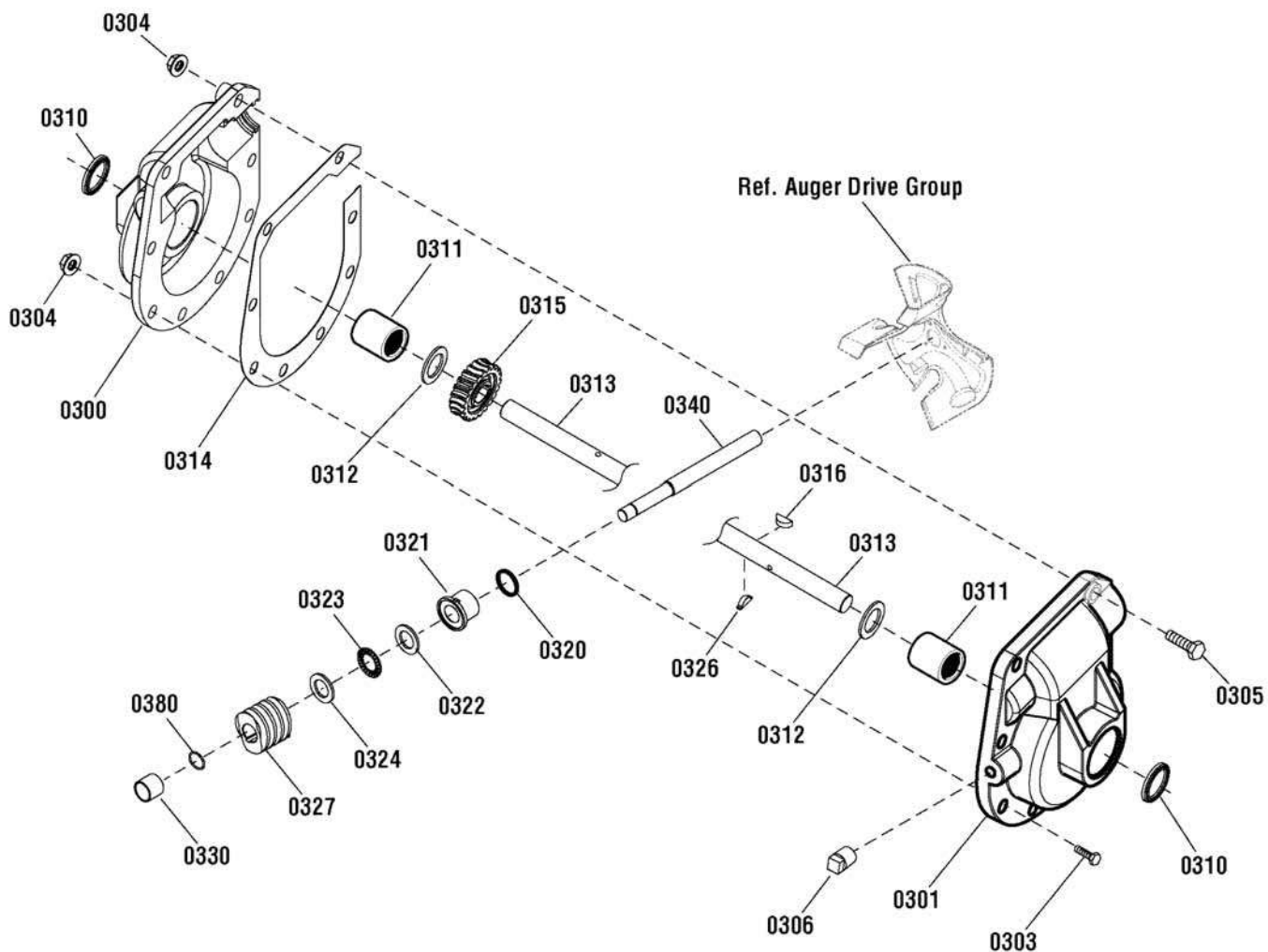

The above parts group applies to the following Mfg. Nos.:

1696062-01 - MM741450E

1696200-00 - MM691150E

Gear Case Assembly

REF NO	PART NO.	QTY.	DESCRIPTION
0300	896MA	1	CASE, Gear, RH
0301	895MA	1	CASE, Gear, LH
0303	910828MA	7	BOLT, Hex, 5/16-24 x 1
0304	71100MA	8	NUT, Hex Flange, Serrated Lock, 5/16-24
0305	330434MA	1	CAPSCREW, Hex Head, 5/16-24
0306	53749MA	1	PLUG, Pipe
0310	780151MA	2	SEAL, Oil
0311	53743MA	2	BEARING, Sleeve, 1 x 1-1/4 x 1
0312	53748MA	2	WASHER, Flat, 1-1-1/2
0313	760529MA	1	SHAFT, Auger Out, 27"
0313	760528MA	1	SHAFT, Auger Out, 29"
0314	897MA	1	GASKET
0315	1752500YP	1	GEAR, Worm, 22T
0316	73905MA	1	KEY, Woodruff
0320	53737MA	1	RING, Quad
0321	583126MA	1	BEARING, Flange, 3/4 ID x 1-1/8 OD
0322	48275MA	1	WASHER, Thrust
0323	50684MA	1	BEARING, Roll Thrust, 3/4 ID x 1-1/4 OD
0324	48275MA	1	WASHER, Thrust
0326	50795MA	1	KEY, HI-PRO
0327	53732MA	1	WORMGEAR, 1-3/4 OD x 1-1/2"
0330	53731MA	1	BEARING, Sleeve, 3/4 ID x 7/8 OD
0340	1751535YP	1	SHAFT, Impeller
0380	1752515YP	1	RING, Retaining, 3/4

Not for
Reproduction

Footnotes

The above parts group applies to the following Mfg. Nos.:

1696062-01 - MM741450E

1696200-00 - MM691150E

Discharge Chute

NOTE: Unless noted otherwise,
use the standard hardware torque
specification chart.

2990692

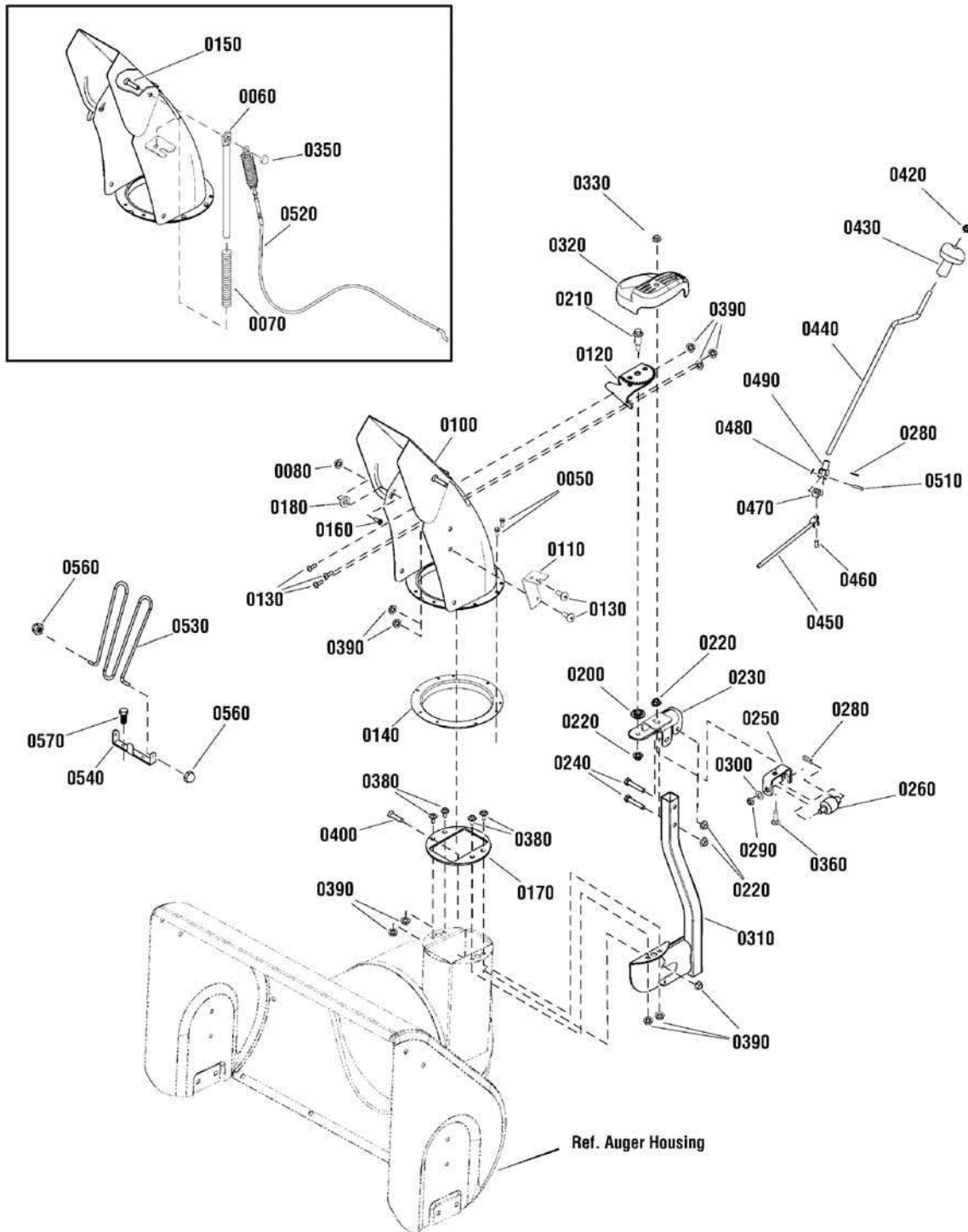

The above parts group applies to the following Mfg. Nos.:

1696062-01 - MM741450E

1696200-00 - MM691150E

Discharge Chute

REF NO	PART NO.	QTY.	DESCRIPTION
0050	0025X2MA	4	SCREW, Hex Head, Taptite, 1/4-20 x 1/2
0060	1734708ASM	1	ROD, Spring
0070	1734647SM	1	SPRING, Compression
0080	1739305YP	1	NUT, Hex Flange ESNA, 5/16-18
0100	1736312YP	1	DISCHARGE CHUTE ASSEMBLY
0110	1736378AYP	1	BRACKET, Cable Deflector
0120	1736038YP	1	GEAR & SUPPORT ASSEMBLY, Chute
0130	1960715SM	5	SCREW, Truss Head, 1/4-20 x 3/4
0140	1736444AYP	1	RING, Chute Base
0150	1960767YP	1	SCREW, Allen, Button Head, 5/16-18 X 1-1/4
0160	1931335SM	1	BOLT, Carriage, 5/16-18 x 1, G5
0170	1735767YP	1	GUIDE, Chute Ring
0180	2860210SM	2	WASHER, Nylon, 3/8
0200	1733026SM	1	WASHER
0210	1732412SM	1	BOLT, Shoulder 5/16-18, G5
0220	1960684SM	4	NUT, Hex KEPS, Conical Washer, 5/16-18
0230	1734423ASM	1	SUPPORT, Gear & Chute
0240	1922127SM	2	CAPSCREW, Hex Head 5/16-18 x 1-3/4 G5
0250	1738020YP	1	SUPPORT, Worm "U"
0260	1734439SM	1	WORM, Chute L.H.
0280	1501293MA	2	PIN, Hair Chute Gear
0290	1960762SM	1	NUT, Hex Lock Jam ESNA Lite 3/8-24
0300	1734542SM	1	WASHER, Cup
0310	1736195AYP	1	CHUTE SUPPORT ASSEMBLY
0320	1734442SM	1	COVER, Gear
0330	1935048SM	1	NUT, Hex Flange 5/16-18 Two Way Lock
0350	1928698SM	1	NUT, Hex Toplock Jam, 5/16-18
0360	1931335SM	1	BOLT, Carriage, 5/16-18 x 1 G5
0380	691005	4	CAPSCREW, Hex-Flange, 1/4-20 x 5/8
0390	5025391SM	10	NUT, Hex Flange, Nylock, 1/4-20
0400	02X101MA	1	BOLT, Carriage, 1/4-20 x 3/4
0420	1960093SM	1	NUT, Push Pal 5/16 Diameter Stud Capped
0430	1714084SM	1	KNOB, SPINNER
0440	1751224YP	1	CRANK ROD
0450	1735660YP	1	CHUTE, Crank
0460	578060MA	1	PIN, Universal Joint
0470	578063MA	1	BLOCK, Pivot
0480	579493MA	1	PIN, Cotter
0490	1733611SM	1	YOKE ADAPTER ASSEMBLY
0510	578309MA	1	PIN, CLEVIS
0520	1750623YP	1	CABLE & SPRING ASSEMBLY
0530	1733475SM	1	GUARD, Chute
0540	1752883YP	1	BRACKET, Chute Guard

Footnotes

The above parts group applies to the following Mfg. Nos.:

1696062-01 - MM741450E

1696200-00 - MM691150E

Discharge Chute

NOTE: Unless noted otherwise,
use the standard hardware torque
specification chart.

2990692

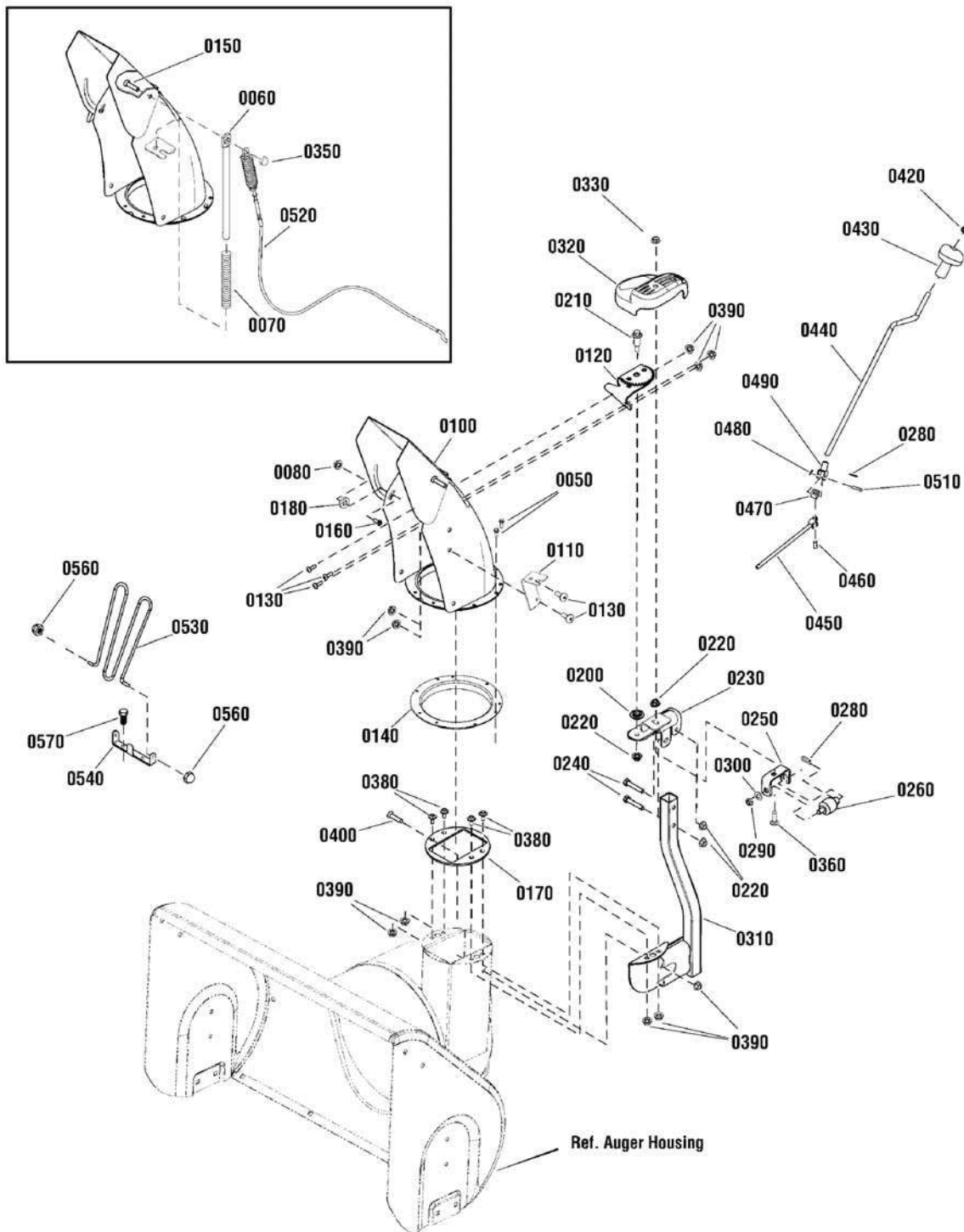

The above parts group applies to the following Mfg. Nos.:

1696062-01 - MM741450E

1696200-00 - MM691150E

Discharge Chute

REF NO	PART NO.	QTY.	DESCRIPTION
0560	1960140SM	1	NUT, Push, 3/16
0570	0025X2MA	1	SCREW, Hex Head, Taptite, 1/4-20 x 1/2

Not for
Reproduction

Footnotes

The above parts group applies to the following Mfg. Nos.:

1696062-01 - MM741450E

1696200-00 - MM691150E

Not for
Reproduction

Not for
Reproduction

Not for
Reproduction

Hardware Identification & Torque Specifications

Torque Specification Chart								
FOR STANDARD METRIC MACHINE HARDWARE (Tolerance ± 20%)								
Property Class	5.6		8.8		10.9		12.9	
	Class 5.6		Class 8.8		Class 10.9		Class 12.9	
Size Of Hardware	in/lbs		in/lbs		in/lbs		in/lbs	
	ft/lbs	Nm.	ft/lbs	Nm.	ft/lbs	Nm.	ft/lbs	Nm.
M3	5.88	.56	13.44	1.28	19.2	1.80	22.92	2.15
M4	13.44	1.28	30.72	2.90	43.44	4.10	52.56	4.95
M5	26.4	2.50	60.96	5.75	5.97	8.10	7.15	9.7
M6	44.64	4.3	7.3	9.9	10.3	14	12.1	16.5
M7	5.2	7.1	12.1	16.5	16.9	23	19.9	27
M8	7.7	10.5	17.7	24	25	34	29	40
M10	15	21	35	48	50	67	59	81
M12	26	36	61	83	86.2	117	103	140
M14	42	58	101	132	136	185	162	220
M16	64	88	147	200	210	285	250	340
M18	89	121	202	275	287	390	346	470
M20	126	171	290	390	405	550	486	660
M22	169	230	390	530	559	745	656	890
M24	217	295	497	375	708	960	840	1140
M27	320	435	733	995	1032	1400	1239	1680
M30	435	590	995	1350	1401	1900	1681	2280
M33	590	800	1349	1830	1902	2580	2278	3090
M36	759	1030	1740	2360	2441	3310	2935	3980
M39	988	1340	2249	3050	3163	4290	3798	5150

The guides and ruler furnished below are designed to help you select the appropriate hardware.



Nut, M8

Thread Diameter (mm)
Inside Diameter (in)
Threads per inch

Nut, 1/2-16

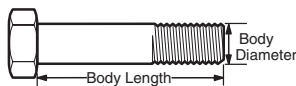

Screw, M8- 1.25 x 25

Thread Diameter (mm)
Body Diameter
Distance between threads (mm)
Threads per inch
Body Length (mm)
Body Length (in)

Screw, 1/2- 16 x 2

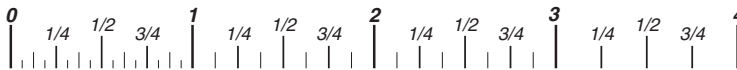

Standard Hardware Sizing

When a washer or nut is identified as **1/2"** (M8), this is the *Nominal size*, meaning the *inside diameter* is 1/2 inch (8mm metric thread diameter); if a second number is present it represents the *threads per inch* (distance between threads).

When bolt or capscrew is identified as **1/2 - 16 x 2"** (M8 - 1.25 x 50), this means the *Nominal size*, or body diameter is 1/2 inch (8mm metric thread diameter), the second number, 16, represents the *threads per inch*, (*1.25 thread diameter*). The final number is the body length of the bolt or screw, 2 inches (50mm).

Torque Specification Chart						
FOR STANDARD MACHINE HARDWARE (Tolerance ± 20%)						
Hardware Grade	No Marks		SAE Grade 5		SAE Grade 8	
	SAE Grade 2		SAE Grade 5		SAE Grade 8	
Size Of Hardware	in/lbs		in/lbs		in/lbs	
	ft/lbs	Nm.	ft/lbs	Nm.	ft/lbs	Nm.
8-32	19	2.1	30	3.4	41	4.6
8-36	20	2.3	31	3.5	43	4.9
10-24	27	3.1	43	4.9	60	6.8
10-32	31	3.5	49	5.5	68	7.7
1/4-20	66	7.6	8	10.9	12	16.3
1/4-28	76	8.6	10	13.6	14	19.0
5/16-18	11	15.0	17	23.1	25	34.0
5/16-24	12	16.3	19	25.8	29	34.0
3/8-16	20	27.2	30	40.8	45	61.2
3/8-24	23	31.3	35	47.6	50	68.0
7/16-14	30	40.8	50	68.0	70	95.2
7/16-20	35	47.6	55	74.8	80	108.8
1/2-13	50	68.0	75	102.0	110	149.6
1/2-20	55	74.8	90	122.4	120	163.2
9/16-12	65	88.4	110	149.6	150	204.0
9/16-18	75	102.0	120	163.2	170	231.2
5/8-11	90	122.4	150	204.0	220	299.2
5/8-18	100	136	180	244.8	240	326.4
3/4-10	160	217.6	260	353.6	386	525.0
3/4-16	180	244.8	300	408.0	420	571.2
7/8-9	140	190.4	400	544.0	600	816.0
7/8-14	155	210.8	440	598.4	660	897.6
1-8	220	299.2	580	788.8	900	1,244.0
1-12	240	326.4	640	870.4	1,000	1,360.0

NOTES

- These torque values are to be used for all hardware excluding: locknuts, self-tapping screws, thread forming screws, sheet metal screws and socket head setscrews.
- Recommended seating torque values for locknuts:
 - for prevailing torque locknuts - use 65% of grade 5 torques.
 - for flange whizlock nuts and screws - use 135% of grade 5 torques.
- Unless otherwise noted on assembly drawings, all torque values must meet this specification.

Common Hardware Types

Hex Head Capscrew

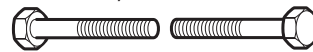

Washer



Lockwasher

Carriage Bolt



Hex Nut

Wrench & Fastener Size Guide

1/4" Bolt or Nut Wrench—7/16"	5/16" Bolt or Nut Wrench—1/2"	3/8" Bolt or Nut Wrench—9/16"	7/16" Bolt or Nut Wrench (Bolt)—5/8" Wrench (Nut)—11/16"	1/2" Bolt or Nut Wrench—3/4"
M6 Bolt or Nut Wrench—10mm	M8 Bolt or Nut Wrench—13mm	M10 Bolt or Nut Wrench—17mm	M12 Bolt or Nut Wrench—19mm	M14 Bolt or Nut Wrench—22mm

Not for
Reproduction

**IT IS THE POLICY OF BRIGGS & STRATTON CORP. TO IMPROVE ITS PRODUCTS
WHENEVER IT IS POSSIBLE AND PRACTICAL TO DO SO. WE RESERVE THE RIGHT TO
MAKE CHANGES OR ADD IMPROVEMENTS AT ANY TIME WITHOUT INCURRING ANY
OBLIGATION TO MAKE SUCH CHANGES ON PRODUCTS.**

Briggs & Stratton Power Products Group

12301 W. Wirth Street
Wauwatosa, WI, 53222 USA

www.murray.com

© Copyright 2012 by Briggs & Stratton Corporation
Milwaukee, WI, USA. All rights reserved