

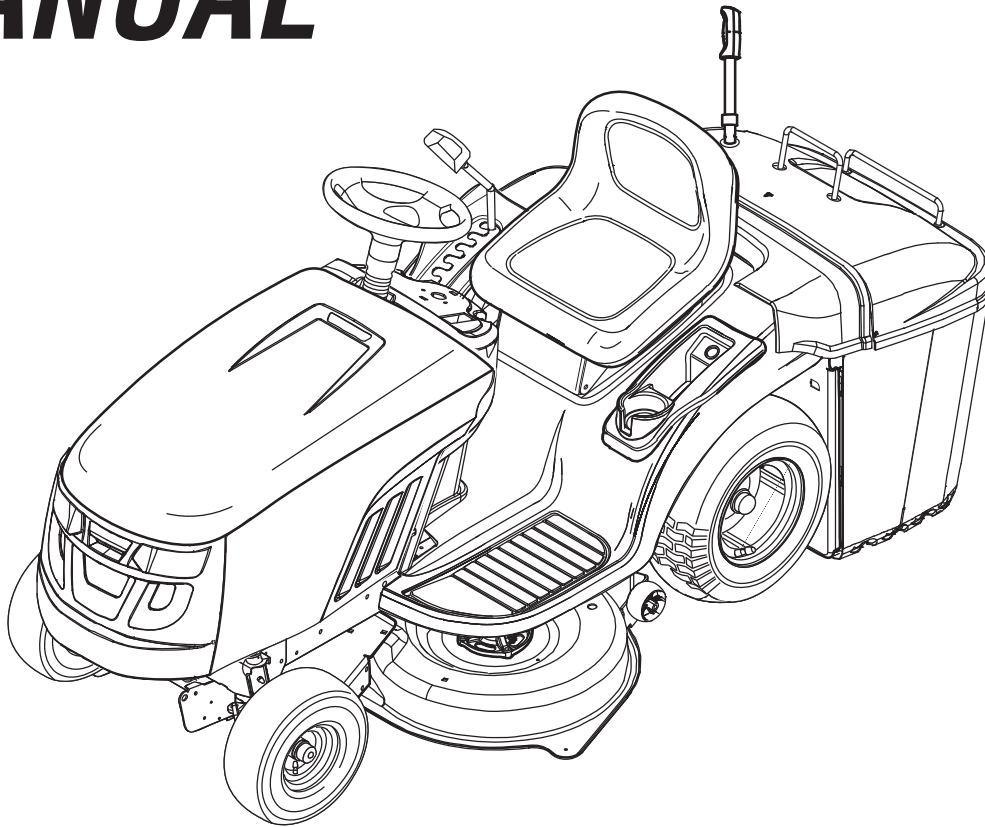

# PARTS MANUAL



## 17.5HP Models

Mfg. No.	Description
1696109-00	EMT17538RDF, 17.5HP 96cm Murray Rear Discharge Lawn Tractor (2012)

## 18HP Models

Mfg. No.	Description
1696110-00	EMT18v38RDF, 18HP 96cm Murray Rear Discharge Lawn Tractor (2012)

Manual Part No. 1754222

Revision -

Rev. Date: 1/25/2012

Not for  
Reproduction

<b>PRODUCT COMPONENTS</b>	<b>PAGES</b>
Frame & Front Axle Group .....	4
Steering Group .....	8
Engine Group - 17.5HP & 18HP .....	10
Transmission Group .....	12
Transmission SERVICE PARTS - Hydro Gear 324-0610 .....	14
Controls Group .....	20
Electrical Group .....	22
Hood, Grille & Dash Group .....	24
Seat Deck & Fuel Tank Group .....	26
Lift Group .....	28
Wheel & Tires Group .....	30
Decal Group .....	32
Guard Group - 38" RD .....	34
Collector Group .....	36
38" Mower Deck - Support Group .....	40
38" Mower Deck - Clutch Group .....	42
38" Mower Deck - Housing, Arbors & Blade Group .....	44
<b>Torque Specification Chart .....</b>	<b>Inside Back Cover</b>

Not for  
Reproduction

## Frame & Front Axle Group

885707

NOTE: Unless noted otherwise,  
use the standard hardware torque  
specification chart.

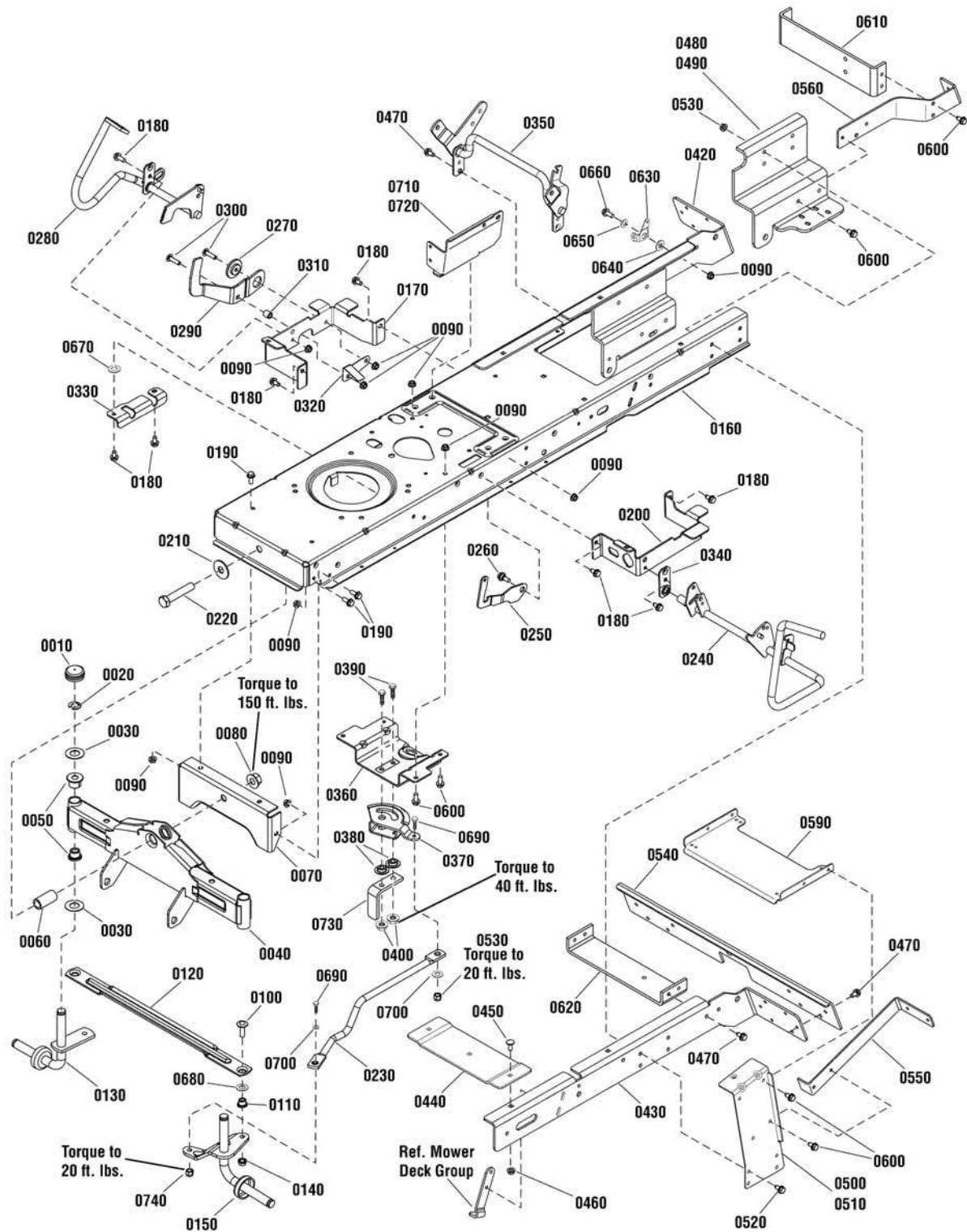

The above parts group applies to the following Mfg. Nos.:

1696109-00 - EMT17538RDF

1696110-00 - EMT18v38RDF

## Frame & Front Axle Group

REF NO	PART NO.	QTY.	DESCRIPTION
0010	094618MA	2	CAP, Hub
0020	0011X3MA	2	E-RING, 3/4
0030	17X195MA	4	WASHER, Flat
0040	885693YP	1	AXLE, Front
0050	2176440SM	4	BUSHING
0060	1738193YP	1	SPACER
0070	1727902SM	1	PLATE, Axle Support
0080	2860646SM	1	NUT, Hex Flange Two-Way Lock, 5/8-11
0090	1931277SM	16	NUT, Hex Flange, Whiz Lock, 5/16-18
0100	1960032SM	2	CAPSCREW, Hex Head, 3/8-16 x 1-1/4, .141 Thread G5
0110	1611705SM	2	SPACER
0120	1751964YP	1	ROD, Tie
0130	1727872ASM	1	SPINDLE & CUP ASSEMBLY, R.H.
0140	1930645SM	2	NUT, Hex, Flange, Locking, 3/8-16
0150	1751922YP	1	SPINDLE & ARM ASSEMBLY, L.H.
0160	885656BMYP	1	FRAME
0170	1727904SM	1	SUPPORT, Front Footrest R.H.
0180	1930601SM	8	SCREW, Taptite, 5/16-18 x 5/8
0190	1930591SM	6	CAPSCREW, Hex Head, Flange Whiz Lock, 5/16-18 x 3/4
0200	885536AYP	1	SUPPORT, Front Footrest L.H.
0210	1960035SM	1	WASHER, Flat, 5/8
0220	2860744SM	1	CAPSCREW, Hex Head, 5/8-11 x 3-1/4 G5
0230	1738051YP	1	LINK, Drag
0240	885694YP	1	PEDAL ASSEMBLY, Brake
0250	1735595YP	1	LATCH, Brake Lock
0260	1729576SM	1	BOLT, Shoulder, 5/16-18 x 1-1/8
0270	1727935SM	1	SPACER, Pivot
0280	1736714AYP	1	PEDAL ASSEMBLY, Forward
0290	1727246SM	1	PEDAL, Reverse
0300	1960223SM	2	BOLT, Carriage, 5/16-18 x 1-1/4
0310	1728024SM	1	SPACER, Foot Pedal
0320	1728025BMYP	1	ACTUATOR, RMO Switch
0330	885591AYP	1	BRACKET, Pedal Pivot
0340	1727911ASM	1	PLATE, Bearing
0350	885579AYP	1	LIFT SHAFT ASSEMBLY
0360	1727940SM	1	BRACKET, Sector Support
0370	1751110YP	1	GEAR, Steering
0380	1728122SM	2	SPACER, Sector Gear
0390	1960032SM	2	SCREW, Hex Head, 3/8-16 x 1-1/4, G5
0400	1930645SM	2	NUT, Hex Flange, Two Way Lock, 3/8-16
0420	885508AYP	1	BRACKET, Rear Frame, RH
0430	885509AYP	1	BRACKET, Rear Frame, LH
0440	885532AYP	1	BRACE, Middle Cross

### Footnotes

The above parts group applies to the following Mfg. Nos.:

1696109-00 - EMT17538RDF

1696110-00 - EMT18v38RDF

## Frame & Front Axle Group

885707

NOTE: Unless noted otherwise,  
use the standard hardware torque  
specification chart.

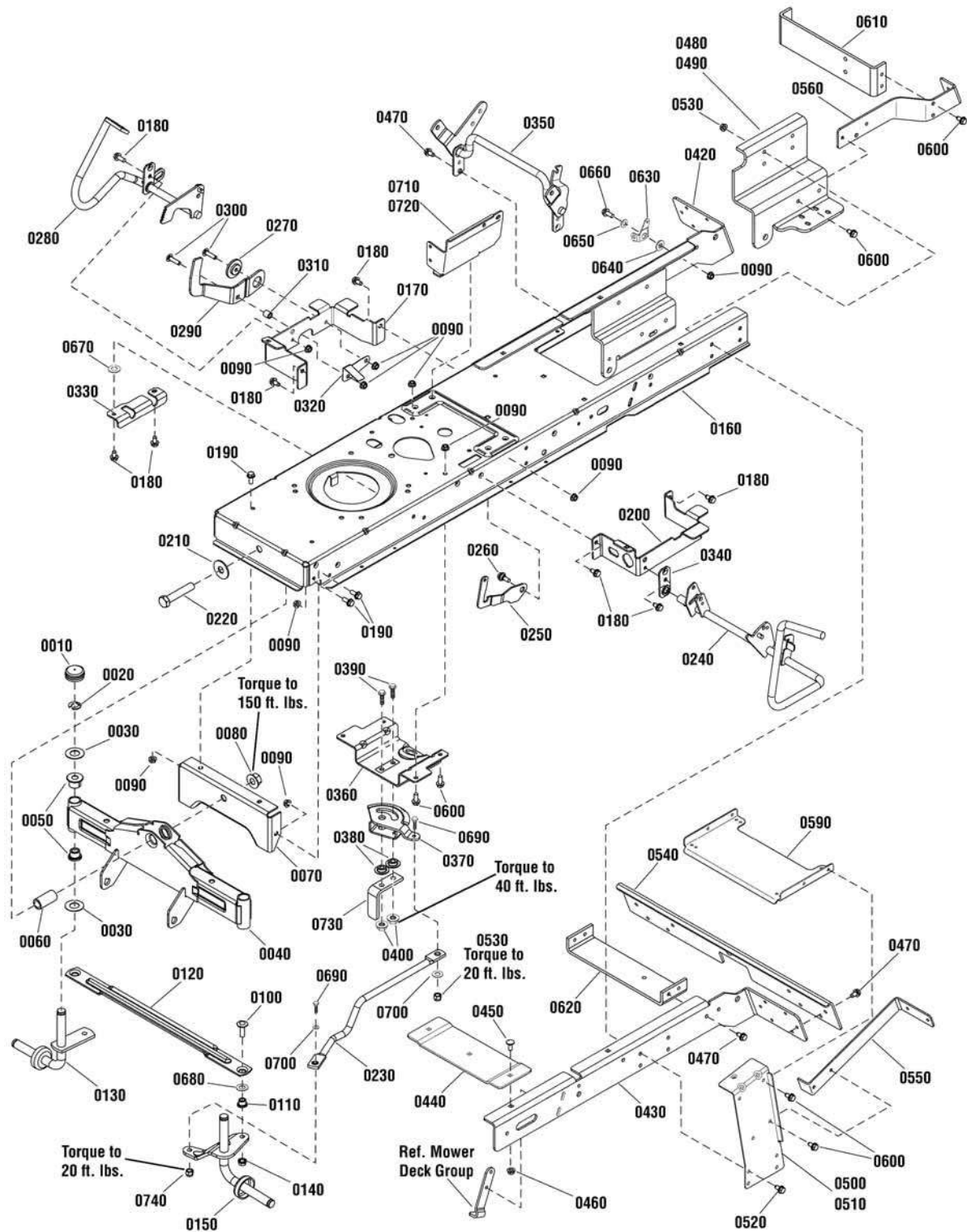

The above parts group applies to the following Mfg. Nos.:

1696109-00 - EMT17538RDF

1696110-00 - EMT18v38RDF

## Frame & Front Axle Group

REF NO	PART NO.	QTY.	DESCRIPTION
0450	1931333SM	5	BOLT, Carriage, Short Neck, 5/16-18 x 3/4, G5
0460	1931277SM	5	NUT, Hex Flange, Whiz Lock, 5/16-18
0470	1664847SM	14	CAPSCREW, Hex Washer Head, Taptite, 5/16-18 x 3/4
0480	885474AYP	1	BRACKET, Transaxle, RH
0490	885475AYP	1	BRACKET, Transaxle, LH
0500	885411AYP	1	SUPPORT, Deck, R.H.
0510	885412AYP	1	SUPPORT, Deck, L.H.
0520	1921333SM	8	CAPSCREW, Hex Head, 5/16-18 x 1, G5
0530	1931277SM	8	NUT, Hex Flange, Whiz Lock, 5/16-18
0540	885469AYP	1	BRACKET, Middle Back Plate
0550	885466AYP	2	SUPPORT, Upper, Back Plate
0560	885467AYP	2	SUPPORT, Lower, Back Plate
0590	885503AYP	1	BRACE, Cross Deck Support
0600	1664847SM	23	CAPSCREW, Hex Washer Head, Taptite, 5/16-18 x 3/4
0610	885441AYP	1	BRACKET, Torque
0620	885486AYP	1	BRACKET, Idler Mount
0630	1728990ASM	1	CLEVIS, Lift
0640	1727935SM	1	SPACER, Pivot
0650	1960044SM	1	WASHER, 5/16
0660	1921333SM	1	CAPSCREW, Hex Head, 5/16-18 x 1, G5
0670	1919326SM	2	WASHER, 5/16
0680	1960703SM	2	WASHER, 5/8
0690	1921977SM	2	CAPSCREW, Hex Head, 5/16-18 x 1-1/4, G5
0700	1924874SM	2	WASHER, 5/16
0710	885695BMYP	1	BRACKET, Tower Support, LH
0720	885696BMYP	1	BRACKET, Tower Support, RH
0730	885791YP	1	UPSTOP
0740	1935048SM	2	NUT, Hex Flange, Two Way Lock, 5/16-18

### Footnotes

The above parts group applies to the following Mfg. Nos.:

1696109-00 - EMT17538RDF

1696110-00 - EMT18v38RDF

## Steering Group

885553

NOTE: Unless noted otherwise, use the standard hardware torque specification chart.

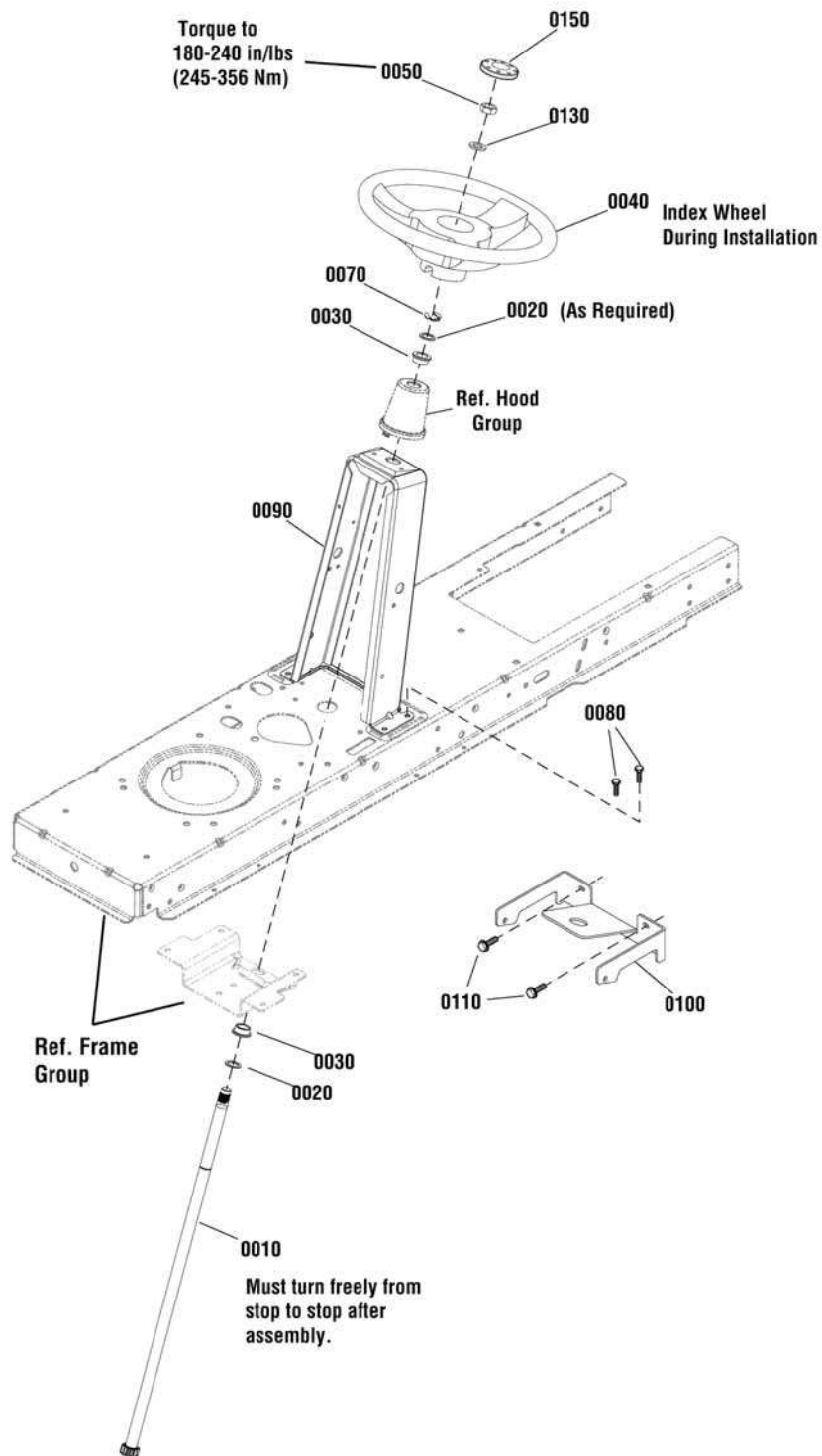

The above parts group applies to the following Mfg. Nos.:

1696109-00 - EMT17538RDF

1696110-00 - EMT18v38RDF



## Steering Group

REF NO	PART NO.	QTY.	DESCRIPTION
0010	1727813SM	1	SHAFT, Steering Gear & Spline Yellow
0020	1960114SM	2	WASHER, 3/4 x 1
0030	1729665SM	2	BUSHING, Steering
0040	1728069SM	1	STEERING WHEEL
0050	1960576SM	1	NUT, Hex Lock, ESNA Light, 5/8-18, Thin
0070	1611710SM	1	RING, Klipring Extension
0080	1930601SM	4	SCREW, Hex Washer Head, Taptite, 5/16-18 x 5/8
0090	885530AYP	1	TOWER
0100	7300653ZYP	1	BRACKET, Tank
0110	1925003SM	2	CAPSCREW, Hex Head, Taptite, 1/4-20 x 1/2
0130	1924366SM	1	WASHER, 5/8 x 1-1/8
0150	1725024SM	1	CAP, Steering Wheel, Plain

Not for  
Reproduction

## Footnotes

---

**The above parts group applies to the following Mfg. Nos.:**

1696109-00 - EMT17538RDF

1696110-00 - EMT18v38RDF

# Engine Group - 17.5HP & 18HP

885676

NOTE: Unless noted otherwise, use the standard hardware torque specification chart.

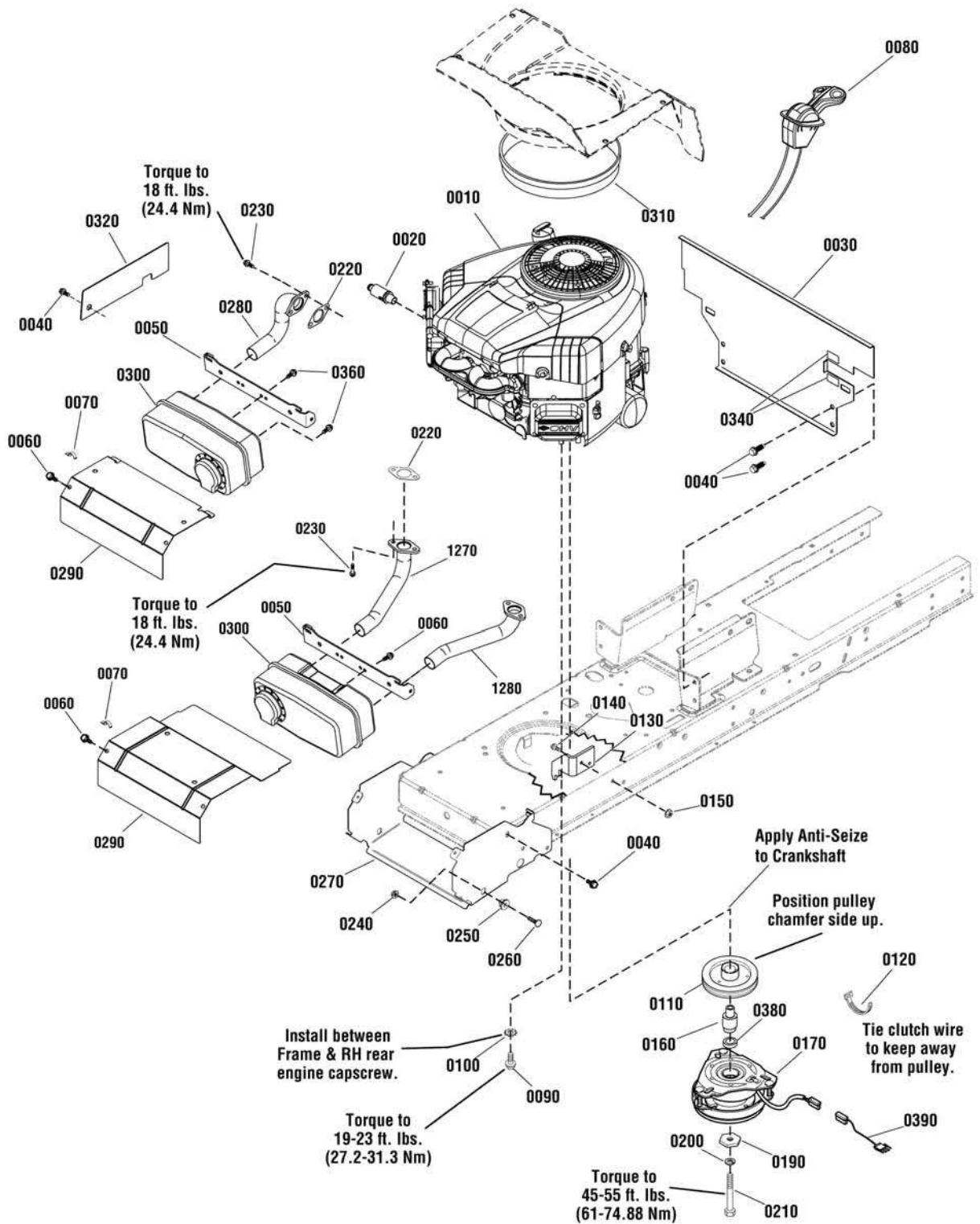

The above parts group applies to the following Mfg. Nos.:

1696109-00 - EMT17538RDF

1696110-00 - EMT18v38RDF

## Engine Group - 17.5HP & 18HP

REF NO	PART NO.	QTY.	DESCRIPTION
0010	31G777-0194-B1	1	* ENGINE, 17.5HP Briggs & Stratton (Engine Model: 31G777-0194-B1)
0010	31G777-0204-B1	1	* ENGINE, 17.5HP Briggs & Stratton (Engine Model: 31G777-0204-B1)
0010	405577-0116-B1	1	* ENGINE, 18HP Briggs & Stratton (Engine Model: 405577-0116-B1)
0020	1750159YP	1	VALVE, Shut Off Oil Drain
0030	885677BMYP	1	HEAT SHIELD
0040	1930601SM	10	SCREW, Hex Washer Head, Taptite, 5/16-18 x 5/8
0050	1727976SM	1	SUPPORT, Muffler
0060	1925003SM	2	SCREW, Hex Washer Head, Taptite, 1/4-20 x 1/2 (Qty 4 used on 18HP Models)
0070	2834683SM	1	WIRE CLIP
0080	1751734YP	1	THROTTLE CONTROL, Choke-A-Matic (Used on 17.5HP Models)
0080	1727817SM	1	THROTTLE CONTROL, Double (Used on 18HP Models)
0090	2827187SM	4	SCREW, Hex Washer, Taptite, 3/8-16 x 1
0100	2820427SM	1	LOCKWASHER, External Tooth
0110	1732576SM	1	PULLEY & HUB ASSEMBLY, Engine
0120	1701011SM	2	TIE, Self Locking
0130	885535AYP	1	BRACKET, Electric Clutch Torque
0140	1921332SM	2	CAPSCREW, Hex Head, 5/16-18 x 3/4, G5
0150	1931277SM	2	NUT, Hex Flange, Whiz Lock, 5/16-18
0160	885679YP	1	SPACER, Electric Clutch
0170	885680YP	1	CLUTCH, Electric
0190	1708264SM	1	WASHER, 7/16
0200	1918199SM	1	LOCKWSHER, Spring
0210	7102075YP	1	CAPSCREW, Hex Head, 7/16-20 x 5
0220	1731214SM	1	GASKET, Exhaust (Qty 2 used on 18HP Models)
0230	690341	2	** SCREW, Hex SEMS Lock Washer 5/16-18 x 7/8 (Qty 4 used on 18HP Models)
0240	1931277SM	2	NUT, Hex Flange, 5/16-18
0250	1728086SM	2	PIVOT, Hood
0260	1931335SM	2	BOLT, Carriage, 5/16-18 x 1
0270	1727982ASM	1	BRACKET, Muffler
0280	1728959SM	1	EXHAUST PIPE, Single (Used on 17.5HP Models)
0290	1727996ASM	1	HEAT SHIELD, Single (Used on 17.5HP Models)
0290	1727997ASM	1	HEAT SHIELD, Twin (Used on 18HP Models)
0300	885615YP	1	MUFFLER, Single (Used on 17.5HP Models)
0300	1727994SM	1	MUFFLER, Twin (Used on 18HP Models)
0310	1734166SM	1	EDGING, Rubber, Single (Used on 17.5HP Models)
0310	1731970SM	1	EDGING, Rubber, Twin (Used on 18HP Models)
0320	1736025BMYP	1	GUARD, Pulley
0340	7070814SM	2	TRIM
0360	1930601SM	3	SCREW, Hex Washer Head, Taptite, 5/16-18 x 5/8
0380	885810YP	1	SPACER, Lower
0390	885815YP	1	HARNESS, Ogura
1270	1727979SM	1	EXHAUST PIPE, RH (Used on 18HP Models)
1280	1727980SM	1	EXHAUST PIPE, LH (Used on 18HP Models)

### Footnotes

Note\* To verify your specific engine model, please reference the ID Tag located on your engine. See your local Briggs & Stratton distributor for parts and service.

Note: \*\* Purchase engine parts from engine manufacture dealer.

### The above parts group applies to the following Mfg. Nos.:

1696109-00 - EMT17538RDF  
1696110-00 - EMT18v38RDF

# Transmission Group

885706

NOTE: Unless noted otherwise, use the standard hardware torque specification chart.

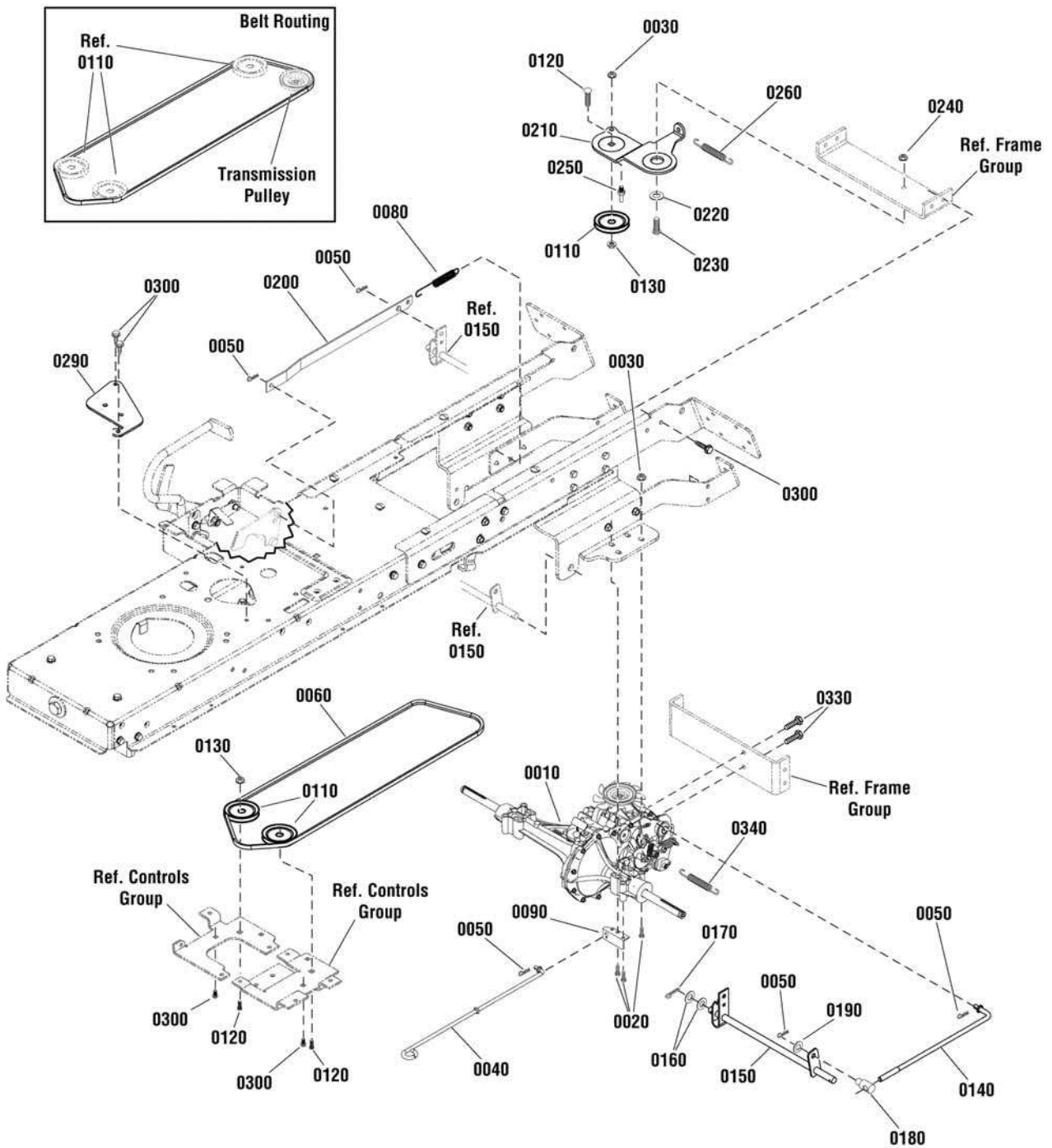

The above parts group applies to the following Mfg. Nos.:

1696109-00 - EMT17538RDF

1696110-00 - EMT18v38RDF

## Transmission Group

REF NO	PART NO.	QTY.	DESCRIPTION
0010	885528YP	1	* TRANSMISSION, Hydro Gear, 610
0020	1923141SM	8	SCREW, Hex Head Flange Lock, 5/16-18 x 2-3/4, G5
0030	1931277SM	8	NUT, Hex Flange, Whiz Lock, 5/16-18
0040	885436YP	1	LEVER, Roll Release
0050	1722460SM	5	PIN, Quick
0060	885495YP	1	BELT, Secondary (81.37" EL, HA section)
0080	165X75MA	1	SPRING, Extension
0090	7300701ZYP	1	BRACKET, Roll Release
0110	885645YP	3	PULLEY, Idler
0120	1931352SM	3	BOLT, Carriage, Short Neck, 3/8-16 x 1-1/2, G5
0130	015X84MA	3	NUT, Hex Flange, Centerlock, 3/8-16
0140	885476YP	1	SPEED CONTROL, Short Link
0150	885477AYP	1	SPEED CONTROL ASSEMBLY
0160	017X91MA	2	WASHER, Flat, 13/16
0170	1960074SM	1	PIN, Cotter
0180	021920ZMA	1	NUT, Adjusting
0190	017X53MA	1	WASHER, Flat, .41
0200	885480AYP	1	LINK, Speed Control
0210	885409AYP	1	BRACKET, Idler, Rear
0220	1727935SM	1	SPACER, Pivot
0230	1931335SM	1	BOLT, Carriage, Short Neck, 5/16-18 x 1, G5
0240	1931277SM	2	NUT, Hex Flange, Whiz Lock, 5/16-18
0250	885077YP	1	BELT GUIDE
0260	1731939SM	1	SPRING, Extension
0290	885681BMYP	1	PLATE, Front Fixed Idler
0300	1664847SM	4	CAPSCREW, Hex Washer Head, Taptite, 5/16-18 x 3/4
0330	1664847SM	2	CAPSCREW, Hex Washer Head, Taptite, 5/16-18 x 3/4
0340	165X92MA	1	SPRING, Extension

### Footnotes

The above parts group applies to the following Mfg. Nos.:

1696109-00 - EMT17538RDF

1696110-00 - EMT18v38RDF

# Transmission SERVICE PARTS - Hydro Gear 324-0610

885528

NOTE: Unless noted otherwise,  
use the standard hardware torque  
specification chart.

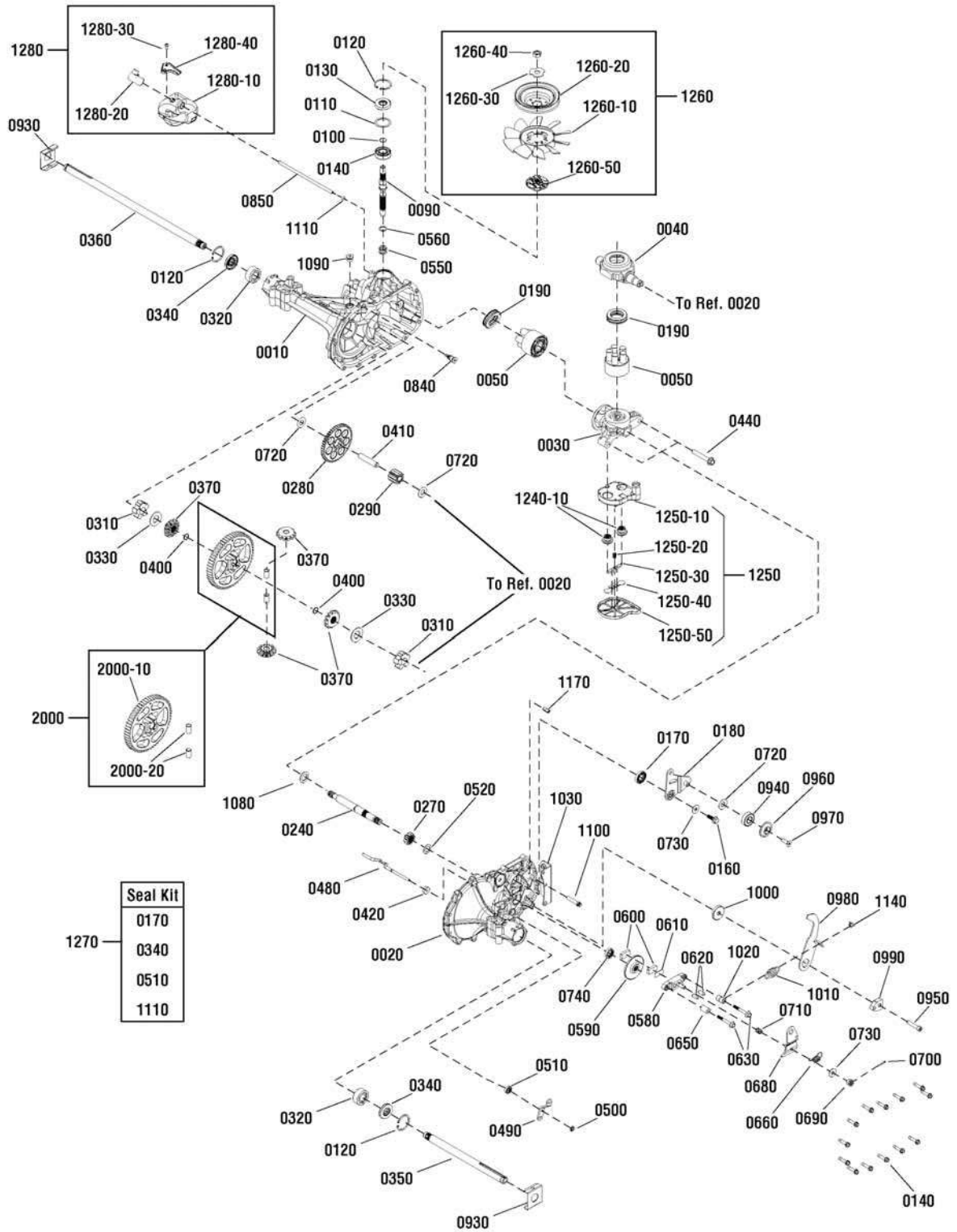

The above parts group applies to the following Mfg. Nos.:

1696109-00 - EMT17538RDF

1696110-00 - EMT18v38RDF

## Transmission SERVICE PARTS - Hydro Gear 324-0610

REF NO	PART NO.	QTY.	DESCRIPTION
0010	----	1	* MAIN HOUSING ASSEMBLY
0020	----	1	* SIDE HOUSING ASSEMBLY
0030	----	1	* CENTERSECTION ASSEMBLY
0040	----	1	* TRUNNION, Swashplate
0050	----	2	* BLOCK ASSEMBLY
0060	----	1	* SEALANT, 10.1 oz. (Not Illustrated)
0070	----	14	* SCREW, Hex Washer, 1/4-20 x 1-1/8
0090	1752461YP	1	SHAFT, Input
0100	1715270SM	1	RING, Retaining
0110	1752462YP	1	WASHER, Flat, 1.23 x 1.57 x .04
0120	1752463YP	3	RING, RETAINING
0130	1752464YP	1	SEAL, LIP 17 x 40 x 12
0140	1752465YP	1	BEARING, BALL 17 x 40 x 12
0160	----	1	* SCREW, Hex Flange, With Patch, 5/16-24 x 15/16
0170	----	1	* SEAL, Lip, 18 x 32 x 7 (Not a servicable part, order kit # 1270)
0180	----	1	* ARM, Control
0190	1715144SM	2	* BEARING, Thrust, 30 x 52 x 13
0240	----	1	* SHAFT, Motor
0270	----	1	* GEAR, Pinion, 12T
0280	----	1	* GEAR, 10T/49T
0290	----	1	* GEAR, Jackshaft, 10T
0310	----	2	* BUSHING, Sleeve (Inboard)
0320	----	2	* BUSHING, Sleeve, 3/4 x 1-1.571 x 5/8
0330	----	2	* WASHER, Flat, 3/4 x 1-1/2 x 7/64
0340	----	2	* SEAL, Lip, 3/4 x 1.577 x 1/4 (Not a servicable part, order kit # 1270)
0350	----	1	* SHAFT, Axle, 3/4 x 11.39 (Key, RH)
0360	----	1	* SHAFT, AXLE, 3/4 x 16.99 (Key, LH)
0370	----	1	* KIT, Miter Gear
0400	----	2	* RING, Retaining Spiral
0410	----	1	* PIN, Jackshaft, 1/2 x 2.43
0420	----	1	* MAGNET, Ring
0440	1717965SM	2	SCREW, Hex Flange, 3/8-24 x 2-1/2
0480	----	1	* ROD, Actuator Bypass
0490	----	1	* ARM, Bypass
0500	----	1	* RING, Retaining, External, 1/4
0510	----	1	* SEAL, Lip, 1/4 x 3/4 x 1/4 TC (Not a servicable part, order kit # 1270)
0520	----	1	* WASHER, Flat, 5/8 x 1 x 1/2
0530	----	1	* RING, Retaining
0540	----	1	* BUSHING, Center Block
0550	----	1	* SPRING, Block
0560	----	1	* WASHER, Thrust, .59 x .79 x .04
0580	----	1	* BRAKE YOKE KIT
0590	----	1	* DISK, Brake

### Footnotes

Note\* See your local authorized dealership for parts and warranty or contact Hydro Gear at [www.hydro-gear.com/Support/NorthAmerica.aspx](http://www.hydro-gear.com/Support/NorthAmerica.aspx) (U.S. 1-877-728-7410 Int'l 32 (0) 12 670 631)

### The above parts group applies to the following Mfg. Nos.:

1696109-00 - EMT17538RDF  
1696110-00 - EMT18v38RDF

# Transmission SERVICE PARTS - Hydro Gear 324-0610

885528

NOTE: Unless noted otherwise,  
use the standard hardware torque  
specification chart.

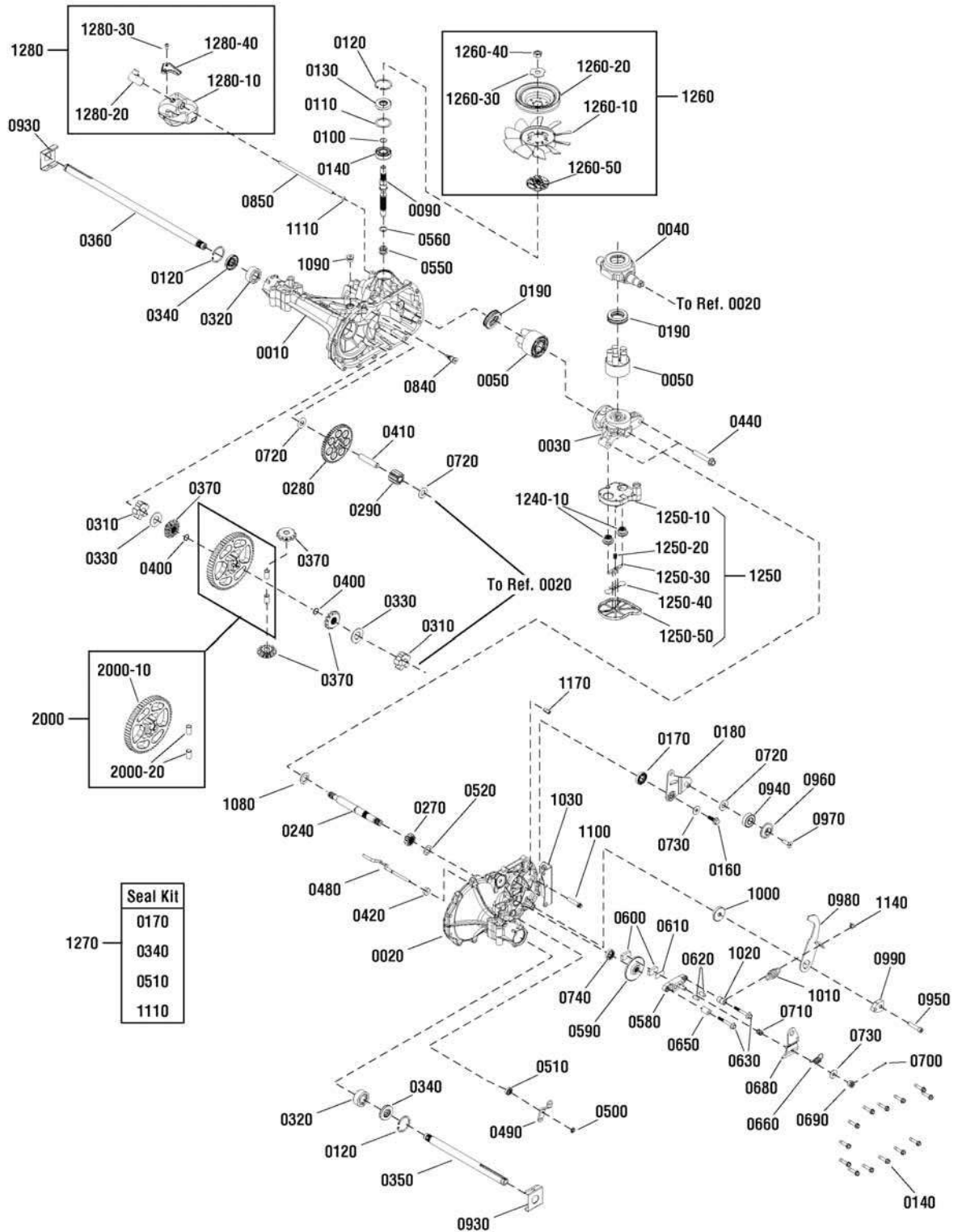

The above parts group applies to the following Mfg. Nos.:

- 1696109-00 - EMT17538RDF
- 1696110-00 - EMT18v38RDF



## Transmission SERVICE PARTS - Hydro Gear 324-0610

REF NO	PART NO.	QTY.	DESCRIPTION
0600	----	2	* PUCK, Brake
0610	----	1	* PLATE, Puck
0620	----	2	* PIN, Brake Actuating
0630	----	2	* SCREW, Hex Head, With Patch, 1/4-20 x 2
0650	1715199SM	1	SPACER, .26 x .57 x .87
0660	----	1	* SPRING, Brake arm Bias
0670	1706160SM	1	SCREW, Square Head, Ribbed, 5/16-24
0680	----	1	* ARM, Brake
0690	----	1	* NUT, Castle, 5/16-24
0700	----	1	* PIN, Cotter, 3/32 x 3/4
0710	----	1	* SPRING, Compression Brake, Anti-Drag
0720	----	3	* WASHER, Flat, .51 x 1.0 x .03
0730	----	2	* WASHER, Flat, .34 x .88 x .06
0740	----	1	* KIT, Seal
0840	----	1	* FITTING, 5/16 SAE 5/32 TUBE
0850	----	1	* HOSE, Expansion Tank, 7.56 In.
0930	1752466YP	2	SPRING CLIP, Housing Thrust (3/4" Axle)
0940	----	1	* BEARING, Ball, .62 x 1.38 x .44
0950	----	1	* CAPSCREW, Socket Head, 5/16-24 x 1-1/2
0960	----	1	* SPACER, Locating
0970	----	1	* SCREW, Countersunk, 5/16-18 x 1
0980	----	1	* ARM, Return
0990	----	1	* PUCK, Adjusting
1000	----	1	* WASHER, Flat, .32 x 1.60 x .24
1020	----	1	* SPACER, .26 x .56 x .87
1010	----	1	* SPRING, Extension, Double Loop
1030	----	1	* BRACKET, Torque
1080	----	1	* WASHER, Flat, .71 x 1.16 x .04
1090	----	1	* PLUG, 9/16-18 (METAL)
1100	----	1	* SCREW, Torx Head, 5/16-18 x 1-1/2
1110	----	1	* O-RING, .299 x .505 x .103 (Not a serviceable part, order kit # 1270)
1140	----	1	* SPRING, Guide
1170	----	1	* PIN, Spring, .304 x .75
1240	----	1	* CENTERSECTION ASSEMBLY, Filter, Bypass (Not Illustrated) (Includes Ref. Nos. 0030, 1240-10 & 1250)
1240-10	----	1	* CENTERSECTION (5-Piston) (Not a serviceable part, order kit #1240)
1250	----	1	* FILTER ASSEMBLY (Includes Ref. Nos. 1250-10, 1250-20, 1250-30, 1250-40 & 1250-50)
1250-10	----	1	* BASE, Filter, With Poppet (Not a serviceable part, order kit #1250)
1250-20	----	1	* SPRING, Bypass, 1/2" (Not a serviceable part, order kit #1250)
1250-30	----	1	* ACTUATOR, Bypass (Not a serviceable part, order kit #1250)
1250-40	----	1	* DEFLECTOR (Not a serviceable part, order kit #1250)
1250-50	----	1	* BOTTOM, Filter (Not a serviceable part, order kit #1250)

### Footnotes

Note\* See your local authorized dealership for parts and warranty or contact Hydro Gear at [www.hydro-gear.com/Support/NorthAmerica.aspx](http://www.hydro-gear.com/Support/NorthAmerica.aspx) (U.S. 1-877-728-7410 Int'l 32 (0) 12 670 631)

### The above parts group applies to the following Mfg. Nos.:

1696109-00 - EMT17538RDF  
1696110-00 - EMT18v38RDF

# Transmission SERVICE PARTS - Hydro Gear 324-0610

885528

NOTE: Unless noted otherwise,  
use the standard hardware torque  
specification chart.

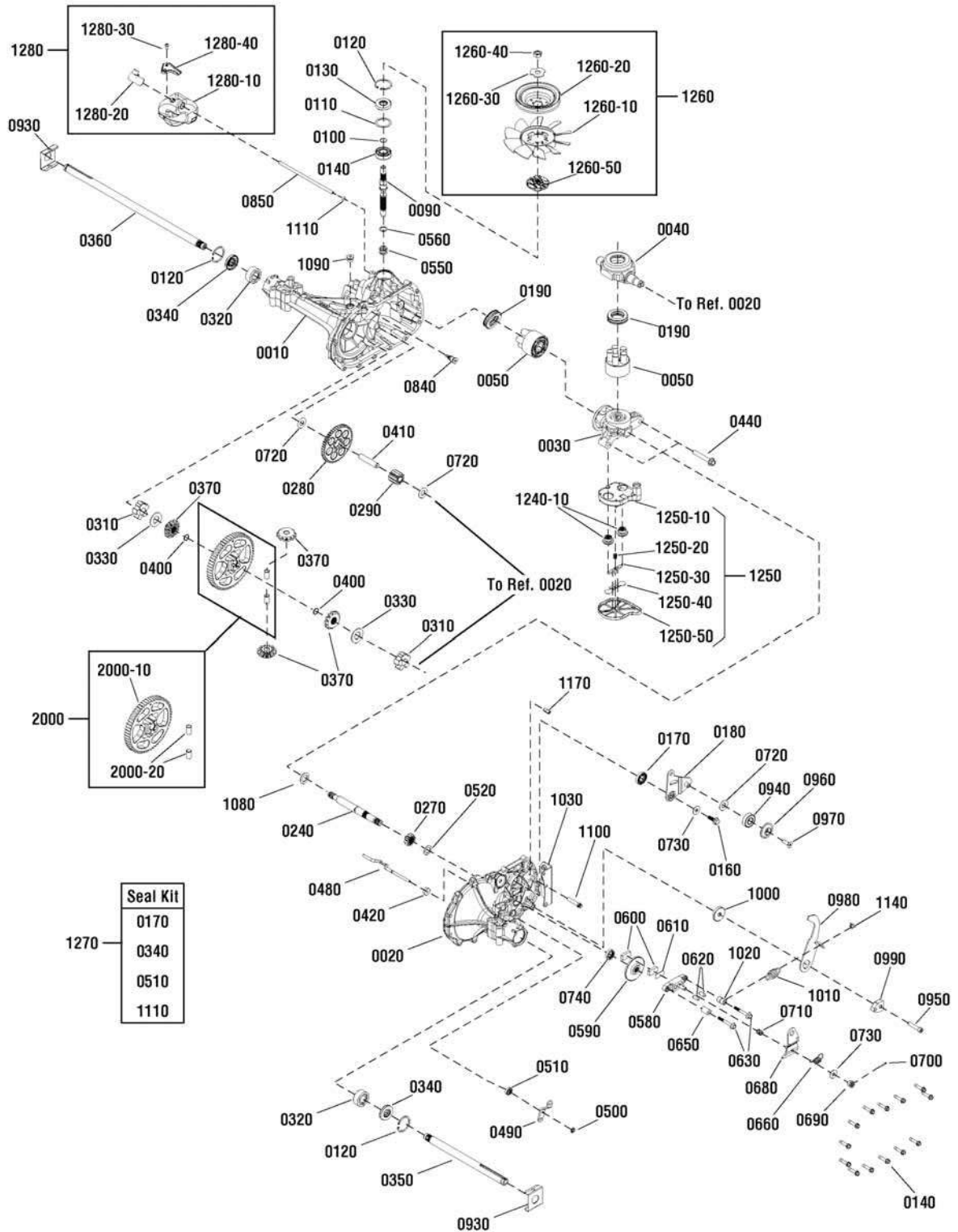

The above parts group applies to the following Mfg. Nos.:

1696109-00 - EMT17538RDF

1696110-00 - EMT18v38RDF

## Transmission SERVICE PARTS - Hydro Gear 324-0610

REF NO	PART NO.	QTY.	DESCRIPTION
1260-20	-----	1	* PULLEY, Cupped, 4-1/2" (Not a serviceable part, order kit #1260)
1260-30	-----	1	* NUT, Hex Jam, With Patch, 1/2-20 (Not a serviceable part, order kit #1260)
1260-40	-----	1	* WASHER, Slotted, .53 x 1.63 x .06 (Not a serviceable part, order kit #1260)
1260-50	-----	1	* HUB, Pulley (Not a serviceable part, order kit #1260)
1270	1752468YP	1	SEAL & O-RING KIT (Includes Ref. Nos. 0170, 0340, 0510 & 1110)
1280	1752469YP	1	EXPANSION TANK KIT (Includes Ref. Nos. 1280-10, 1280-20, 1280-30 & 1280-40)
1280-10	-----	1	* TANK, Expansion (Not a serviceable part, order kit #1280)
1280-20	-----	1	* CAP, Expansion Tank (Not a serviceable part, order kit #1280)
1280-30	-----	1	* BOLT, Self Tapping, 10-32 x 1/2 (Not a serviceable part, order kit #1280)
1280-40	-----	1	* BRACKET, Expansion Tank (Not a serviceable part, order kit #1280)
2000	-----	1	* KIT, 60T Bull Gear Diff Pins (Includes Ref. Nos. 2000-10 & 2000-20)
2000-10	-----	1	* GEAR, 60T
2000-20	-----	2	* PIN, 1/2

Not for  
Reproduction

### Footnotes

Note\* See your local authorized dealership for parts and warranty or contact Hydro Gear at [www.hydro-gear.com/Support/NorthAmerica.aspx](http://www.hydro-gear.com/Support/NorthAmerica.aspx) (U.S. 1-877-728-7410 Int'l 32 (0) 12 670 631)

---

### The above parts group applies to the following Mfg. Nos.:

1696109-00 - EMT17538RDF  
1696110-00 - EMT18v38RDF

## Controls Group

885682

NOTE: Unless noted otherwise, use the standard hardware torque specification chart.

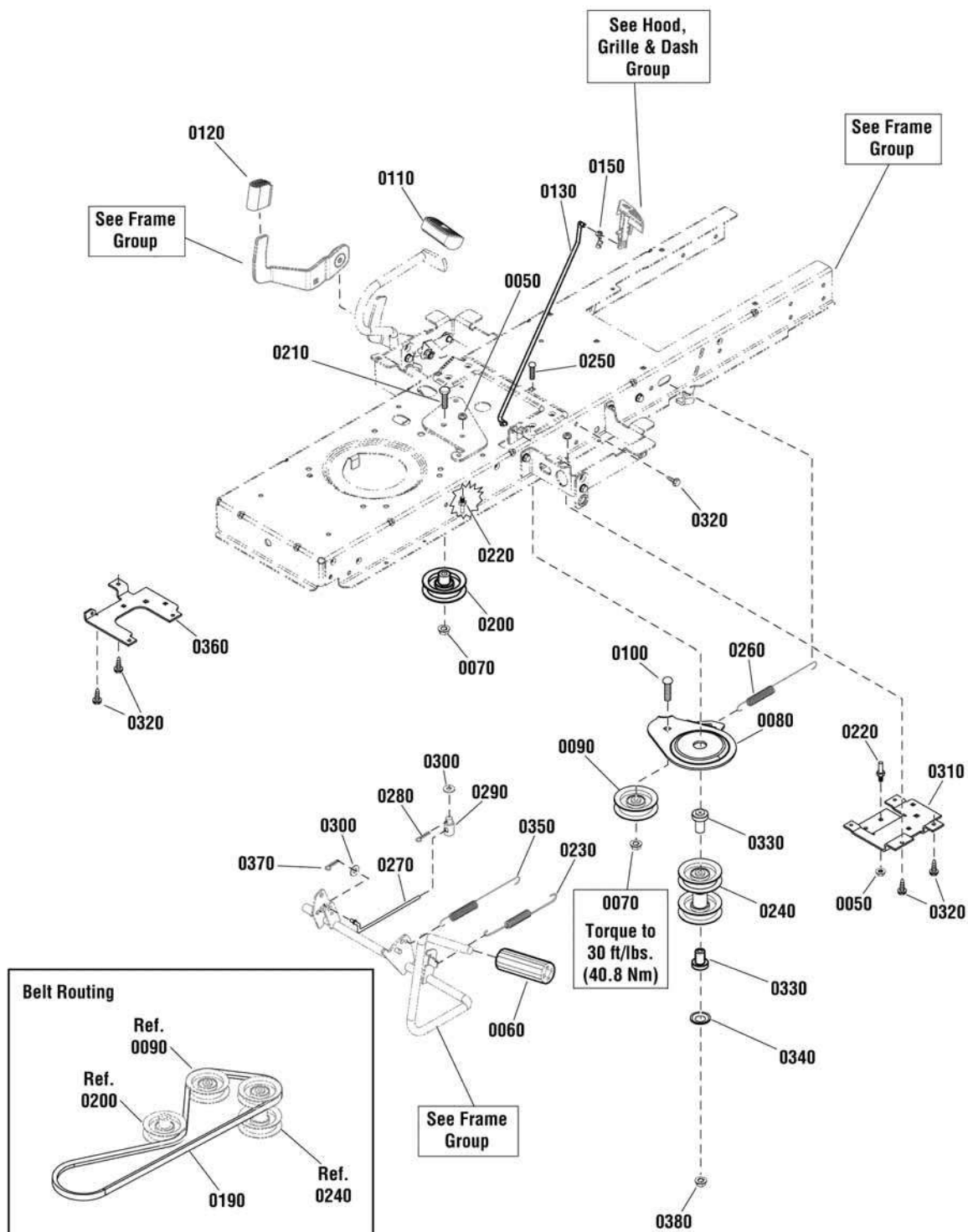

The above parts group applies to the following Mfg. Nos.:

1696109-00 - EMT17538RDF

1696110-00 - EMT18v38RDF

## Controls Group

REF NO	PART NO.	QTY.	DESCRIPTION
0050	1931277SM	2	NUT, Hex, Flange Whizlock, 5/16-18
0060	1727261SM	1	PEDAL, Brake Rubber
0070	1960687SM	2	NUT, Hex Flange, ESNA, 3/8-16
0080	885410AYP	1	BRACKET, Idler Front Movable
0090	885645YP	1	PULLEY, 3 OD Plastic
0100	1931352SM	1	BOLT, Carriage, 3/8-16 x 1-1/2
0110	1721675SM	1	PAD, Foot Pedal Forward
0120	1727259SM	1	PAD, Foot Pedal Reverse
0130	1727267SM	1	ROD, Parking Brake, 16-3/8"
0150	1728111SM	1	CLIP, Linkage, Black
0190	885484YP	1	BELT, Primary, M/D
0200	885565YP	1	IDLER, Backside
0210	1921971SM	1	CAPSCREW, Hex Head, 3/8-16 x 1-3/4, G5
0220	885534YP	2	BELT GUIDE
0230	885421YP	1	SPRING, Extension
0240	885426YP	1	PULLEY, Secondary Stack
0250	885577YP	1	BOLT, Carriage, 3/8-16 x 5
0260	1729620SM	1	SPRING, Extension 7-1/2"
0270	885683YP	1	ROD, Clutch
0280	7091809YP	1	PIN, Cotter
0290	021920ZMA	1	NUT, Adjusting
0300	1960103SM	2	WASHER, 3/8
0310	885684BMYP	1	BRACKET, Stack Pulley, Left
0320	1664847SM	4	SCREW, Hex Washer Head, Taptite, 5/16-18 x 3/4
0330	885575YP	2	SPACER
0340	1931942SM	1	NUT, Push Pal, 3/8
0350	1721995SM	1	SPRING, Extension
0360	885685BMYP	1	BRACKET, Stack Pulley, Right
0370	1918447SM	1	PIN, Cotter
0380	015X84MA	1	NUT, Hex Flange, Centerlock, 3/8-16

## Footnotes

The above parts group applies to the following Mfg. Nos.:

1696109-00 - EMT17538RDF

1696110-00 - EMT18v38RDF

## Electrical Group

885690

NOTE: Unless noted otherwise,  
use the standard hardware torque  
specification chart.

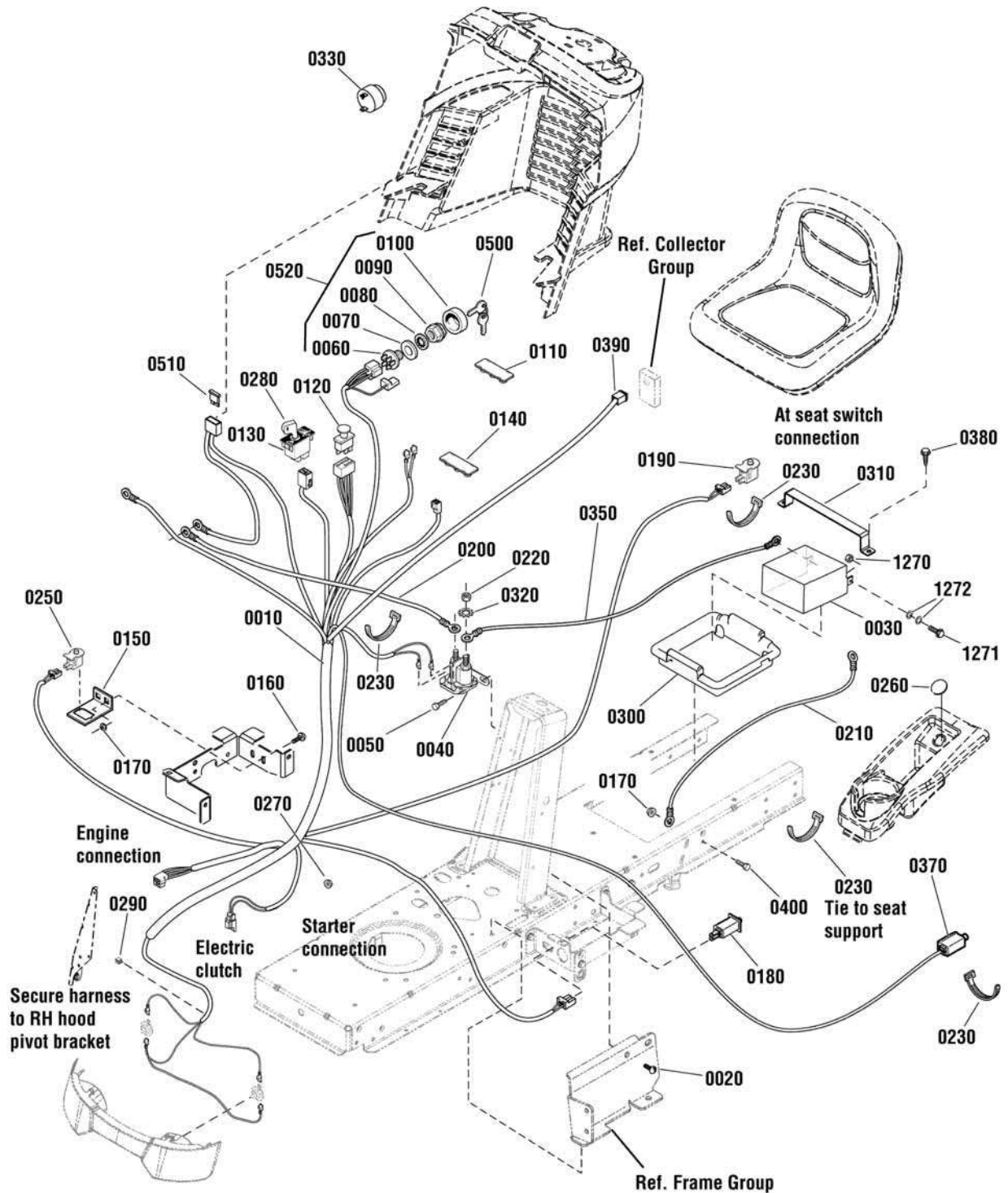

The above parts group applies to the following Mfg. Nos.:

1696109-00 - EMT17538RDF

1696110-00 - EMT18v38RDF

## Electrical Group

REF NO	PART NO.	QTY.	DESCRIPTION
0010	885691YP	1	WIRING HARNESS
0020	1930601SM	5	CAPSCREW, Hex Washer Head, Taptite, 5/16-18 x 5/8
0030	-----	1	BATTERY, 12V18AH
0040	1728963SM	1	SOLENOID
0050	1925003SM	2	CAPSCREW, Hex Washer Head, Taptite, 1/4-20 x 1/2
0060	092556MA	1	SWITCH ASSEMBLY, Ignition
0070	2101025SM	1	WASHER, 5/8
0080	1960547SM	1	LOCKWASHER, Internal Tooth
0090	1717549SM	1	NUT, Hex Flange, 5/8-32
0100	1717550SM	1	COVER, Switch
0110	1729993SM	1	PLUG, Hour Meter
0120	1722887SM	1	SWITCH, PTO Push
0130	1726556SM	1	SWITCH, RMO Module Only
0140	1722611SM	2	PLUG, Hole
0150	1728026ASM	1	SUPPORT, RMO Switch
0160	1931333SM	2	BOLT, Carriage, 5/16-18 x 3/4 G5
0170	1931277SM	3	NUT, Hex Flange Whiz Lock Small, 5/16-18
0180	7022886YP	1	SWITCH, Push Button (NO / NC)
0190	7023354YP	1	SWITCH, Push Button (NC)
0200	1721830SM	1	CABLE, # 6 x 25, Red
0210	1713163SM	1	CABLE, # 6 x 26, Black
0220	2860750SM	2	NUT, Hex, KEPS, 5/16-24
0230	1701011SM	16	TIE, Self Locking
0250	1732004SM	1	SWITCH, Push Button (NO)
0260	1732007SM	1	PLUG, Hole
0270	1960294SM	1	NUT, Hex Flange Whiz Lock Small, 1/4-20
0280	1726557SM	2	KEY, RMO Module Plastic
0290	2172434SM	1	CLIP, Wire
0300	885428YP	1	CONTAINER, Battery
0310	885511AYP	1	HOLD DOWN, Battery
0320	2820426SM	2	LOCKWASHER, 5/16
0330	1720117SM	1	BUZZER, Bag Full
0350	885616YP	1	CABLE, Battery
0370	1001845MA	1	SWITCH, Bagger
0380	1664847SM	2	SCREW, Hex Washer Head, Taptite, 5/16-18 x 3/4
0390	885692YP	1	HARNESS, Bag Full
0400	7091811SM	1	CAPSCREW, Hex Flange, 5/16-18 x 5/8, G5
0500	1737837YP	1	KEYS, Ignition
0510	-----	1	* FUSE, 20 Amp
0520	1686734YP	1	SWITCH ASSEMBLY (Includes Ref Nos. 0060, 0070, 0080, 0090 & 0100)
1270	51716GS	2	NUT, M5 x 0.8
1271	52618GS	2	SCREW, M5 x 0.8 x 12
1272	51713GS	4	WASHER, M5

### Footnotes

The above parts group applies to the following Mfg. Nos.:

1696109-00 - EMT17538RDF

1696110-00 - EMT18v38RDF





## Hood, Grille & Dash Group

REF NO	PART NO.	QTY.	DESCRIPTION
0010	1728031BIYP	1	HOOD, With Scoop
0020	7102326YP	1	AIR DUCT, Plenum
0030	1727294BIYP	1	PANEL, Side, R.H.
0040	1727295BIYP	1	PANEL, Side, L.H.
0050	1738914BIYP	1	GRILLE
0060	1727279ASM	1	HINGE, Hood, L.H.
0070	1727280ASM	1	HINGE, Hood, R.H.
0080	1960295SM	12	CAPSCREW, Hex Flange Whiz Lock, 1/4-20 x 5/8
0090	1930641SM	12	NUT, Hex Flange Whiz Lock Large, 1/4-20
0100	885571YP	1	CONSOLE
0110	1728089SM	1	KNOB, Brake Lock, Red
0130	1960518SM	2	PUSHNUT, 1/4
0140	1664847SM	2	CAPSCREW, Hex Washer Head, Taptite, 5/16-18 x 3/4
0150	1919381SM	2	WASHER, 5/16
0160	1739106YP	1	COVER
0170	1727296SM	1	HEADLIGHT ASSEMBLY
0170-10	1728973SM	1	REFLECTOR
0170-20	1728974SM	1	LENS, Headlight
0170-30	1677371SM	2	BULB, Headlight, 1141-12V 21CP
0170-40	1723451SM	2	SOCKET
0180	1728975SM	1	INSERT, Lightbar
0190	1960392SM	3	SCREW, Pan Head Phillips, #10-24 x 1/2
0200	885435AYP	1	ROD, Bagger Support
0210	1933896SM	3	NUT, Nylock, 10-24
0220	1925003SM	1	CAPSCREW, Hex Washer Head, Taptite, 1/4-20 x 1/2
0230	028X83MA	6	CLIP
0240	1732030SM	1	GUIDE, Hood, LH
0250	1732031SM	1	GUIDE, Hood, RH
0260	1741762MA	1	INSERT, Grille, Center
0270	1741763MA	1	INSERT, Grille, LH
0280	1741764MA	1	INSERT, Grille, RH
0290	885753YP	1	PLUG, Cruise Control

### Footnotes

The above parts group applies to the following Mfg. Nos.:

1696109-00 - EMT17538RDF

1696110-00 - EMT18v38RDF

## Seat Deck & Fuel Tank Group

885776

NOTE: Unless noted otherwise,  
use the standard hardware torque  
specification chart.

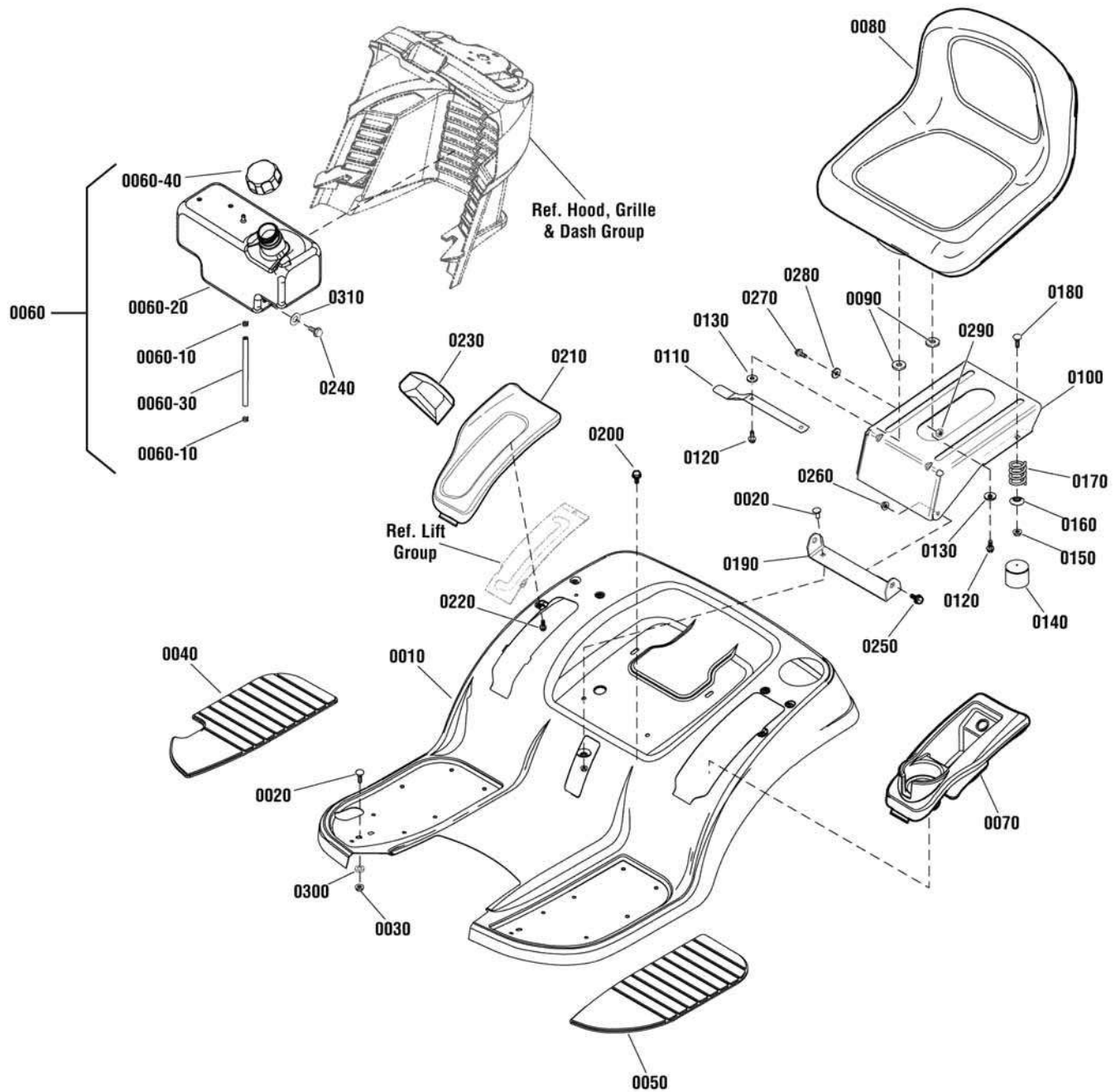

The above parts group applies to the following Mfg. Nos.:

1696109-00 - EMT17538RDF

1696110-00 - EMT18v38RDF

## Seat Deck & Fuel Tank Group

REF NO	PART NO.	QTY.	DESCRIPTION
0010	885687BIYP	1	DECK, Seat
0020	1931333SM	4	BOLT, Carriage, 5/16-18 x 3/4 G5
0030	1931277SM	4	NUT, Hex Flange Whiz Lock Small, 5/16-18
0040	1739014YP	1	PAD, Footrest, RH
0050	1739013YP	1	PAD, Footrest, LH
0060	885548YP	1	FUEL TANK ASSEMBLY (Includes Ref. Nos. 0060-10, 0060-20, 0060-30 & 0060-40)
0060-10	095197MA	2	CLAMP, Hose
0060-20	-----	1	TANK, Fuel (Not a serviceable part, order Ref. 0060)
0060-30	7200118YP	1	HOSE, Fuel
0060-40	092317MA	1	CAP, Gas
0070	1739536YP	1	POD, LH
0080	1730158SM	1	SEAT, Lo Back
0090	1731300SM	4	SPACER, 5/16 ID x 1-1/4 OD x 5/16
0100	1727265SM	1	SUPPORT, Seat
0110	1727268AYP	1	LATCH, Seat
0120	1960667SM	4	CAPSCREW, Hex Flange Whiz Lock, 5/16-18 x 1
0130	1919381SM	4	WASHER, 5/16
0140	1704724SM	2	COVER, Spring
0150	1960686SM	2	NUT, Hex Flange, ESNA, 5/16-18
0160	1709256SM	4	WASHER, Spring
0170	1704728SM	2	SPRING, Compression
0180	1960282SM	2	BOLT, Carriage, 5/16-18 x 3/4 G5
0190	885538AYP	1	PIVOT, Seat
0200	1930601SM	2	CAPSCREW, Hex Washer Head, Taptite, 5/16-18 x 5/8
0210	1739538YP	1	POD, RH
0220	1960536SM	6	SCREW, Hex Washer Head, Plastite, 1/4 x 1/2
0230	1722302SM	1	GRIP
0240	1921958SM	2	CAPSCREW, Hex Head, 1/4-20 x 1/2, G5
0250	1729576SM	2	BOLT, Shoulder, 5/16-18
0260	1960686SM	2	NUT, Hex Flange, ESNA, 5/16-18
0270	1923114SM	1	CAPSCREW, Hex Head, 1/2-13 x 1, G5
0280	1960170SM	1	WASHER, 1/2
0290	5025038SM	1	NUT, Hex, 1/2-13
0300	885382YP	2	WASHER, Rubber
0310	1960353SM	2	WASHER, 1/4

### Footnotes

The above parts group applies to the following Mfg. Nos.:

1696109-00 - EMT17538RDF

1696110-00 - EMT18v38RDF

# Lift Group

885450

NOTE: Unless noted otherwise,  
use the standard hardware torque  
specification chart.

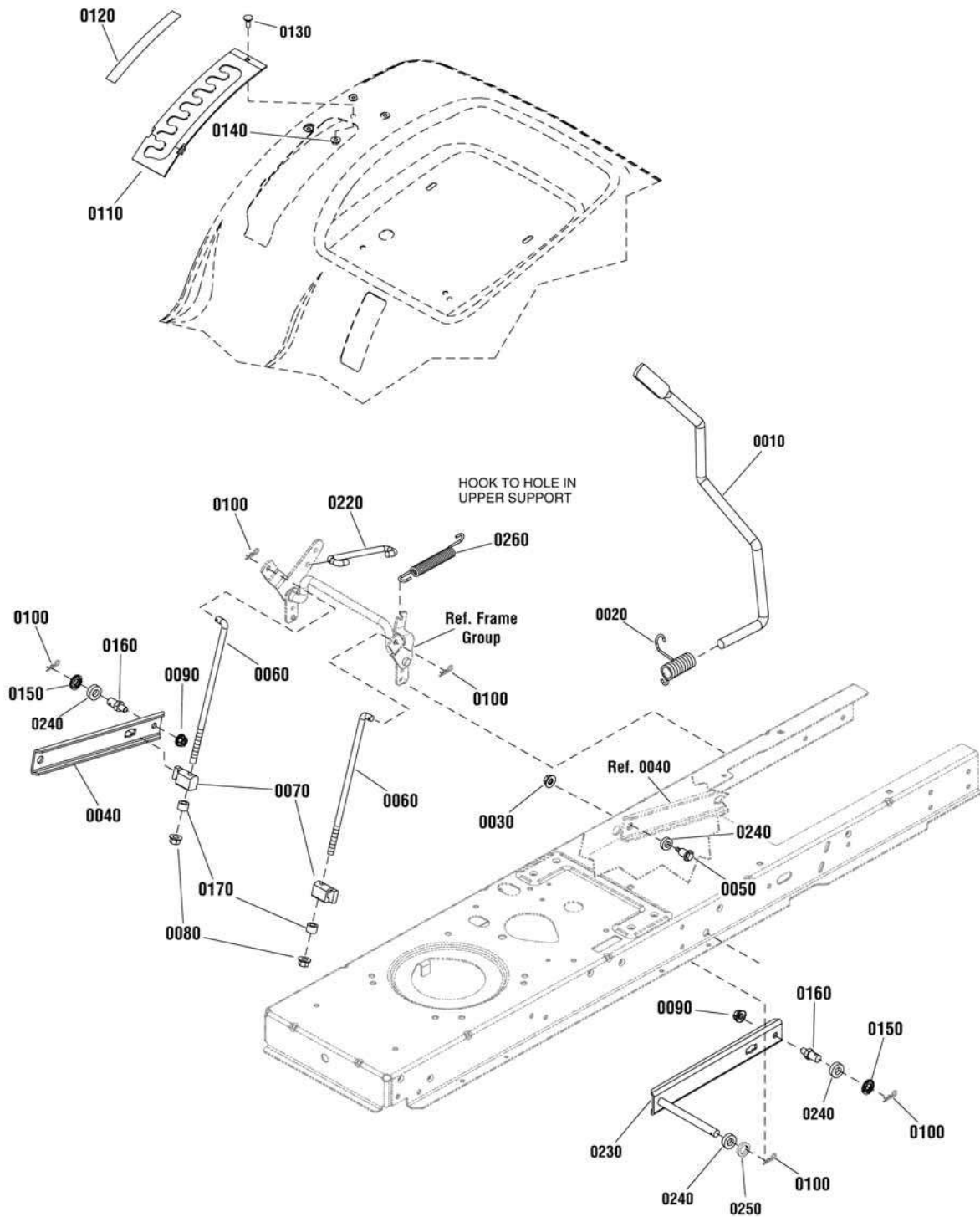

The above parts group applies to the following Mfg. Nos.:

1696109-00 - EMT17538RDF

1696110-00 - EMT18v38RDF

## Lift Group

REF NO	PART NO.	QTY.	DESCRIPTION
0010	1728070SM	1	ROD, Lift Handle, 17.7"
0020	1729652SM	1	SPRING, Torsion, 2.12"
0030	1931277SM	1	NUT, Hex, Flange Whizlock, 5/16-18
0040	1731417SM	1	ARM, Rear Lift, RH
0050	1732426SM	1	BOLT, Shoulder
0060	1727955SM	2	ROD, Lower Life, 10"
0070	1731894SM	2	TRUNNION
0080	1960687SM	2	NUT, Hex Flange, ESNA, 3/8-16
0090	1931211SM	2	NUT, Hex, Flange Lock, 3/8-16
0100	1960074SM	5	CLIP, Spring
0110	1727985SM	1	QUADRANT, Lift Height
0120	1730264SM	1	DECAL, Height Of Cut
0130	1960252SM	1	BOLT, Carriage, 1/4-20 x 5/8, G5
0140	1930641SM	1	NUT, Hex Flange Whiz, 1/4-20
0150	1960170SM	2	WASHER, 1/2
0160	094067MA	2	PIN, Threaded Shoulder
0170	1666294SM	2	SPACER
0220	1727954SM	1	ROD, Lift, 5.43"
0230	885523AYP	1	ARM, Rear Lift, LH
0240	885382YP	4	WASHER, Rubber
0250	017X91MA	1	WASHER, Flat, .81
0260	165X157MA	1	SPRING, Extension

Not for  
Reproduction

## Footnotes

The above parts group applies to the following Mfg. Nos.:

1696109-00 - EMT17538RDF

1696110-00 - EMT18v38RDF

## Wheel & Tires Group

W885820

NOTE: Unless noted otherwise, use the standard hardware torque specification chart.

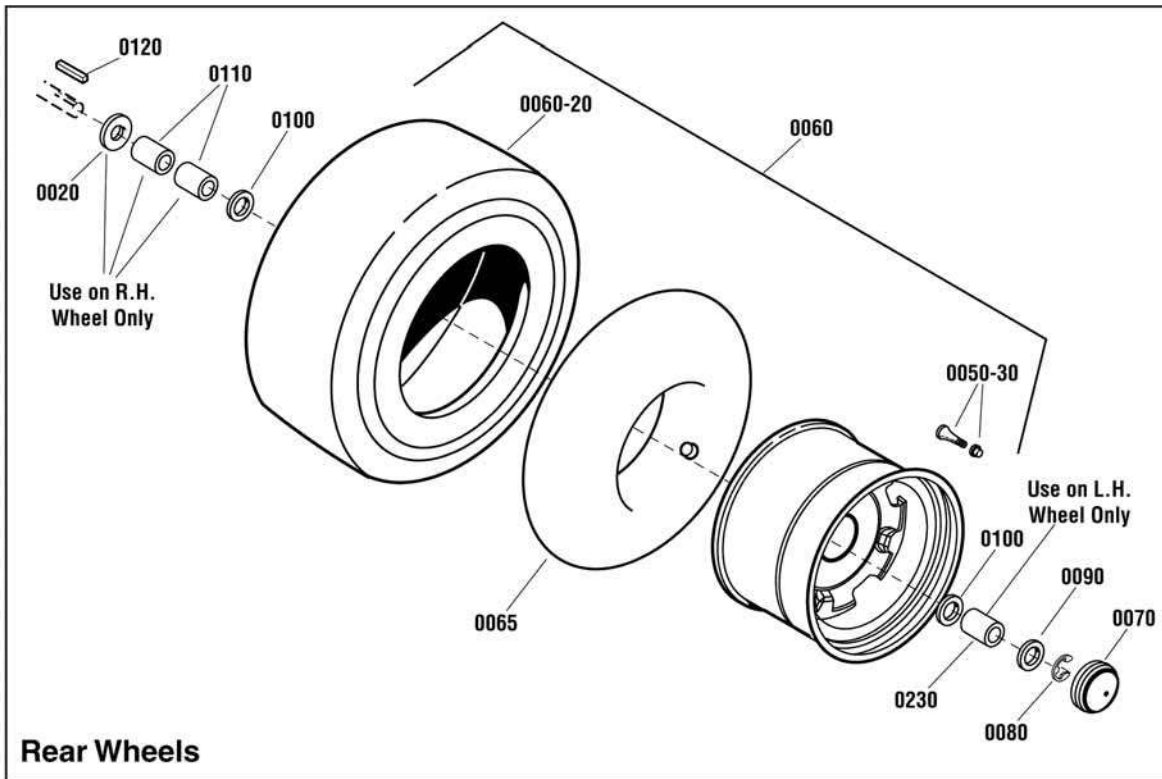
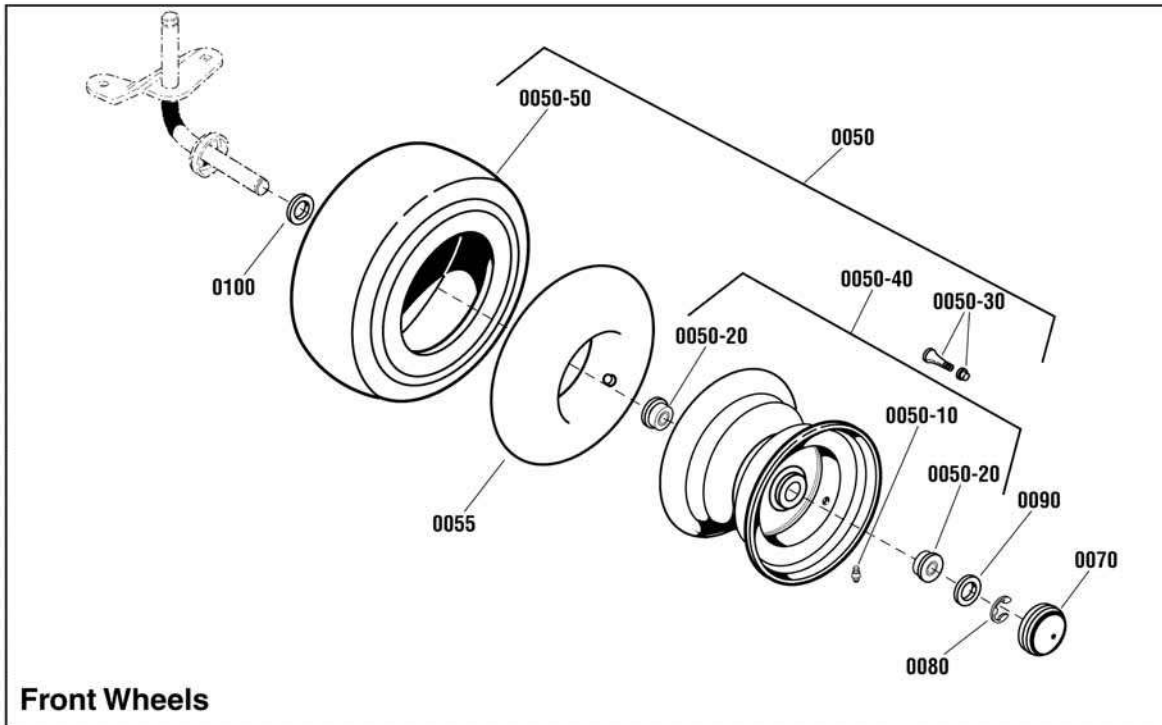

The above parts group applies to the following Mfg. Nos.:

1696109-00 - EMT17538RDF

1696110-00 - EMT18v38RDF

## Wheel & Tires Group

REF NO	PART NO.	QTY.	DESCRIPTION
0020	2860202SM	1	WASHER, 3/4
0050	1729708SM	2	WHEEL& TIRE ASSEMBLY, Front (Includes Ref. Nos. 0050-10, 0050-20, 0050-30, 0050-40 & 0050-50)
0050-10	2812808SM	1	FITTING, Lube
0050-20	1713167SM	2	BEARING, 3/4
0050-30	2172353SM	4	VALVE STEM & CAP
0050-40	1726301SM	1	WHEEL & BUSHINGS ASSEMBLY, Front (Includes Ref. Nos. 0050-10 & 0050-30)
0050-50	1731951SM	1	TIRE, Kenda, Turf Rider, Front, 15 x 6.00 - 6
0055	1664090SM	2	TUBE, Tire, Front
0060	885457YP	2	WHEEL & TIRE ASSEMBLY, Rear, 20 X 8-8 (Includes Ref. Nos. 0050-30 & 0060-20)
0060-20	-----	1	TIRE, Rear, K358 x 20 x 8.94-8 (Not a serviceable part, order Ref. 0060)
0065	2164247SM	2	TUBE, Tire, Rear
0070	094618MA	4	HUB CAP
0080	0011X3MA	4	E-RING
0090	17X195MA	4	WASHER, Flat
0100	17X160MA	4	WASHER, Flat, 3/4 x 1-1/4
0110	1730181SM	2	SPACER, 3/4 ID x 1-1/4 OD x 1-5/8, RH (Use on R.H. Side Only)
0120	021553MA	2	KEY, Square, 3/16
0230	885578YP	1	SPACER, Wheel, LH (Use on L.H. Side Only)

Not for  
Reproduction

### Footnotes

The above parts group applies to the following Mfg. Nos.:

1696109-00 - EMT17538RDF

1696110-00 - EMT18v38RDF

## Decal Group

NOTE: Unless noted otherwise,  
use the standard hardware torque  
specification chart.

D885820

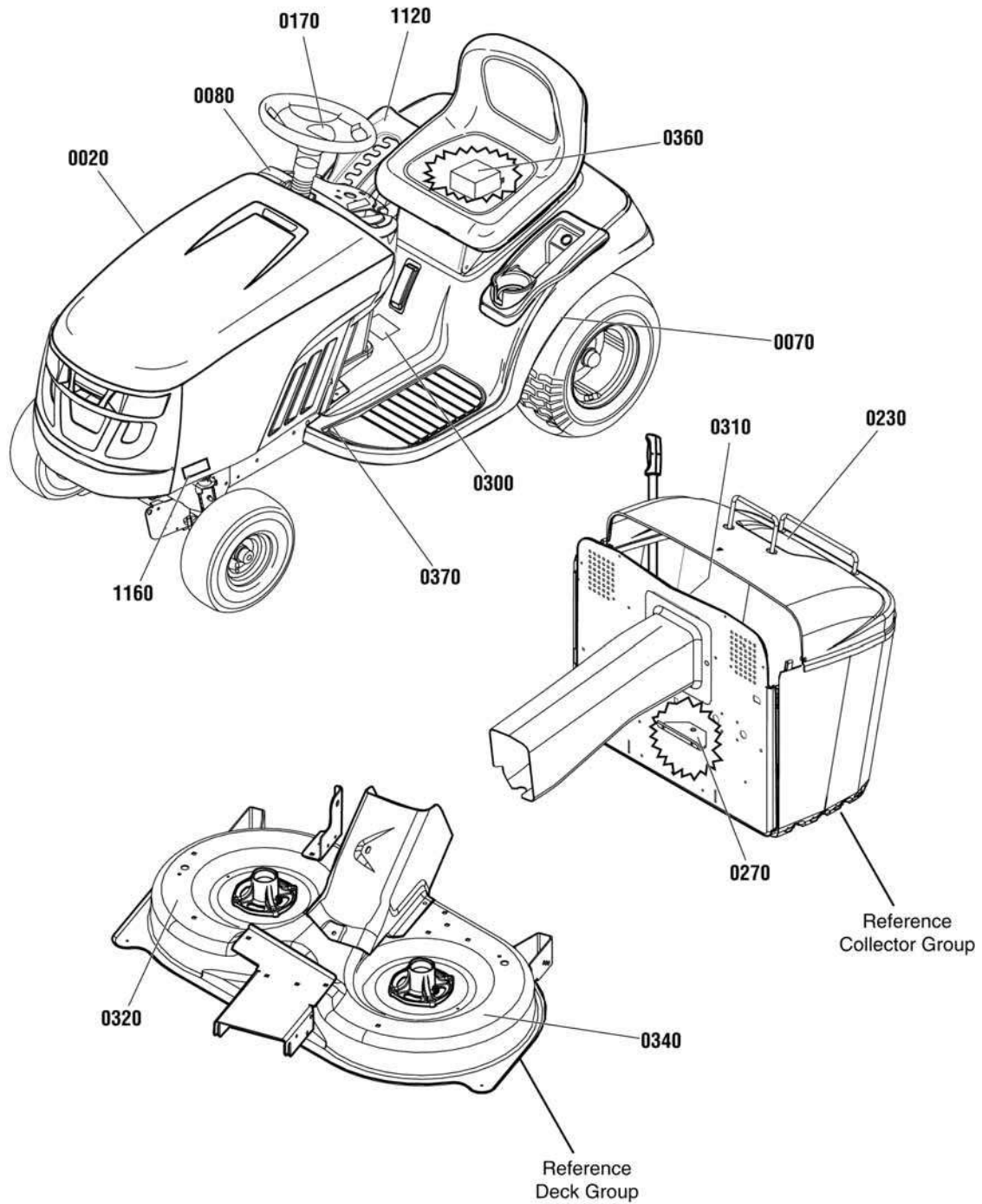

The above parts group applies to the following Mfg. Nos.:

1696109-00 - EMT17538RDF

1696110-00 - EMT18v38RDF



## Decal Group

REF NO	PART NO.	QTY.	DESCRIPTION
0020	1739087YP	1	DECAL, Murray
0070	7101935YP	1	DECAL, Roll Release
0080	885749YP	1	DECAL, Ignition Switch Symbols
0170	1737167YP	1	DECAL, Steering Wheel
0230	1739088YP	1	DECAL, Murray
0270	48X511MA	1	DECAL, Drawbar Warning Symbol
0300	1723175SM	1	DECAL, Tunnel
0310	1721107SM	1	DECAL, Discharge Tube Symbols
0320	1720389SM	1	DECAL, Danger Rotation Blade Symbols
0340	885624YP	1	DECAL, Cutting Width
0360	885816YP	1	DECAL, Battery
0370	48X736MA	1	DECAL, Clutch/Brake
1120	1730264SM	1	DECAL, Height of Cut
1160	885778YP	1	DECAL, Model, EMT17538RDF
1160	885781YP	1	DECAL, Model, EMT1838RDF

Not for  
Reproduction

## Footnotes

---

**The above parts group applies to the following Mfg. Nos.:**

1696109-00 - EMT17538RDF

1696110-00 - EMT18v38RDF

## Guard Group - 38" RD

885597

NOTE: Unless noted otherwise,  
use the standard hardware torque  
specification chart.

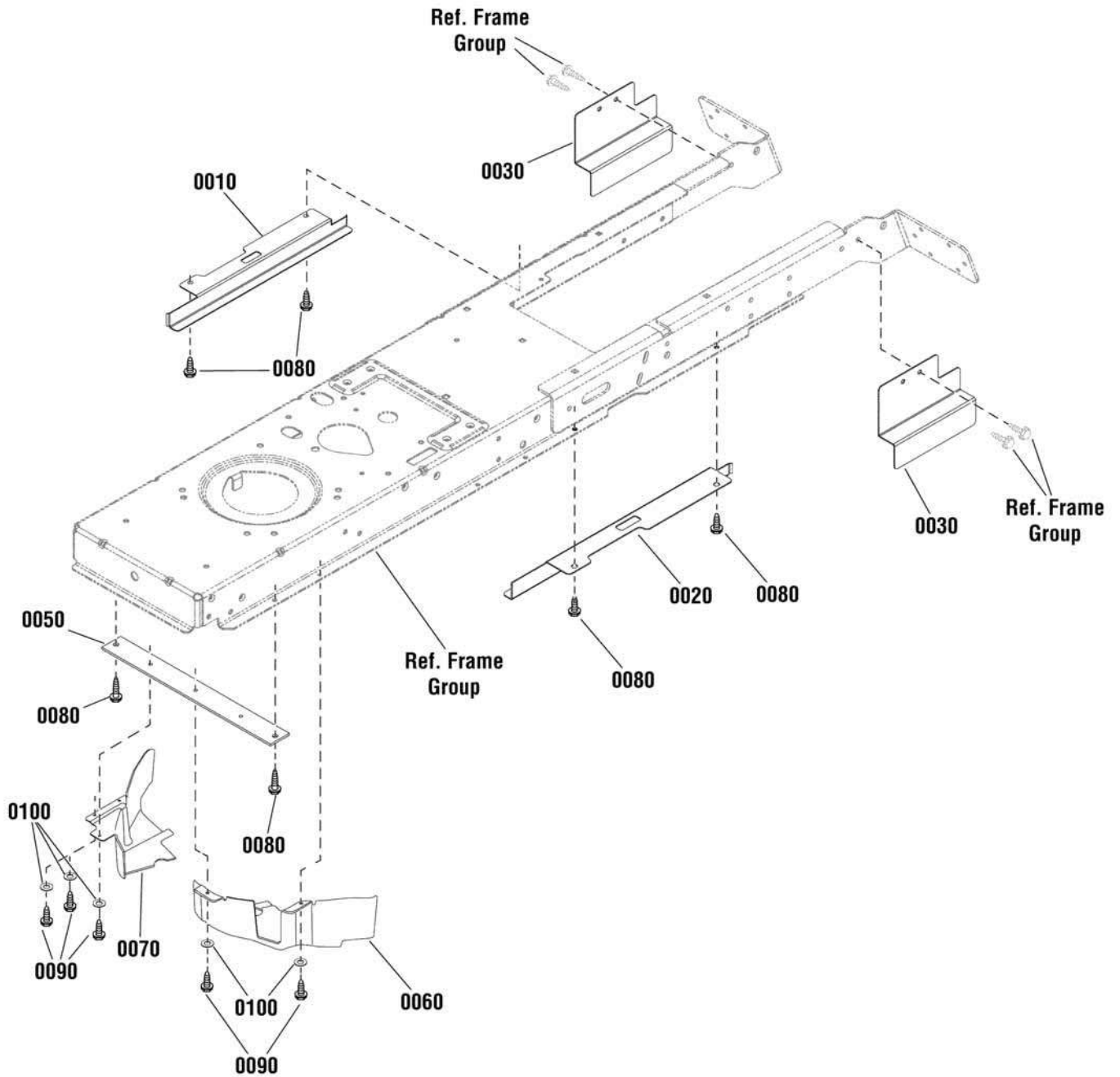

The above parts group applies to the following Mfg. Nos.:

1696109-00 - EMT17538RDF

1696110-00 - EMT18v38RDF

## Guard Group - 38" RD

REF NO	PART NO.	QTY.	DESCRIPTION
0010	885598AYP	1	GUARD, Middle Right
0020	885599AYP	1	GUARD, Middle Left
0030	885600AYP	2	GUARD, Rear
0050	885602AYP	1	BRACE, Guard
0060	885604YP	1	GUARD, Front, LH
0070	885605YP	1	GUARD, Front, RH
0080	1664847SM	6	CAPSCREW, Hex Washer Head, Taptite, 5/16-18 x 3/4
0090	1925003SM	5	CAPSCREW, Hex Washer Head, Taptite, 1/4-20 x 1/2
0100	2821319SM	5	WASHER, 1/4

Not for  
Reproduction

### Footnotes

---

**The above parts group applies to the following Mfg. Nos.:**

1696109-00 - EMT17538RDF

1696110-00 - EMT18v38RDF

## Collector Group

885708

NOTE: Unless noted otherwise,  
use the standard hardware torque  
specification chart.

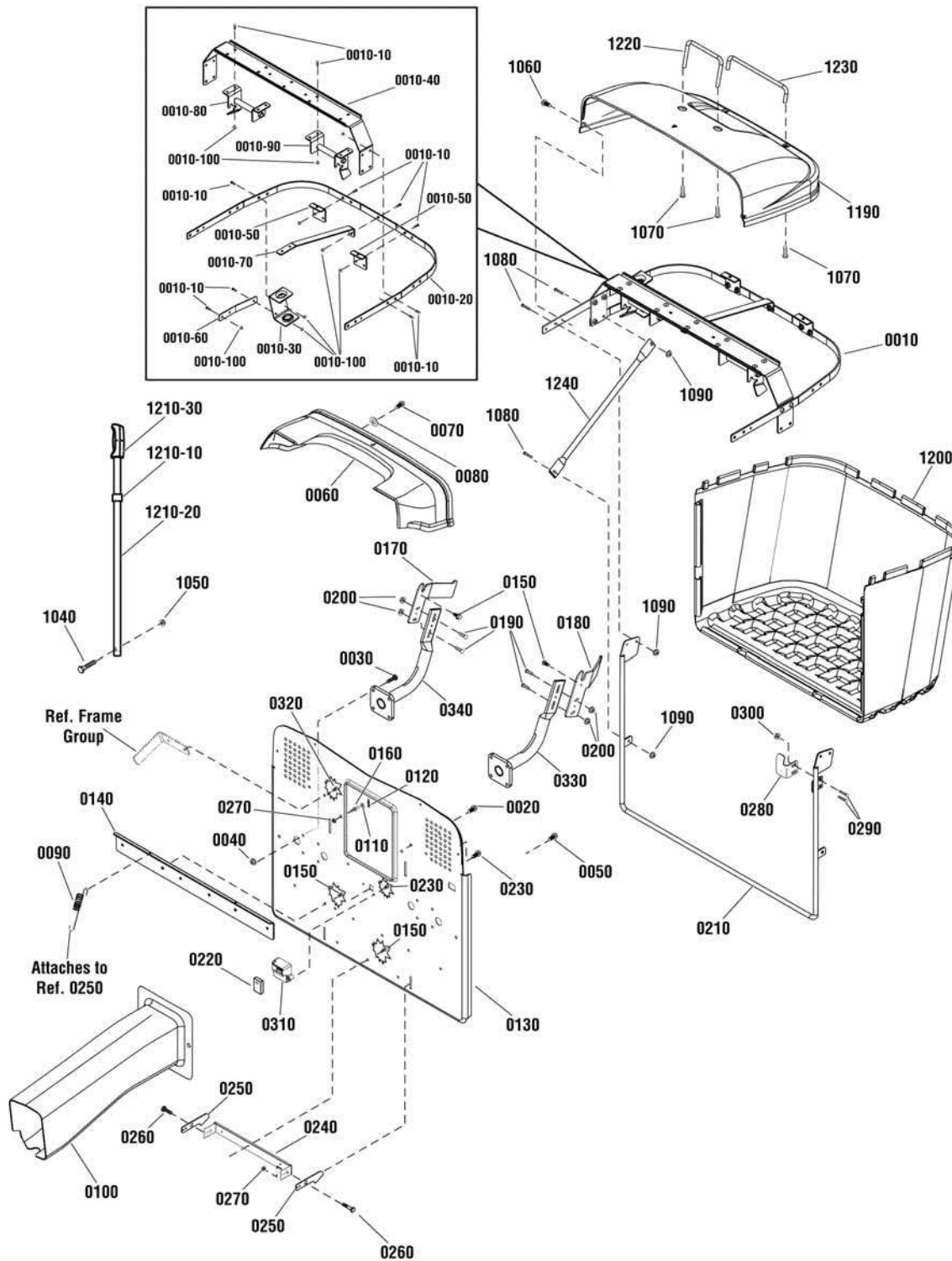

The above parts group applies to the following Mfg. Nos.:

1696109-00 - EMT17538RDF

1696110-00 - EMT18v38RDF

## Collector Group

REF NO	PART NO.	QTY.	DESCRIPTION
0010	885560YP	1	FRAME ASSEMBLY
0010-10	002X82MA	23	BOLT, Carriage, 1/4-20 X 5/8 (Included in Ref. 0010)
0010-20	885413AYP	1	FRAME, Upper (Included in Ref. 0010)
0010-30	885416AYP	1	SUPPORT, Dump Handle (Included in Ref. 0010)
0010-40	885507AYP	1	CROSS BRACE (Included in Ref. 0010)
0010-50	885514AYP	2	BRACKET, Mounting, Long (Included in Ref. 0010)
0010-60	885520AYP	1	SUPPORT STRAP, Dump Handle (Included in Ref. 0010)
0010-70	885525AYP	1	SUPPORT, Back, Frame (Included in Ref. 0010)
0010-80	885561AYP	1	BAGGER LOCATOR ASSEMBLY, LH (Included in Ref. 0010)
0010-90	885562AYP	1	BAGGER LOCATOR ASSEMBLY, RH (Included in Ref. 0010)
0010-100	1930641SM	23	NUT, Hex Flange, 1/4-20 (Included in Ref. 0010)
0020	1664847SM	4	CAPSCREW, Hex Washer Head, Taptite, 5/16-18 x 3/4
0030	1931202SM	8	CAPSCREW, Hex Washer Head, Taptite, 5/16-18 x 1-1/4
0040	015X79MA	10	NUT, Hex Flange, Serrated, 5/16-18
0050	1664847SM	2	CAPSCREW, Hex Washer Head, Taptite, 5/16-18 x 3/4
0060	885400YP	1	COVER, Transition
0070	1664847SM	4	CAPSCREW, Hex Washer Head, Taptite, 5/16-18 x 3/4
0080	1919326SM	4	WASHER, 5/16
0090	165X92MA	2	SPRING, Extension
0100	885461YP	1	CHUTE
0110	1960170SM	2	WASHER, 1/2
0120	1960074SM	2	CLIP, Hair Pin
0130	885651BMYP	1	BACK PLATE
0140	885470AYP	1	BRACE, Lower Back Plate
0150	1664847SM	7	CAPSCREW, Hex Washer Head, Taptite, 5/16-18 x 3/4
0160	094067MA	2	PIN, Threaded Shoulder
0170	885494AYP	1	PLATE, Rotation, RH
0180	885473AYP	1	PLATE, Rotation, LH
0190	1931333SM	4	BOLT, Carriage, Short Neck, 5/16-18 x 3/4, G5
0200	015X79MA	4	NUT, Hex Flange, Serrated, 5/16-18
0210	885566AYP	1	FRAME, Bagger
0220	885573YP	1	SWITCH, Bag Full
0230	880760YP	2	SCREW, Plastite, #10-14 x 7/8
0240	885497AYP	1	BRACKET, Bagger Latch
0250	885496AYP	2	LATCH, Bagger
0260	009X39MA	2	BOLT, Shoulder
0270	015X84MA	4	NUT, Hex Flange, Center Lock, 3/8-16
0280	885489AYP	1	PLATE, Switch
0290	002X82MA	2	BOLT, Carriage, 1/4-20 x 5/8
0300	1930641SM	2	NUT, Hex Flange, Whiz Lock, 1/4-20
0310	885618YP	1	COVER, Bag Full Switch
0320	26X249MA	4	CAPSCREW, 5/16-18 x 3/4
0330	885652BMYP	1	SUPPORT, Bagger, LH

### Footnotes

The above parts group applies to the following Mfg. Nos.:

1696109-00 - EMT17538RDF

1696110-00 - EMT18v38RDF



## Collector Group

REF NO	PART NO.	QTY.	DESCRIPTION
0340	885653BMYP	1	SUPPORT, Bagger, RH
1040	001X94MA	1	CAPSCREW, Hex Flange Lock, 1/4-20 x 1-1/4
1050	015X89MA	1	NUT, Hex Flange, Lock, 1/4-20
1060	885564YP	2	SCREW, Torx, 1/4-20
1070	7091016YP	4	SCREW, Hex Washer Head, Self Tap, 1/4-20 x 5/8
1080	1960593SM	8	BOLT, Carriage, 1/4-20 x 5/8
1090	1930641SM	8	NUT, Hex Flange, Whiz Lock, 1/4-20
1190	885403YP	1	COVER, Collector, Black
1200	885510YP	1	BAG, Collector
1210-10	885433YP	1	ADJUSTER, Bagger Handle
1210-20	885518AYP	1	HANDLE, Bagger
1210-30	1723359SM	1	GRIP, Lift Rod
1220	885425AYP	1	HANDLE, Front
1230	885430AYP	1	HANDLE, Back
1240	885429AYP	2	STIFFENER

Not for  
Reproduction

## Footnotes

---

**The above parts group applies to the following Mfg. Nos.:**

1696109-00 - EMT17538RDF

1696110-00 - EMT18v38RDF

## 38" Mower Deck - Support Group

NOTE: Unless noted otherwise,  
use the standard hardware torque  
specification chart.

885709c

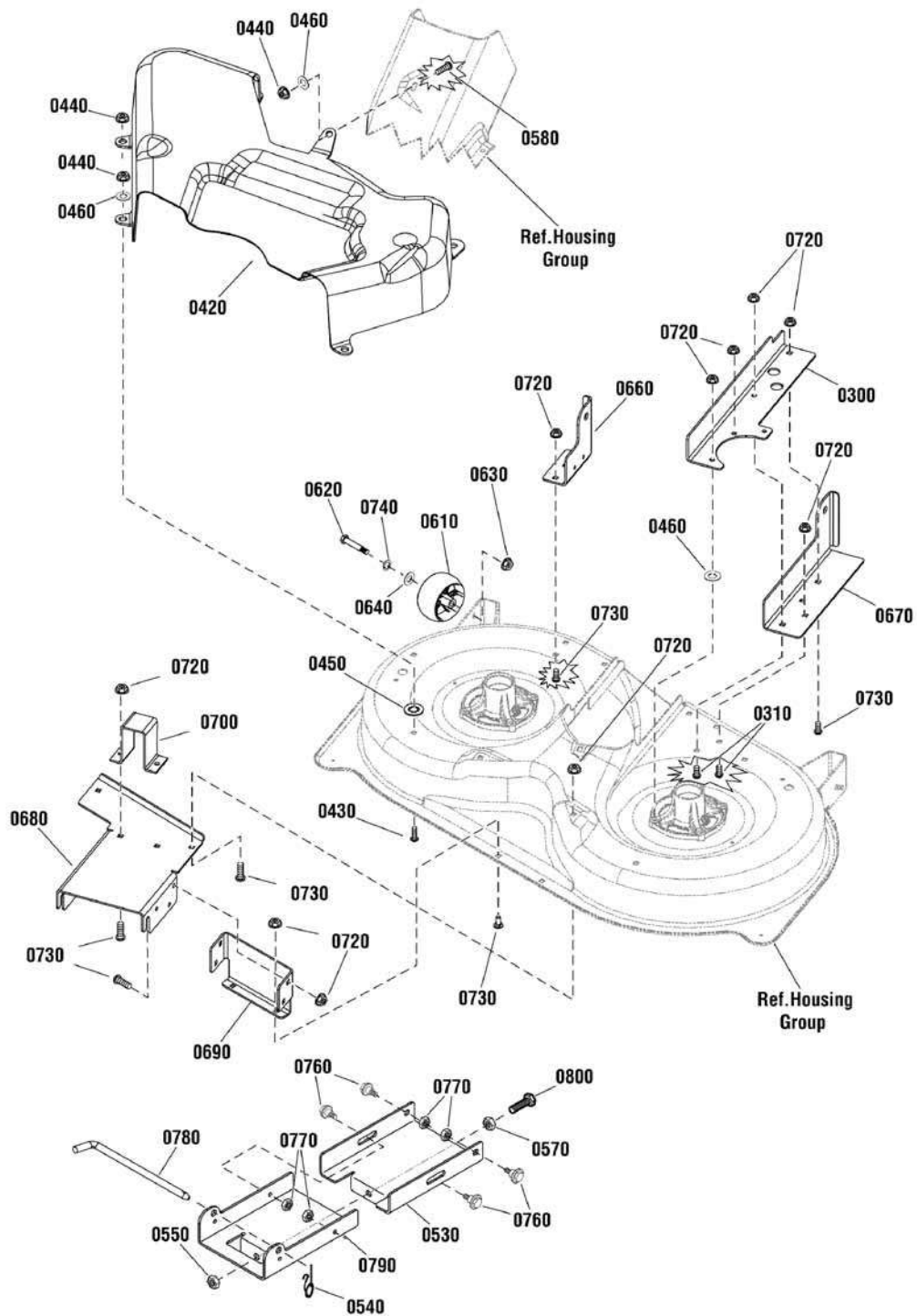

The above parts group applies to the following Mfg. Nos.:

1696109-00 - EMT17538RDF

1696110-00 - EMT18v38RDF



### 38" Mower Deck - Support Group

REF NO	PART NO.	QTY.	DESCRIPTION
0300	885526AYP	1	BRACKET, Rear Lift, LH
0310	1931333SM	2	BOLT, Carriage, Short Neck, 5/16-18 x 3/4, G5
0420	885543YP	1	COVER, Pulley
0430	1931333SM	5	BOLT, Carriage, Short Neck, 5/16-18 x 3/4, G5
0440	1931277SM	6	NUT, Hex Flange, Whiz Lock, 5/16-18
0450	5025498YP	6	NUT, Push On, 5/16
0460	1919326SM	6	WASHER, 5/16
0530	885734BMYP	1	BRACKET, Front Connector
0540	2176012SM	1	RETAINER, Pin Spring
0550	1960379SM	1	NUT, Hex Lock, ESNA LIGHT, 1/2-13
0570	1913744SM	1	NUT, Hex Jam, 1/2-13
0580	002X53MA	1	BOLT, Carriage, 5/16-18 x 5/8
0610	1714760SM	2	WHEEL, Gauge
0620	2108765SM	2	BOLT, 3/8-16 x 2-3/4
0630	1960687SM	2	NUT, Hex Flange, ESNA, 3/8-16
0640	1960170SM	2	WASHER, 1/2
0660	885462AYP	1	BRACKET, Deck, Rear
0670	885463AYP	1	BRACKET, Rear Lift, LH
0680	885738BMYP	1	SUPPORT, Deck Front
0690	885740BMYP	1	BRACKET, Front Support
0700	885519AYP	1	BRACKET, Front Upstop
0720	1931277SM	14	NUT, Hex Flange, Whiz Lock, 5/16-18
0730	1931333SM	14	BOLT, Carriage, Short Neck, 5/16-18 x 3/4, G5
0740	0020X3MA	2	WASHER, Spring, .30" ID
0760	1732426SM	4	BOLT, Shoulder, 5/16-18 x .13/16, 1/2" Thread Length
0770	1931277SM	4	NUT, Hex Flange, Whiz Lock, 5/16-18
0780	1731414SM	1	ROD, Latch
0790	885699BMYP	1	BRACKET, Front Hanger
0800	885710YP	1	BOLT, 1/2 x 3

#### Footnotes

The above parts group applies to the following Mfg. Nos.:

1696109-00 - EMT17538RDF

1696110-00 - EMT18v38RDF

## 38" Mower Deck - Clutch Group

NOTE: Unless noted otherwise,  
use the standard hardware torque  
specification chart.

885709b

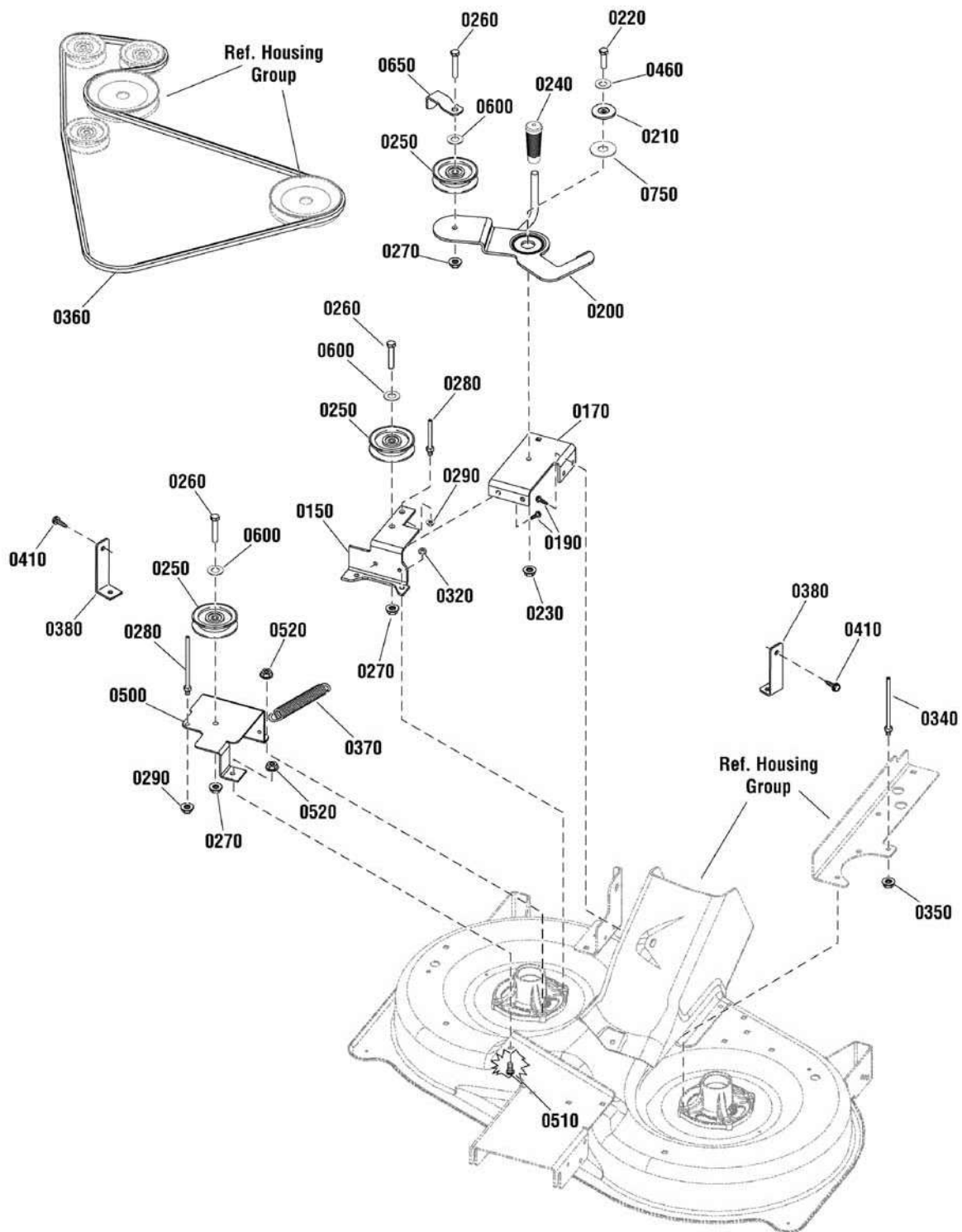

The above parts group applies to the following Mfg. Nos.:

1696109-00 - EMT17538RDF

1696110-00 - EMT18v38RDF

### 38" Mower Deck - Clutch Group

REF NO	PART NO.	QTY.	DESCRIPTION
0150	885481AYP	1	BRACKET, Idler, RH
0170	885516AYP	1	SUPPORT, Idler Arm
0190	1664847SM	4	CAPSCREW, Hex Washer Head, Taptite, 5/16-18 x 3/4
0200	885559AYP	1	DECK IDLER ASSEMBLY
0210	1727935SM	1	SPACER, Pivot, 0.330ID 1.76OD
0220	1921333SM	1	CAPSCREW, Hex Head, 5/16-18 x 1, G5
0230	015X88MA	1	NUT, Hex Flange, Center Lock, 5/16-18
0240	092697MA	1	GRIP
0250	885482YP	3	PULLEY, Deck Idler
0260	1923701SM	3	CAPSCREW, Hex Head, 3/8-16 x 2, G5
0270	1931211SM	3	NUT, Hex Flange, Whiz Lock, 3/8-16
0280	885534YP	2	BELT GUIDE
0290	1931277SM	2	NUT, Hex Flange, Whiz Lock, 5/16-18
0320	1931277SM	2	NUT, Hex Flange, Whiz Lock, 5/16-18
0340	1401105MA	1	BELT GUIDE, Long
0350	1931277SM	1	NUT, Hex Flange, Whiz Lock, 5/16-18
0360	885483YP	1	BELT, DECK (91.35" EL, HAA section)
0370	1715435SM	1	SPRING, Extension, 1
0380	885527AYP	2	UPSTOP
0410	1664847SM	4	CAPSCREW, Hex Washer Head, 5/16-18 x 3/4
0460	1919326SM	1	WASHER, 5/16
0500	885556AYP	1	BRACKET, Idler, Fixed
0510	1921333SM	1	CAPSCREW, Hex Head, 5/16-18 x 1, G5
0520	1931277SM	3	NUT, Hex Flange, Whiz Lock, 5/16-18
0600	1922755SM	3	WASHER, Flat, 3/8
0650	1677135ASM	1	GUARD, Spring
0750	885675YP	1	SHIM

#### Footnotes

The above parts group applies to the following Mfg. Nos.:

1696109-00 - EMT17538RDF

1696110-00 - EMT18v38RDF

## 38" Mower Deck - Housing, Arbors & Blade Group

NOTE: Unless noted otherwise,  
use the standard hardware torque  
specification chart.

885709a

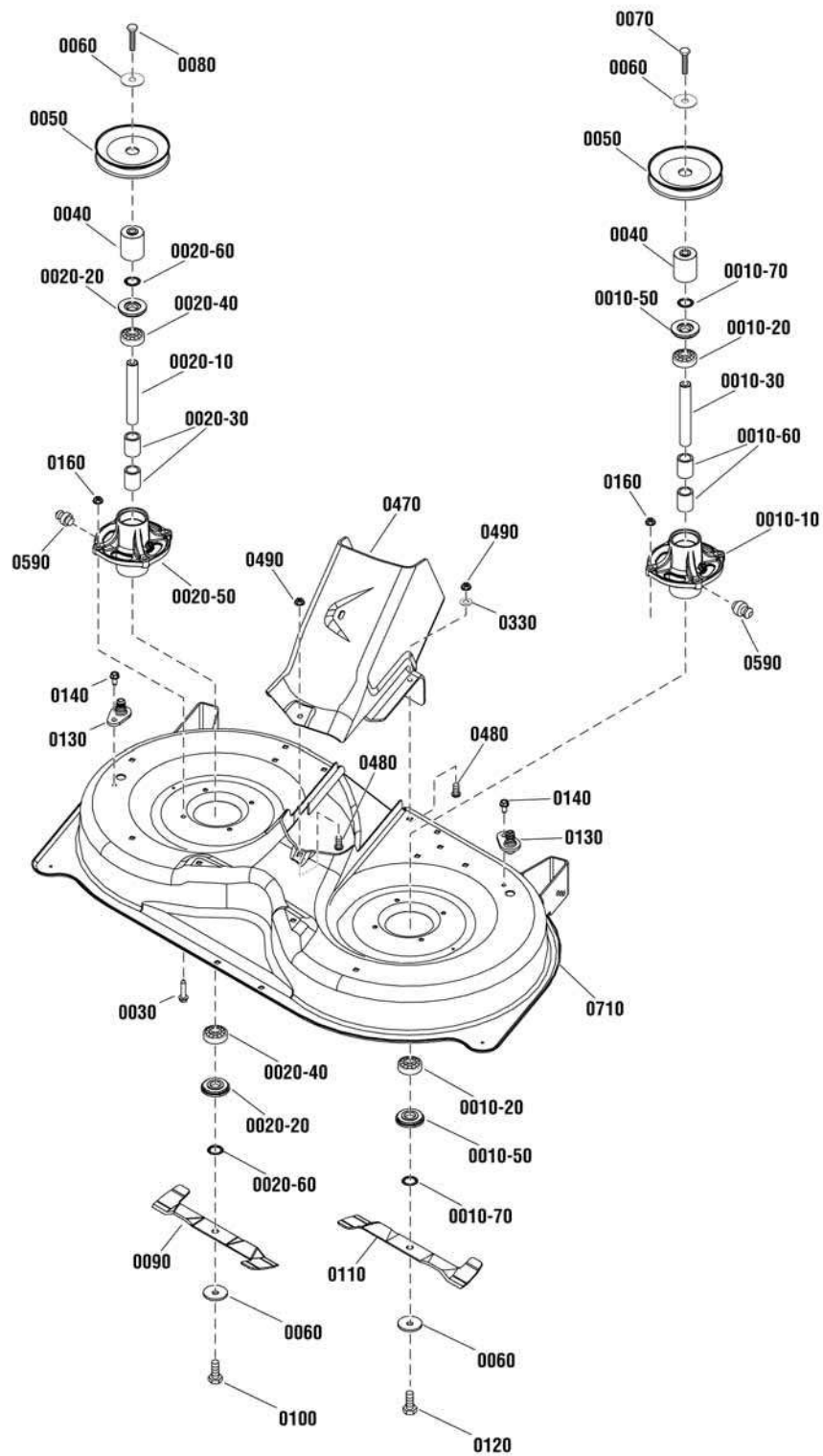

The above parts group applies to the following Mfg. Nos.:

1696109-00 - EMT17538RDF

1696110-00 - EMT18v38RDF

### 38" Mower Deck - Housing, Arbors & Blade Group

REF NO	PART NO.	QTY.	DESCRIPTION
0010-10	1735573YP	2	HOUSING, Spindle
0010-20	1735399YP	4	BEARING, Ball, 20mm
0010-30	1735326YP	1	SHAFT, Spindle, LH
0010-50	1735323YP	4	SHIELD, Arbor
0010-60	1735328YP	4	SPACER, Bearing
0010-70	1960766YP	4	RING, Self Locking
0020-10	885420YP	1	SHAFT, Spindle, RH (LH Thread)
0020-20	1735323YP	4	SHIELD, Arbor
0020-30	1735328YP	4	SPACER, Bearing
0020-40	1735399YP	4	BEARING, Ball, 20mm
0020-50	1735573YP	2	HOUSING, Spindle
0020-60	1960766YP	4	RING, Self Locking
0030	1930600SM	8	CAPSCREW, Hex Washer Head, Taptite, 5/16-18 x 1-1/2
0040	1750338YP	2	SPACER, Mower Drive
0050	1737835YP	2	PULLEY, Deep Groove
0060	1656916SM	4	WASHER, Spring, 0.475ID x 1-3/4 OD
0070	1926110SM	1	CAPSCREW, Hex Head, 7/16-14 x 2-3/4, G5
0080	885456YP	1	CAPSCREW, Socket Head, 7/16-14 x 2-3/4, LH
0090	885418BZYP	1	BLADE, RH, 19.5"
0100	885455YP	1	CAPSCREW, Socket Head, 7/16-14 x 1, LH
0110	885419BZYP	1	BLADE, LH, 19.5"
0120	1920676SM	1	CAPSCREW, Hex Head, 7/16-14 x 1, G5
0130	1735716YP	2	ADAPTER, Washout Port
0140	1664847SM	2	CAPSCREW, Hex Washer Head, Taptite, 5/16-18 x 3/4
0160	1931277SM	6	NUT, Hex Flange, Whiz Lock, 5/16-18
0330	1919326SM	3	WASHER, 5/16
0470	885460YP	1	DECK, CENTER CAP
0480	1931333SM	3	BOLT, Carriage, Short Neck, 5/16-18 x 3/4, G5
0490	1931277SM	3	NUT, Hex Flange, Whiz Lock, 5/16-18
0590	1704314SM	2	FITTING, Grease
0710	885557AYP	1	DECK ASSEMBLY

#### Footnotes

The above parts group applies to the following Mfg. Nos.:

1696109-00 - EMT17538RDF

1696110-00 - EMT18v38RDF

Not for  
Reproduction

# Hardware Identification & Torque Specifications

Torque Specification Chart								
FOR STANDARD METRIC MACHINE HARDWARE (Tolerance ± 20%)								
Property Class	5.6		8.8		10.9		12.9	
	Class 5.6		Class 8.8		Class 10.9		Class 12.9	
Size Of Hardware	in/lbs		in/lbs		in/lbs		in/lbs	
	ft/lbs	Nm.	ft/lbs	Nm.	ft/lbs	Nm.	ft/lbs	Nm.
M3	5.88	.56	13.44	1.28	19.2	1.80	22.92	2.15
M4	13.44	1.28	30.72	2.90	43.44	4.10	52.56	4.95
M5	26.4	2.50	60.96	5.75	5.97	8.10	7.15	9.7
M6	44.64	4.3	7.3	9.9	10.3	14	12.1	16.5
M7	5.2	7.1	12.1	16.5	16.9	23	19.9	27
M8	7.7	10.5	17.7	24	25	34	29	40
M10	15	21	35	48	50	67	59	81
M12	26	36	61	83	86.2	117	103	140
M14	42	58	101	132	136	185	162	220
M16	64	88	147	200	210	285	250	340
M18	89	121	202	275	287	390	346	470
M20	126	171	290	390	405	550	486	660
M22	169	230	390	530	559	745	656	890
M24	217	295	497	375	708	960	840	1140
M27	320	435	733	995	1032	1400	1239	1680
M30	435	590	995	1350	1401	1900	1681	2280
M33	590	800	1349	1830	1902	2580	2278	3090
M36	759	1030	1740	2360	2441	3310	2935	3980
M39	988	1340	2249	3050	3163	4290	3798	5150

The guides and ruler furnished below are designed to help you select the appropriate hardware.

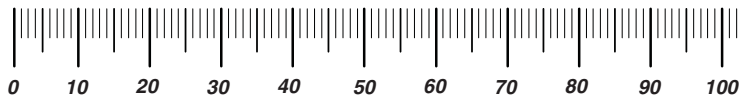

Nut, M8

Thread Diameter (mm)  
Inside Diameter (in)  
Threads per inch

Nut, 1/2-16

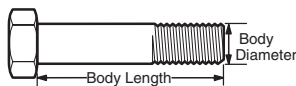

Screw, M8- 1.25 x 25

Thread Diameter (mm)  
Body Diameter  
Distance between threads (mm)  
Threads per inch  
Body Length (mm)  
Body Length (in)

Screw, 1/2- 16 x 2

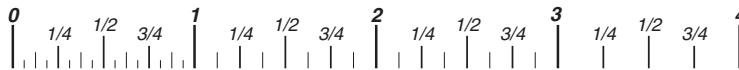

## Standard Hardware Sizing

When a washer or nut is identified as 1/2" (M8), this is the *Nominal size*, meaning the *inside diameter* is 1/2 inch (8mm metric thread diameter); if a second number is present it represents the *threads per inch* (distance between threads).

When bolt or capscrew is identified as 1/2 - 16 x 2" (M8 - 1.25 x 50 ), this means the *Nominal size*, or body diameter is 1/2 inch (8mm metric thread diameter), the second number, 16, represents the *threads per inch*, (1.25 thread diameter). The final number is the body length of the bolt or screw, 2 inches (50mm).

Torque Specification Chart						
FOR STANDARD MACHINE HARDWARE (Tolerance ± 20%)						
Hardware Grade	No Marks		SAE Grade 5		SAE Grade 8	
	SAE Grade 2		SAE Grade 5		SAE Grade 8	
Size Of Hardware	in/lbs		in/lbs		in/lbs	
	ft/lbs	Nm.	ft/lbs	Nm.	ft/lbs	Nm.
8-32	19	2.1	30	3.4	41	4.6
8-36	20	2.3	31	3.5	43	4.9
10-24	27	3.1	43	4.9	60	6.8
10-32	31	3.5	49	5.5	68	7.7
1/4-20	66	7.6	8	10.9	12	16.3
1/4-28	76	8.6	10	13.6	14	19.0
5/16-18	11	15.0	17	23.1	25	34.0
5/16-24	12	16.3	19	25.8	29	34.0
3/8-16	20	27.2	30	40.8	45	61.2
3/8-24	23	31.3	35	47.6	50	68.0
7/16-14	30	40.8	50	68.0	70	95.2
7/16-20	35	47.6	55	74.8	80	108.8
1/2-13	50	68.0	75	102.0	110	149.6
1/2-20	55	74.8	90	122.4	120	163.2
9/16-12	65	88.4	110	149.6	150	204.0
9/16-18	75	102.0	120	163.2	170	231.2
5/8-11	90	122.4	150	204.0	220	299.2
5/8-18	100	136	180	244.8	240	326.4
3/4-10	160	217.6	260	353.6	386	525.0
3/4-16	180	244.8	300	408.0	420	571.2
7/8-9	140	190.4	400	544.0	600	816.0
7/8-14	155	210.8	440	598.4	660	897.6
1-8	220	299.2	580	788.8	900	1,244.0
1-12	240	326.4	640	870.4	1,000	1,360.0

## NOTES

- These torque values are to be used for all hardware excluding: locknuts, self-tapping screws, thread forming screws, sheet metal screws and socket head setscrews.
- Recommended seating torque values for locknuts:
  - for prevailing torque locknuts - use 65% of grade 5 torques.
  - for flange whizlock nuts and screws - use 135% of grade 5 torques.
- Unless otherwise noted on assembly drawings, all torque values must meet this specification.

## Common Hardware Types

Hex Head Capscrew

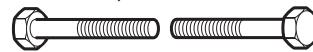

Washer



Lockwasher

Carriage Bolt

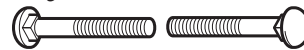

Hex Nut

## Wrench & Fastener Size Guide

1/4" Bolt or Nut Wrench—7/16"	5/16" Bolt or Nut Wrench—1/2"	3/8" Bolt or Nut Wrench—9/16"	7/16" Bolt or Nut Wrench (Bolt)—5/8" Wrench (Nut)—11/16"	1/2" Bolt or Nut Wrench—3/4"
M6 Bolt or Nut Wrench—10mm	M8 Bolt or Nut Wrench—13mm	M10 Bolt or Nut Wrench—17mm	M12 Bolt or Nut Wrench—19mm	M14 Bolt or Nut Wrench—22mm

Not for  
Reproduction

**IT IS THE POLICY OF BRIGGS & STRATTON CORP. TO IMPROVE ITS PRODUCTS  
WHENEVER IT IS POSSIBLE AND PRACTICAL TO DO SO. WE RESERVE THE RIGHT TO  
MAKE CHANGES OR ADD IMPROVEMENTS AT ANY TIME WITHOUT INCURRING ANY  
OBLIGATION TO MAKE SUCH CHANGES ON PRODUCTS.**

**Briggs & Stratton Power Products Group**

---

12301 W. Wirth Street  
Wauwatosa, WI, 53222 USA

[www.murray.com](http://www.murray.com)

© Copyright 2012 by Briggs & Stratton Corporation  
Milwaukee, WI, USA. All rights reserved