

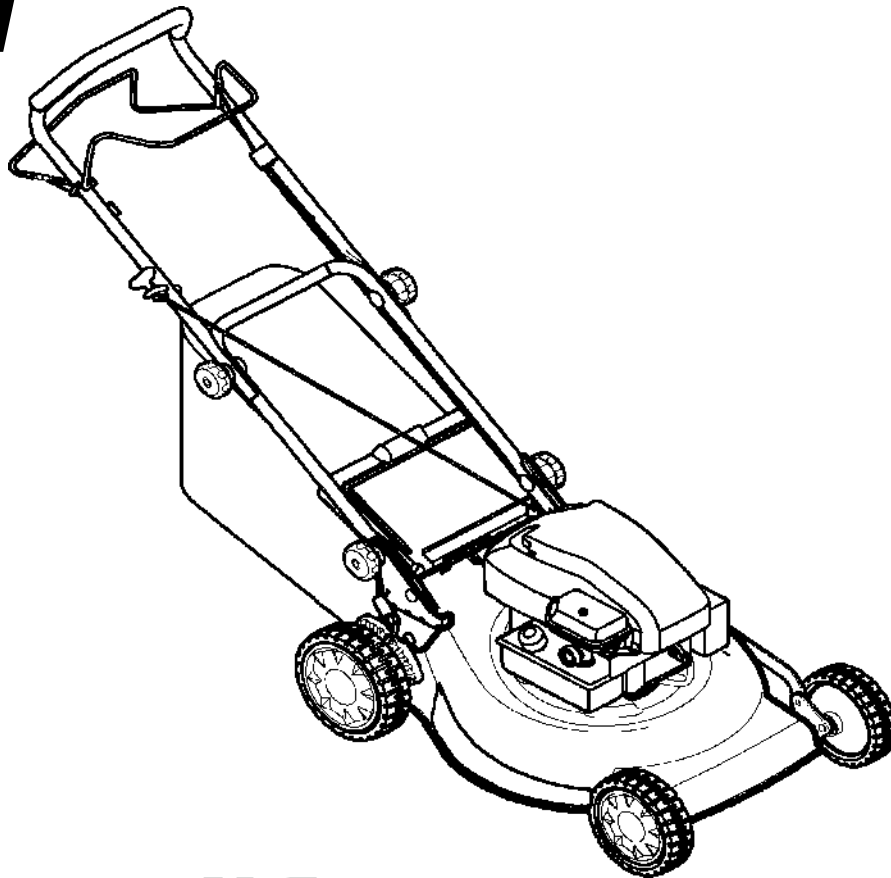

PARTS LIST



Models

Mfg. No.	Description
881028	MXTH675, 6.75TP 19" High Wheel Self-Propelled Mulching Mower, CE (2010)

Manual Part No. 881130
Revision C
Rev. Date: 4/8/2010

Not for
Reproduction

PRODUCT COMPONENTS	PAGES
Handle Assembly	4
Deck & Engine Group	6
Drive Group	10
Torque Specification Chart	Inside Back Cover

Not for
Reproduction

Handle Assembly

0003

NOTE: Unless noted otherwise,
use the standard hardware torque
specification chart.

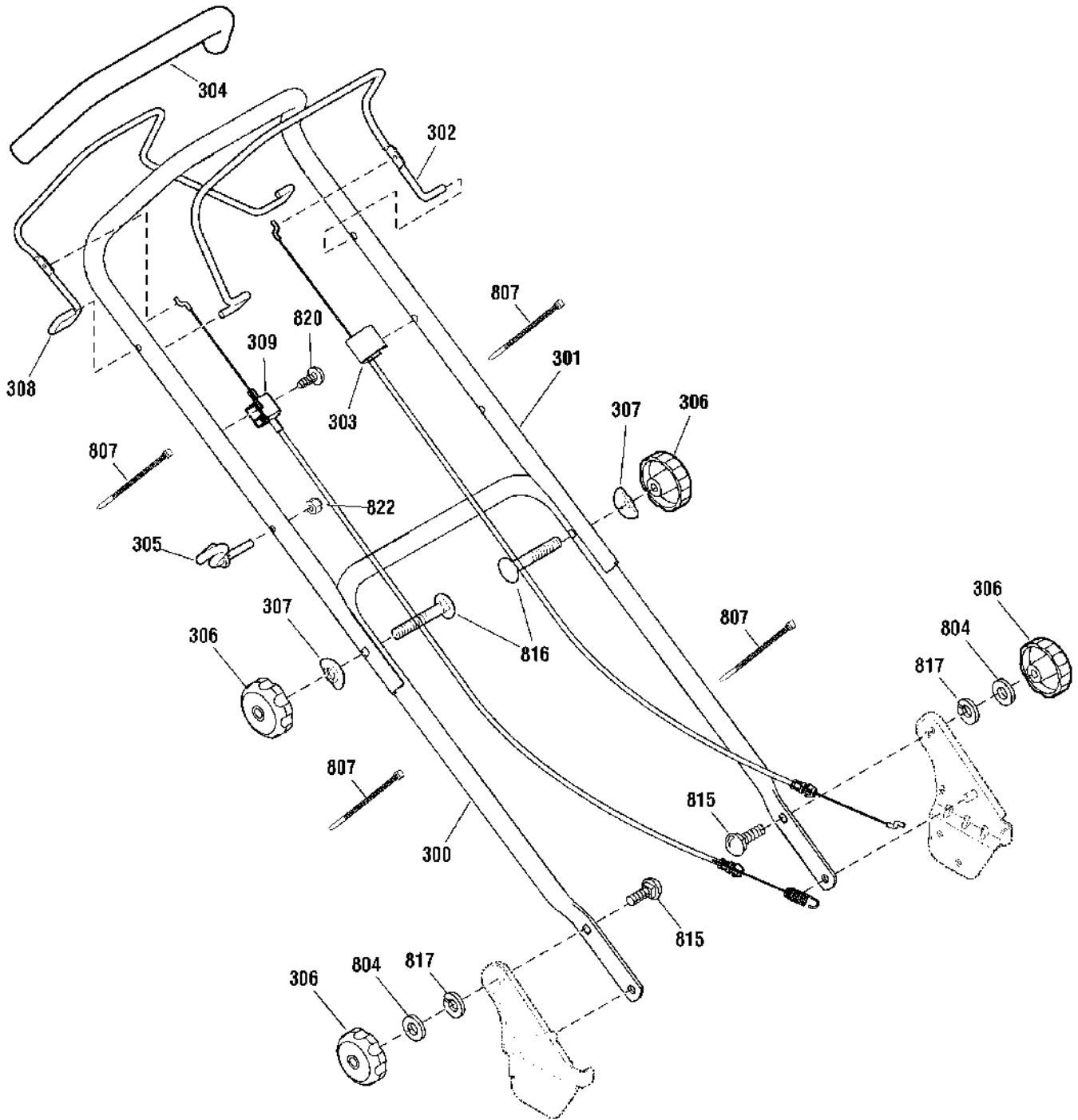

The above parts group applies to the following Mfg. Nos.:
881028 - MXTH675

Handle Assembly

REF NO	PART NO.	QTY.	DESCRIPTION
300	880571AYP	1	HANDLE, Lower
301	880210AYP	1	HANDLE, Upper
302	880476BNYP	1	LEVER, Engine Stop (Red)
302	880476ZYP	1	LEVER, Engine Stop (Black)
302	880476BIYP	1	LEVER, Engine Stop (Graphite)
303	880639YP	1	CABLE, Engine Stop
304	880591YP	1	TUBING, Foam
305	672510MA	1	GUIDE, Rope
306	881056YP	4	KNOB, 5/16-18 (Red)
306	881147YP	4	KNOB, 5/16-18 (Green)
307	880615YP	1	WASHER, Formed
308	881061BNYP	1	LEVER, Drive (Red)
308	881061ZYP	1	LEVER, Drive (Black)
308	881061BIYP	1	LEVER, Drive (Graphite)
309	880297YP	1	CABLE ASSEMBLY, Drive
804	880607YP	1	WASHER, 5/8
807	880029YP	1	CABLE TIE
815	880576YP	1	BOLT, Carriage, 5/16-18 x 1-1/8
816	002X77MA	1	BOLT, Carriage, 5/16-18 x 2
817	22129GS	1	WASHER, Lock
820	26X256MA	1	SCREW, Tap, #10 x 1-1/4
822	15X116MA	1	NUT, Hex, 1/4-20

Not for
Reproduction

Footnotes

The above parts group applies to the following Mfg. Nos.:

881028 - MXTH675

Deck & Engine Group

0001

NOTE: Unless noted otherwise,
use the standard hardware torque
specification chart.

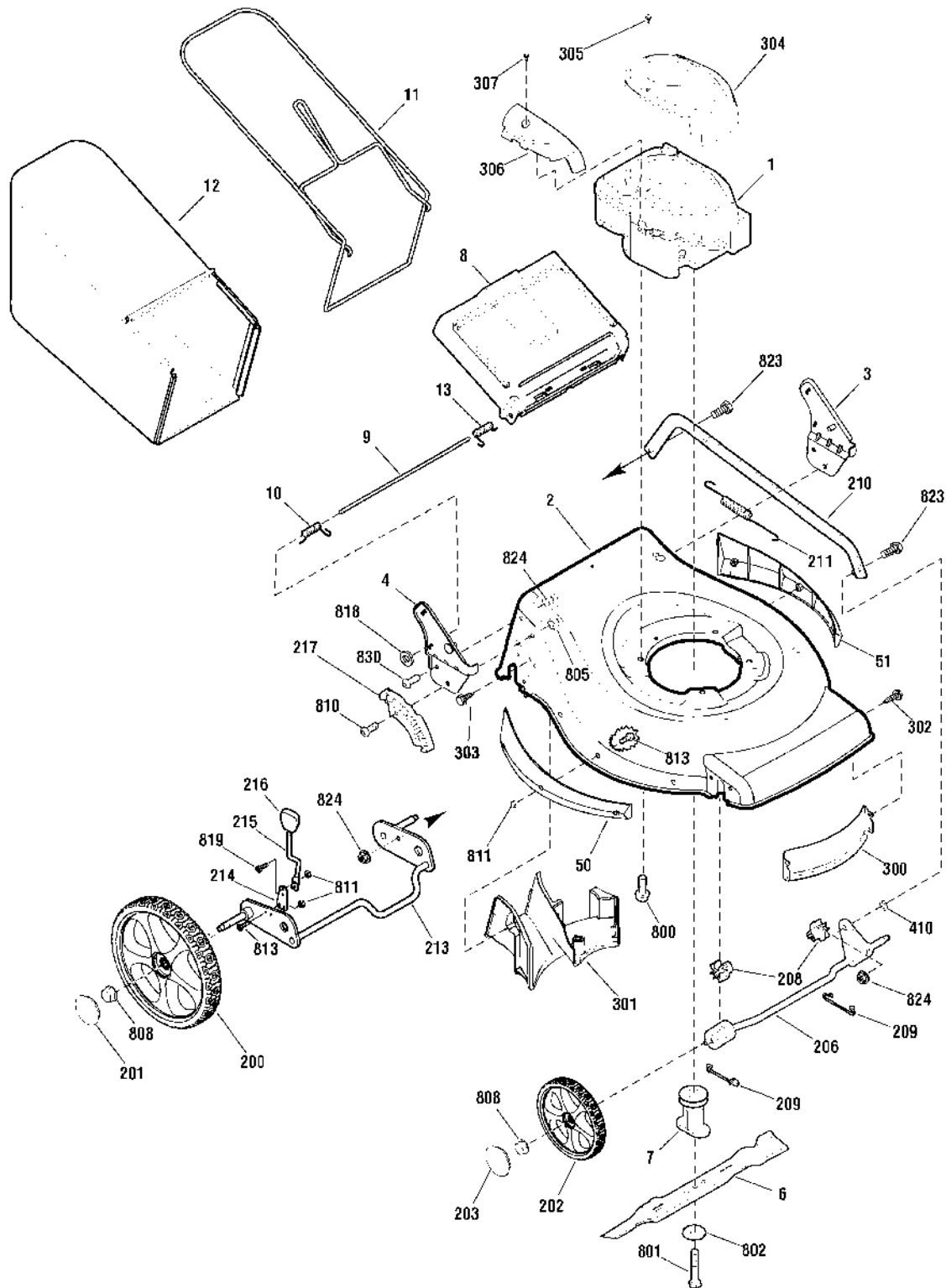

The above parts group applies to the following Mfg. Nos.:
881028 - MXTH675

Deck & Engine Group

REF NO	PART NO.	QTY.	DESCRIPTION
1	126T02-0276-B1	1	*ENGINE, 6.75GT Briggs & Stratton (Engine Model: 126T02-0276-B1)
2	881118BIYP	1	MOWER HOUSING (Includes Ref. Nos. 300 & 302)
3	880951AYP	1	BRACKET ASSEMBLY, Left Handle
4	880950AYP	1	BRACKET ASSEMBLY, Right Handle
6	880638YP	1	BLADE, 19 Inch
7	880567YP	1	BLADE ADAPTER ASSEMBLY
8	880671YP	1	DOOR, Rear
9	880214YP	1	ROD, Rear Door
10	880942YP	1	SPRING, Torsion Rear Door, Right
11	880941BNYP	1	FRAME ASSEMBLY (Red)
11	880941ZYP	1	FRAME ASSEMBLY (Black)
12	880909YP	1	BAG ASSEMBLY
13	880943YP	1	SPRING, Torsion Rear Door, Right
50	881108YP	1	SIDE GUARD, Right
51	881111YP	1	SIDE GUARD, Left
200	880695YP	1	WHEEL, Rear
201	880700YP	1	HUBCAP, Rear
202	880707YP	1	WHEEL, Front
203	880701YP	1	HUBCAP, Front
206	880550YP	1	CROSSBAR ASSEMBLY, Front
208	880050YP	1	BUSHING, Front Crossbar
209	881163YP	1	SPRING, Clip Crossbar
210	881174BIYP	1	LINK, Single Lever, High Wheel
211	880052YP	1	SPRING, Extension
213	880855BIYP	1	REAR CROSSBAR
214	880642YP	1	SPRING, Adjuster
215	880540YP	1	LEVER, Height Adjustment
216	881059YP	1	KNOB, Adjuster
217	880959YP	1	BRACKET, Height Adjuster
300	880784BIYP	1	BAFFLE, Front, 19
301	880785YP	1	BAFFLE, Rear, 19
302	880664YP	5	SCREW, Pan Head, Taptite, 1/4-20 x 1/2
303	880804YP	5	SCREW, Pan Head, Taptite, 1/4-15 x 5/8
304	795004YP	1	COVER, Static
305	691138	2	SCREW, Hex Washer Head
410	7026257MA	1	WASHER, Wave
800	0025X6MA	1	SCREW, Hex Head, 3/8-16 x 1
801	880034YP	1	BOLT, Blade, 3/8-24 x 2
802	1101989MA	1	WASHER, Belleville
805	880020YP	1	NUT, Nylock, M8 x 1-1/4
808	015X84MA	1	NUT, Flange, 3/8-16
810	880323YP	1	BOLT, Hex Key Head
811	880428YP	1	NUT, Nylock

Footnotes

NOTE: * Purchase engine parts from engine manufacturer dealer.

The above parts group applies to the following Mfg. Nos.:

881028 - MXTH675

Deck & Engine Group

0001

NOTE: Unless noted otherwise,
use the standard hardware torque
specification chart.

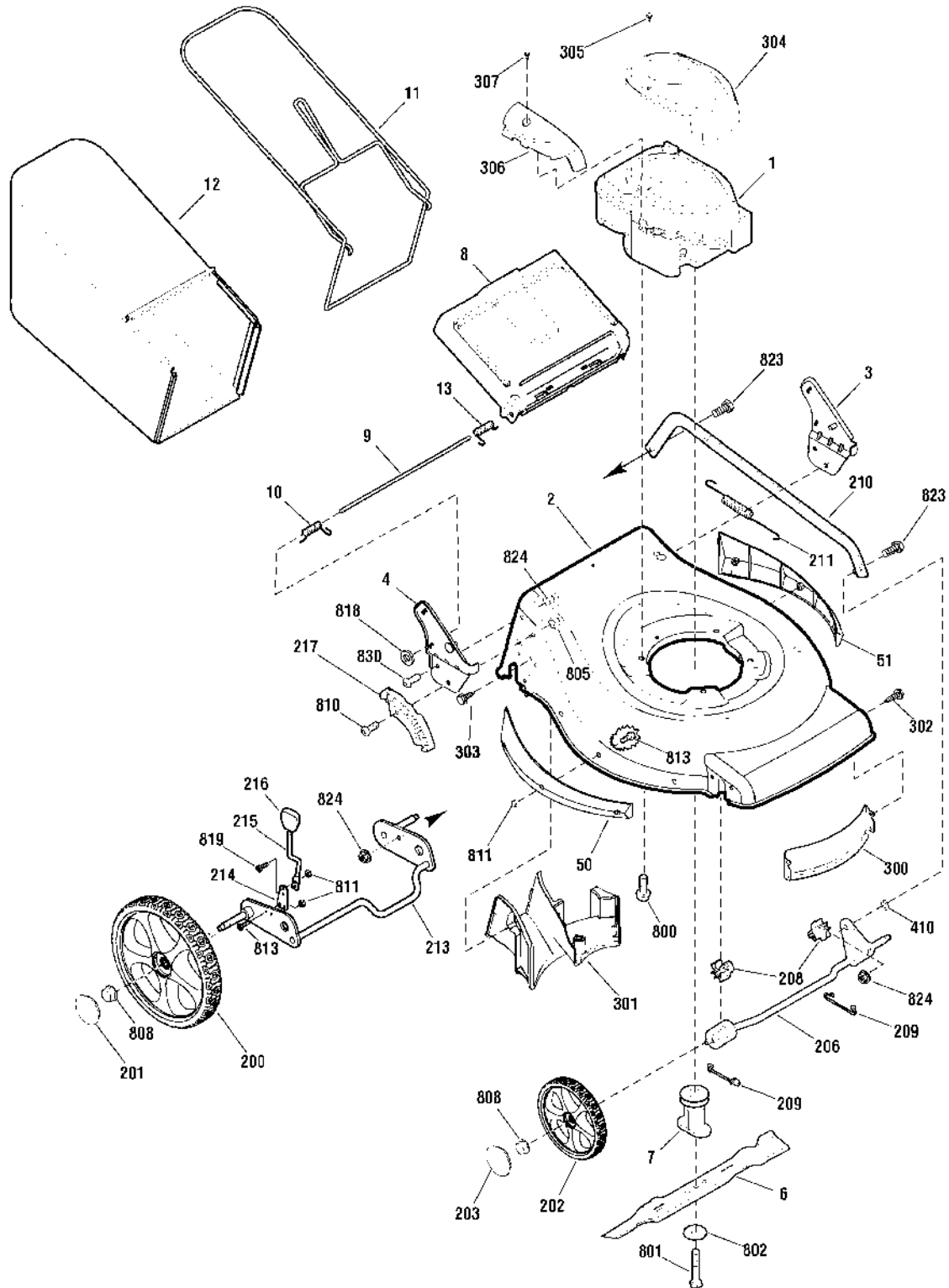

The above parts group applies to the following Mfg. Nos.:
881028 - MXTH675

Deck & Engine Group

REF NO	PART NO.	QTY.	DESCRIPTION
813	880339YP	1	SCREW, Torx Head, M5 x .8 x 14mm
818	7091020YP	2	PUSHNUT, 1/4
819	880577YP	1	SCREW, Torx Head, M5 x .8 x 12.5mm
823	880651YP	1	BOLT, Shoulder, 5/16-18 x 1
824	015X88MA	1	Nut, Flange, 5/16-18
830	48901MA	1	SCREW , 5/16-18 x 3/4
1000	700302YP	1	DECAL KIT

Not for
Reproduction

Footnotes

NOTE: * Purchase engine parts from engine manufacturer dealer.

The above parts group applies to the following Mfg. Nos.:

881028 - MXTH675

Drive Group

NOTE: Unless noted otherwise,
use the standard hardware torque
specification chart.

0002

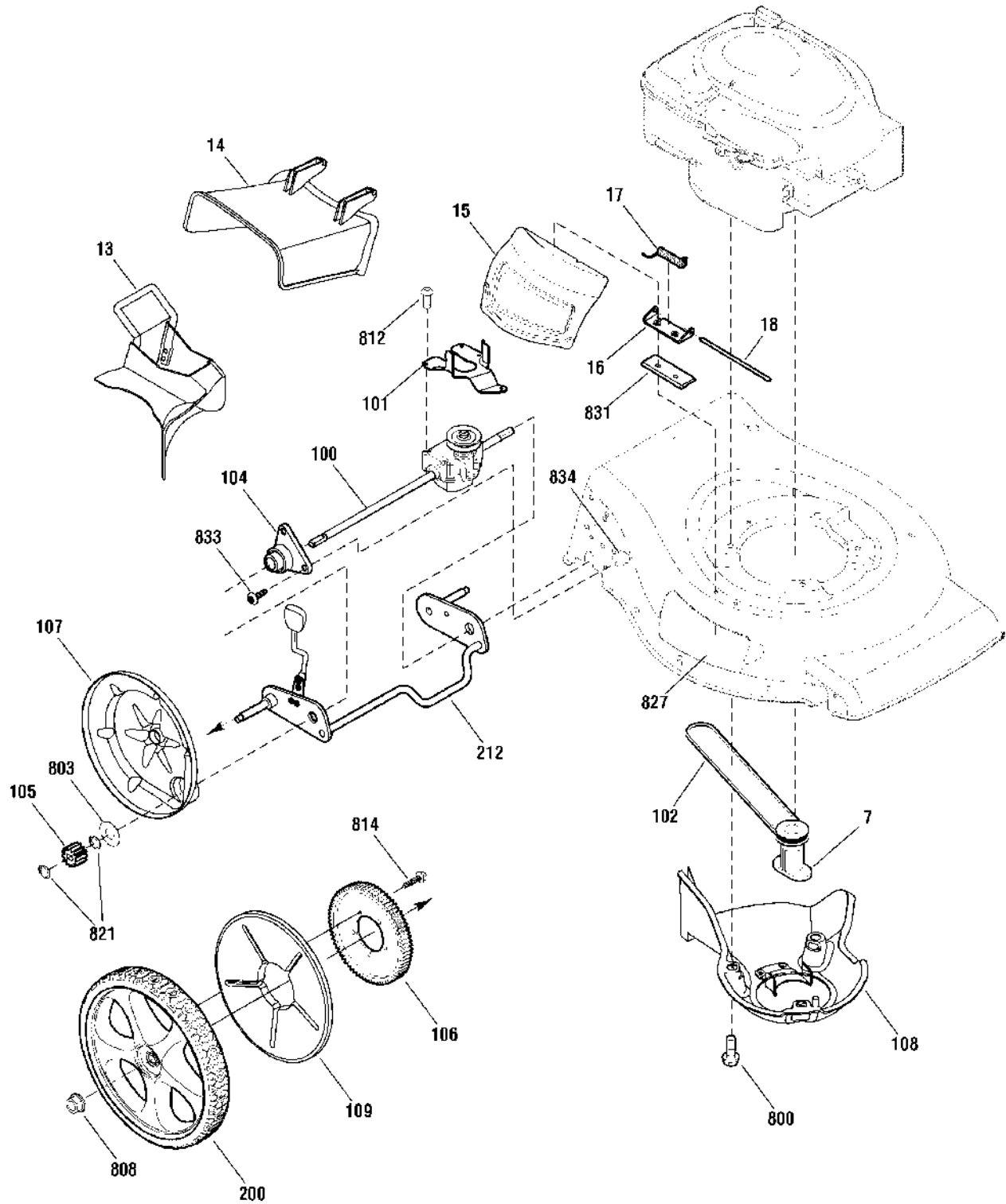

The above parts group applies to the following Mfg. Nos.:
881028 - MXTH675

Drive Group

REF NO	PART NO.	QTY.	DESCRIPTION
7	880567YP	1	BLADE ADAPTER ASSEMBLY
13	880909YP	1	MULCH PLUG
14	880803YP	1	CHUTE DEFLECTOR
15	880802YP	1	MULCH COVER
16	880584YP	1	BRACKET, Chute Deflector
17	880582YP	1	SPRING, Chute Deflector
18	880581YP	1	ROD, Chute Deflector
100	880604YP	1	TRANSMISSION
101	880282YP	1	BELT GUIDE, Transmission
102	880268YP	1	V-BELT
104	880787YP	1	SLEEVE ASSEMBLY, Rear Axle
105	880527YP	1	GEAR, Pinion
106	880526YP	1	GEAR, Drive
107	880528YP	1	DUST COVER
108	880796YP	1	BELT COVER ASSEMBLY
109	880539YP	1	COVER, Wheel
200	880695YP	1	WHEEL, Rear
212	880854YP	1	CROSSBAR ASSEMBLY, Rear
800	0025X6MA	1	SCREW, Hex Head, 3/8-16 x 1
808	015X84MA	1	NUT, Flange, 3/8-16
803	880324YP	1	WASHER, Thrust
812	880760YP	1	SCREW, #10 x 1
814	26X296MA	1	SCREW, 1/4-15 x 3/4
821	880269YP	1	RING, External Retaining
827	880664YP	1	SCREW, 1/4-20 x 7/8
831	880583YP	1	SPACER
833	880845YP	1	SCREW, Torx, 1/4-20 x 5/8
834	880859YP	1	NUT, Flange Lock, 1/4-20

Footnotes

The above parts group applies to the following Mfg. Nos.:

881028 - MXTH675

Not for
Reproduction

Not for
Reproduction

Not for
Reproduction

Hardware Identification & Torque Specifications

Torque Specification Chart								
FOR STANDARD METRIC MACHINE HARDWARE (Tolerance ± 20%)								
Property Class	5.6		8.8		10.9		12.9	
	Class 5.6		Class 8.8		Class 10.9		Class 12.9	
Size Of Hardware	in/lbs		in/lbs		in/lbs		in/lbs	
	ft/lbs	Nm.	ft/lbs	Nm.	ft/lbs	Nm.	ft/lbs	Nm.
M3	5.88	.56	13.44	1.28	19.2	1.80	22.92	2.15
M4	13.44	1.28	30.72	2.90	43.44	4.10	52.56	4.95
M5	26.4	2.50	60.96	5.75	5.97	8.10	7.15	9.7
M6	44.64	4.3	7.3	9.9	10.3	14	12.1	16.5
M7	5.2	7.1	12.1	16.5	16.9	23	19.9	27
M8	7.7	10.5	17.7	24	25	34	29	40
M10	15	21	35	48	50	67	59	81
M12	26	36	61	83	86.2	117	103	140
M14	42	58	101	132	136	185	162	220
M16	64	88	147	200	210	285	250	340
M18	89	121	202	275	287	390	346	470
M20	126	171	290	390	405	550	486	660
M22	169	230	390	530	559	745	656	890
M24	217	295	497	375	708	960	840	1140
M27	320	435	733	995	1032	1400	1239	1680
M30	435	590	995	1350	1401	1900	1681	2280
M33	590	800	1349	1830	1902	2580	2278	3090
M36	759	1030	1740	2360	2441	3310	2935	3980
M39	988	1340	2249	3050	3163	4290	3798	5150

The guides and ruler furnished below are designed to help you select the appropriate hardware.

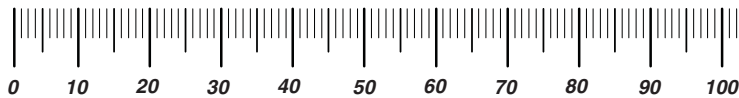

Nut, M8

Thread Diameter (mm)
Inside Diameter (in)
Threads per inch

Nut, 1/2-16

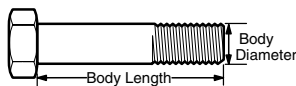

Screw, M8- 1.25 x 25

Thread Diameter (mm)
Body Diameter
Distance between threads (mm)
Threads per inch
Body Length (mm)
Body Length (in)

Screw, 1/2- 16 x 2

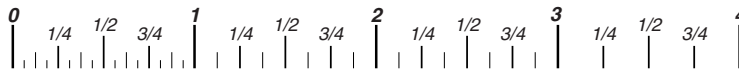

Standard Hardware Sizing

When a washer or nut is identified as 1/2" (M8), this is the *Nominal size*, meaning the *inside diameter* is 1/2 inch (8mm metric thread diameter); if a second number is present it represents the *threads per inch* (distance between threads).

When bolt or capscrew is identified as 1/2 - 16 x 2" (M8 - 1.25 x 50), this means the *Nominal size*, or body diameter is 1/2 inch (8mm metric thread diameter), the second number, 16, represents the *threads per inch*, (1.25 thread diameter). The final number is the body length of the bolt or screw, 2 inches (50mm).

Torque Specification Chart						
FOR STANDARD MACHINE HARDWARE (Tolerance ± 20%)						
Hardware Grade	No Marks		SAE Grade 5		SAE Grade 8	
	SAE Grade 2		SAE Grade 5		SAE Grade 8	
Size Of Hardware	in/lbs		in/lbs		in/lbs	
	ft/lbs	Nm.	ft/lbs	Nm.	ft/lbs	Nm.
8-32	19	2.1	30	3.4	41	4.6
8-36	20	2.3	31	3.5	43	4.9
10-24	27	3.1	43	4.9	60	6.8
10-32	31	3.5	49	5.5	68	7.7
1/4-20	66	7.6	8	10.9	12	16.3
1/4-28	76	8.6	10	13.6	14	19.0
5/16-18	11	15.0	17	23.1	25	34.0
5/16-24	12	16.3	19	25.8	29	34.0
3/8-16	20	27.2	30	40.8	45	61.2
3/8-24	23	31.3	35	47.6	50	68.0
7/16-14	30	40.8	50	68.0	70	95.2
7/16-20	35	47.6	55	74.8	80	108.8
1/2-13	50	68.0	75	102.0	110	149.6
1/2-20	55	74.8	90	122.4	120	163.2
9/16-12	65	88.4	110	149.6	150	204.0
9/16-18	75	102.0	120	163.2	170	231.2
5/8-11	90	122.4	150	204.0	220	299.2
5/8-18	100	136	180	244.8	240	326.4
3/4-10	160	217.6	260	353.6	386	525.0
3/4-16	180	244.8	300	408.0	420	571.2
7/8-9	140	190.4	400	544.0	600	816.0
7/8-14	155	210.8	440	598.4	660	897.6
1-8	220	299.2	580	788.8	900	1,244.0
1-12	240	326.4	640	870.4	1,000	1,360.0

NOTES

- These torque values are to be used for all hardware excluding: locknuts, self-tapping screws, thread forming screws, sheet metal screws and socket head setscrews.
- Recommended seating torque values for locknuts:
 - for prevailing torque locknuts - use 65% of grade 5 torques.
 - for flange whizlock nuts and screws - use 135% of grade 5 torques.
- Unless otherwise noted on assembly drawings, all torque values must meet this specification.

Common Hardware Types

Hex Head Capscrew



Washer



Lockwasher

Carriage Bolt



Hex Nut

Wrench & Fastener Size Guide

1/4" Bolt or Nut Wrench—7/16"	5/16" Bolt or Nut Wrench—1/2"	3/8" Bolt or Nut Wrench—9/16"	7/16" Bolt or Nut Wrench (Bolt)—5/8" Wrench (Nut)—11/16"	1/2" Bolt or Nut Wrench—3/4"
M6 Bolt or Nut Wrench—10mm	M8 Bolt or Nut Wrench—13mm	M10 Bolt or Nut Wrench—17mm	M12 Bolt or Nut Wrench—19mm	M14 Bolt or Nut Wrench—22mm

Not for
Reproduction

**IT IS THE POLICY OF BRIGGS & STRATTON CORP. TO IMPROVE ITS PRODUCTS
WHENEVER IT IS POSSIBLE AND PRACTICAL TO DO SO. WE RESERVE THE RIGHT TO
MAKE CHANGES OR ADD IMPROVEMENTS AT ANY TIME WITHOUT INCURRING ANY
OBLIGATION TO MAKE SUCH CHANGES ON PRODUCTS.**

Briggs & Stratton Yard Power Products Group

3515 N. 124 Street / PO Box 702
Wauwatosa, WI 53222 USA

www.murray.com

© Copyright 2010 by Briggs & Stratton Corporation
Milwaukee, WI, USA. All rights reserved