

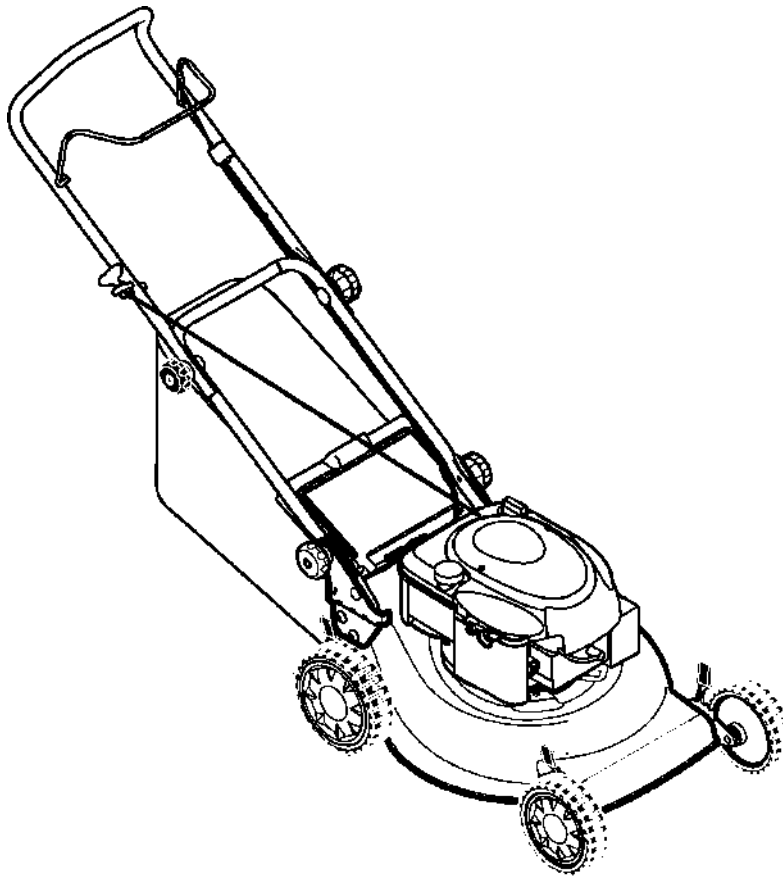

PARTS LIST



Models

Mfg. No.	Description
881020	MP450, 4.5GT 16" Walk Behind, CE (2010)

Manual Part No. 881122

Revision B

Rev. Date: 11/20/2009

Not for
Reproduction

PRODUCT COMPONENTS	PAGES
Handle Assembly	4
Deck & Engine Group	6
Torque Specification Chart	Inside Back Cover

Not for
Reproduction

Handle Assembly

NOTE: Unless noted otherwise,
use the standard hardware torque
specification chart.

0002

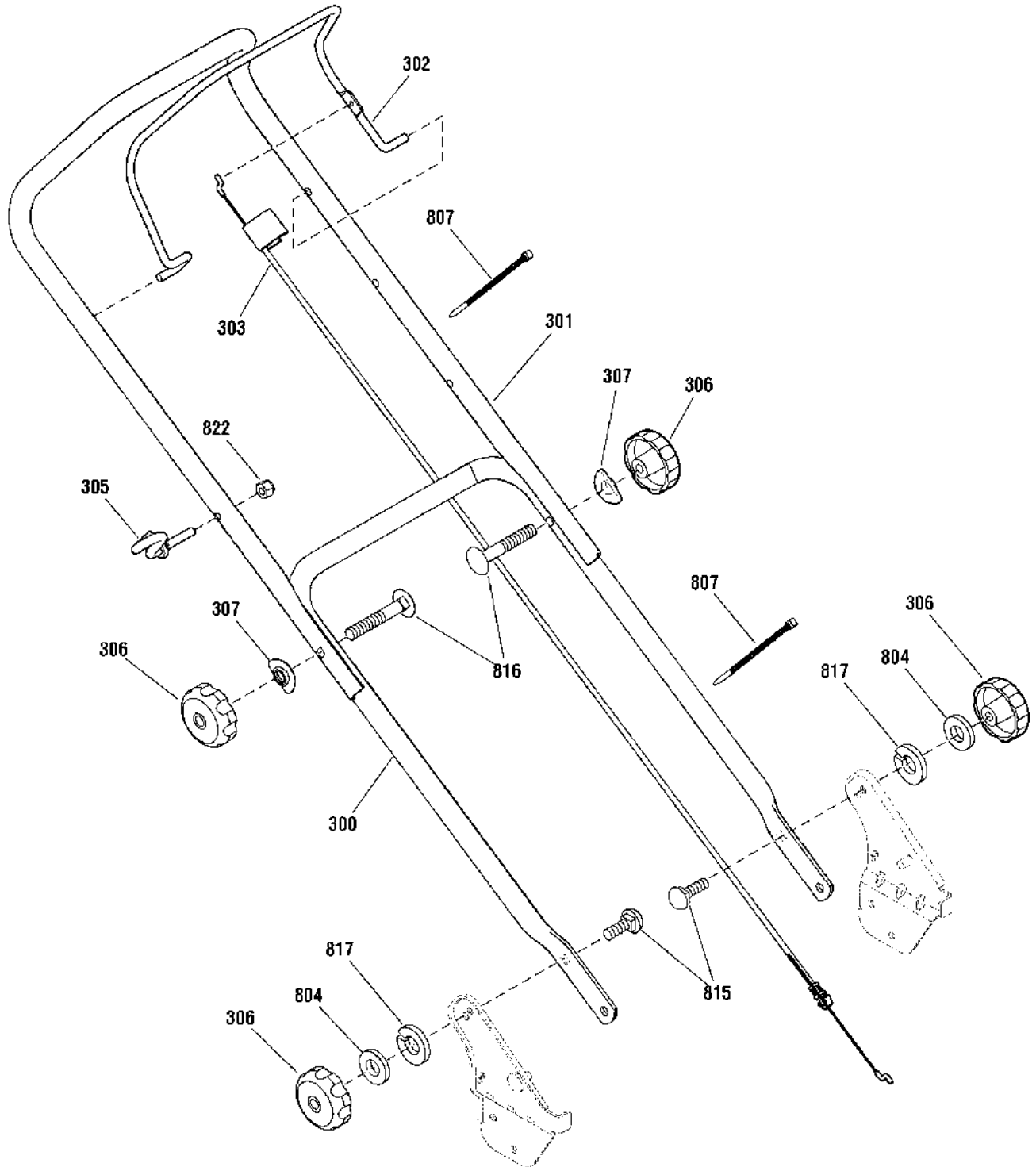

The above parts group applies to the following Mfg. Nos.:
881020 - MP450

Handle Assembly

REF NO	PART NO.	QTY.	DESCRIPTION
300	880608AYP	1	HANDLE, Lower
301	880470AYP	1	HANDLE, Upper
302	880637BNYP	1	LEVER, Engine Stop (Red)
302	880637ZYP	1	LEVER, Engine Stop (Black)
303	880279YP	1	CABLE, Engine Stop
305	672510MA	1	GUIDE, Rope, 1/4-20
307	880615YP	1	WASHER, Formed
306	881056YP	4	KNOB, 5/16-18
804	880607YP	1	WASHER, 5/8
807	880029YP	1	CABLE TIE
815	880576YP	1	BOLT, Carriage, 5/16-18 x 1-1/8
816	002X77MA	1	BOLT, Carriage, 5/16-18 x 2
817	22129GS	1	Washer, Lock
822	15X116MA	1	NUT, Hex, 1/4-20

Not for
Reproduction

Footnotes

The above parts group applies to the following Mfg. Nos.:

881020 - MP450

Deck & Engine Group

0001

NOTE: Unless noted otherwise,
use the standard hardware torque
specification chart.

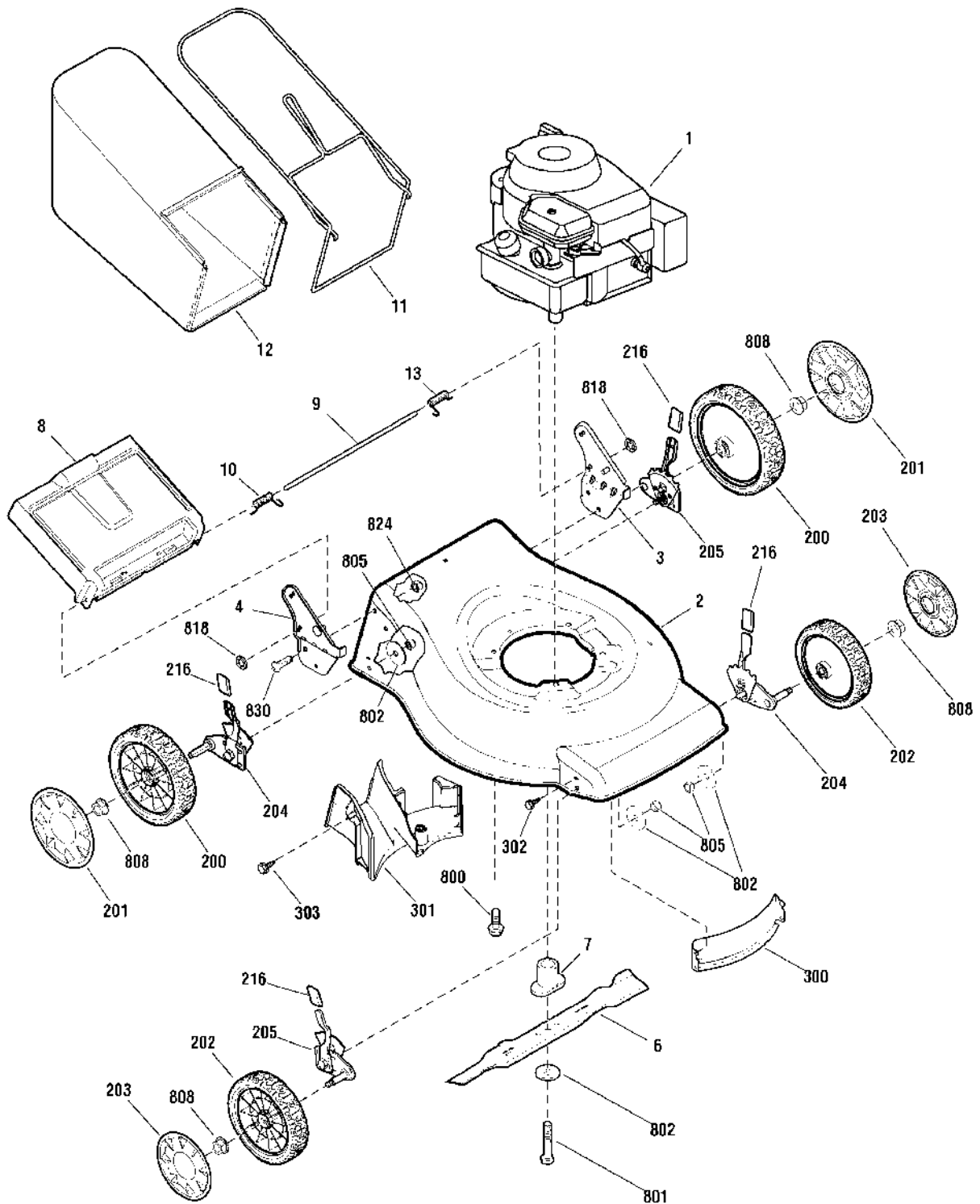

The above parts group applies to the following Mfg. Nos.:
881020 - MP450

Deck & Engine Group

REF NO	PART NO.	QTY.	DESCRIPTION
1	09T502-0130-B1	1	*ENGINE, 4.5GT Briggs & Stratton (Engine Model: 09T502-0130-B1)
2	881119BIYP	1	MOWER HOUSING (Includes Ref. Nos. 300 & 302)
3	880951AYP	1	BRACKET ASSEMBLY, Left Handle
4	880950AYP	1	BRACKET ASSEMBLY, Right Handle
6	881076YP	1	BLADE, 16 in
7	880009YP	1	BLADE ADAPTER ASSEMBLY
8	880661YP	1	DOOR, Rear
9	880213YP	1	ROD, Rear Door
10	880942YP	1	SPRING, Torsion Rear Door, Right
11	880944BNYP	1	FRAME ASSEMBLY (Red)
11	880944ZYP	1	FRAME ASSEMBLY (Black)
12	880947YP	1	BAG ASSEMBLY
13	880943YP	1	SPRING, Torsion Rear Door, Left
200	880703YP	1	WHEEL, Rear
201	880698YP	1	HUBCAP, Rear
202	880702YP	1	WHEEL, Front
203	880697YP	1	HUBCAP, Front
204	880106YP	1	HEIGHT ADJUSTER ASSEMBLY, Left
205	880115YP	1	HEIGHT ADJUSTER ASSEMBLY, Right
216	880542YP	4	GRIP, Height Adjustment
300	880794BIYP	1	BAFFLE, Front, 16
301	880793YP	1	BAFFLE, Rear, 16
302	880664YP	5	SCREW, Pan Head, Taptite, 1/4-20 x 1/2
303	880804YP	5	SCREW, Pan Head, Taptite, 1/4-15 x 5/8
800	0025X6MA	1	SCREW, Hex Head, 3/8-16 x 1
801	880034YP	1	BOLT, Blade, 3/8-24 x 2
802	1101989MA	1	WASHER, Belleville
805	880020YP	1	NUT, Nylock, M8 x 1-1/4
808	015X84MA	1	NUT, Flange, 3/8-16
809	26X245MA	1	SCREW, Self Tap, #10-16 x 1/2
818	7091020YP	1	PUSHNUT, 1/4
824	015X88MA	1	Nut, Flange, 5/16-18
830	48901MA	1	SCREW, 5/16-18 x 3/4
1000	700267YP	1	DECAL KIT

Footnotes

NOTE: * Purchase engine parts from engine manufacturer dealer.

The above parts group applies to the following Mfg. Nos.:

881020 - MP450

Not for
Reproduction

Not for
Reproduction

Not for
Reproduction

Hardware Identification & Torque Specifications

Common Hardware Types

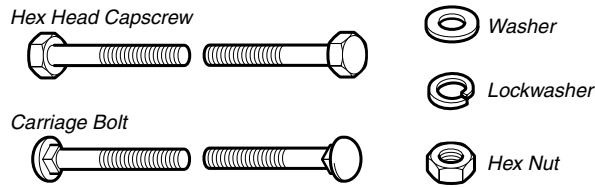

Standard Hardware Sizing

When a washer or nut is identified as 1/2", this is the *Nominal size*, meaning the *inside diameter* is 1/2 inch; if a second number is present it represents the *threads per inch*

When bolt or capscrew is identified as 1/2 - 16 x 2", this means the *Nominal size*, or *body diameter* is 1/2 inch; the second number represents the *threads per inch* (16 in this example, and the final number is the *body length* of the bolt or screw (in this example 2 inches long).

The guides and ruler furnished below are designed to help you select the appropriate hardware and tools.

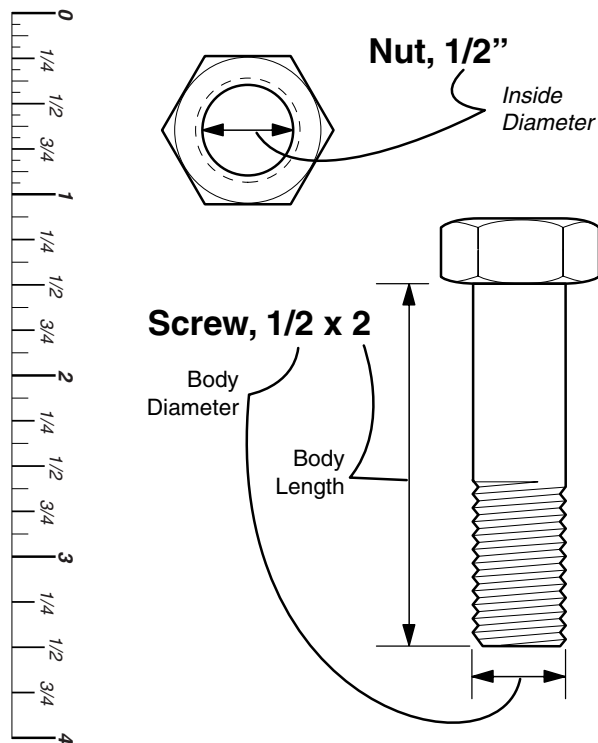

Torque Specification Chart

FOR STANDARD MACHINE HARDWARE (Tolerance $\pm 20\%$)

Hardware Grade	No Marks SAE Grade 2		SAE Grade 5		SAE Grade 8	
	in/lbs ft/lbs	Nm.	in/lbs ft/lbs	Nm.	in/lbs ft/lbs	Nm.
8-32	19	2.1	30	3.4	41	4.6
8-36	20	2.3	31	3.5	43	4.9
10-24	27	3.1	43	4.9	60	6.8
10-32	31	3.5	49	5.5	68	7.7
1/4-20	66	7.6	8	10.9	12	16.3
1/4-28	76	8.6	10	13.6	14	19.0
5/16-18	11	15.0	17	23.1	25	34.0
5/16-24	12	16.3	19	25.8	27	34.0
3/8-16	20	27.2	30	40.8	45	61.2
3/8-24	23	31.3	35	47.6	50	68.0
7/16-14	30	40.8	50	68.0	70	95.2
7/16-20	35	47.6	55	74.8	80	108.8
1/2-13	50	68.0	75	102.0	110	149.6
1/2-20	55	74.8	90	122.4	120	163.2
9/16-12	65	88.4	110	149.6	150	204.0
9/16-18	75	102.0	120	163.2	170	231.2
5/8-11	90	122.4	150	204.0	220	299.2
5/8-18	100	136	180	244.8	240	326.4
3/4-10	160	217.6	260	353.6	386	525.0
3/4-16	180	244.8	300	408.0	420	571.2
7/8-9	140	190.4	400	544.0	600	816.0
7/8-14	155	210.8	440	598.4	660	897.6
1-8	220	299.2	580	788.8	900	1,244.0
1-12	240	326.4	640	870.4	1,000	1,360.0

NOTES

- These torque values are to be used for all hardware excluding: locknuts, self-tapping screws, thread forming screws, sheet metal screws and socket head setscrews.
- Recommended seating torque values for locknuts:
 - for prevailing torque locknuts - use 65% of grade 5 torques.
 - for flange whizlock nuts and screws - use 135% of grade 5 torques.
- Unless otherwise noted on assembly drawings, all torque values must meet this specification.

Wrench & Fastener Size Guide



1/4" Bolt or Nut
Wrench—7/16"

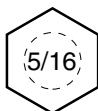

5/16" Bolt or Nut
Wrench—1/2"

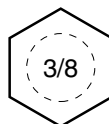

3/8" Bolt or Nut
Wrench—9/16"

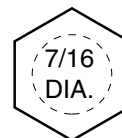

7/16" Bolt or Nut
Wrench (Bolt)—5/8"
Wrench (Nut)—11/16"

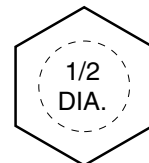

1/2" Bolt or Nut
Wrench—3/4"

Not for
Reproduction