

Parts Manual for

SNAPPER®

STEEL DECK VARIABLE SPEED DRIVE 53 cm MOWER NX SERIES

<i>Model No.</i>	<i>Description</i>
2691242-00	NX-90V



Briggs & Stratton Yard Power Products Group
535 Macon Road
McDonough, GA, 30253 U.S.A.
800-935-2967

Manual No.	1759436
Revision: -	2/17/2015

Not for
Reproduction

PAGE	GROUP
4	Handle Group
6	Deck Group
8	Engine & Blade Group
10	Drive Group

Not for
Reproduction

Handle Group

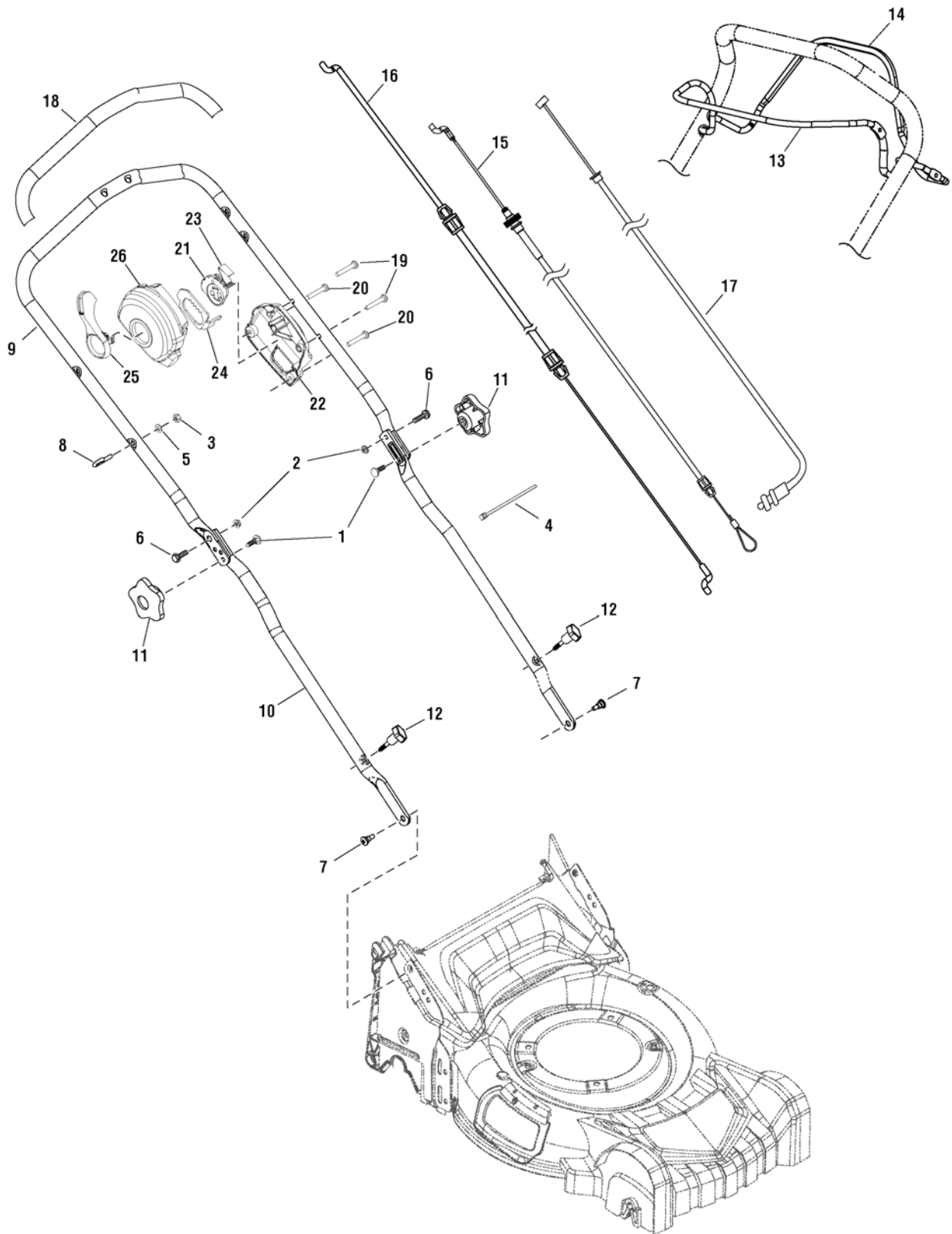

Item	Part No	Qty	Description
1	703483	2	BOLT, 5/16-18 x 1 G5
2	703463	2	NUT, Flange, 1/4-20
3	67885GS	1	NUT, Nylock, M6
4	704774	2	CABLE CLIP
5	703781	1	WASHER, A6.4
6	703522	2	SCREW, 1/4-20
7	704729	2	BOLT, Shoulder
8	704695	1	BOLT, Eye
9	704706	1	HANDLE, Upper
10	705712	2	HANDLE, Lower
11	704777	2	WING KNOB, 5/16-18
12	704779	2	WING KNOB
13	704715	1	BAIL, Control
14	704718	1	BAIL, Drive
15	704719	1	CABLE, Drive
16	704721	1	CABLE, Control
17	704724	1	CABLE, Speed Select
18	704778	1	GRIP
19	704790	2	SCREW, 184-15 x 1-1/2
20	704788	2	SCREW, 184-15 x 3/4
21	704773	1	SPEED ACTUATOR
22	704771	1	HOUSING, Lower
23	704736	1	SHIFT SPRING
24	704693	1	RACK PLATE
25	704770	1	LEVER, Speed Select
26	704811	1	HOUSING, Upper

Footnotes:

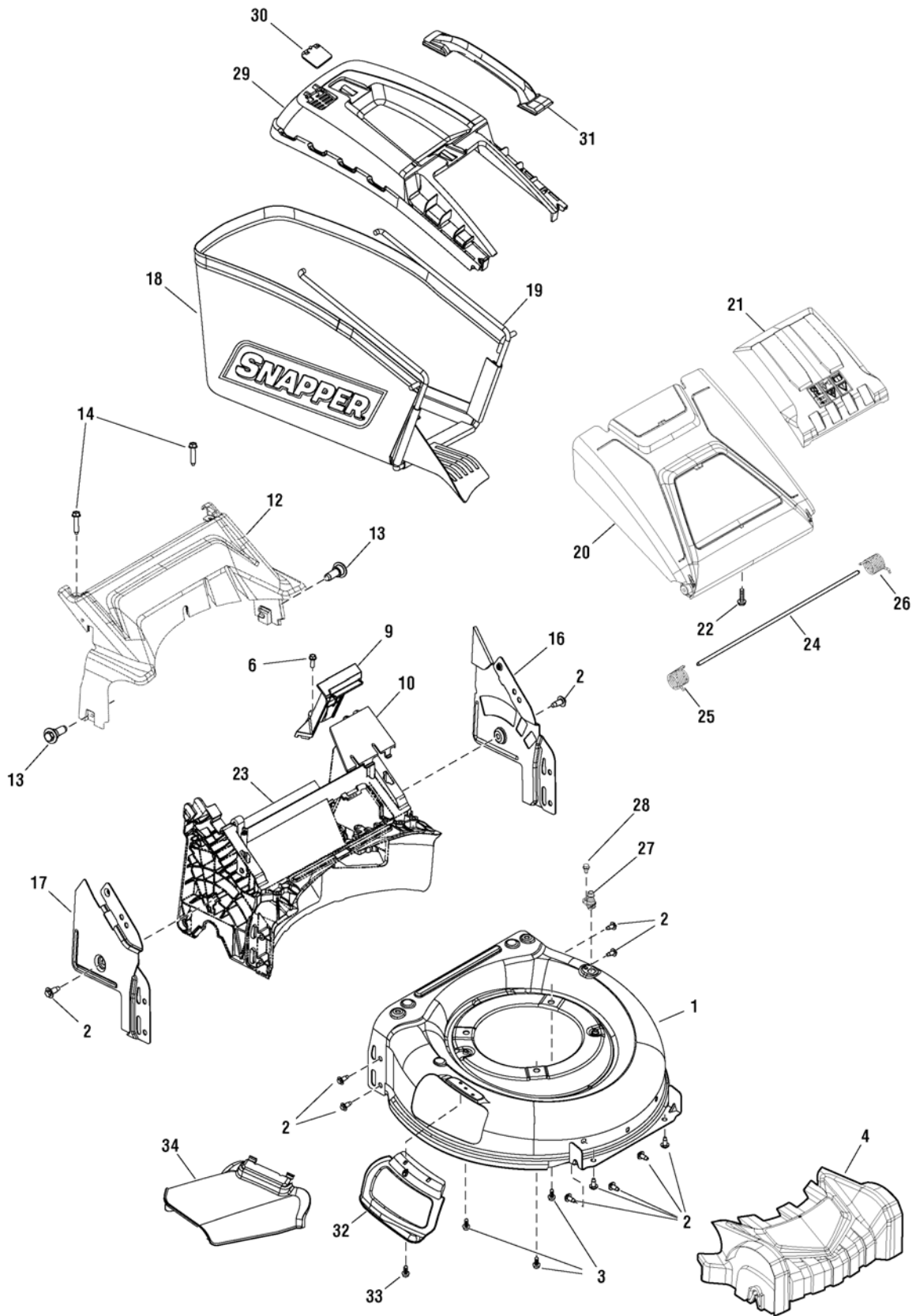

Item	Part No	Qty	Description
1	706867	1	DECK
2	704787	11	SCREW, Hex Head
3	703407	3	SCREW, 3/8-16 x 1
4	704975	1	FRONT COVER, Deck
6	7091081SM	1	SCREW, 1/4-15 x 3/4
9	704760	1	COVER, Rear
10	704759	1	COVER, Front
12	706868	1	COVER, Rear
13	703523	2	SCREW, 5/16-14
14	704789	2	SCREW, 1/4-15 x 1-1/4
16	704690	1	SUPPORT, Handle, LH
17	704689	1	SUPPORT, Handle, RH
18	704978	1	BAG
19	704979	1	FRAME
20	704980	1	REAR FLAP
21	704746	1	COVER, Gray
22	704786	2	SCREW #10-16 x 3/4
23	704810	1	GUIDE, Rear
24	704714	1	ROD
25	704735	1	TORSION SPRING, RH
26	704734	1	TORSION SPRING, LH
27	703502	1	NOZZLE, Wash
28	703714	1	SCREW, 1/4-20 x 1/2
29	704981	1	COVER, Bagger
30	703684	1	INDICATOR, Full Bag
31	704740	1	HANDLE
32	704792	1	MULCH FLAP
33	BG4300GS	1	SCREW, 1/4-20 x 1/2
34	704753	1	DEFLECTOR

Footnotes:

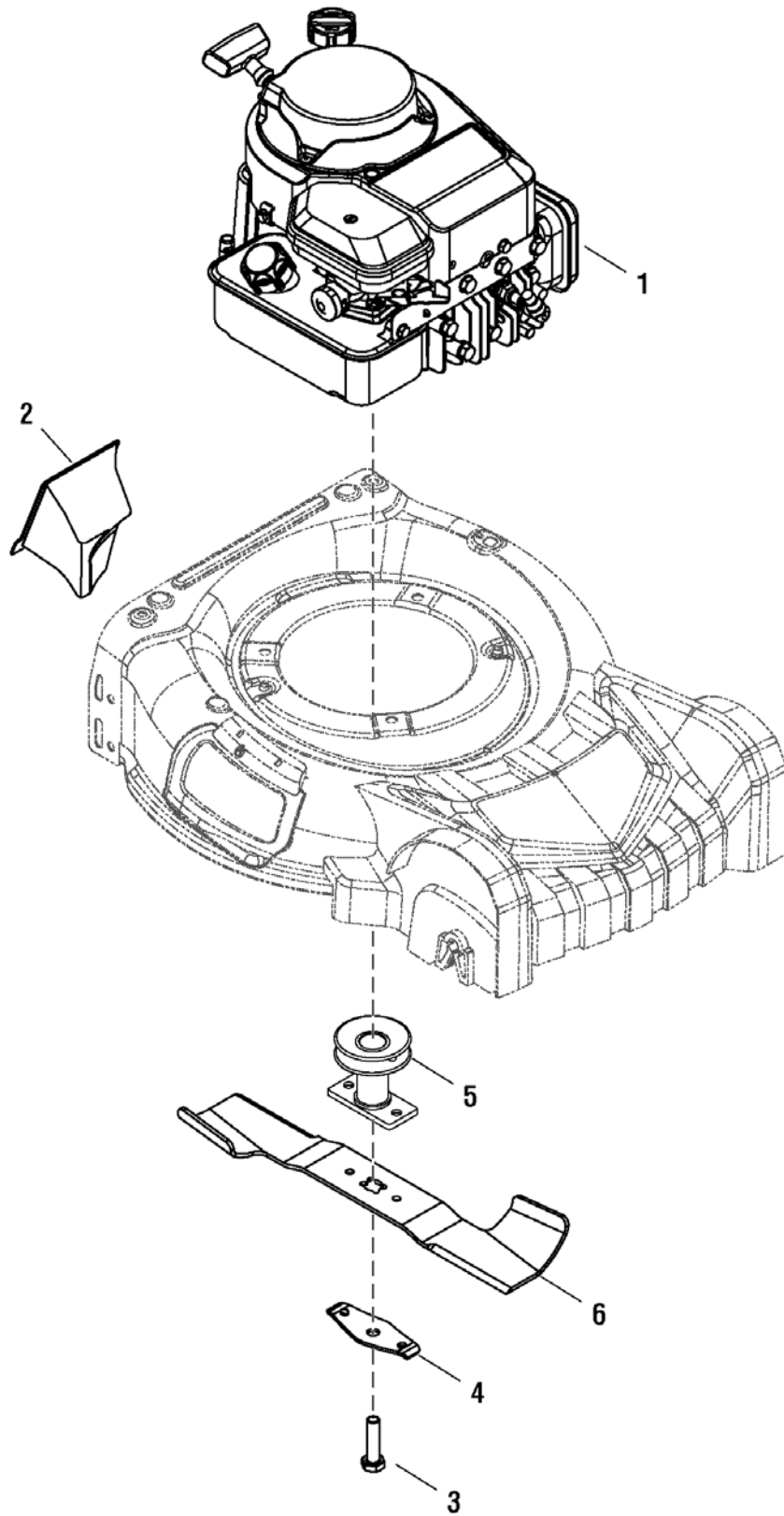

Item	Part No	Qty	Description
1	122S02-0007-H1	1	* ENGINE, Briggs & Stratton, Mod. 122S02-0007-H1
2	704765	1	MULCH PLUG
3	704785	1	SCREW Hex, 3/8-24 x 1-1/2
4	703520	1	SUPPORT, Blade Bell
5	703475	1	BLADE ADAPTER
6	704725	1	BLADE

Not for
Reproduction

Footnotes:

Note* To verify your specific engine model, please reference the ID Tag located on your engine. See your local Briggs & Stratton distributor for parts and service.

Item	Part No	Qty	Description
1	704819	1	AXLE, Front
2	704818	1	AXLE, Rear
3	7091081SM	4	SCREW, 1/4-15 x 3/4
4	5025394SM	4	NUT, FLANGE, 3/8-16
5	703714	2	SCREW, 1/4-20 x 1/2
6	703524	2	BUSHING, Lock
7	704707	1	TUBE
8	704780	1	KNOB, Red
8	703648	1	KNOB, Black
9	704977	2	WHEEL, 200 x 49
10	704807	2	WHEEL, Drive
11	703503	2	DUST COVER, Wheel
12	704751	2	HUBCAP, Front
13	704750	2	HUBCAP, Rear
14	703469	2	BEARING ASSEMBLY
15	703479	2	SCREW, Hex Washer Head, .159 x .43
16	7900023SM	5	SCREW, 1/4-15 x 1-1/4
17	703516	1	SPRING
18	703714	2	SCREW, 1/4-20 x 1/2
19	704694	1	BRACKET
20	706886	1	BELT
21	703542	1	SUPPORT
22	704782	2	GEAR, 9 Tooth
23	704814	1	COVER, Rear
24	706870	1	TRANSMISSION
25	706867	1	SPACER
26	706888	1	WASHER
27	704697	2	PULLEY HALF, Upper
28	704696	1	PULLEY HALF, Lower
29	704730	1	SHIM, 20
30	704731	1	SHIM, 10
31	704728	1	BEARING
32	704772	1	CAM PULLEY, Speed
33	704783	1	NUT, Lock

Footnotes:

Hardware Identification & Torque Specifications

Torque Specification Chart								
FOR STANDARD METRIC MACHINE HARDWARE (Tolerance ± 20%)								
Property Class	5.6		8.8		10.9		12.9	
	Class 5.6		Class 8.8		Class 10.9		Class 12.9	
Size Of Hardware	in/lbs		in/lbs		in/lbs		in/lbs	
	ft/lbs	Nm.	ft/lbs	Nm.	ft/lbs	Nm.	ft/lbs	Nm.
M3	5.88	.56	13.44	1.28	19.2	1.80	22.92	2.15
M4	13.44	1.28	30.72	2.90	43.44	4.10	52.56	4.95
M5	26.4	2.50	60.96	5.75	5.97	8.10	7.15	9.7
M6	44.64	4.3	7.3	9.9	10.3	14	12.1	16.5
M7	5.2	7.1	12.1	16.5	16.9	23	19.9	27
M8	7.7	10.5	17.7	24	25	34	29	40
M10	15	21	35	48	50	67	59	81
M12	26	36	61	83	86.2	117	103	140
M14	42	58	101	132	136	185	162	220
M16	64	88	147	200	210	285	250	340
M18	89	121	202	275	287	390	346	470
M20	126	171	290	390	405	550	486	660
M22	169	230	390	530	559	745	656	890
M24	217	295	497	375	708	960	840	1140
M27	320	435	733	995	1032	1400	1239	1680
M30	435	590	995	1350	1401	1900	1681	2280
M33	590	800	1349	1830	1902	2580	2278	3090
M36	759	1030	1740	2360	2441	3310	2935	3980
M39	988	1340	2249	3050	3163	4290	3798	5150

Torque Specification Chart						
FOR STANDARD MACHINE HARDWARE (Tolerance ± 20%)						
Hardware Grade	No Marks		SAE Grade 5		SAE Grade 8	
	SAE Grade 2		SAE Grade 5		SAE Grade 8	
Size Of Hardware	in/lbs		in/lbs		in/lbs	
	ft/lbs	Nm.	ft/lbs	Nm.	ft/lbs	Nm.
8-32	19	2.1	30	3.4	41	4.6
8-36	20	2.3	31	3.5	43	4.9
10-24	27	3.1	43	4.9	60	6.8
10-32	31	3.5	49	5.5	68	7.7
1/4-20	66	7.6	8	10.9	12	16.3
1/4-28	76	8.6	10	13.6	14	19.0
5/16-18	11	15.0	17	23.1	25	34.0
5/16-24	12	16.3	19	25.8	29	34.0
3/8-16	20	27.2	30	40.8	45	61.2
3/8-24	23	31.3	35	47.6	50	68.0
7/16-14	30	40.8	50	68.0	70	95.2
7/16-20	35	47.6	55	74.8	80	108.8
1/2-13	50	68.0	75	102.0	110	149.6
1/2-20	55	74.8	90	122.4	120	163.2
9/16-12	65	88.4	110	149.6	150	204.0
9/16-18	75	102.0	120	163.2	170	231.2
5/8-11	90	122.4	150	204.0	220	299.2
5/8-18	100	136	180	244.8	240	326.4
3/4-10	160	217.6	260	353.6	386	525.0
3/4-16	180	244.8	300	408.0	420	571.2
7/8-9	140	190.4	400	544.0	600	816.0
7/8-14	155	210.8	440	598.4	660	897.6
1-8	220	299.2	580	788.8	900	1,244.0
1-12	240	326.4	640	870.4	1,000	1,360.0

The guides and ruler furnished below are designed to help you select the appropriate hardware.

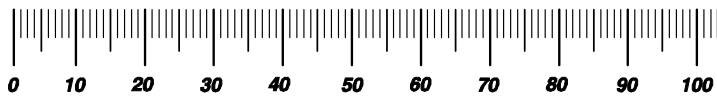

Nut, M8

Thread Diameter (mm)
Inside Diameter (in) Threads per inch

Nut, 1/2-16

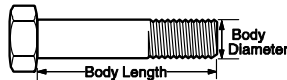

Screw, M8- 1.25 x 25

Thread Diameter (mm) Distance between threads (mm) Body Length (mm)
Body Diameter Threads per inch Body Length (in)

Screw, 1/2- 16 x 2

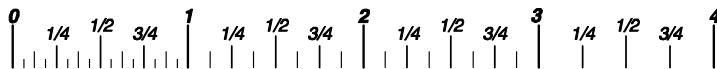

Standard Hardware Sizing

When a washer or nut is identified as 1/2" (M8), this is the *Nominal size*, meaning the *inside diameter* is 1/2 inch (8mm metric thread diameter); if a second number is present it represents the *threads per inch* (distance between threads).

When bolt or capscrew is identified as 1/2 - 16 x 2" (M8 - 1.25 x 50), this means the *Nominal size*, or body diameter is 1/2 inch (8mm metric thread diameter), the second number, 16, represents the *threads per inch*, (1.25 thread diameter). The final number is the body length of the bolt or screw, 2 inches (50mm).

NOTES

- These torque values are to be used for all hardware excluding: locknuts, self-tapping screws, thread forming screws, sheet metal screws and socket head setscrews.
- Recommended seating torque values for locknuts:
 - for prevailing torque locknuts - use 65% of grade5 torques.
 - for flange whizlock nuts and screws - use 135% of grade 5 torques.
- Unless otherwise noted on assembly drawings, all torque values must meet this specification.

Common Hardware Types

Hex Head Capscrew



Washer



Carriage Bolt



Lockwasher



Hex Nut



Wrench & Fastener Size Guide

1/4" Bolt or Nut Wrench—7/16"	5/16" Bolt or Nut Wrench—1/2"	3/8" Bolt or Nut Wrench—9/16"	7/16" Bolt or Nut Wrench (Bolt)—5/8" Wrench (Nut)—11/16"	1/2" Bolt or Nut Wrench—3/4"
M6 Bolt or Nut Wrench—10mm	M8 Bolt or Nut Wrench—13mm	M10 Bolt or Nut Wrench—17mm	M12 Bolt or Nut Wrench—19mm	M14 Bolt or Nut Wrench—22mm

Parts Manual for

SNAPPER®

STEEL DECK VARIABLE SPEED DRIVE 53 cm MOWER NX SERIES

Not for
Reproduction

IT IS THE POLICY OF BRIGGS & STRATTON CORP TO IMPROVE ITS PRODUCTS WHENEVER IT IS POSSIBLE AND PRACTICAL TO DO SO. WE RESERVE THE RIGHT TO MAKE CHANGES OR ADD IMPROVEMENTS AT ANY TIME WITHOUT INCURRING ANY OBLIGATION TO MAKE SUCH CHANGES ON PRODUCTS

Briggs & Stratton Yard Power Products Group

535 Macon Road
McDonough, GA, 30253 U.S.A.
800-935-2967

www.snapper.com

Copyright © 2015 Briggs & Stratton Corporation
Milwaukee, WI USA. All Rights Reserved

Manual No. 1759436

Revision: - 2/17/2015