



# Parts Manual



## ERDV19675HW

### Walk Behind Mower

#### Attachment

Mfg. No.	Description
881249	ERDV19675HW, 19" Variable Speed Walk Mower, CE

Manual Part No. 1751821

Revision A

Rev. Date: 12/6/2010



<b>PRODUCT COMPONENTS</b>	<b>PAGES</b>
Handles Group .....	4
Deck & Engine Group .....	6
Decals Group .....	10
Drive Group .....	12
<b>Torque Specification Chart .....</b>	<b>Inside Back Cover</b>



## Handles Group

REF NO	PART NO.	QTY.	DESCRIPTION
54	880635	1	CONTROL PANEL
300	880571	1	HANDLE, Lower
301	880673	1	HANDLE, Upper
302	881068Z	1	LEVER, Engine Stop
303	880639	1	CABLE, Engine Stop
304	880457	1	TUBING, Foam
305	724994	1	GUIDE, Rope
306	721800	4	KNOB, Adjuster
307	880615	2	WASHER, Formed
308	880329	1	LEVER, Drive
309	880458	1	CABLE ASSEMBLY, Drive
310	880652	1	THROTTLE CONTROL
311	880653	1	KNOB, Throttle Control
312	880328	1	COVER, SP Control
313	880929	1	SPRING, Compression
804	880607	2	WASHER, 5/8
807	880029	2	CABLE TIE
809	722856	4	SCREW, Self Tap, #10-16 x 1/2
815	880576	2	BOLT, Carriage, 5/16-18 x 1-1/8
816	720055	2	BOLT, Carriage, 5/16-18 x 2
817	22129GP	2	WASHER, Lock
822	722393	1	NUT, Hex, 1/4-20
827	880664	2	SCREW, 1/4-20 x 7/8
829	880070	2	SCREW, Hi-Lo, #10 x 1/2

## Footnotes

---

**The above parts group applies to the following Mfg. Nos.:**

881249 - ERDV19675HW



## Deck & Engine Group

REF NO	PART NO.	QTY.	DESCRIPTION
1	126T02-0275-B1	1	* ENGINE, B&S 675 Series, EU (Engine Model: 126T02-0275-B1)
2	881117C	1	MOWER HOUSING
3	880951A	1	BRACKET ASSEMBLY, Left Handle
4	880950A	1	BRACKET ASSEMBLY, Right Handle
6	880638	1	BLADE, 19"
7	880567	1	BLADE ADAPTER ASSEMBLY
8	880671	1	DOOR, Rear
9	880214	1	ROD, Rear Door
10	880942	1	SPRING, Torsion Rear Door, Right
11	880963Z	1	FRAME ASSEMBLY
12	880965	1	BAG ASSEMBLY
13	880909	1	MULCH PLUG
14	880943	1	SPRING, Torsion Rear Door, Left
50	881106	1	SIDE GUARD, Right
51	881109	1	SIDE GUARD, Left
52	880667	1	HOUSING COVER, Front
53	881047	1	HOUSING COVER, Rear
200	880696	2	WHEEL, Rear
201	880700	2	HUBCAP, Rear
202	880715	2	WHEEL ASSEMBLY, Front, 200MM 5 Spoke Tread II SI
203	880701	2	HUBCAP, Front
206	880550	1	CROSSBAR ASSEMBLY, Front
208	880050	2	BUSHING, Front Crossbar
209	881163	2	SPRING, Clip Crossbar
210	881174C	1	LINK, Single Lever
211	880052	1	SPRING, Extension
213	880855	1	REAR CROSSBAR
214	880642	1	SPRING, Adjuster
215	880540	1	LEVER, Height Adjustment
216	880325	1	KNOB, Adjuster
217	880959	1	BRACKET, Height Adjuster
300	880784	1	BAFFLE, Front
301	880785	1	BAFFLE, Rear
302	880664	5	SCREW, 1/4-20 x 1/2
303	880804	5	SCREW, 1/4-15 x 5/8
800	720044	3	SCREW, Hex Head, 3/8-16 x 1
801	880034	1	BOLT, Blade, 3/8-24 x 2
802	721890	1	WASHER, Belleville
804	880607	2	WASHER, Flat
805	880020	2	NUT, Nylock, M8 x 1-1/4
808	720142	4	NUT, Flange, 3/8-16
810	880323	2	BOLT, Hex Key Head
811	880428	4	NUT, Nylock

### Footnotes

NOTE: \* Purchase engine parts from engine manufacturer dealer.

---

**The above parts group applies to the following Mfg. Nos.:**

881249 - ERDV19675HW





## **Deck & Engine Group**

---

<b>REF NO</b>	<b>PART NO.</b>	<b>QTY.</b>	<b>DESCRIPTION</b>
813	880339	2	SCREW, Torx Head, M5 x .8 x 14mm
818	7091020	2	PUSHNUT, 1/4
819	880577	2	SCREW, Torx Head, M5 x .8 x 12.5mm
823	880651	2	BOLT, Shoulder, 5/16-18 x 1
824	720145	6	NUT, Flange, 5/16-18
826	880456	2	SCREW, 1/4-20 x 7/8
830	727291	4	SCREW , 5/16-18 x 3/4
834	880859	2	NUT, Flange Lock, 1/4-20

### **Footnotes**

NOTE: \* Purchase engine parts from engine manufacturer dealer.

---

**The above parts group applies to the following Mfg. Nos.:**

881249 - ERDV19675HW

## Decals Group

NOTE: Unless noted otherwise,  
use the standard hardware torque  
specification chart.

\\log Data\SMP\Images\groups\8800000\881249dcl

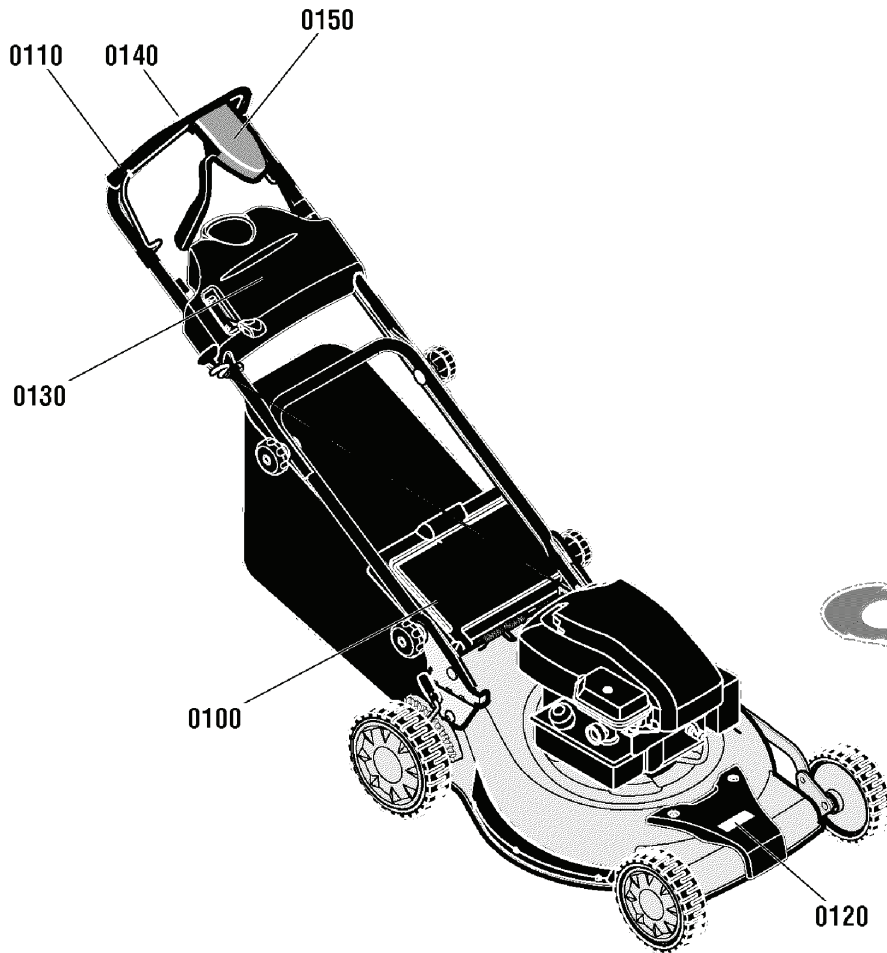

0110



0140



0100



0130

The above parts group applies to the following Mfg. Nos.:

881249 - ERDV19675HW

## ***Decals Group***

---

<b>REF NO</b>	<b>PART NO.</b>	<b>QTY.</b>	<b>DESCRIPTION</b>
0100	880360	1	DECAL, Warning Symbols
0110	880545	1	DECAL, Engine Control Lever
0120	881408	1	DECAL, Logo, Deck
0130	1722551	1	DECAL, Logo, Cover
0140	880544	1	DECAL, Drive Control Lever
0150	881269	1	DECAL, Drive Cover

## **Footnotes**

---

**The above parts group applies to the following Mfg. Nos.:**

881249 - ERDV19675HW

## Drive Group

881249dr

NOTE: Unless noted otherwise,  
use the standard hardware torque  
specification chart.

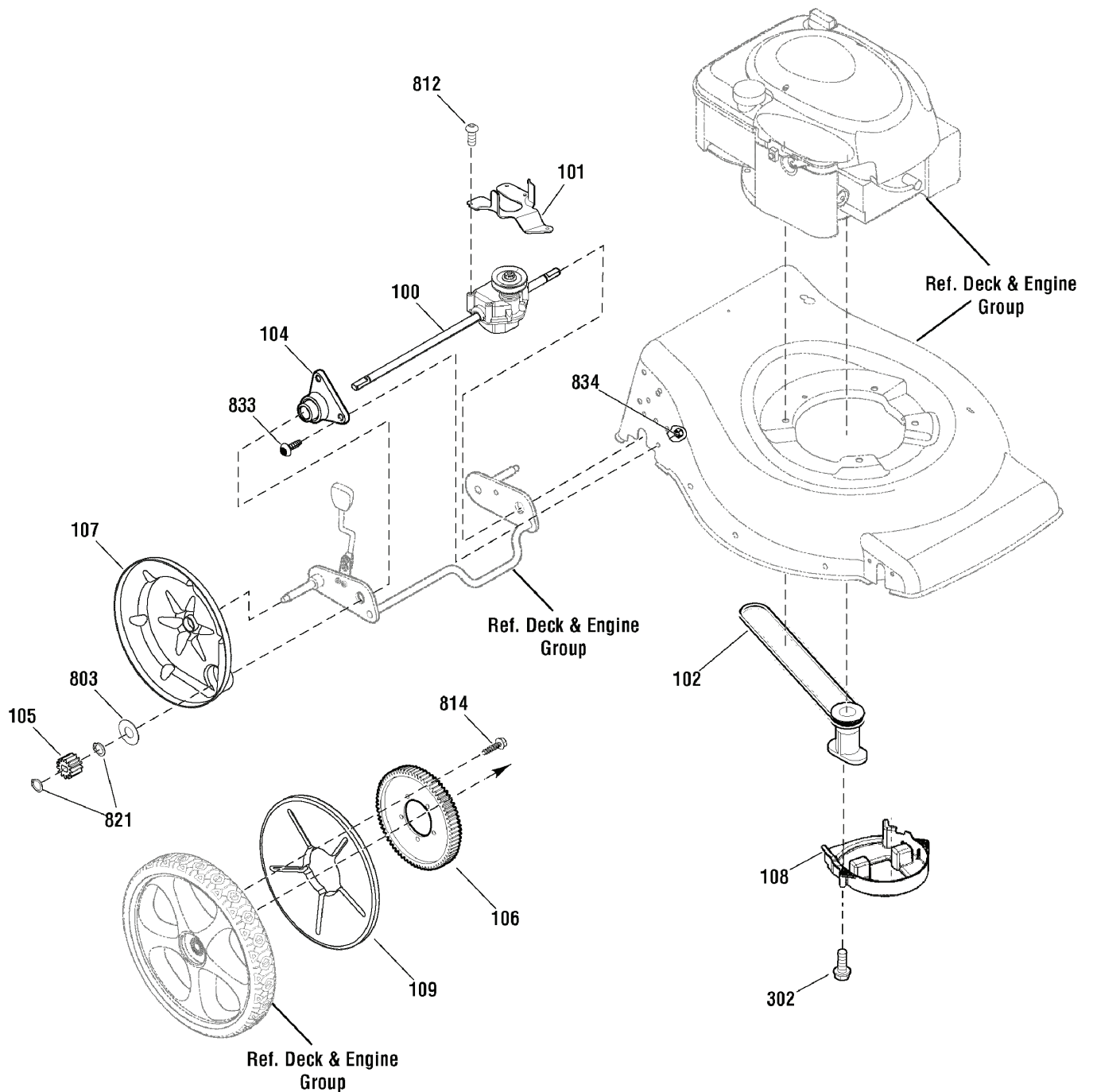

The above parts group applies to the following Mfg. Nos.:

881249 - ERDV19675HW

## **Drive Group**

---

<b>REF NO</b>	<b>PART NO.</b>	<b>QTY.</b>	<b>DESCRIPTION</b>
100	880604	1	TRANSMISSION
101	880282	1	BELT GUIDE, Transmission
102	880268	1	V-BELT
104	880787	2	SLEEVE ASSEMBLY, Rear Axle
105	880527	2	GEAR, Pinion
106	880526	2	GEAR, Drive
107	880528	2	DUST COVER
108	880796	1	BELT COVER ASSEMBLY
109	880539	2	COVER, Wheel
302	880644	2	SCREW, 1/4-20 x 1/2
803	880324	2	WASHER, Thrust
812	880760	3	SCREW, #10 x 1
814	722881	10	SCREW, 1/4-15 x 3/4
821	880269	4	RING, External Retaining
833	880845	4	SCREW, Torx, 1/4-20 x 5/8
834	880859	4	NUT, Flange Lock, 1/4-20

## **Footnotes**

---

**The above parts group applies to the following Mfg. Nos.:**

881249 - ERDV19675HW



# Hardware Identification & Torque Specifications

Torque Specification Chart								
FOR STANDARD METRIC MACHINE HARDWARE (Tolerance ± 20%)								
Property Class	5.6		8.8		10.9		12.9	
	Class 5.6		Class 8.8		Class 10.9		Class 12.9	
Size Of Hardware	in/lbs	Nm.	in/lbs	Nm.	in/lbs	Nm.	in/lbs	Nm.
	ft/lbs		ft/lbs		ft/lbs		ft/lbs	
M3	5.88	.56	13.44	1.28	19.2	1.80	22.92	2.15
M4	13.44	1.28	30.72	2.90	43.44	4.10	52.56	4.95
M5	26.4	2.50	60.96	5.75	5.97	8.10	7.15	9.7
M6	44.64	4.3	7.3	9.9	10.3	14	12.1	16.5
M7	5.2	7.1	12.1	16.5	16.9	23	19.9	27
M8	7.7	10.5	17.7	24	25	34	29	40
M10	15	21	35	48	50	67	59	81
M12	26	36	61	83	86.2	117	103	140
M14	42	58	101	132	136	185	162	220
M16	64	88	147	200	210	285	250	340
M18	89	121	202	275	287	390	346	470
M20	126	171	290	390	405	550	486	660
M22	169	230	390	530	559	745	656	890
M24	217	295	497	375	708	960	840	1140
M27	320	435	733	995	1032	1400	1239	1680
M30	435	590	995	1350	1401	1900	1681	2280
M33	590	800	1349	1830	1902	2580	2278	3090
M36	759	1030	1740	2360	2441	3310	2935	3980
M39	988	1340	2249	3050	3163	4290	3798	5150

The guides and ruler furnished below are designed to help you select the appropriate hardware.



Nut, M8

Thread Diameter (mm)  
Inside Diameter (in)  
Threads per inch

Nut, 1/2-16

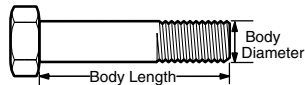

Screw, M8- 1.25 x 25

Thread Diameter (mm)  
Body Diameter  
Distance between threads (mm)  
Threads per inch  
Body Length (mm)  
Body Length (in)

Screw, 1/2- 16 x 2

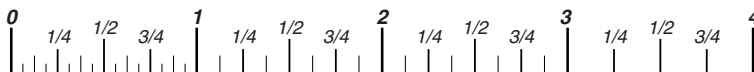

## Standard Hardware Sizing

When a washer or nut is identified as **1/2"** (M8), this is the *Nominal size*, meaning the *inside diameter* is 1/2 inch (8mm metric thread diameter); if a second number is present it represents the *threads per inch* (distance between threads).

When bolt or capscrew is identified as **1/2 - 16 x 2"** (M8 - 1.25 x 50 ), this means the *Nominal size*, or body diameter is 1/2 inch (8mm metric thread diameter), the second number, 16, represents the *threads per inch*, (1.25 thread diameter). The final number is the body length of the bolt or screw, 2 inches (50mm).

Torque Specification Chart						
FOR STANDARD MACHINE HARDWARE (Tolerance ± 20%)						
Hardware Grade	No Marks		SAE Grade 5		SAE Grade 8	
	SAE Grade 2		SAE Grade 5		SAE Grade 8	
Size Of Hardware	in/lbs	Nm.	in/lbs	Nm.	in/lbs	Nm.
	ft/lbs		ft/lbs		ft/lbs	
8-32	19	2.1	30	3.4	41	4.6
8-36	20	2.3	31	3.5	43	4.9
10-24	27	3.1	43	4.9	60	6.8
10-32	31	3.5	49	5.5	68	7.7
1/4-20	66	7.6	8	10.9	12	16.3
1/4-28	76	8.6	10	13.6	14	19.0
5/16-18	11	15.0	17	23.1	25	34.0
5/16-24	12	16.3	19	25.8	29	34.0
3/8-16	20	27.2	30	40.8	45	61.2
3/8-24	23	31.3	35	47.6	50	68.0
7/16-14	30	40.8	50	68.0	70	95.2
7/16-20	35	47.6	55	74.8	80	108.8
1/2-13	50	68.0	75	102.0	110	149.6
1/2-20	55	74.8	90	122.4	120	163.2
9/16-12	65	88.4	110	149.6	150	204.0
9/16-18	75	102.0	120	163.2	170	231.2
5/8-11	90	122.4	150	204.0	220	299.2
5/8-18	100	136	180	244.8	240	326.4
3/4-10	160	217.6	260	353.6	386	525.0
3/4-16	180	244.8	300	408.0	420	571.2
7/8-9	140	190.4	400	544.0	600	816.0
7/8-14	155	210.8	440	598.4	660	897.6
1-8	220	299.2	580	788.8	900	1,244.0
1-12	240	326.4	640	870.4	1,000	1,360.0

## NOTES

- These torque values are to be used for all hardware excluding: locknuts, self-tapping screws, thread forming screws, sheet metal screws and socket head setscrews.
- Recommended seating torque values for locknuts:
  - for prevailing torque locknuts - use 65% of grade 5 torques.
  - for flange whizlock nuts and screws - use 135% of grade 5 torques.
- Unless otherwise noted on assembly drawings, all torque values must meet this specification.

## Common Hardware Types

Hex Head Capscrew



Washer



Carriage Bolt



Hex Nut

## Wrench & Fastener Size Guide

1/4" Bolt or Nut Wrench—7/16"	5/16" Bolt or Nut Wrench—1/2"	3/8" Bolt or Nut Wrench—9/16"	7/16" Bolt or Nut Wrench (Bolt)—5/8" Wrench (Nut)—11/16"	1/2" Bolt or Nut Wrench—3/4"
M6 Bolt or Nut Wrench—10mm	M8 Bolt or Nut Wrench—13mm	M10 Bolt or Nut Wrench—17mm	M12 Bolt or Nut Wrench—19mm	M14 Bolt or Nut Wrench—22mm

**IT IS THE POLICY OF BRIGGS & STRATTON CORP. TO IMPROVE ITS PRODUCTS  
WHENEVER IT IS POSSIBLE AND PRACTICAL TO DO SO. WE RESERVE THE RIGHT TO  
MAKE CHANGES OR ADD IMPROVEMENTS AT ANY TIME WITHOUT INCURRING ANY  
OBLIGATION TO MAKE SUCH CHANGES ON PRODUCTS.**

**Briggs & Stratton Yard Power Products Group**

---

3515 N. 124 Street / PO Box 702  
Wauwatosa, WI 53222 USA

[www.simplicitymfg.com](http://www.simplicitymfg.com)

© Copyright 2010 by Briggs & Stratton Corporation  
Milwaukee, WI, USA. All rights reserved