

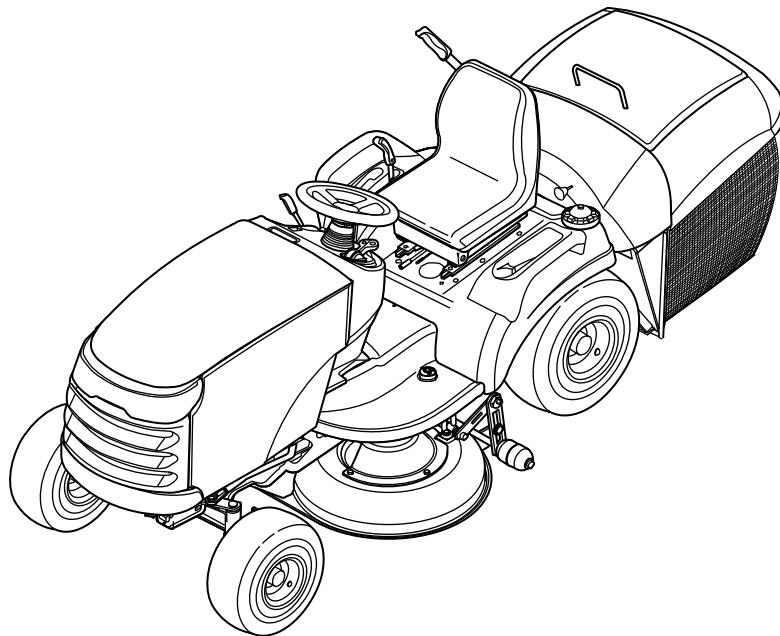

Parts Manual



Baron

Series Lawn Tractor & Mower Deck

21HP Product

Mfg. No.	Description
2690773	Baron, 21HP Hydro 4WD and 40" Mower Deck (CE/Export)

Manual Part No. 1735274

Revision C

Rev. Date: 7/6/2010

Not for
Reproduction

PRODUCT COMPONENTS	PAGES
Frame & Front Axle Group - 4WD	4
Steering Group - Power	8
Steering Group - Tilt Steering	10
Engine Group - Electric Clutch - 21HP Briggs & Stratton, Vanguard	12
Transmission Group - Tuff Torq K664	14
Transmission SERVICE PARTS - Tuff Torq K664J	18
Control Group - Cruise Control	24
Controls Group	26
Electrical Group	30
Hood, Grille & Dash Group	34
Seat Deck & Fuel Tank Group	36
Hopper Group	38
Wheels & Tires Group	42
Decals Group - Brand & Model	44
Decals Group - Safety & Common	46
40" Mower Deck - Belt, Idle Arm & Hitch	48
40" Mower Deck - Height Adjustment & Roller Bar	50
40" Mower Deck - Housing, Arbors & Blade	54
Torque Specification Chart	Inside Back Cover

Not for
Reproduction

Frame & Front Axle Group - 4WD

987913

NOTE: Unless noted otherwise,
use the standard hardware torque
specification chart.

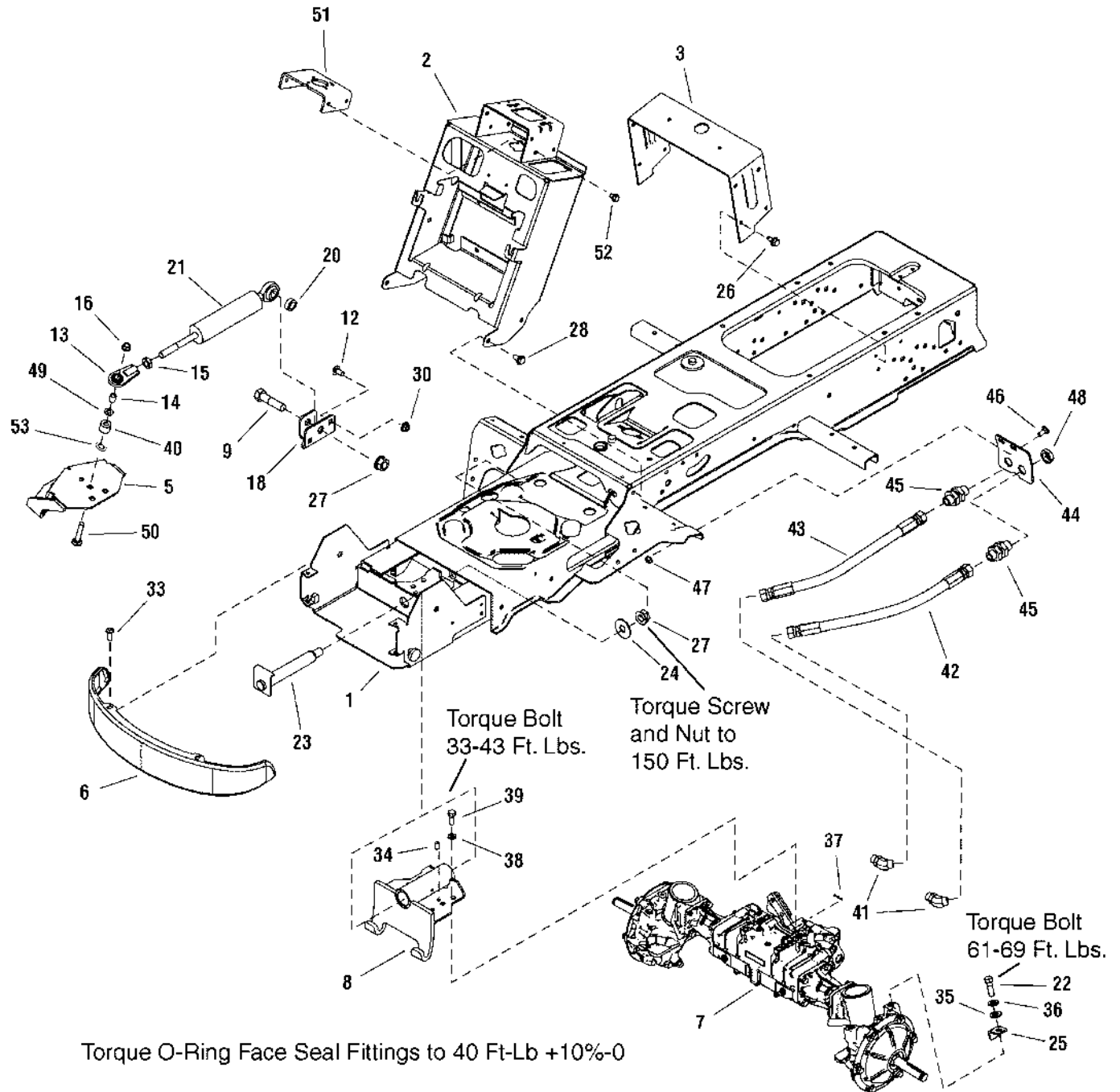

The above parts group applies to the following Mfg. Nos.:

2690773 - Baron

Frame & Front Axle Group - 4WD

REF NO	PART NO.	QTY.	DESCRIPTION
1	1735085ASM	1	FRAME ASSEMBLY, Front & Rear 4WD
2	1733139ASM	1	TOWER & SUPPORT ASSEMBLY
3	1723528ASM	1	SUPPORT, Seat Deck
5	1733918ASM	1	BRACKET ASSEMBLY, Steering 4WD
6	1721805ASM	1	BUMPER, 4GA
7	1736007SM	1	AXLE ASSEMBLY, Front
8	1734241ASM	1	PIVOT ASSEMBLY, Axle w/Bushings
9	1960755SM	1	CAPSCREW, Hex Head, 5/8-11 x 2-1/2 G5
12	1931348SM	2	CARRIAGE BOLT, 3/9-16 x 3/4 G5
13	1702779SM	1	JOINT, Ball 1/2-20
14	1708236SM	1	SPACER
15	1919262SM	1	NUT, Hex Jam, 1/2-20
16	1930645SM	1	NUT, Hex Flange, 3/8-16 Two-Way Lock
18	1733166ASM	1	BRACKET, Cylinder Mounting
20	2172914SM	1	SPACER
21	1733759SM	1	CYLINDER, Hydraulic Steering
22	197487SM	3	CAPSCREW, Hex Head, M12-1-3/4 x 35
23	1733863SM	1	SHAFT & BRACKET ASSEMBLY, Axle Pivot
24	1960035SM	2	WASHER, 5/8
25	1734511ASM	1	STOP, "L" Steering
26	1664847SM	4	SCREW, Hex Washer Head Taptite, 5/16-18 x 3/4
27	2860646SM	2	NUT, Hex Flange 5/8-11 Two-Way Lock
28	1923683SM	4	SCREW, Hex Washer head, Taptite, 3/8-16 x 3/4
30	1928352SM	2	NUT, Hex Flange 3/8-16 Whiz Lock
33	1960086SM	4	SCREW, Truss Head Torx Drive 5/16-18 x 7/8
34	1733581SM	2	PIN, Dowel
35	1960170SM	3	WASHER, 1/2
36	1916966SM	3	LOCKWASHER, Spring
37	1923360SM	1	PIN, Cotter
38	1960754SM	6	LOCKWASHER, Spring
39	1950036SM	6	CAPSCREW, Hex Head
40	1667812SM	1	SPACER, Powdered Metal
41	1733403SM	2	FITTING, Hose Elbow, 45 Degrees, 13/16-16 x 3/4-16
42	1733400SM	1	HOSE ASSEMBLY, Hydraulic
43	1733891SM	1	HOSE ASSEMBLY, Hydraulic
44	1733501ASM	1	BRACKET, Hose Mounting 10GA
45	1733402SM	2	FITTING, Bulkhead Union 13/16-16
46	1931333SM	2	CARRIAGE BOLT, 5/16-18 x 3/4 G5
47	1960636SM	2	NUT, Hex KEPS, 5/16-18
48	1733947SM	2	NUT, Jam 13/16-16
49	1960103SM	1	WASHER, 3/8
50	1931355SM	1	CARRIAGE BOLT, 3/8-16 x 2-1/4 G5
51	1733044ASM	1	SUPPORT, Steering Unit 7GA

Footnotes

The above parts group applies to the following Mfg. Nos.:

2690773 - Baron

Frame & Front Axle Group - 4WD

987913

NOTE: Unless noted otherwise,
use the standard hardware torque
specification chart.

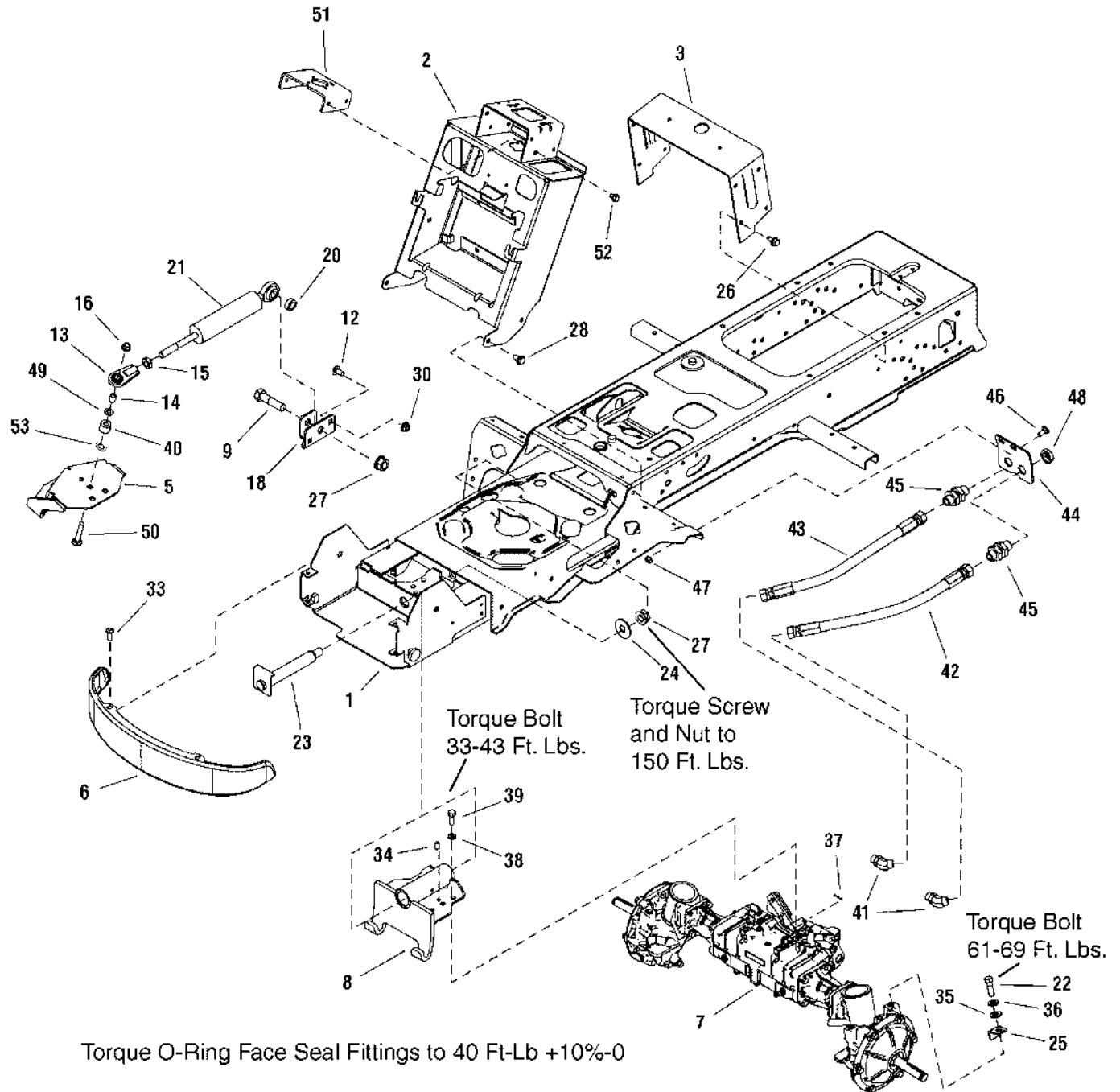

The above parts group applies to the following Mfg. Nos.:

2690773 - Baron

Frame & Front Axle Group - 4WD

REF NO	PART NO.	QTY.	DESCRIPTION
52	1924856SM	4	SCREW, Hex Washer Head Taptite 5/16-18 x 1/2
53	1723866SM	1	NUT, Push 3/8

Not for
Reproduction

Footnotes

The above parts group applies to the following Mfg. Nos.:

2690773 - Baron

Steering Group - Power

REF NO	PART NO.	QTY.	DESCRIPTION
1	1960141SM	2	WASHER, Flat, 5/16
2	1735083SM	1	TUBE, Filter (To Steer Unit - Port "T")
3	1735080SM	1	TUBE, Hydro (Hydro-Filter)
4	1722123SM	4	FITTING, Hydraulic, Straight
5	1735142SM	1	TUBE, Hydro (Trans Out Port "P")
6	1733894SM	1	POWER STEERING UNIT
7	1916964SM	4	LOCKWASHER, Spring, 1/4
8	2860444SM	4	CAPSCREW, Hex, M06, 1.0 x 16mm
9	2825094SM	2	TIE, Wire
10	1735445ASM	1	SUPPORT, Filter
11	1931646SM	2	SCREW, Whiz-Lock, 1/4-20 x .50
12	1733230SM	2	FITTING, Perma-Push
13	1921332SM	1	CAPSCREW, Hex, 5/16-18 x .75
14	1719168SM	1	FILTER, Oil
15	1719169SM	1	MANIFOLD, Oil Filter
16	1960636SM	1	NUT, KEPS-Lock, 5/16-18
17	1708007SM	1	CLIP
18	1960373SM	1	SCREW, Taptite, 5/16-18 x 1.0
19	1664847SM	1	SCREW, Taptite, 5/16-18 x .75
25	1733893SM	1	HOSE ASSEMBLY, Hydraulic Rubber, 27" Port R
26	1733791SM	1	HOSE ASSEMBLY, Hydraulic Rubber, 18" Port T
27	1733780SM	1	HOSE ASSEMBLY, Hydraulic Rubber, 26" Port P
28	1733595SM	1	HOSE ASSEMBLY, Hydraulic Rubber, 31" Port L
29	1733894SM	1	POWER STEERING ASSEMBLY, 32 CC, 4 Ports (Includes Ref. Nos. 6, 25, 26, 27 & 28)

Footnotes

The above parts group applies to the following Mfg. Nos.:

2690773 - Baron

Steering Group - Tilt Steering

987424

NOTE: Unless noted otherwise,
use the standard hardware torque
specification chart.

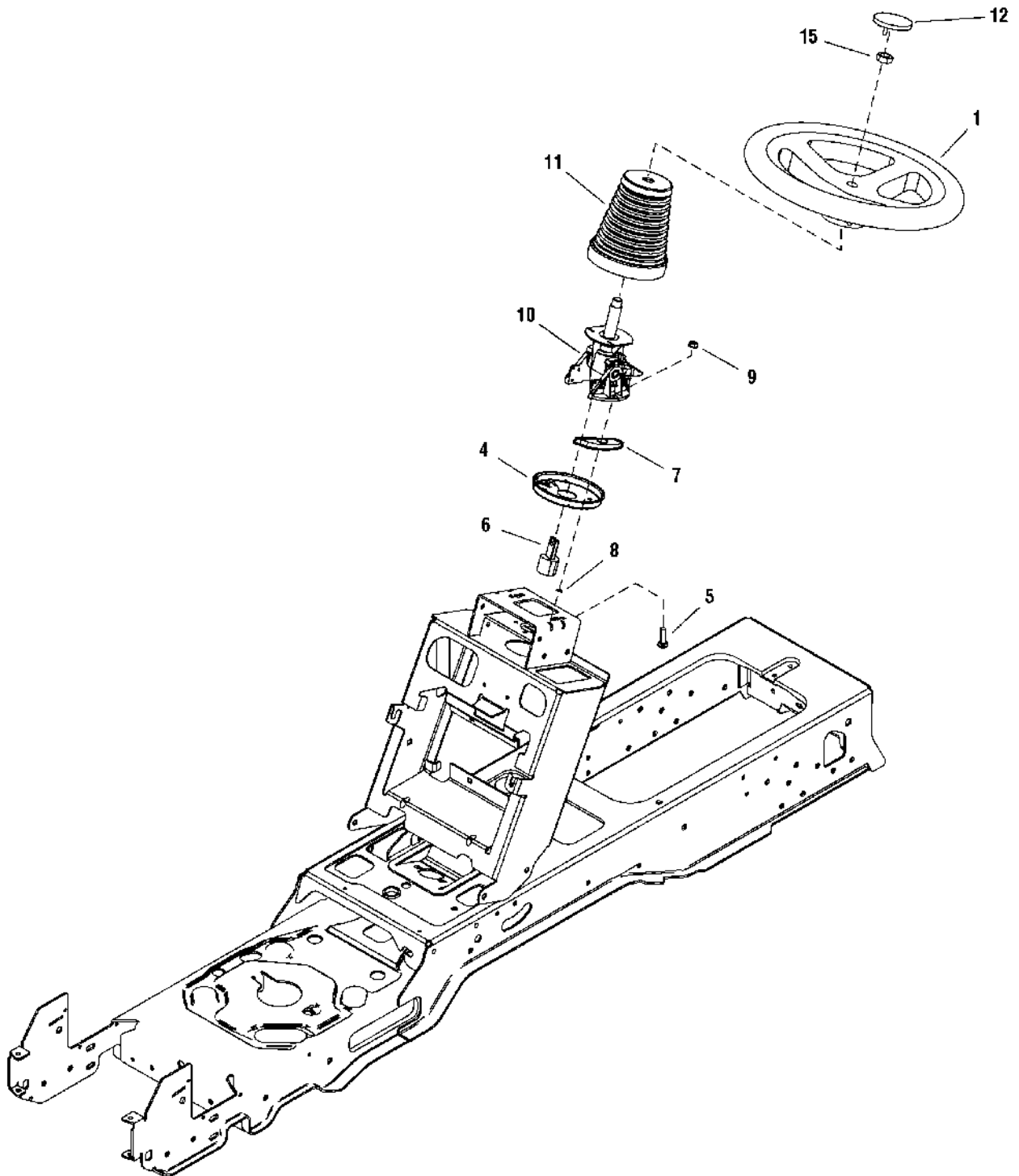

The above parts group applies to the following Mfg. Nos.:

2690773 - Baron

Steering Group - Tilt Steering

REF NO	PART NO.	QTY.	DESCRIPTION
1	1733363SM	1	STEERING WHEEL
4	1724685ASM	1	PLATE, Steering Mounting
5	1960655SM	2	BOLT, Carriage, 5/16-18 x 1-1/4, G5
6	1725294SM	1	ADAPTER
7	1723898SM	2	SPACER, Flat
8	1933988SM	2	NUT, Push Pal
9	1960636SM	2	NUT, Hex Keps 5/16-18
10	1734002SM	1	STEERING UNIT, Tilt
11	1724368SM	1	BELLOWS, Tilt Steering Unit w/Slot
12	1725024SM	1	CAP, Steering Wheel
15	1960576SM	1	NUT, Hex Lock ESNA Light 5/8-18

Not for
Reproduction

Footnotes

The above parts group applies to the following Mfg. Nos.:

2690773 - Baron

Engine Group - Electric Clutch - 21HP Briggs & Stratton, Vanguard

NOTE: Unless noted otherwise, use the standard hardware torque specification chart.

2987912

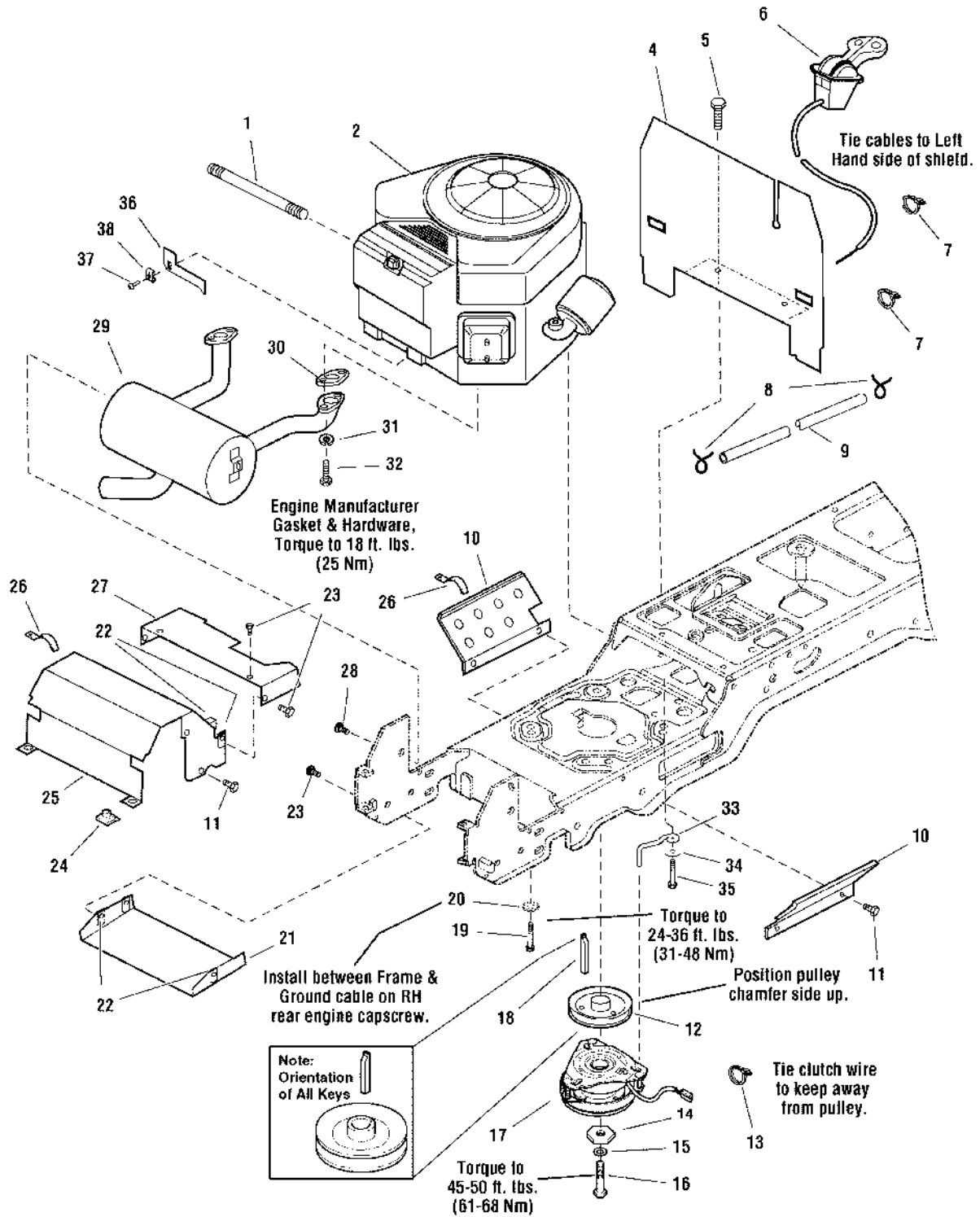

The above parts group applies to the following Mfg. Nos.:

2690773 - Baron

Engine Group - Electric Clutch - 21HP Briggs & Stratton, Vanguard

REF NO	PART NO.	QTY.	DESCRIPTION
1	1723165SM	1	HOSE, Oil Drain, 10-1/2" Long, 3/8-18 Fittings
2	385777-0119-G1	1	*ENGINE, 21HP Briggs & Stratton Vanguard Twin (Engine Model 385777-0119-G1)
4	1722388ASM	1	BULKHEAD
5	1925003SM	2	CAPSCREW, Hex Washer Head Taptite, 1/2-20 x 1/2, Black
6	1734506SM	1	CONTROL, Throttle Double 39" Long w/Knobs
7	2825094SM	2	TIE, Wire, 7-5/16" Long
8	791850	2	CLAMP, Hose Type E
9	1734984SM	1	HOSE, Fuel, 59" Long
10	1722392ASM	2	SHIELD, Side
11	1927428SM	8	CAPSCREW, Hex Washer Head Taptite, 1/4-20 x 3/8
12	1722288SM	1	PULLEY & HUB ASSEMBLY
13	2832747SM	1	TIE, Self Locking, 3-5/8 Long
14	1708264SM	1	WASHER, Hex, 7/16, Black
15	1918199SM	1	LOCKWASHER, 7/16
16	1960648SM	1	CAPSCREW, Hex Head, 7/16-20 x 3-3/4
17	1686880SM	1	CLUTCH, Electric
18	1720463SM	1	KEY, HI PRO, 1/4 x 2 1/2
19	2830598SM	4	CAPSCREW, Hex Washer Head Taptite, 3/8-16 x 1-1/2
20	2820427SM	1	LOCKWASHER, External Tooth, 3/8
21	1722414ASM	1	SHIELD, Muffler Bottom
22	1960368SM	8	NUT, Speed, 1/4-20, Lug
23	1960295SM	4	CAPSCREW, Hex Flange Whiz Lock, 1/4-20 x 5/8
24	1935255SM	2	NUT, Speed, 5/16-18, Lug, Black
25	1722389ASM	1	DUCT, Muffler Top
26	2834683SM	2	CLIP, Wire 1/8
27	1722390ASM	1	DUCT, Muffler Extension
28	1924856SM	2	CAPSCREW, Hex Washer Head Taptite, 5/16-18 x 1/2, Black
29	1726920SM	1	MUFFLER, Briggs & Stratton, Vanguard Twin
30	*	1	GASKET, Briggs & Stratton, Vanguard Twin
31	*	4	LOCKWASHER, 5/16
32	*	4	CAPSCREW, Hex Flange Whiz Lock, 5/16-18 x 7/8
33	1732026SM	1	RETAINER, Clutch
34	1924940SM	1	WASHER, Flat 3/8
35	2827187SM	1	CAPSCREW, 3/8-16 x 1
36	1732396SM	1	PLATE, RMP Limiter
37	1728125SM	1	SCREW, Pan Head Torx
38	1728126SM	1	THROTTLE CABLE - Clamp

Footnotes

Note* See your local Briggs & Stratton distributor for parts and service.

The above parts group applies to the following Mfg. Nos.:

2690773 - Baron

Transmission Group - Tuff Torq K664

NOTE: Unless noted otherwise, use the standard hardware torque specification chart.

2987917

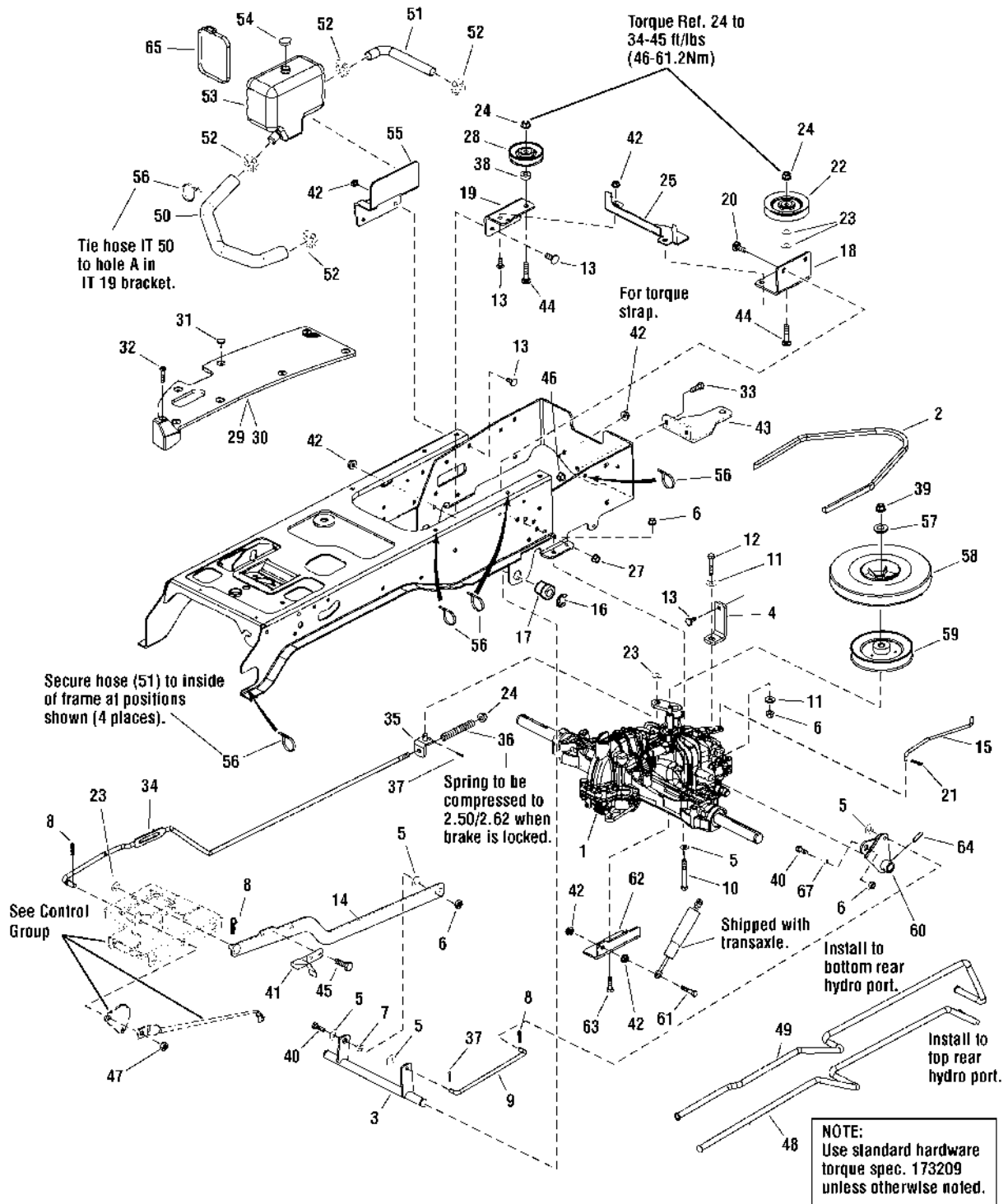

The above parts group applies to the following Mfg. Nos.:

2690773 - Baron

Transmission Group - Tuff Torq K664

REF NO	PART NO.	QTY.	DESCRIPTION
1	1735070YP	1	TRANSMISSION ASSEMBLY, Tuff Torq K664
2	1719911SM	2	V-BELT (117.00)
3	1727552SM	1	SHAFT & ARMS ASSEMBLY, Control
4	1734956AYP	1	STRAP, Torque
5	1919326SM	9	WASHER, 5/16
6	1960684SM	8	NUT, Hex, CON, Lock, 5/16-18
7	1666697SM	1	SPACER, Powered Metal
8	1722460SM	4	PIN, Quick
9	1734965SM	1	ROD, Control
10	1923141SM	4	CAPSCREW, Hex Head, 5/16-18 x 2-3/4 G5
11	1960141SM	2	WASHER, 5/16
12	1921978SM	1	CAPSCREW, Hex Head 5/16-18 x 2 G5
13	1931333SM	7	CARRIAGE BOLT, 5/16-18 x 3/4 G5
14	1727473SM	1	ARM & PIN ASSEMBLY, Speed Control
15	1734970SM	1	ROD, Free Wheel
16	2827794SM	2	RING, E Retaining
17	2176440SM	2	BUSHING, Nylon
18	1734966AYP	1	SUPPORT, Transmission, LH
19	1734967AYP	1	SUPPORT, Transmission, RH
20	1931350SM	2	CARRIAGE BOLT, 3/8-16 x 1 G5
21	7023590SM	1	COTTER PIN, 1/4
22	1710545SM	1	PULLEY, Idler, 4 in.
23	1924940SM	6	WASHER, 3/8
24	1960687SM	3	NUT, Hex Flange 3/8-16 ESNA
25	1734958AYP	1	BRACKET, Chute Locator
27	1960637SM	2	NUT, Lock, KEPS, 3/8-16
28	2174561SM	1	PULLEY, V Idler (3.0)
29	1722173SM	1	PAD, Footrest, RH Black Vinyl Textured
30	1722174SM	1	PAD, Footrest with Differential Lock, LH Black Vinyl Textures
31	1704351SM	15	FASTENER, Panel 3/4 Head
33	1921210SM	2	CAPSCREW, Hex Head, 3/8-16X1.000 G5 BLK
33	1921210SM	2	CAPSCREW, Hex, 3/8-16 x 1.0
34	1735108SM	1	ROD, Brake
35	1735110YP	1	BRAKE, Bracket Assembly
36	1729277SM	1	SPRING, Compression
37	1918447SM	2	PIN, Cotter
39	1719968SM	1	NUT, Flange, Nylock, M10
40	1921333SM	2	CAPSCREW, Hex Head, 5/16-18 x 1 G5
41	1727215ASM	1	ACTUATOR, Switch
42	1960684SM	9	NUT, Hex KEPS, 5/16-18 Conical Washer
43	1734980AYP	1	DRAWBAR
44	1931353SM	2	CARRIAGE BOLT, 3/8-16 x 1-3/4 G5

Footnotes

The above parts group applies to the following Mfg. Nos.:

2690773 - Baron

Transmission Group - Tuff Torq K664

NOTE: Unless noted otherwise, use the standard hardware torque specification chart.

2987917

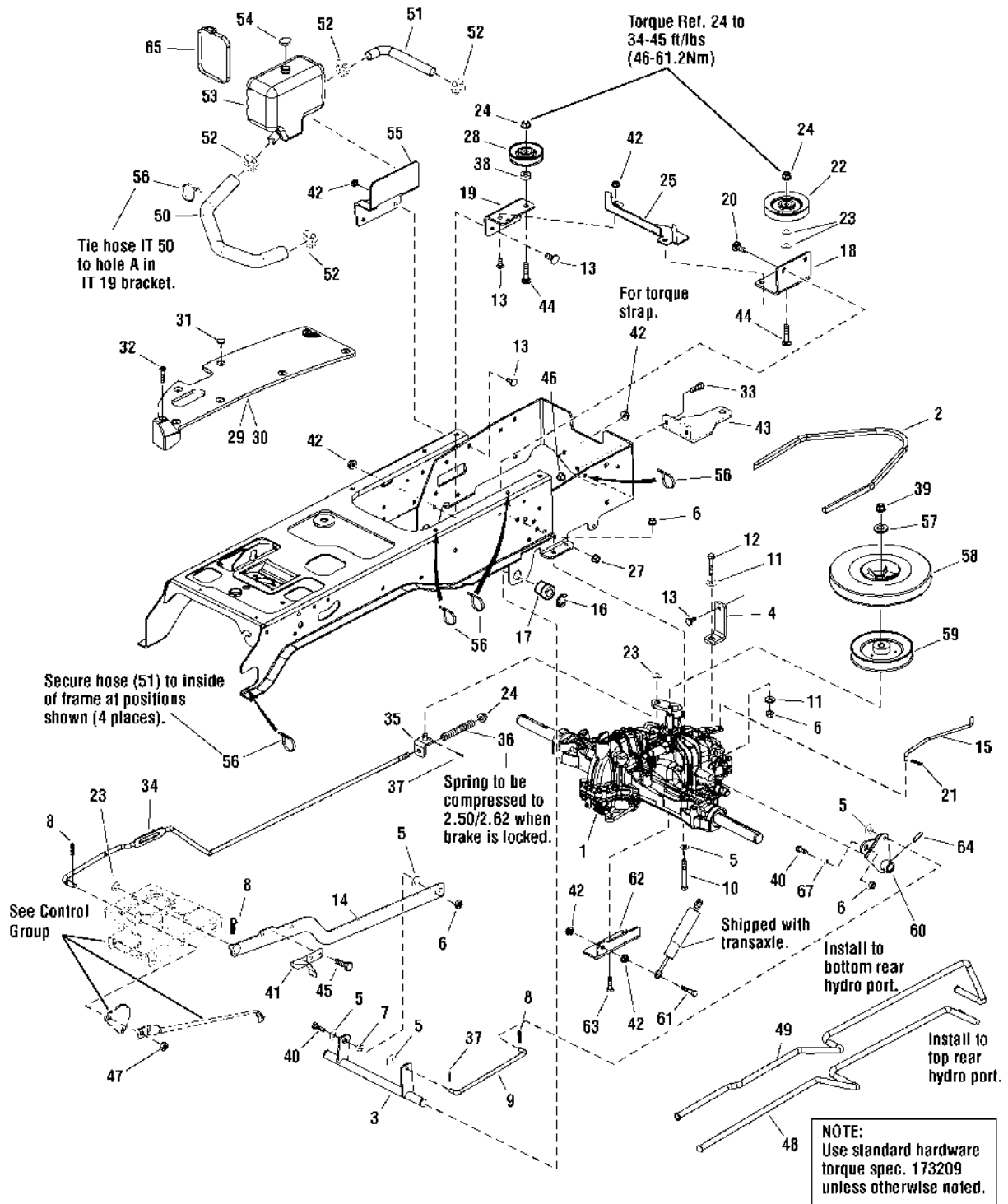

The above parts group applies to the following Mfg. Nos.:

2690773 - Baron

Transmission Group - Tuff Torq K664

REF NO	PART NO.	QTY.	DESCRIPTION
45	1924856SM	2	CAPSCREW, Hex Washer Head Taptite, 5/16-18 x 1/2
46	1928352SM	2	NUT, Hex Flange, 3/8-16 Whiz Lock Large
47	1960103SM	1	WASHER, 3/8
48	1735081SM	1	TUBE, Hydro, Front-Outside
49	1735082SM	1	TUBE, Hydro, Rear-Inside
50	1735558SM	1	HOSE, Tank (To Transmission)
51	1735097SM	1	HOSE, Return
52	1723214SM	4	CLAMP, Hose
53	1735557YP	1	TANK, Reservoir
54	1722711SM	1	CAP, Tank
55	1735066AYP	1	BRACKET, Tank Support
56	2825094SM	6	TIE, Wire
57	1736019SM	1	SPACER, Fan
58	1735634SM	1	FAN, 9
59	1735636SM	1	PULLEY ASSEMBLY
60	1735568SM	1	ARM ASSEMBLY, Control
61	1921221SM	1	CAPSCREW, Hex 5/16-18 x 1.50
62	1735576ASM	1	BRACKET, Dampener, MTG
63	2860765YP	2	CAPSCREW, THD Cut, M8, 1.25 x 30
64	1736066YP	1	PIN, Drive
65	1679896SM	1	CLAMP, Worm Drive
67	1703900SM	1	SPACER

Not for
Reproduction

Footnotes

The above parts group applies to the following Mfg. Nos.:

2690773 - Baron

Transmission SERVICE PARTS - Tuff Torq K664J

NOTE: Unless noted otherwise,
use the standard hardware torque
specification chart.

1735070

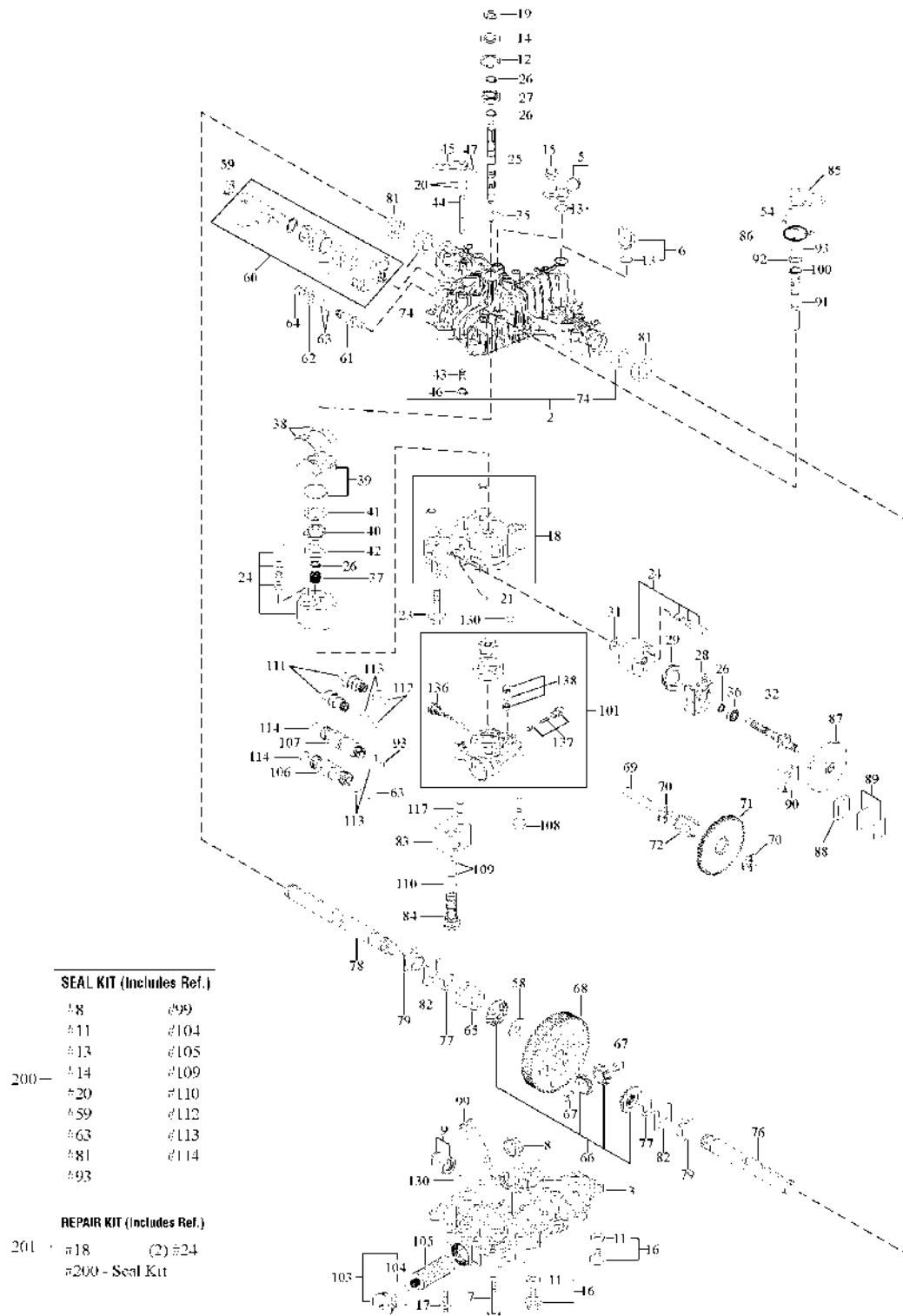

The above parts group applies to the following Mfg. Nos.:

2690773 - Baron

Transmission SERVICE PARTS - Tuff Torq K664J

REF NO	PART NO.	QTY.	DESCRIPTION
1	1735070	1	TRANSAXLE, Tuff Torq K664J
2	-----	1	*KIT, Housing, Upper
3	-----	1	*HOUSING, Lower
5	-----	1	*KIT, Fitting
6	-----	1	*CAP KIT
7	1718226SM	1	CAPSCREW, 8 x 75
8	1720761SM	1	FILTER
9	1718065SM	1	MAGNET, Complete
11	1720796SM	1	WASHER, Seal, 10
12	1708650SM	1	RING, Snap, C 35
13	1707786SM	1	PACKING, P18
14	1708651SM	1	SEAL, TC153507
15	1724695SM	1	BOLT, 8 x 20
16	-----	1	*KIT, Drain Bolt
17	1707789SM	1	SCREW, Tapping, 8 x 30
18	-----	1	*CENTER CASE DB
19	1718076SM	1	E-RING, 15
20	1708691SM	1	PACKING, P10A
21	1718070SM	1	PIN, 3 x 9.8
23	1724698SM	1	BOLT, 10 x 65
24	-----	1	*KIT, Cylinder Block
25	-----	1	*SHAFT, Pump
26	1708672SM	1	RING, Snap, S15
27	1708673SM	1	BEARING
28	-----	1	*HOUSING, Motor
29	1708675SM	1	BEARING, Thrust
31	1718084SM	1	WASHER, 12 x 24 x 1
32	1724701SM	1	MOTOR SHAFT/GEAR (10T)
35	1722223SM	1	PIN, 3 x 13.8
36	1724702SM	1	BEARING, 6302DUC3
37	1708669SM	1	SPRING, Pump
38	1708677SM	1	BEARING, Thrust
39	-----	1	*SWASH PLATE
40	1718237SM	1	BEARING, K81106
41	-----	1	*THRUST PLATE A
42	1718239SM	1	THRUST PLATE B
43	-----	1	*SPRING, 25
44	-----	1	*SHAFT, Bypass
45	1720418SM	1	LEVER, Bypass
46	1718061SM	1	RING, Snap, 10
47	-----	1	*SPRING PIN 3.0A x 20
48	1718039SM	1	SHOCK ABSORBER, K65
49	1724704SM	1	STAY
50	1724705SM	1	PIN

Footnotes

*Note: See your local authorized dealership for parts and warranty or contact Tuff Torq at www.tufftorqservices.com (U.S. 1-866-572-3441 Int'l 01-423-585-1977)

The above parts group applies to the following Mfg. Nos.:

2690773 - Baron

Transmission SERVICE PARTS - Tuff Torq K664J

NOTE: Unless noted otherwise,
use the standard hardware torque
specification chart.

1735070

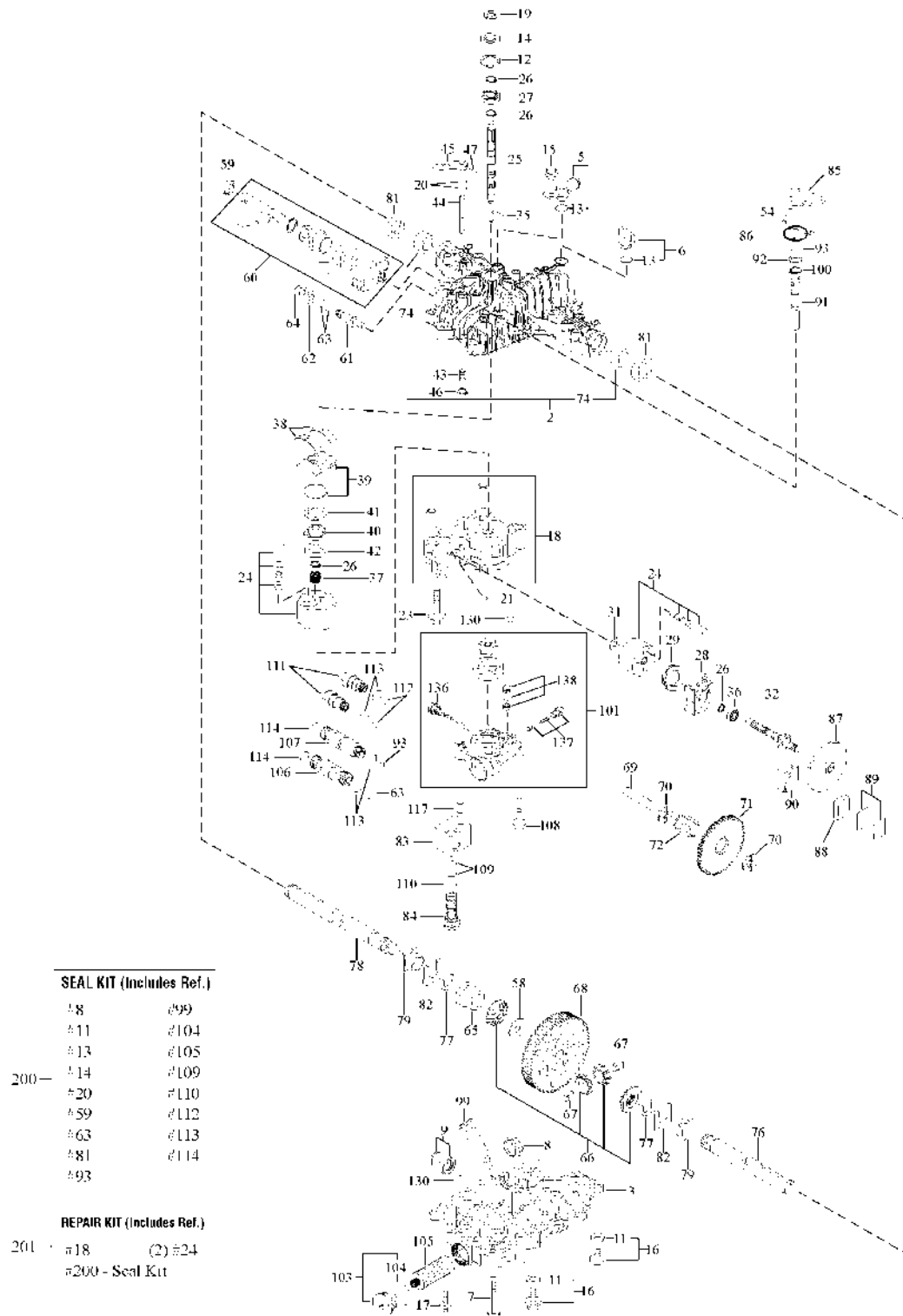

The above parts group applies to the following Mfg. Nos.:

2690773 - Baron

Transmission SERVICE PARTS - Tuff Torq K664J

REF NO	PART NO.	QTY.	DESCRIPTION
51	1724706SM	1	CONTROL LEVER A
54	1718100SM	1	PIN, Roll, 6 x 40
58	-----	1	*WASHER, 17 x 36 x 6.4
59	1718120SM	1	SEAL, TC162606
60	-----	1	*KIT, Control Shaft
61	1721184SM	1	FULCRUM
62	1708689SM	1	WASHER, 12
63	1707879SM	1	PACKING, P14
64	1708692SM	1	NUT 12
65	-----	1	*COLLAR 25.4
66	-----	1	*KIT, Differential Gear
67	-----	1	*PIN, Differential Pinion
68	-----	1	*GEAR, Final
69	-----	1	*SHAFT, Final Pinion
70	1724715SM	1	WASHER, 15 x 35 x 3.2
71	1724716SM	1	GEAR, Reduction
72	1724717SM	1	PINION, Final
74	1724693SM	1	BUSHING, 25.4
76	-----	1	*SHAFT, Axle, Left
77	1720859SM	1	RING, Retaining, 23
78	1724719SM	1	SHAFT, Axle, Right
79	1720860SM	1	BUSHING, 25.4
81	1718264SM	1	SEAL, S25.4 x 42 x 8
82	1720858SM	1	WASHER, Thrust
83	-----	1	*PIPING BLOCK
84	-----	1	*CONNECTOR
85	-----	1	*LEVER, Brake
86	-----	1	*SPRING, Brake Return
87	1724723SM	1	DISK, Brake
88	-----	1	*SHOE, Brake
89	1724725SM	1	KIT, Shim
90	1724726SM	1	BRAKE ACTUATOR
91	-----	1	*SHAFT, Brake
92	1724728SM	1	WASHER, 16 x 23 x 1.6
93	1708690SM	1	PACKING, P12
99	-----	1	*SEALANT
100	1707912SM	1	RING, Snap
101	-----	1	*KIT, Pump Case
103	-----	1	*CAP KIT
104	-----	1	*O-RING, 1A 24040
105	1736211SM	1	FILTER
106	-----	1	*PIPING C
107	-----	1	*PIPING D
108	1720833SM	1	BOLT, 8 x 45
109	-----	1	*PACKING, P12A

Footnotes

*Note: See your local authorized dealership for parts and warranty or contact Tuff Torq at www.tufftorqservices.com (U.S. 1-866-572-3441 Int'l 01-423-585-1977)

The above parts group applies to the following Mfg. Nos.:

2690773 - Baron

Transmission SERVICE PARTS - Tuff Torq K664J

NOTE: Unless noted otherwise,
use the standard hardware torque
specification chart.

1735070

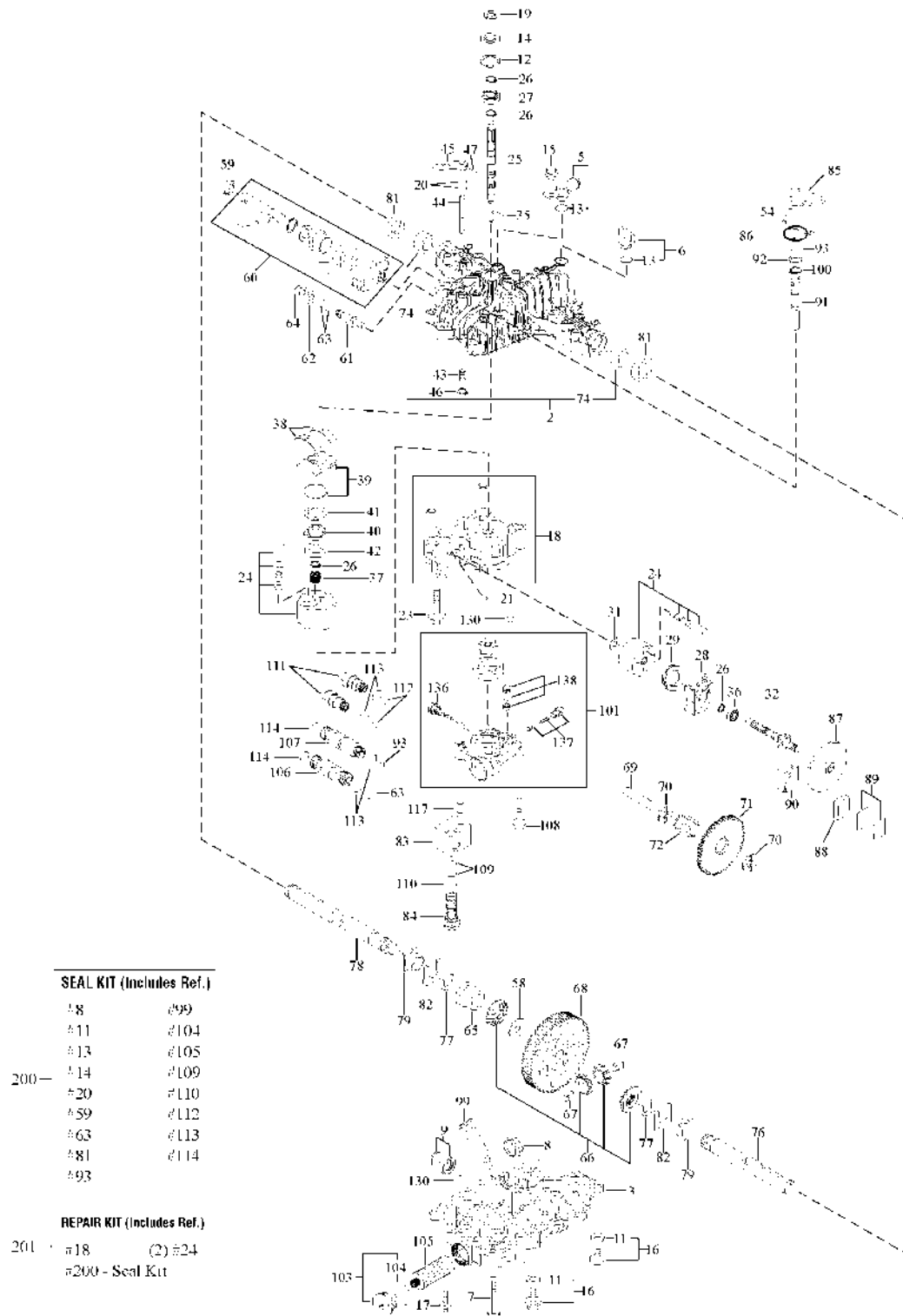

The above parts group applies to the following Mfg. Nos.:

2690773 - Baron

Transmission SERVICE PARTS - Tuff Torq K664J

REF NO	PART NO.	QTY.	DESCRIPTION
110	-----	1	*O-RING P14.0
111	1720829SM	1	CONNECTOR
112	1720831SM	1	PACKING, 6.1
113	1707785SM	1	PACKING, P16
114	-----	1	*O-RING (ORFS)
130	-----	1	*ALIGNMENT SLEEVE 11 x 7
136	-----	1	*VALVE, Charge Relief
137	-----	1	*VALVE, Implement Relief
138	-----	1	*3RD CHECK VALVE
200	-----	1	*SEAL KIT (K664C & K664J) (Used on K664C & K664J)
201	-----	1	*KIT, Repair

Not for
Reproduction

Footnotes

*Note: See your local authorized dealership for parts and warranty or contact Tuff Torq at www.tufftorqservices.com (U.S. 1-866-572-3441 Int'l 01-423-585-1977)

The above parts group applies to the following Mfg. Nos.:

2690773 - Baron

Control Group - Cruise Control

986814

NOTE: Unless noted otherwise,
use the standard hardware torque
specification chart.

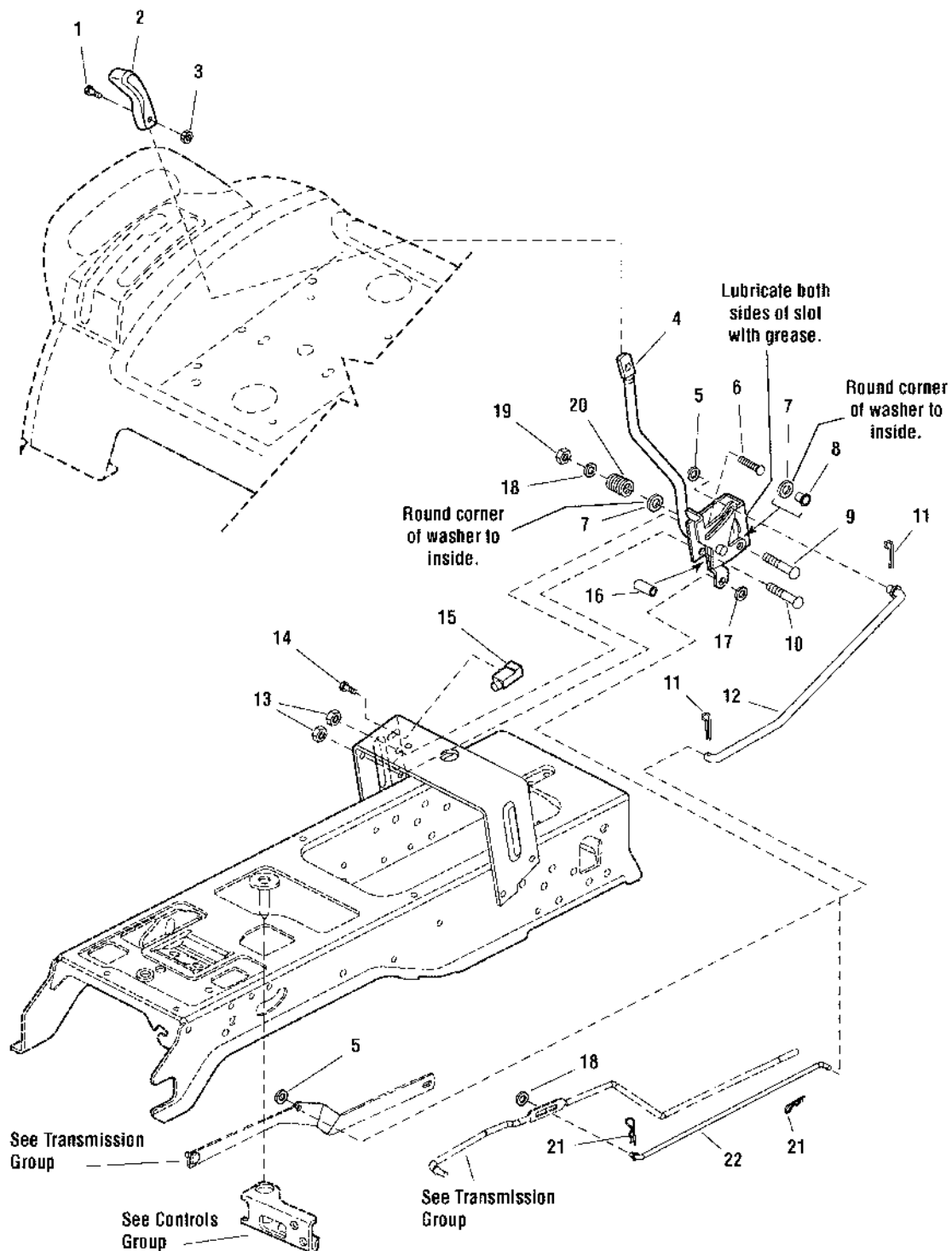

The above parts group applies to the following Mfg. Nos.:

2690773 - Baron

Control Group - Cruise Control

REF NO	PART NO.	QTY.	DESCRIPTION
1	1960666SM	1	CAPSCREW, Torx Socket Head, 1/4-20 x 7/8
2	1722303SM	1	KNOB, Cruise
3	1920397SM	1	NUT, Hex ESNA Lock, 1/4-20
4	1723258SM	1	LEVER & BRACKET ASSEMBLY, Cruise
5	1960103SM	3	WASHER
6	1931333SM	1	CARRIAGE BOLT, 5/16-18 x 3/4
7	1926192SM	2	WASHER, 9/16 x 1-1/4 x 1/8
8	1709043SM	1	SPACER
9	1931342SM	1	CARRIAGE BOLT, 5/16-18 x 2-3/4
10	1960273SM	1	CARRIAGE BOLT, 5/16-18 x 2-1/4
11	1918447SM	2	PIN, Cotter
12	1726059SM	1	ROD, Cruise
13	1960636SM	2	NUT, Hex KEPS, 5/16-18
14	1960001SM	2	CAPSCREW, Hex Head Plastite, 10-14 x 5/8
15	1717050SM	1	SWITCH, Push, Neutral Start, Gray
16	1722080SM	1	SPACER
17	1919326SM	1	WASHER
18	1919381SM	2	WASHER
19	1919438SM	1	NUT, Hex ESNA Lock, 5/16-18
20	1677746SM	1	SPRING, Compression
21	1722460SM	2	PIN, Quick
22	1723099SM	1	ROD, Cruise Return

Not for
Reproduction

Footnotes

The above parts group applies to the following Mfg. Nos.:

2690773 - Baron

Controls Group

987595

NOTE: Unless noted otherwise,
use the standard hardware torque
specification chart.

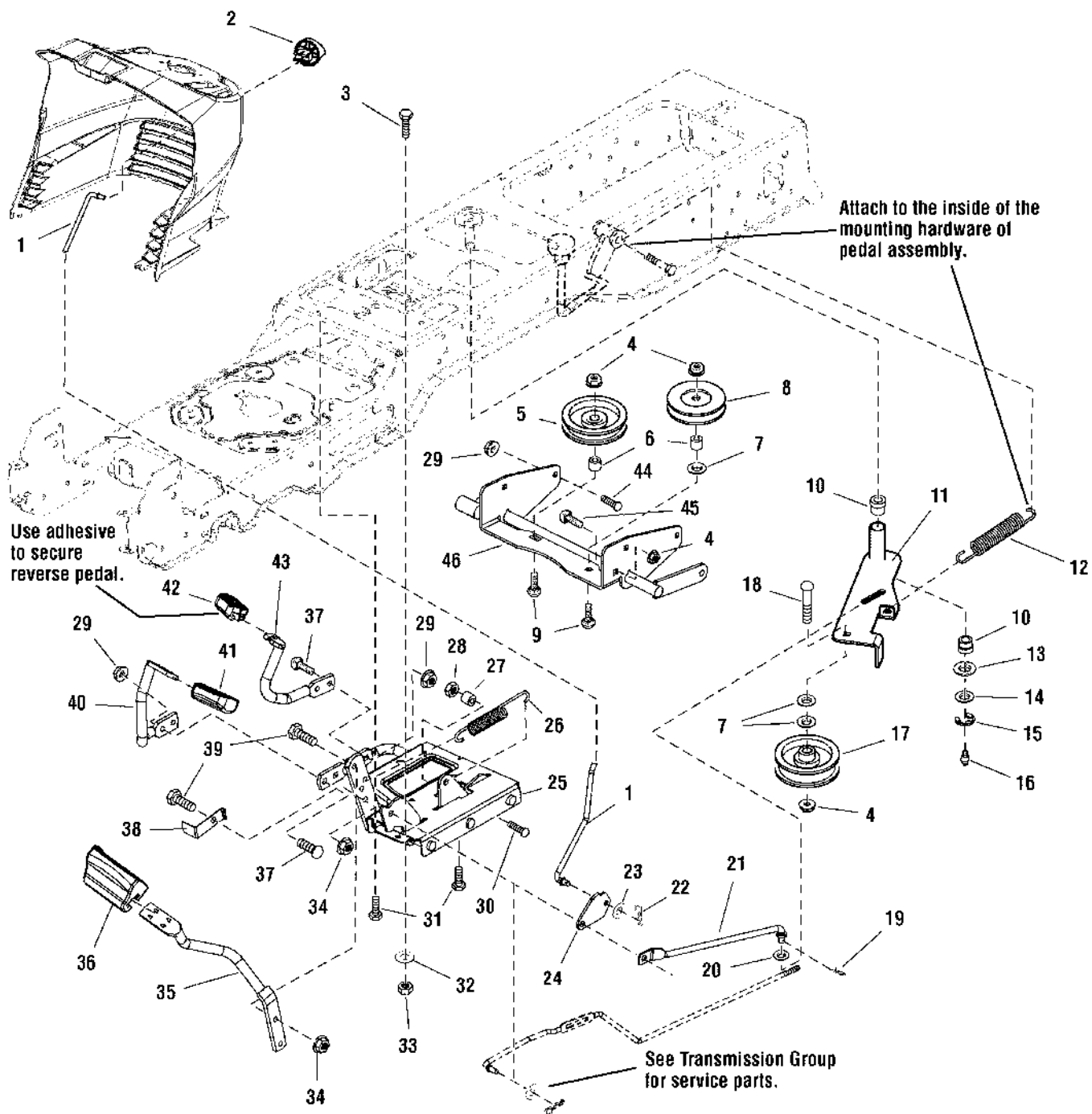

The above parts group applies to the following Mfg. Nos.:

2690773 - Baron

Controls Group

REF NO	PART NO.	QTY.	DESCRIPTION
1	1721353SM	1	ROD, Brake
2	1721891SM	1	KNOB, Push On, Red
3	1930591SM	1	CAPSCREW, Hex Head Flange Lock, 5/16-18 x 3/4
4	1960687SM	3	NUT, Hex Flange, 3/8-16 ESNA
5	1721134SM	1	PULLEY ASSEMBLY, 3 OD, W/Bearing
6	1667811SM	2	SPACER
7	1922755SM	3	WASHER, 3/8
8	1710545SM	1	PULLEY, Idler 4 OD
9	1960315SM	2	CARRIAGE BOLT, 3/8-16 x 2 G5
10	1663114SM	2	BUSHING
11	1727370SM	1	ARM & HUB ASSEMBLY, Idler
12	1733844SM	1	SPRING, Extension
13	1960020SM	1	WASHER, 5/8
14	1924366SM	1	WASHER, 5/8
15	1704420SM	1	RING, Clipping
16	1704314SM	1	FITTING, Lube, 1/4 Ball Check
17	1710539SM	1	PULLEY, Idler 3-1/4 OD
18	1960315SM	1	CARRIAGE BOLT, 3/8-16 x 2 G5
19	1918447SM	1	PIN, Cotter
20	1924940SM	1	WASHER
21	1727408SM	1	ROD, Brake (Flat Ends)
22	1722460SM	1	PIN, Quick
23	1919326SM	1	WASHER
24	1721354ASM	1	LATCH, Brake
25	1726763SM	1	CONTROL ASSEMBLY, Foot Pedal
26	1721995SM	1	SPRING, Extension
27	1686612SM	1	CAM, Roller
28	1920397SM	1	NUT, Hex Lock ESNA, 1/4-20
29	1960636SM	8	NUT, Hex KEPS, 5/16-18
30	1931320SM	1	CARRIAGE BOLT, 1/4-20 x 1-1/4
31	1664847SM	3	CAPSCREW, Hex head Washer Taptite, 5/16-18 x 3/4
32	1919381SM	1	WASHER
33	1919438SM	1	NUT, Hex Lock ESNA, 5/16-18
34	1927557SM	3	NUT, Hex Flange Lock, 5/16-18
35	1722535ASM	1	PEDAL, Brake
36	1721577SM	1	PAD, Brake Pedal
37	1931334SM	4	CARRIAGE BOLT, 5/16-18 x 7/8
38	1722083ASM	1	ACTUATOR, Switch
39	1921333SM	3	CAPSCREW, Hex Head, 5/16-18 x 1
40	1722070ASM	1	PEDAL, Forward
41	1721675SM	1	PAD, Foot Pedal Forward
42	1721674SM	1	PAD, Foot Pedal Reverse
43	1722071ASM	1	PEDAL, Reverse
44	1931333SM	4	CARRIAGE BOLT, 5/16-18 x 3/4

Footnotes

The above parts group applies to the following Mfg. Nos.:

2690773 - Baron

Controls Group

987595

NOTE: Unless noted otherwise,
use the standard hardware torque
specification chart.

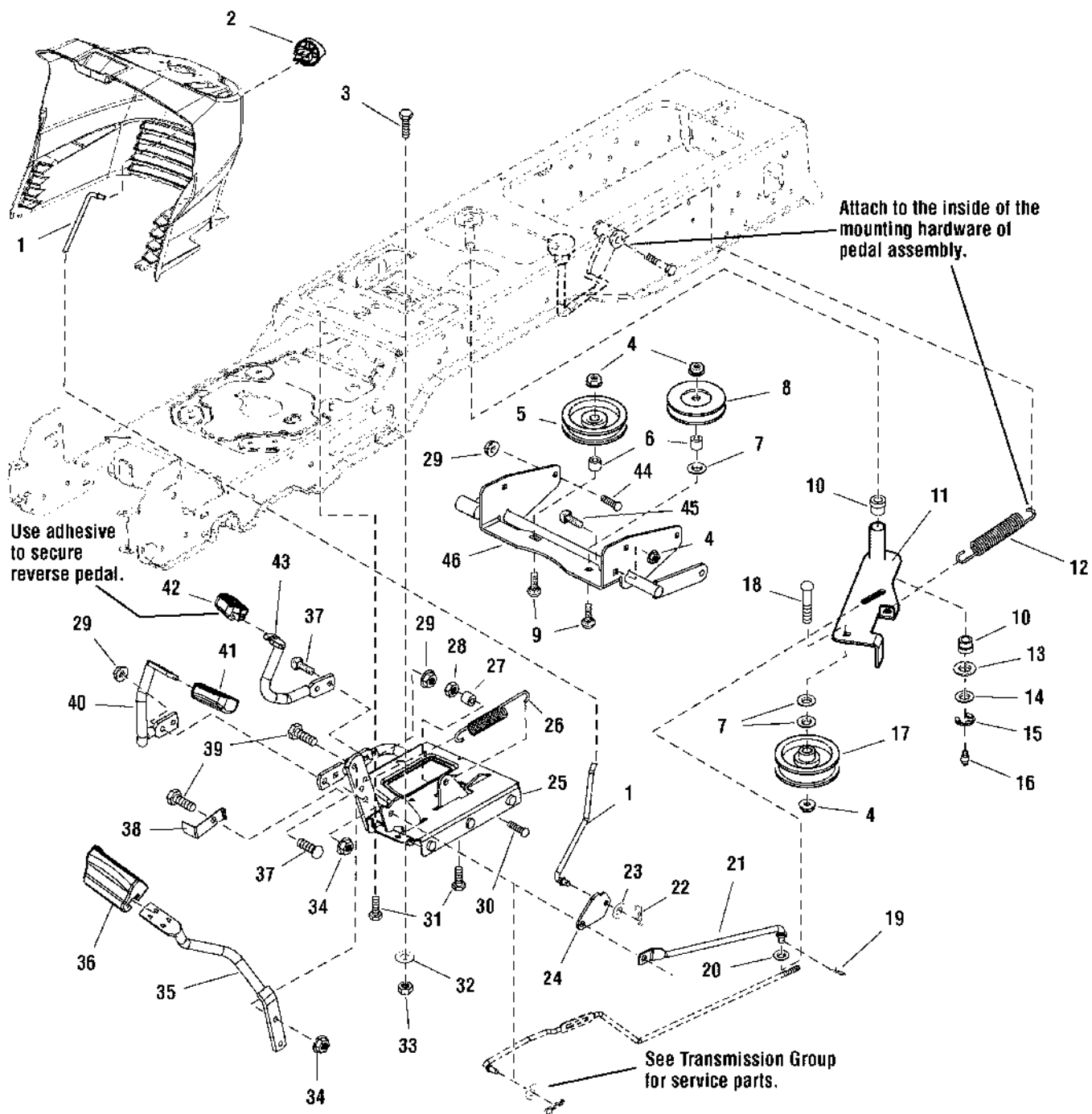

The above parts group applies to the following Mfg. Nos.:

2690773 - Baron

Controls Group

REF NO	PART NO.	QTY.	DESCRIPTION
45	1931348SM	1	CARRIAGE BOLT, 3/8-16 x 3/4
46	1726087ASM	1	SUPPORT, Idler

Not for
Reproduction

Footnotes

The above parts group applies to the following Mfg. Nos.:

2690773 - Baron

Electrical Group

986631

NOTE: Unless noted otherwise, use the standard hardware torque specification chart.

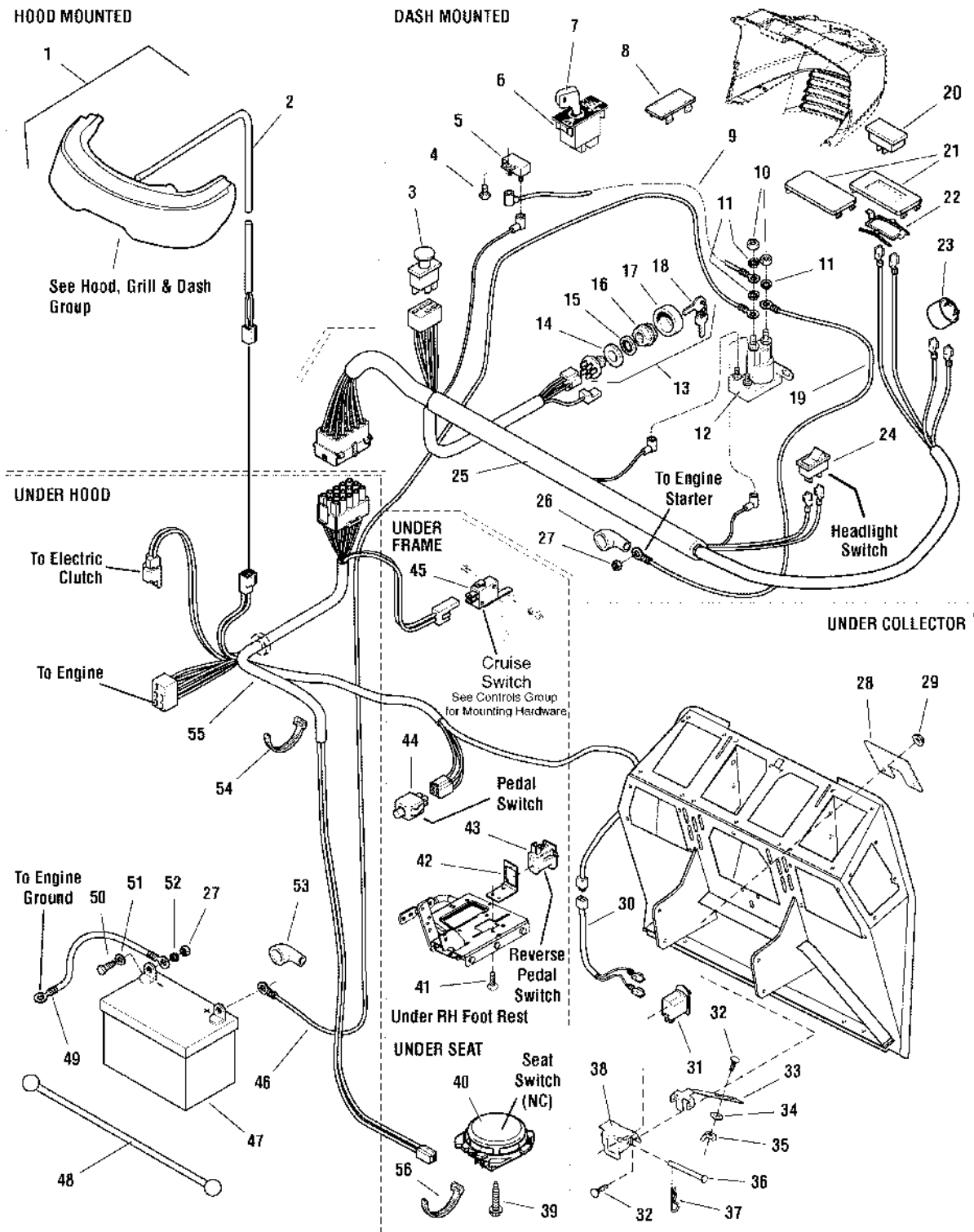

The above parts group applies to the following Mfg. Nos.:

2690773 - Baron

Electrical Group

REF NO	PART NO.	QTY.	DESCRIPTION
1	1721810SM	1	HEADLIGHT ASSEMBLY, 4 Bulb
2	1722669SM	1	HARNESS, Headlight
3	1722887SM	1	SWITCH, PTO Push/Pull w/Symbols
4	1921959SM	1	CAPSCREW, Hex Head, 1/4 x 5/8
5	1722739SM	1	SOLENOID
6	1726556SM	1	SWITCH, RMO Module Only
7	1726557SM	1	KEY, RMO Module, Plastic
8	1722611SM	1	PLUG, Hole Black
9	1665237SM	1	WIRE, 12GA 8 Long Red
10	2820263SM	2	NUT, Hex, 5/16-24 NF-2B
11	2820426SM	3	LOCKWASHER, External Tooth 5/16
12	1665238SM	1	BREAKER, Circuit 12VOLT 20AMPS w/Tabs
13	1686734SM	1	SWITCH ASSEMBLY, Ingition, 6 Pin Indak (Includes Ref. Nos. 14 thru 18)
14	2101025SM	1	WASHER, 5/8
15	1960547SM	1	LOCKWASHER, Internal Tooth, 5/8
16	1717549SM	1	NUT, Hex Flange, 5/8-32 Ignition Switch
17	1717550SM	1	COVER, Ignition Switch, Black
18	1717163SM	1	KEYS, Ignition Set of 2
19	1721830SM	1	CABLE, # 6 x 25 Long Red, 2 Ring Terminals
20	1731184SM	1	METER, Hour Digital w/Oil & Lube Alarms
21	1725524SM	1	PLUG, Dash, Hour Meter
21	1725698SM	1	PLUG, Dash, No Hour Meter Hole
22	1725835SM	1	CLIP, Hour Meter, Holds In Daash
23	1720117SM	1	BUZZER, Pulse, Grass Bag Full
24	1716951SM	1	SWITCH, Headlights, 2 Terminal
25	1730195SM	1	HARNESS, Wiring Upper
26	1677296SM	1	BOOT, Insulator, Battery Terminal
27	2816622SM	3	NUT, Hex, 1/4-20 NC-2B
28	1727776ASM	1	DEFLECTOR, Switch 14GA
29	1960685SM	2	NUT, Hex KEPS Conical Washer, 1/4-20
30	1723954SM	1	HARNESS, Wiring Rear
31	1720411SM	1	SWITCH, Push Button w/Boot, Bagger
32	1960252SM	3	CARRIAGE BOLT, 1/4-20 x 5/8 G5
33	1727428SM	1	PIVOT, Actuator 14GA, E-Coat
34	1960103SM	1	WASHER, 3/8
35	2860293SM	1	NUT, Wing Lock, 1/4-20
36	1960607SM	1	PIN, Clevis
37	1960221SM	1	CLIP, Hair Pin
38	1727427SM	1	SUPPORT, Actuator 14GA, E-Coat
39	1960536SM	2	SCREW, Hex Washer Head Plastite, 1/4 x 1/2 (Used only on Seat Switch 1716368SM)
40	1716368SM	1	SWITCH, Operator Presents, Seat (Mounted with screw Syte)
40	1718981SM	1	SWITCH, Operator Presents, Seat (Twist in Style)
41	1929000SM	1	SCREW, Hex Washer Head Taptite, 1/4-20 x 3/8

Footnotes

The above parts group applies to the following Mfg. Nos.:

2690773 - Baron

Electrical Group

986631

NOTE: Unless noted otherwise, use the standard hardware torque specification chart.

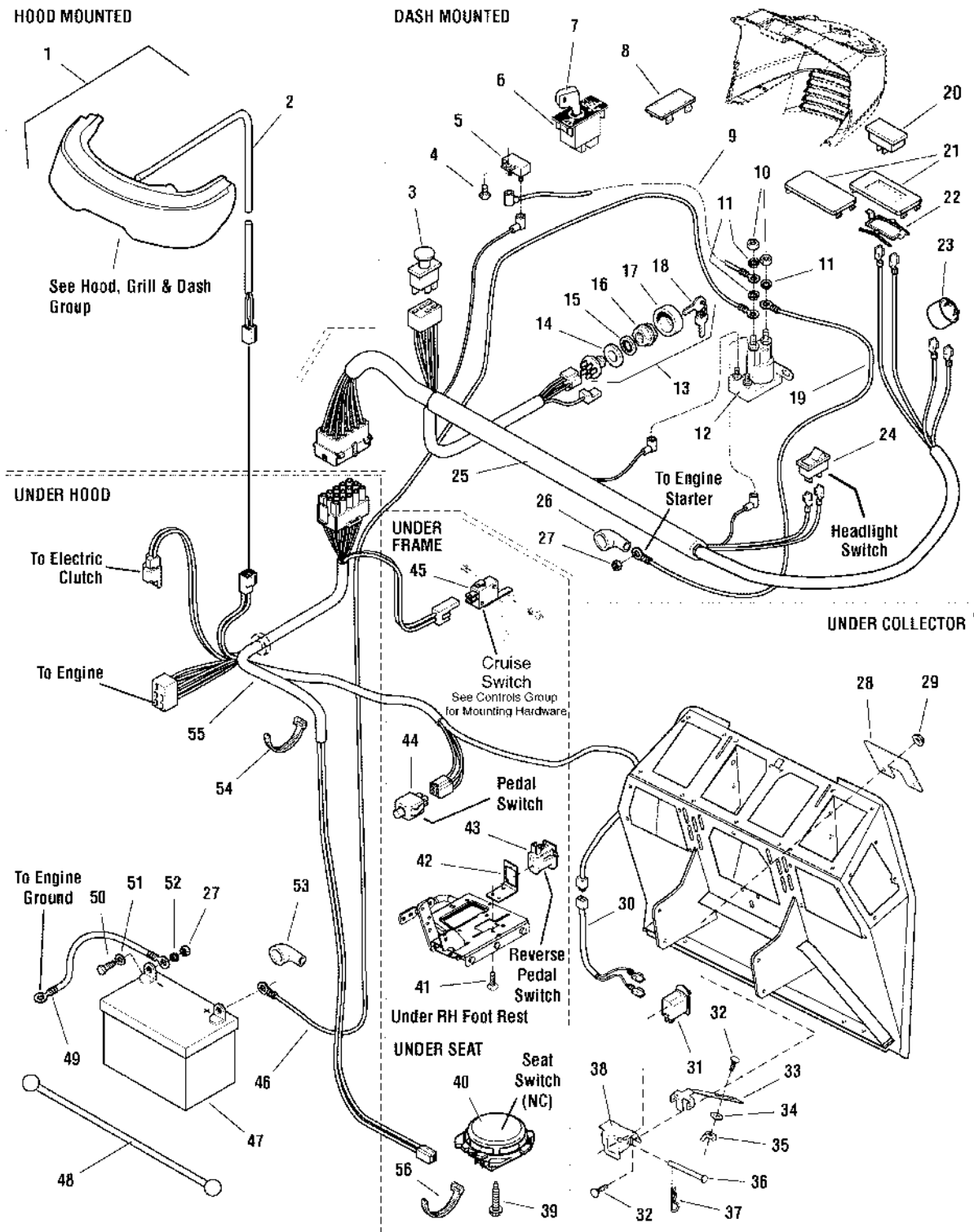

The above parts group applies to the following Mfg. Nos.:

2690773 - Baron

Electrical Group

REF NO	PART NO.	QTY.	DESCRIPTION
42	1726810ASM	1	BRACKET, Switch Mounting, RMO
43	1732004SM	2	SWITCH, Push Button, Reverse Pedal
44	1723507SM	1	SWITCH, Push Button, Foot Pedal
45	1717050SM	1	SWITCH, Push Button, Cruise Control
46	1603618SM	1	CABLE, # 6 x 9 Long, 2 Ring Terminals
47	1685215SM	1	BATTERY, 12VOLT 6CELL 230AMPS CCA
48	1722009SM	1	STRAP, Battery 14 Long, Black Rubber
49	1713163SM	1	CABLE, # 6 x 26 Long Black, 2 Ring Terminals
50	2823341SM	2	CAPSCREW, Hex Head, 1/4-20 x 3/4 G5
51	2821319SM	2	WASHER, 1/4
52	2816964SM	2	LOCKWASHER, Spring 1/4
53	1713535SM	1	BOOT, Insulator Red, Cable Terminal
54	1701011SM	4	TIE, Self Locking, 7-5/16
55	1730194SM	1	HARNESS, Wiring Lower
56	2825094SM	1	TIE, Self Locking (Used only on Seat Switch 1718981SM)

Not for
Reproduction

Footnotes

The above parts group applies to the following Mfg. Nos.:

2690773 - Baron

Hood, Grille & Dash Group

986611

NOTE: Unless noted otherwise,
use the standard hardware torque
specification chart.

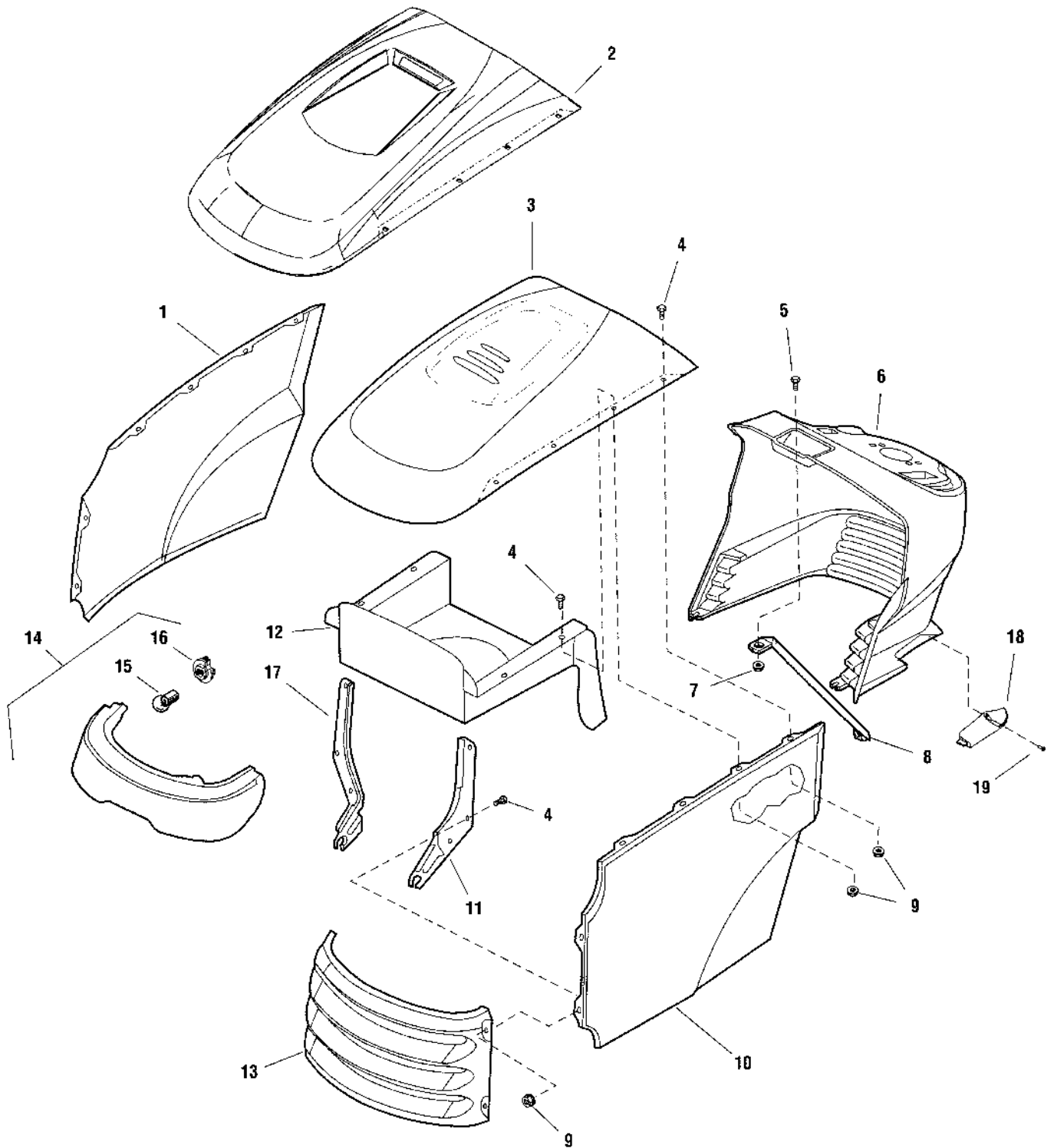

The above parts group applies to the following Mfg. Nos.:

2690773 - Baron

Hood, Grille & Dash Group

REF NO	PART NO.	QTY.	DESCRIPTION
1	1721804CSM	1	PANEL, RH Side
1	1721804DSM	1	PANEL, RH Side, Red
2	1728031DSM	1	HOOD, with Scoop
3	1722110CSM	1	HOOD, with Louvers
4	1960295SM	12	CAPSCREW, Hex Head Flange Lock, 1/4-20 x 5/8
5	1960392SM	1	SCREW, Phillips Head, #10-24 x 1/2
6	1687056SM	1	DASHBOARD, RMO with Buzzer Hole, Black
7	1933896SM	1	NUT, Hex Nylock, #10-24
8	1723123SM	1	ROD, Dash Support
9	1930641SM	12	NUT, Hex Flange Lock, 1/4-20
10	1721803CSM	1	PANEL, LH Side
10	1721803DSM	1	PANEL, LH Side, Red
11	1721808ASM	1	HINGE, LH
12	1733457ASM	1	DUCT, Air Inlet
13	1721802CSM	1	GRILLE
13	1721802DSM	1	GRILLE, Red
14	1721810SM	1	HEADLIGHT ASSEMBLY, (Includes Ref. Nos. 15 & 16)
15	1677371SM	4	BULB, Headligh
16	1723451SM	4	SOCKET, Headlight
17	1721809ASM	1	HINGE, RH
18	1722285SM	1	COVER, Lift
19	1722607SM	1	SCREW, Plastite #8-16 x 1/2

Not for
Reproduction

Footnotes

The above parts group applies to the following Mfg. Nos.:

2690773 - Baron

Seat Deck & Fuel Tank Group

986812

NOTE: Unless noted otherwise,
use the standard hardware torque
specification chart.

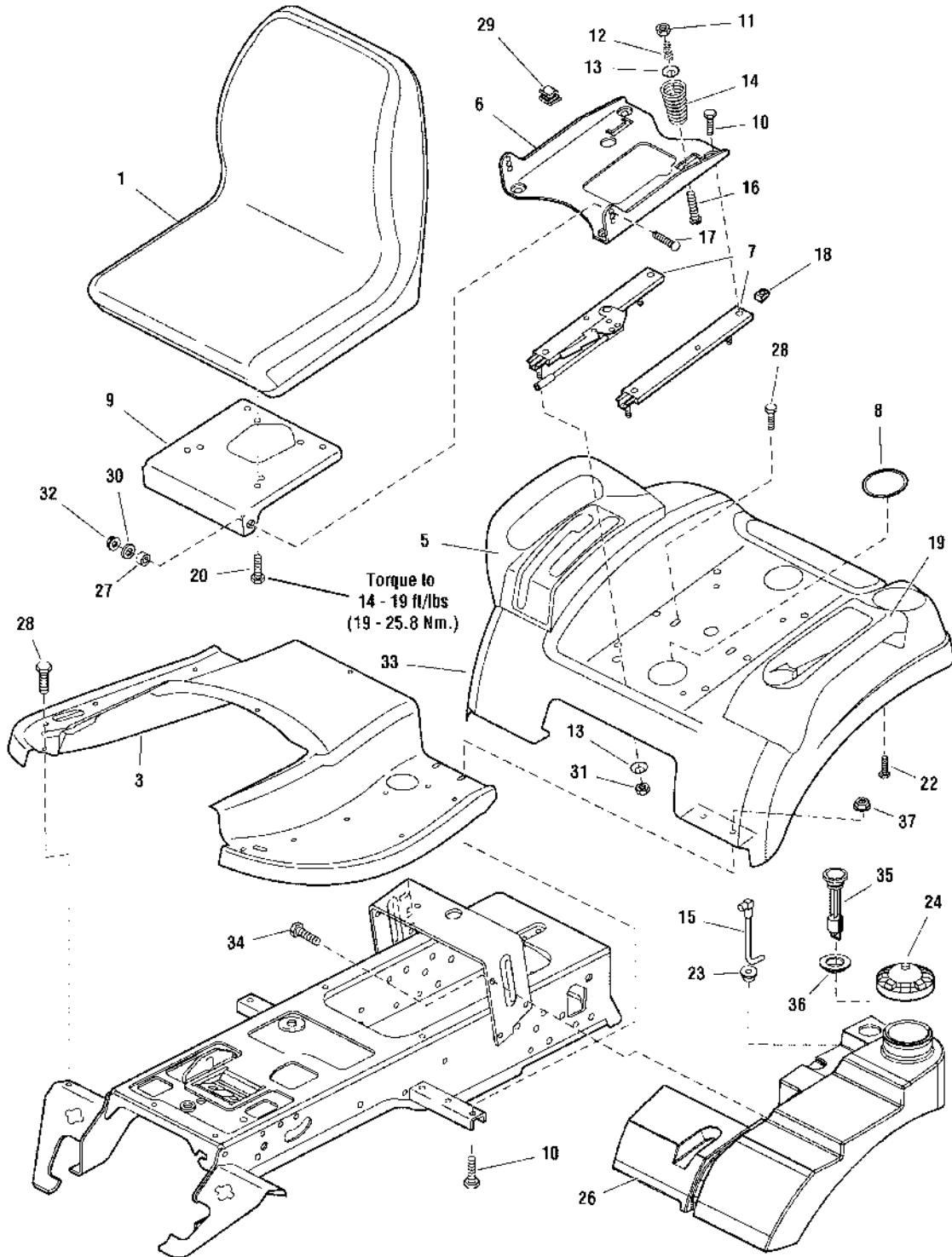

The above parts group applies to the following Mfg. Nos.:

2690773 - Baron

Seat Deck & Fuel Tank Group

REF NO	PART NO.	QTY.	DESCRIPTION
1	1687201SM	1	SEAT, 15" Back
3	1722105CSM	1	TUNNEL, Orange
3	1722105DSM	1	TUNNEL, Red
5	1722108SM	1	POD, R.H.
6	1722128ASM	1	SUPPORT, Seat
7	1722356SM	1	SLIDE, Seat
8	1722309SM	2	PLUG, Hole
9	1722129ASM	1	BRACKET, Seat
10	1930591SM	8	SCREW, Hex Whiz Lock Flange 5/16-18 x 3/4
11	1919438SM	2	NUT, Hex Lock Esna Light 5/16-18
12	1714263SM	2	SPRING, Compression
13	1709256SM	6	WASHER, Spring
14	1717051SM	2	SPRING
15	1726902SM	1	TUBE & ELBOW ASSEMBLY, Fuel Line w/Screen
16	1931339SM	2	CARRIAGE BOLT, 5/16-18 x 2 G5
17	1931350SM	2	CARRIAGE BOLT, 3/8-16 x 1 G5
18	1935255SM	4	NUT, Speed, 5/16-18 Lug Type
19	1729711SM	1	POD, w/Cup Holder
20	1960667SM	4	SCREW, Hex Flange, Whiz Lock 5/16-18 x 1
22	2860664SM	8	SCREW, Hex Sems Washer 1/4c x 7/8
23	1654930SM	1	BUSHING, Fuel TankFUEL TANK
24	1715917SM	1	CAP, Fuel Tank
26	1722652SM	1	TANK, Fuel
27	1663752SM	2	SPACER
28	1930601SM	2	SCREW, Hex Washer Head Taptite 5/16-18 x 5/8
29	2172434SM	1	CLIP, Wire, Panel
30	1924940SM	2	WASHER, 3/8
31	1919438SM	4	NUT, Hex Lock Esna Light 5/16-18
32	1930645SM	2	NUT, Hex Flange 3/8-16 Two-Way Lock
33	1727397CSM	1	DECK, Seat Orange
33	1727397DSM	1	DECK, Seat Red
34	2834665SM	1	SCREW, Hex Whiz Lock Flange 5/16-18 x 5/8
35	1722300SM	1	FUEL, Gauge
36	1722337SM	1	GROMMET
37	1931277SM	4	NUT, Hex Flange 5/16-18 Whiz Lock Small

Footnotes

The above parts group applies to the following Mfg. Nos.:

2690773 - Baron

Hopper Group

986813

NOTE: Unless noted otherwise,
use the standard hardware torque
specification chart.

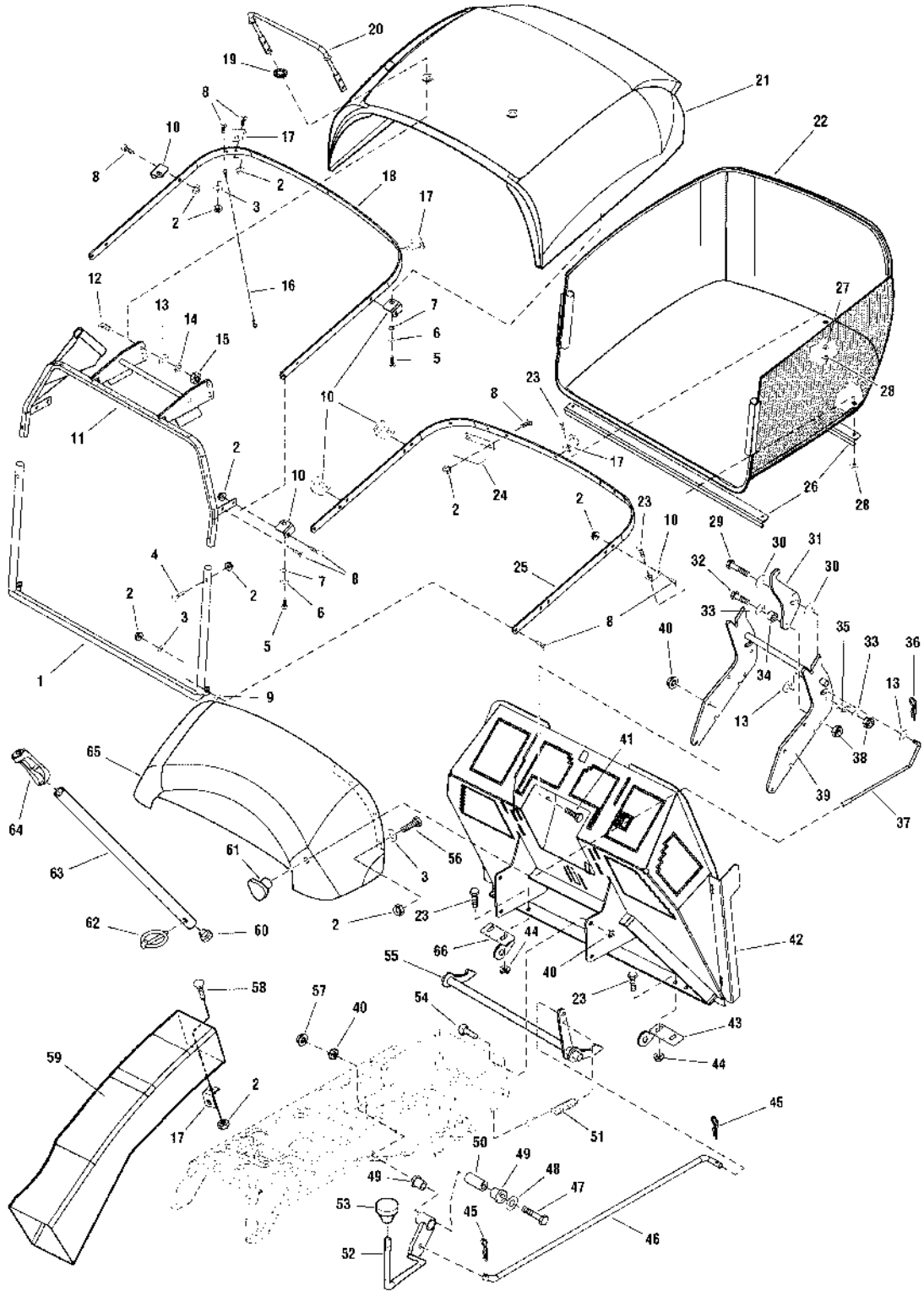

The above parts group applies to the following Mfg. Nos.:

2690773 - Baron

Hopper Group

REF NO	PART NO.	QTY.	DESCRIPTION
1	1727486ASM	1	ROD & TABS ASSEMBLY, Bagger Front
2	1960685SM	22	NUT, Hex KEPS Conical Washer, 1/4-20
3	1960353SM	8	WASHER, 1/4
4	1931320SM	4	CARRIAGE BOLT, 1/4-20 x 1-1/4
5	1921333SM	6	CAPSCREW, Hex Head, 5/16-18 x 1 G5
6	1917356SM	6	LOCKWASHER, Spring 5/16
7	1919326SM	6	WASHER, 5/16
8	1931317SM	15	CARRIAGE BOLT, 1/4-20 x 3/4 G5
9	1715654SM	2	SPACER
10	1727674SM	6	CLIP, L 12GA
11	1727420ASM	1	FRAME ASSEMBLY, Hopper
12	1924009SM	4	CAPSCREW, Hex Head, 1/4-20 x 7/8 G5
13	1921319SM	3	WASHER, 1/4
14	1916964SM	4	LOCKWASHER, Spring 1/4
15	1916622SM	4	NUT, Hex 1/4-20
16	1727832SM	2	CABLE, Bagger, 17.72 Long
17	1727676ASM	4	CLIP, L 12GA
18	1727671ASM	1	BAR, Bagger Top 7GA
19	1724684SM	2	WASHER, 5/8
20	1724399ASM	1	HANDLE, Hopper, 13.59 Long
21	1727930SM	1	LID & SCREEN ASSEMBLY, Orange
21	1727931SM	1	LID & SCREEN ASSEMBLY, Red
22	1727423SM	1	BAG, Grass Black Cloth
23	1931334SM	9	CARRIAGE BOLT, 5/16-18 x 7/8 G5
24	1727520ASM	1	PLATE, Tube Stop Bagger 14GA
25	1727670ASM	1	BAR, Bagger Bottom 7GA
26	1727675ASM	2	BRACE, Angle
27	1960044SM	1	WASHER, 5/16
28	1960684SM	5	NUT, Hex KEPS Conical Washer, 5/16-18
29	1921978SM	1	CAPSCREW, Hex Head 5/16-18 x 2 G5
30	1960044SM	2	WASHER, 5/16
31	1724651ASM	1	LATCH, Release 10GA
32	1921333SM	1	CAPSCREW, Hex Head, 5/16-18 x 1 G5
33	1919326SM	2	WASHER, 5/16
34	1666697SM	1	SPACER, Powdered Metal
35	1714263SM	1	SPRING, Compression
36	1923360SM	1	PIN, Cotter
37	1724652SM	1	ROD, Foot Pedal Bagger Release, 11.66 Long, 2 Bends
38	1919438SM	2	NUT, Hex Lock ESNA Light, 5/16-18 NC-3B
39	1727580ASM	1	PIVOT ASSEMBLY, Latch
40	1928352SM	5	NUT, Hex Flange Whiz Lock, 3/8-16 Large
41	1921965SM	4	CAPSCREW, Hex Head, 3/8-16 x 3/4 G5
42	1727419ASM	1	BACKPLATE ASSEMBLY
43	1723182ASM	1	BRACKET, Latch LH, 7GA

Footnotes

The above parts group applies to the following Mfg. Nos.:

2690773 - Baron

Hopper Group

986813

NOTE: Unless noted otherwise,
use the standard hardware torque
specification chart.

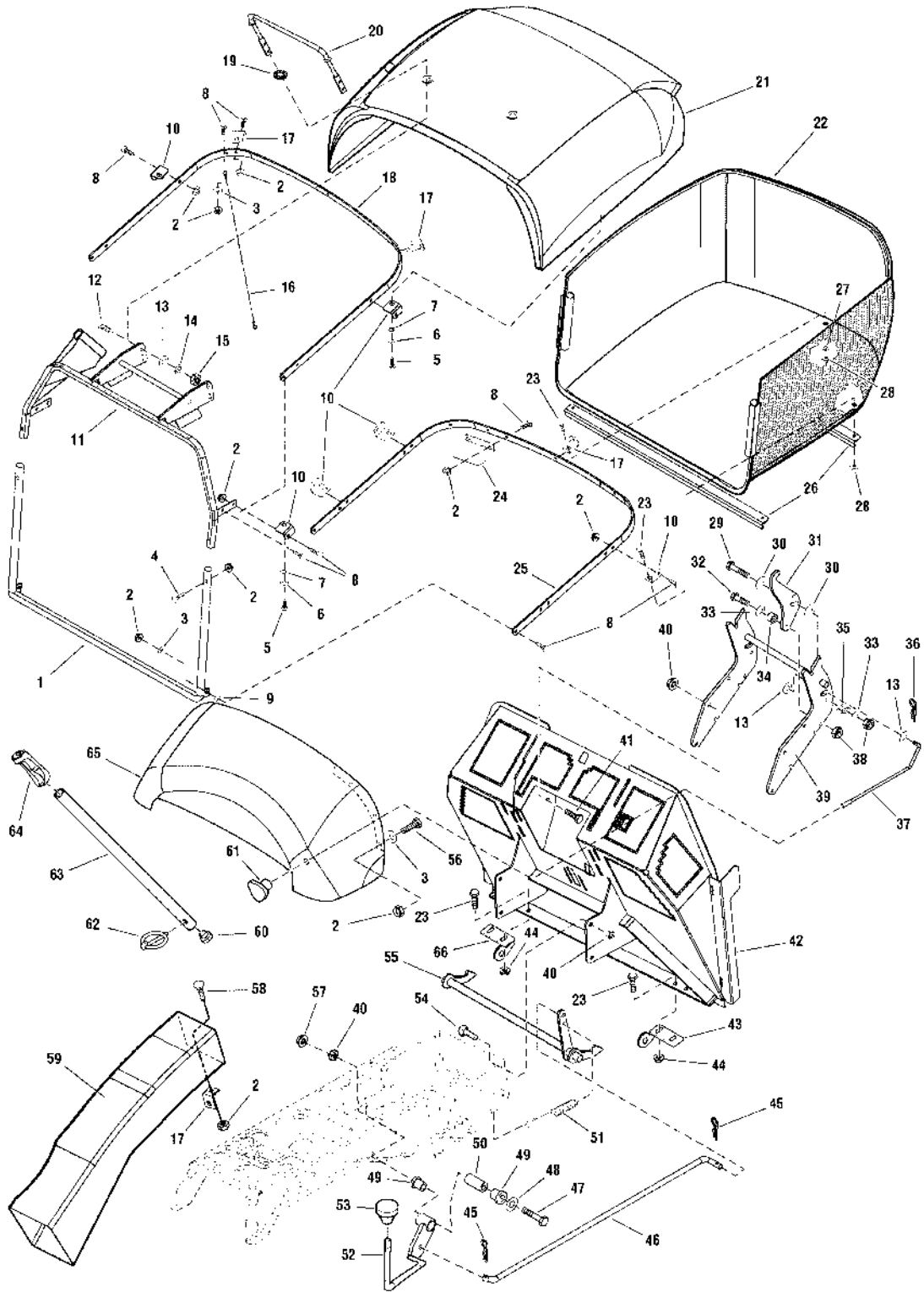

The above parts group applies to the following Mfg. Nos.:

2690773 - Baron

Hopper Group

REF NO	PART NO.	QTY.	DESCRIPTION
44	1931277SM	4	NUT, Hex Flange Whiz Lock, 5/16-18 Small
45	1960074SM	2	CLIP, Hair Pin, Spring Wire
46	1724458SM	1	ROD, 25.12 Long, 2 Bends
47	1921973SM	1	CAPSCREW, Hex Head, 3/8-16 x 2-3/4 G5
48	1924940SM	1	WASHER, 3/8
49	1676148SM	2	BUSHING, Powdered Metal
50	1669105SM	1	SPACER, 1-1/2 Long, Hardened
51	1718016SM	1	SPRING, Extension
52	1725036SM	1	ROD & TUBE ASSEMBLY, Differential Lock Pedal
53	1719940SM	1	KNOB, Hole 1/2, 1.37 Long
54	1960268SM	4	CARRIAGE BOLT, 3/8-16 x 1-1/4 G5
55	1724540SM	1	SHAFT & ARMS ASSEMBLY, Latch
56	1960556SM	4	SCREW, Pan Head Torx Taptite, 1/4-20 x 3/4
57	1930645SM	1	NUT, Hex Flange Two Way Lock, 3/8-16 GA
58	1923341SM	1	CAPSCREW, Hex Head, 1/4-20 x 3/4 G5
59	1727429SM	1	CHUTE, Discharge Black Poly
60	1724553SM	1	CAPLUG, Black Poly, 3/4 Hole
61	1713855SM	1	KNOB, Bagger Release
62	1666969SM	1	PIN, Klik 5/164
63	1727523ASM	1	HANDLE, Tube, 39.75 Long
64	1723359SM	1	GRIP, Hopper Lift Rod
65	1727406SM	1	TRANSITION, Hopper Black
66	1723181ASM	1	BRACKET, Latch RH, 7GA

Not for
Reproduction

Footnotes

The above parts group applies to the following Mfg. Nos.:

2690773 - Baron

Wheels & Tires Group

NOTE: Unless noted otherwise,
use the standard hardware torque
specification chart.

W987920

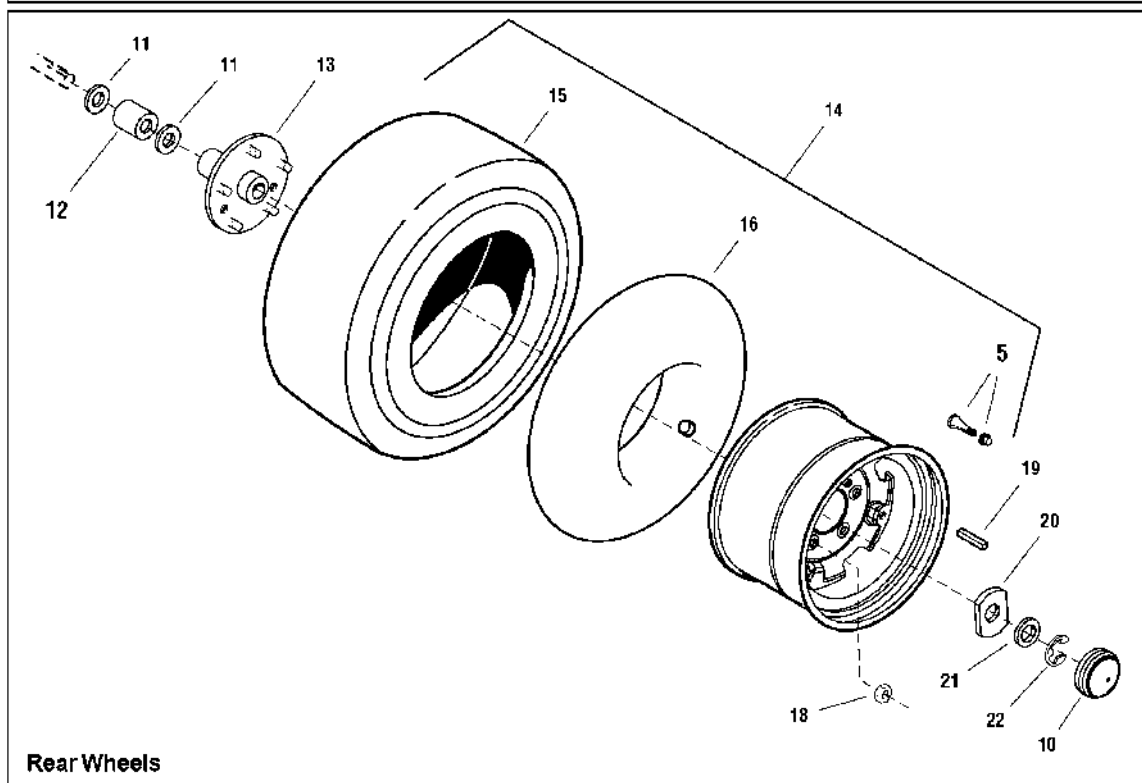
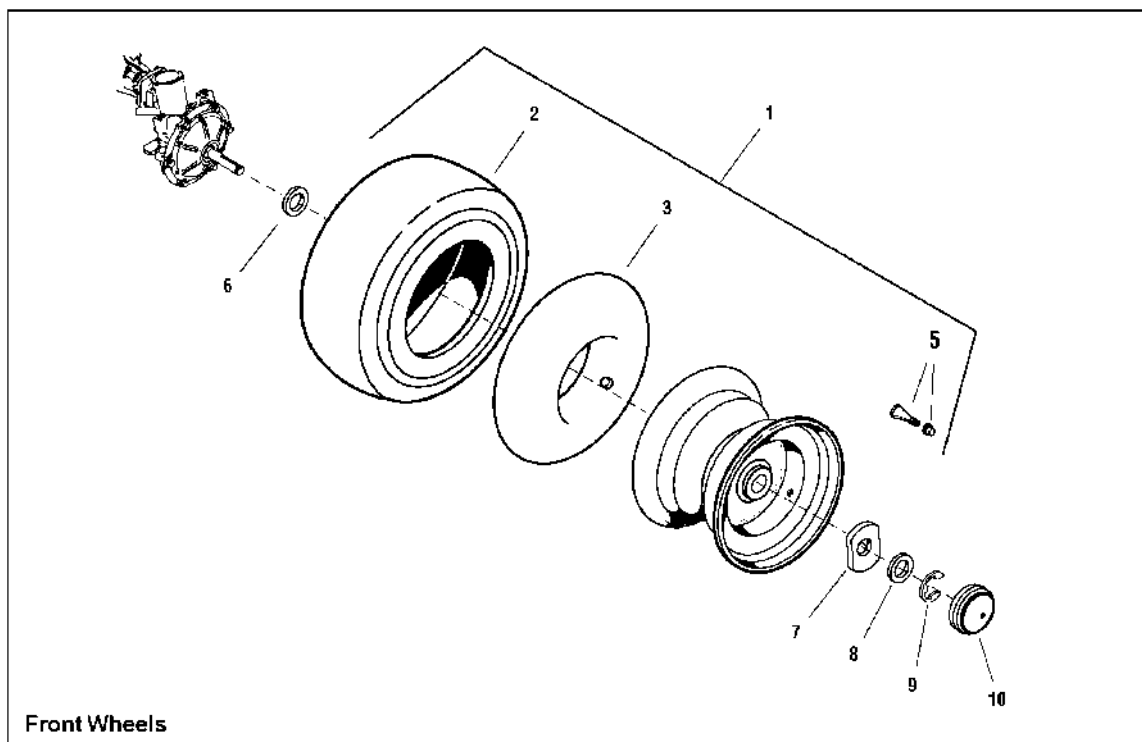

The above parts group applies to the following Mfg. Nos.:

2690773 - Baron

Wheels & Tires Group

REF NO	PART NO.	QTY.	DESCRIPTION
1	1735010SM	2	WHEEL & TIRE ASSEMBLY (Front)
2	1735706YP	2	TIRE, 16 x 6-1/2-8 (Front)
3	2153038SM	2	TUBE, Tire
5	2172353SM	4	VALVE STEM & CAP
6	2860202SM	2	WASHER, Flat 3/4 x 1-5/8 x 1/8
7	1722717ASM	2	WASHER, Flat
8	1960114SM	2	WASHER, 3/4
9	2827794SM	2	RING
10	1722676SM	4	CAP, Hub
11	1960701SM	4	WASHER, 1 x 2-1/4 x 1/8
12	1726089SM	2	SPACER
13	1721400SM	2	PLATE & HUB WELDMENT
14	1733486SM	2	WHEEL & TIRE ASSEMBLY (Rear)
15	1736515YP	2	TIRE, 22 x 11-10 (Rear)
16	2157638SM	2	TUBE, Tire
18	2177725SM	10	NUT, Hex 7/16-20 For Wheel Bolt
19	2105337SM	2	KEY, Hi-Pro 1/4 x 2
20	1722726ASM	2	WASHER, Flat
21	1919394SM	2	WASHER, Flat
22	2834712SM	2	RING

Not for
Reproduction

Footnotes

The above parts group applies to the following Mfg. Nos.:

2690773 - Baron

Decals Group - Brand & Model

NOTE: Unless noted otherwise,
use the standard hardware torque
specification chart.

B987920

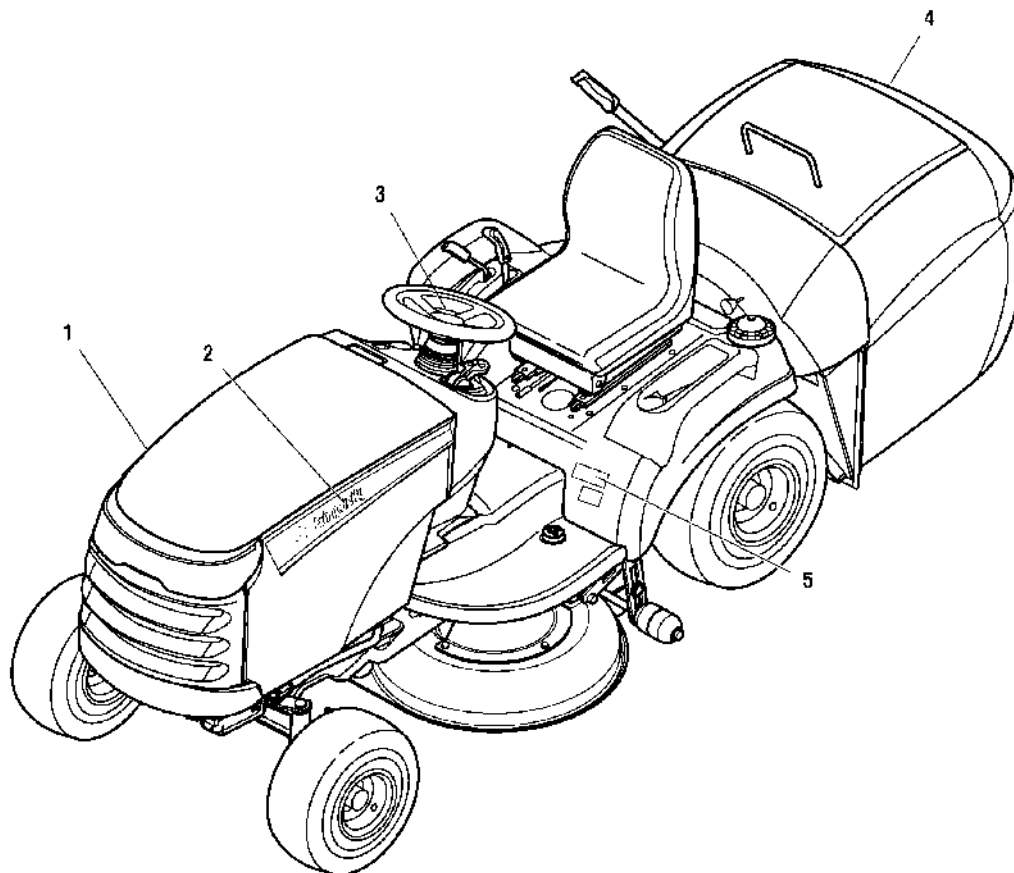

The above parts group applies to the following Mfg. Nos.:

2690773 - Baron

Decals Group - Brand & Model

REF NO	PART NO.	QTY.	DESCRIPTION
1	1727717SM	1	DECAL, Hood Stripe LH, Simplicity
2	1727718SM	1	DECAL, Hood Stripe RH, Simplicity
3	1731418SM	1	DECAL, ICON Simplicity
4	1723859SM	1	DECAL, Simplicity
5	1722784SM	1	DECAL, Baron

Not for
Reproduction

Footnotes

The above parts group applies to the following Mfg. Nos.:

2690773 - Baron

Decals Group - Safety & Common

NOTE: Unless noted otherwise,
use the standard hardware torque
specification chart.

C987920

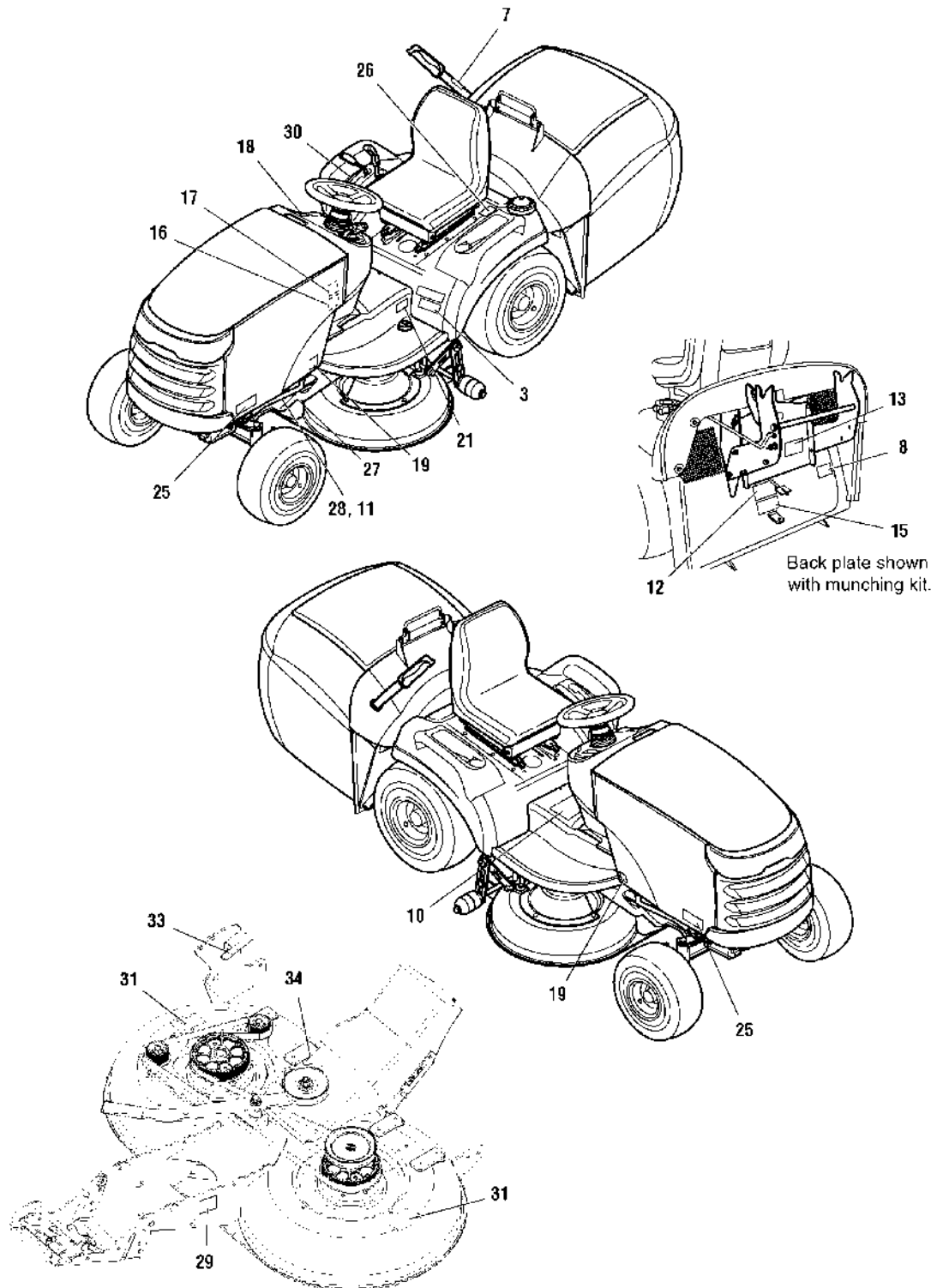

The above parts group applies to the following Mfg. Nos.:

2690773 - Baron

Decals Group - Safety & Common

REF NO	PART NO.	QTY.	DESCRIPTION
3	1730206SM	1	DECAL, 21HP
7	1723310SM	1	DECAL, Hopper
8	1720390SM	1	DECAL, Danger Catcher Open, Symbol
8	1730390SM	1	DECAL, Danger, thrown Objects
10	1734027SM	1	DECAL, Operator Tunnel Icons (CE/Export)
11	*	1	DECAL, Patent
12	1720391SM	1	DECAL, Danger Operating without Catcher
13	1735268SM	1	DECAL, Transmission Release Valve, Symbol
15	1721141SM	1	DECAL, Drawbar Max Load
16	1720454SM	1	DECAL, Touch Up Paint
17	1736193SM	1	DECAL, Belt and Blade
18	1722806SM	1	DECAL, Ignitiaon Switch Symbols
19	1723296SM	2	STICKER, Protective Clear, 1-3/4 x 1-3/4
21	1723317SM	1	DECAL, Hopper Pedal
25	1726373SM	1	DECAL, 4x 4
26	1724680SM	1	DECAL, Hopper Release
27	*	2	LABEL, Decibel
28	*	1	ID PLATE, Tractor
29	*	1	ID PLATE, Mower Deck
30	1723713SM	1	DECAL, Cruise/Lift
31	1720389SM	2	DECAL, Danger Rotating Blades, Symbols
33	1723470SM	1	DECAL, Height of Cut
34	1721107SM	1	DECAL, Danger Discharge Tube, Symbols (Right side of discharge chute)

Footnotes

Note* Not a serviceable part.

The above parts group applies to the following Mfg. Nos.:

2690773 - Baron

40" Mower Deck - Belt, Idle Arm & Hitch

987994

NOTE: Unless noted otherwise,
use the standard hardware torque
specification chart.

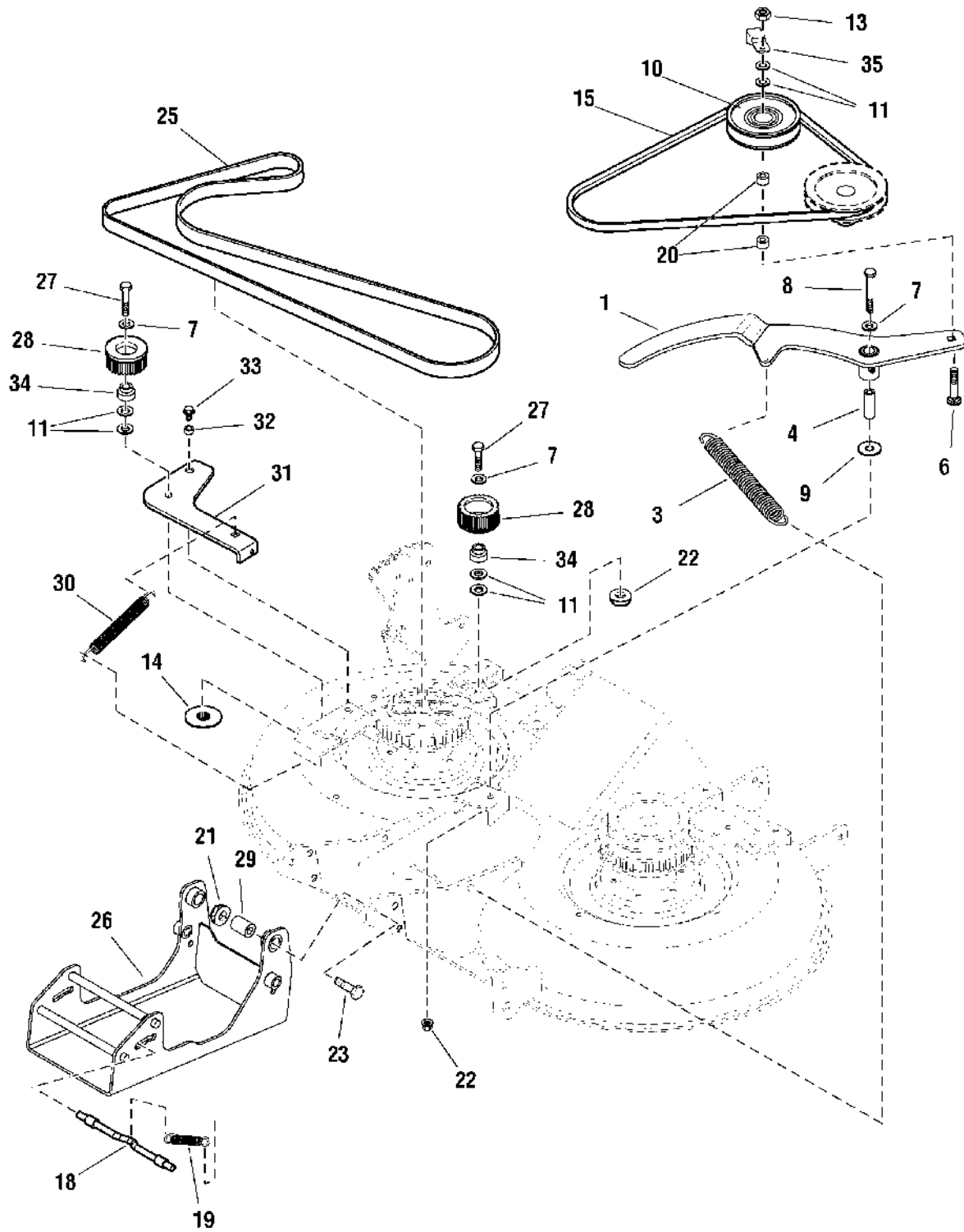

The above parts group applies to the following Mfg. Nos.:

2690773 - Baron

40" Mower Deck - Belt, Idle Arm & Hitch

REF NO	PART NO.	QTY.	DESCRIPTION
1	1720444SM	1	IDLER ARM ASSEMBLY, w/Bushings
3	1715435SM	1	SPRING, Extension
4	1657242SM	1	SPACER
6	1960615SM	1	CARRIAGE BOLT, 3/8-16 x 2-1/2
7	1922755SM	3	WASHER
8	1960614SM	1	CAPSCREW, Hex Head, 3/8-16 x 3, G8
9	1933263SM	1	WASHER
10	2101096SM	1	PULLEY, 4-1/2 OD
11	1924940SM	6	WASHER
13	1919439SM	1	NUT, Hex Lock ESNA, 3/8-16
14	1721425SM	1	WASHER & LOCK NUT ASSEMBLY, 3/8-16
15	1735714SM	1	V-BELT
17	1720044ASM	1	HITCH, Mower
18	1715759SM	1	ROD
19	2156302SM	1	SPRING, Extension
20	2157081SM	2	SPACER
22	1928352SM	2	NUT, Hex Flange Lock, 3/8-16
21	2860681SM	2	NUT, Spiral Flange Toplock, 3/8-16
23	1921968SM	2	CAPSCREW, Hex Head, 3/8-16 1-3/8
25	1724626SM	1	BELT, Timing
26	1732977ASM	1	HITCH
27	1923701SM	2	CAPSCREW, Hex Head, 3/8-16 x 2
28	1731892SM	2	PULLEY, Idler
29	1736018SM	1	SPACER
30	1674671SM	1	SPRING, Extension
31	1726387ASM	1	ARM, Idler
32	1666697SM	1	SPACER
33	1930601SM	1	CAPSCREW, Hex Head Taptite, 5/16-18 x 5/8
34	1719221SM	2	HUB, Pulley
35	1719842ASM	1	STOP, Belt

Footnotes

The above parts group applies to the following Mfg. Nos.:

2690773 - Baron

40" Mower Deck - Height Adjustment & Roller Bar

987993

NOTE: Unless noted otherwise,
use the standard hardware torque
specification chart.

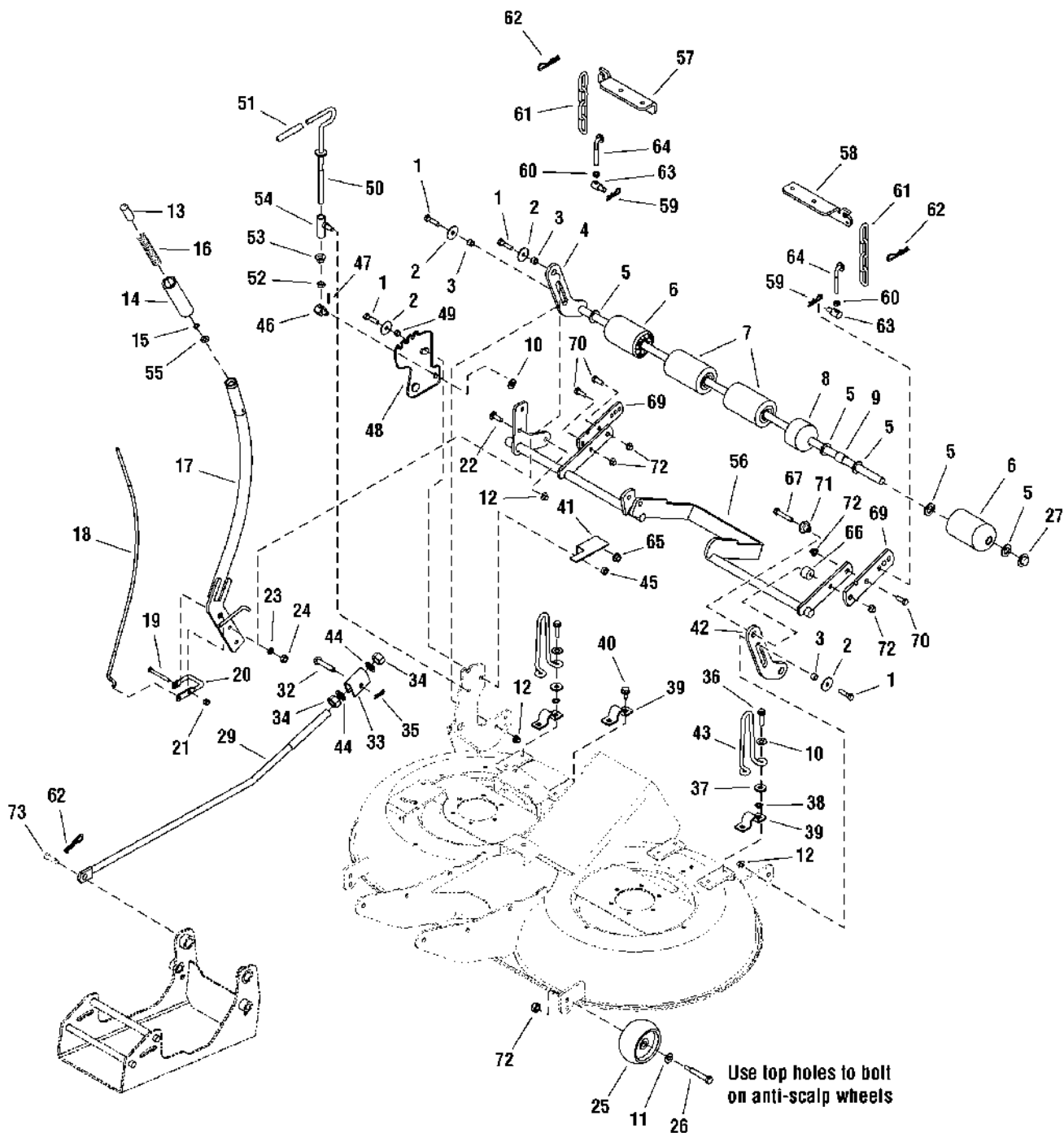

The above parts group applies to the following Mfg. Nos.:

2690773 - Baron

40" Mower Deck - Height Adjustment & Roller Bar

REF NO	PART NO.	QTY.	DESCRIPTION
1	1921977SM	4	CAPSCREW, Hex Head, 5/16-18 x 1-1/4 G5
2	1960044SM	3	WASHER, 5/16
3	1960236SM	3	SPACER
4	1733081ASM	1	SHAFT & BAR ASSEMBLY, Roller
5	1924366SM	5	WASHER, 5/8
6	1722036SM	2	ROLLER, Round-End, 4.1
7	1668513SM	6	ROLLER, Flat-End, 4.1
8	1717675SM	1	ROLLER, Round-End, 2.05
9	1602946SM	1	SPACER
10	1924940SM	8	WASHER, Flat, 3/8
11	1960170SM	2	WASHER, Flat, 1/2
12	2860643SM	3	NUT, Hex Flange 5/16-18 Colar Lock
13	1723124SM	1	BUTTON, Red Nylon for 1/4 Rod
14	1713995SM	1	GRIP, Soft
15	1960674SM	1	NUT, Push Pal 1/4 Diameter Thread
16	1723321SM	1	SPRING, Compression
17	1732751ASM	1	HANDLE ASSEMBLY, Lift Curved
18	1732754SM	1	ROD, Curved, Latch
19	1921159SM	1	CAPSCREW, Hex Head 1/4-20 x 2-1/4 G5
20	1720599SM	1	LATCH
21	1920397SM	1	NUT, Hex Lock ESNA Light 1/4-20
22	1931335SM	2	BOLT, Carriage, 5/16-18 x 1 G5
23	1917356SM	2	LOCKWASHER, Spring 5/16
24	1917372SM	2	NUT, Hex 5/16-18
25	1714760SM	2	WHEEL
26	2108765SM	2	Bolt, Shoulder, 3/8-16 x 2.87
27	1960520SM	1	NUT, Push for 5/8 Diameter Stud Capped
28	1922606SM	1	CAPSCREW, Hex Head 3/8-16 x 1-3/4 G8
29	1722661SM	1	ROD, Pitch Adjust
30	1706644SM	1	SPACER, 3/8 x 3/4 x 15/16
31	2860681SM	1	NUT, Hex Toplock Spiralock Flange 3/8-16
32	2118053SM	1	PIN, Round Head Drilled 3/8 x 2
33	1706645ASM	1	TRUNNION, Pitch Adjust
34	1915726SM	2	NUT, Hex 5/8-11
35	1722460SM	1	PIN, Quick, Retaining
36	1931202SM	4	SCREW, Hex Washer Head Taptite 5/16-18 x 1-1/4
37	1919381SM	4	WASHER, 3/8
38	1933988SM	4	NUT, Push Pal 5/16 Diameter Thread
39	1665374SM	3	STRAP, Rocker Shaft
40	1664847SM	2	SCREW, Hex Washer Head Taptite 5/16-18 x 3/4
41	1720931ASM	1	BRACKET, Height of Cut
42	1734987ASM	1	BAR, Roller
43	1719929SM	2	STOP, Up
44	1960703SM	2	WASHER, 5/8

Footnotes

The above parts group applies to the following Mfg. Nos.:

2690773 - Baron

40" Mower Deck - Height Adjustment & Roller Bar

987993

NOTE: Unless noted otherwise,
use the standard hardware torque
specification chart.

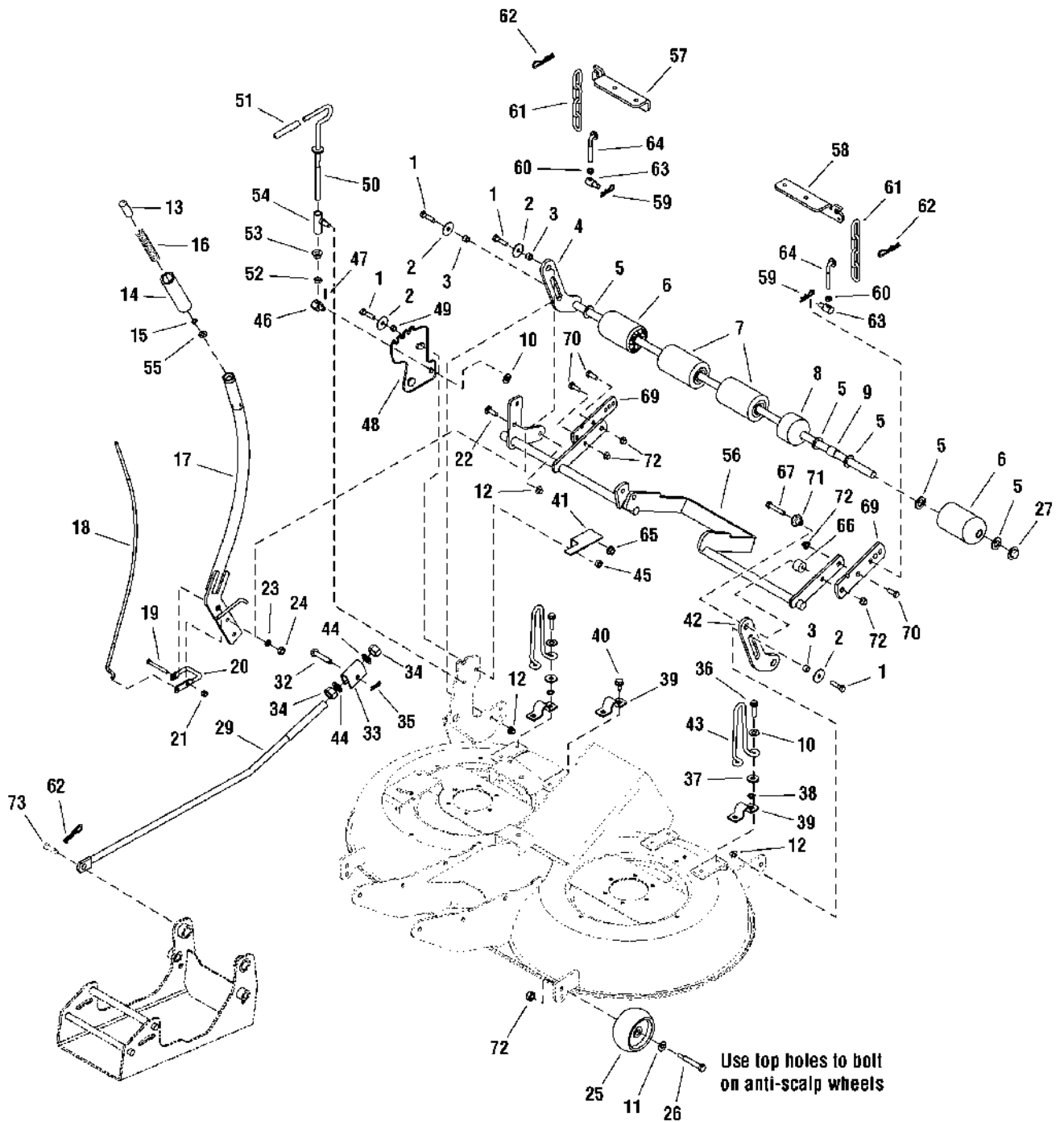

The above parts group applies to the following Mfg. Nos.:

2690773 - Baron

40" Mower Deck - Height Adjustment & Roller Bar

REF NO	PART NO.	QTY.	DESCRIPTION
45	1919438SM	1	NUT, Hex Lock Esna Light 5/16-18
46	2108512SM	1	PIVOT, 3/4 Hex
47	1918447SM	1	PIN, Cotter, .75
48	1723409ASM	1	BRACKET, Adjusting
49	1666697SM	1	SPACER
50	1720704SM	1	ROD & WASHER ASSEMBLY
51	1651820SM	1	GRIP, Black Vinyl
52	1917421SM	1	NUT, Hex Jam 3/8-16
53	1960601SM	1	NUT, Hex Flange 3/8-16
54	2108241SM	1	GUIDE ASSEMBLY, Rod
55	1918265SM	1	WASHER, 5/16
56	1735095ASM	1	SHAFT ASSEMBLY, Rocker
57	1727102ASM	1	HANGER, R.H.
58	1727103ASM	1	HANGER, L.H.
59	1960074SM	2	CLIP, Hair Pin
60	1920161SM	2	NUT, Hex Jam 5/16-18
61	1708088ASM	2	CHAIN, Link, 4 links
62	1960033SM	2	CLIP, Hair Pin
63	1731382SM	2	TRUNNION
64	1731384SM	2	ROD, Height Adjusting
65	1930645SM	1	NUT, Hex Flange 3/8-16 Two-Way Lock
66	1718762SM	1	SPACER, .70
67	1921972SM	1	CAPSCREW, Hex Head 5/16-18 x 2-1/2
69	1736359ASM	2	BAR, Extension
70	1923490SM	3	CAPSCREW, 3/8-16 x 1.0
71	1704082SM	1	NUT, Adjusting
72	1960687SM	6	NUT, Hex-Flange, 3/8-16, ESNA, BLK

Footnotes

The above parts group applies to the following Mfg. Nos.:

2690773 - Baron

40" Mower Deck - Housing, Arbors & Blade

987503

NOTE: Unless noted otherwise,
use the standard hardware torque
specification chart.

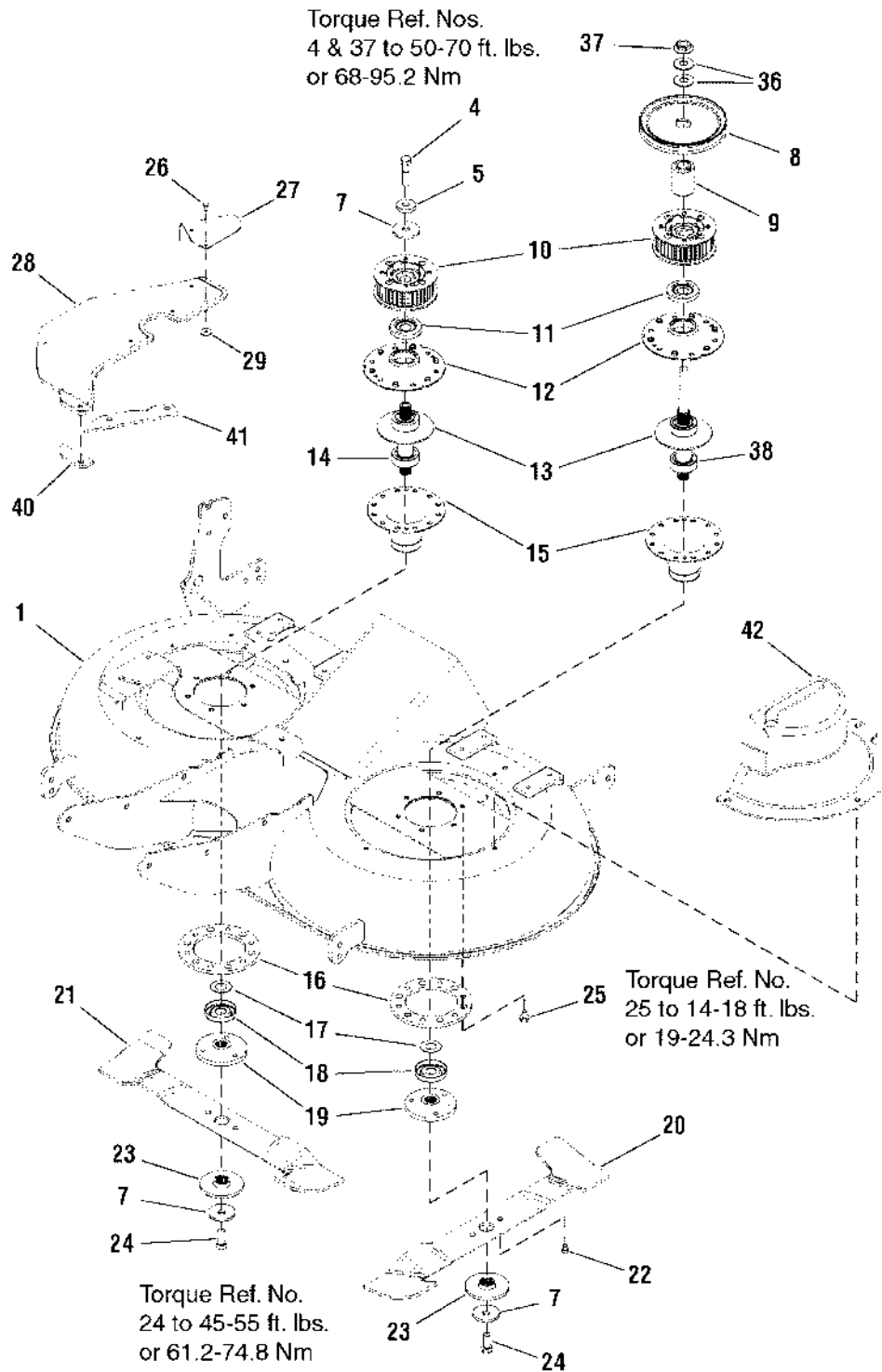

The above parts group applies to the following Mfg. Nos.:

2690773 - Baron

40" Mower Deck - Housing, Arbors & Blade

REF NO	PART NO.	QTY.	DESCRIPTION
1	1687321SM	1	HOUSING ASSEMBLY, 40" Orange
1	1687322SM	1	HOUSING ASSEMBLY, 40" Red
3	1664847SM	6	SCREW, Hex Washer Head Taptite 5/16-18 x 3/4
4	2830584SM	1	CAPSCREW, Hex Head 7/16-14 x 2-3/4 G8
5	1933263SM	1	WASHER, 7/16
7	1656916SM	3	WASHER, Spring
8	1732123SM	1	PULLEY
9	1719862SM	1	HUB
10	1732590SM	2	SPROCKET & FLANGE ASSEMBLY, Rivets/Screws 40"
11	1657969SM	2	SHIELD, Bearing, Mower Arbor Upoer Heat Treated
12	1655729ASM	2	HOUSING, Arbor Top
13	1707335SM	2	GASKET, Foam
14	1722396SM	1	ARBOR SHAFT & BEARINGS ASSEMBLY, 40"
15	1703273ASM	2	HOUSING & FITTING ASSEMBLY, Lower
16	1677274ASM	2	ADAPTER, Arbor
17	1700230SM	2	WASHER, Shim
18	1700229SM	2	SHIELD, Bearing
19	1655777SM	2	ADAPTER, Blade
20	1727477SM	1	BLADE, Mower L.H.
21	1727478SM	1	BLADE, Mower R.H.
22	1722258SM	2	PIN, Blade
23	1722257SM	2	WASHER, Spline
24	2827120SM	2	CAPSCREW, Hex Head 7/16-14 x 2-1/4 G8
25	1960373SM	12	SCREW, Hex Washer Head Taptite 5/16-18 x 1
26	1675044SM	2	RIVET, Pop
27	1721132ASM	1	GUARD, Extension
28	1724600SM	1	COVER, Arbor R.H.
29	1960096SM	2	WASHER
36	1713675SM	2	WASHER, Bellville
37	1714419SM	1	NUT, Hex Flange 9/16-18
38	1726826SM	1	ARBOR SHAFT & BEARINGS ASSEMBLY, 40"
40	1732960ASM	1	SHIM, Cover L.H.
41	1732961ASM	1	SHIM, Cover R.H.
42	1732301SM	1	COVER, Arbor L.H.

Footnotes

The above parts group applies to the following Mfg. Nos.:

2690773 - Baron

Not for
Reproduction

Not for
Reproduction

Not for
Reproduction

Hardware Identification & Torque Specifications

Torque Specification Chart								
FOR STANDARD METRIC MACHINE HARDWARE (Tolerance ± 20%)								
Property Class	5.6		8.8		10.9		12.9	
	Class 5.6		Class 8.8		Class 10.9		Class 12.9	
Size Of Hardware	in/lbs	Nm.	in/lbs	Nm.	in/lbs	Nm.	in/lbs	Nm.
	ft/lbs		ft/lbs		ft/lbs		ft/lbs	
M3	5.88	.56	13.44	1.28	19.2	1.80	22.92	2.15
M4	13.44	1.28	30.72	2.90	43.44	4.10	52.56	4.95
M5	26.4	2.50	60.96	5.75	5.97	8.10	7.15	9.7
M6	44.64	4.3	7.3	9.9	10.3	14	12.1	16.5
M7	5.2	7.1	12.1	16.5	16.9	23	19.9	27
M8	7.7	10.5	17.7	24	25	34	29	40
M10	15	21	35	48	50	67	59	81
M12	26	36	61	83	86.2	117	103	140
M14	42	58	101	132	136	185	162	220
M16	64	88	147	200	210	285	250	340
M18	89	121	202	275	287	390	346	470
M20	126	171	290	390	405	550	486	660
M22	169	230	390	530	559	745	656	890
M24	217	295	497	375	708	960	840	1140
M27	320	435	733	995	1032	1400	1239	1680
M30	435	590	995	1350	1401	1900	1681	2280
M33	590	800	1349	1830	1902	2580	2278	3090
M36	759	1030	1740	2360	2441	3310	2935	3980
M39	988	1340	2249	3050	3163	4290	3798	5150

Torque Specification Chart						
FOR STANDARD MACHINE HARDWARE (Tolerance ± 20%)						
Hardware Grade	No Marks		SAE Grade 5		SAE Grade 8	
	SAE Grade 2		SAE Grade 5		SAE Grade 8	
Size Of Hardware	in/lbs	Nm.	in/lbs	Nm.	in/lbs	Nm.
	ft/lbs		ft/lbs		ft/lbs	
8-32	19	2.1	30	3.4	41	4.6
8-36	20	2.3	31	3.5	43	4.9
10-24	27	3.1	43	4.9	60	6.8
10-32	31	3.5	49	5.5	68	7.7
1/4-20	66	7.6	8	10.9	12	16.3
1/4-28	76	8.6	10	13.6	14	19.0
5/16-18	11	15.0	17	23.1	25	34.0
5/16-24	12	16.3	19	25.8	29	34.0
3/8-16	20	27.2	30	40.8	45	61.2
3/8-24	23	31.3	35	47.6	50	68.0
7/16-14	30	40.8	50	68.0	70	95.2
7/16-20	35	47.6	55	74.8	80	108.8
1/2-13	50	68.0	75	102.0	110	149.6
1/2-20	55	74.8	90	122.4	120	163.2
9/16-12	65	88.4	110	149.6	150	204.0
9/16-18	75	102.0	120	163.2	170	231.2
5/8-11	90	122.4	150	204.0	220	299.2
5/8-18	100	136	180	244.8	240	326.4
3/4-10	160	217.6	260	353.6	386	525.0
3/4-16	180	244.8	300	408.0	420	571.2
7/8-9	140	190.4	400	544.0	600	816.0
7/8-14	155	210.8	440	598.4	660	897.6
1-8	220	299.2	580	788.8	900	1,244.0
1-12	240	326.4	640	870.4	1,000	1,360.0

The guides and ruler furnished below are designed to help you select the appropriate hardware.



Nut, M8

Thread Diameter (mm)
Inside Diameter (in)
Threads per inch

Nut, 1/2-16

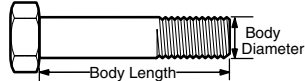

Screw, M8- 1.25 x 25

Thread Diameter (mm)
Body Diameter
Distance between threads (mm)
Threads per inch
Body Length (mm)
Body Length (in)

Screw, 1/2- 16 x 2

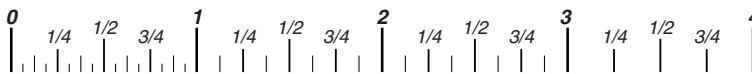

Standard Hardware Sizing

When a washer or nut is identified as **1/2"** (M8), this is the *Nominal size*, meaning the *inside diameter* is 1/2 inch (8mm metric thread diameter); if a second number is present it represents the *threads per inch* (distance between threads).

When bolt or capscrew is identified as **1/2 - 16 x 2"** (M8 - 1.25 x 50), this means the *Nominal size*, or body diameter is 1/2 inch (8mm metric thread diameter), the second number, 16, represents the *threads per inch*, (1.25 thread diameter). The final number is the body length of the bolt or screw, 2 inches (50mm).

NOTES

- These torque values are to be used for all hardware excluding: locknuts, self-tapping screws, thread forming screws, sheet metal screws and socket head setscrews.
- Recommended seating torque values for locknuts:
 - for prevailing torque locknuts - use 65% of grade 5 torques.
 - for flange whizlock nuts and screws - use 135% of grade 5 torques.
- Unless otherwise noted on assembly drawings, all torque values must meet this specification.

Common Hardware Types

Hex Head Capscrew



Washer

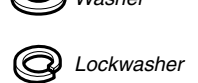

Carriage Bolt



Hex Nut

Wrench & Fastener Size Guide

1/4" Bolt or Nut Wrench—7/16"	5/16" Bolt or Nut Wrench—1/2"	3/8" Bolt or Nut Wrench—9/16"	7/16" Bolt or Nut Wrench (Bolt)—5/8" Wrench (Nut)—11/16"	1/2" Bolt or Nut Wrench—3/4"
M6 Bolt or Nut Wrench—10mm	M8 Bolt or Nut Wrench—13mm	M10 Bolt or Nut Wrench—17mm	M12 Bolt or Nut Wrench—19mm	M14 Bolt or Nut Wrench—22mm

Not for
Reproduction

**IT IS THE POLICY OF BRIGGS & STRATTON CORP. TO IMPROVE ITS PRODUCTS
WHENEVER IT IS POSSIBLE AND PRACTICAL TO DO SO. WE RESERVE THE RIGHT TO
MAKE CHANGES OR ADD IMPROVEMENTS AT ANY TIME WITHOUT INCURRING ANY
OBLIGATION TO MAKE SUCH CHANGES ON PRODUCTS.**

Briggs & Stratton Yard Power Products Group

3515 N. 124 Street / PO Box 702
Wauwatosa, WI 53222 USA

www.simplicitymfg.com

© Copyright 2010 by Briggs & Stratton Corporation
Milwaukee, WI, USA. All rights reserved