

Baron XL

Series Lawn Tractors & Mower Decks

18HP Product

Mfg. No.	Description
2690622	Baron XL, 18HP Hydro RMO and 40" Mower Deck (CE/Export)

20HP Product

Mfg. No.	Description
2690621	Baron XL, 20HP Hydro RMO and 40" Mower Deck (CE/Export)
2690625	2420 XL, 20HP Hydro RMO and 40" Mower Deck (CE/Export)

21HP Product

Mfg. No.	Description
2690762	Baron, 21HP Hydro and 40" Mower Deck (CE/Export)
2690772	2421, 21HP Hydro RMO and 40" Mower Deck (CE/Export)

Mower Decks

Mfg. No.	Description
1695200	40" Mower Deck (CE/Export)
1695201	40" Mower Deck (CE/Export)

Not for
Reproduction

PRODUCT COMPONENTS	PAGES
Frame & Front Axle Group	4
Steering Group	6
Engine Group - 18HP & 20HP Briggs & Stratton, VANGUARD Twin	8
Engine Group - 18HP Briggs & Stratton, INTEK Single	10
Engine Group - Electric Clutch - 21HP Briggs & Stratton, Vanguard	12
Transmission Group - Tuff Torq K46BF	14
Control Group - Cruise Control	18
Controls Group	20
Electrical Group	24
Hood, Grille & Dash Group	28
Seat Deck & Fuel Tank Group	30
Hopper Group	32
Wheels & Tires Group	36
Decals Group - Brand & Model	38
Decals Group - Safety & Common	40
40" Mower Deck - Belt, Idle Arm & Hitch	42
40" Mower Deck - Height Adjustment & Roller Bar	44
40" Mower Deck - Housing, Arbors & Blade	48
Torque Specification Chart	Inside Back Cover

Not for
Reproduction

Frame & Front Axle Group

986818

NOTE: Unless noted otherwise, use the standard hardware torque specification chart.

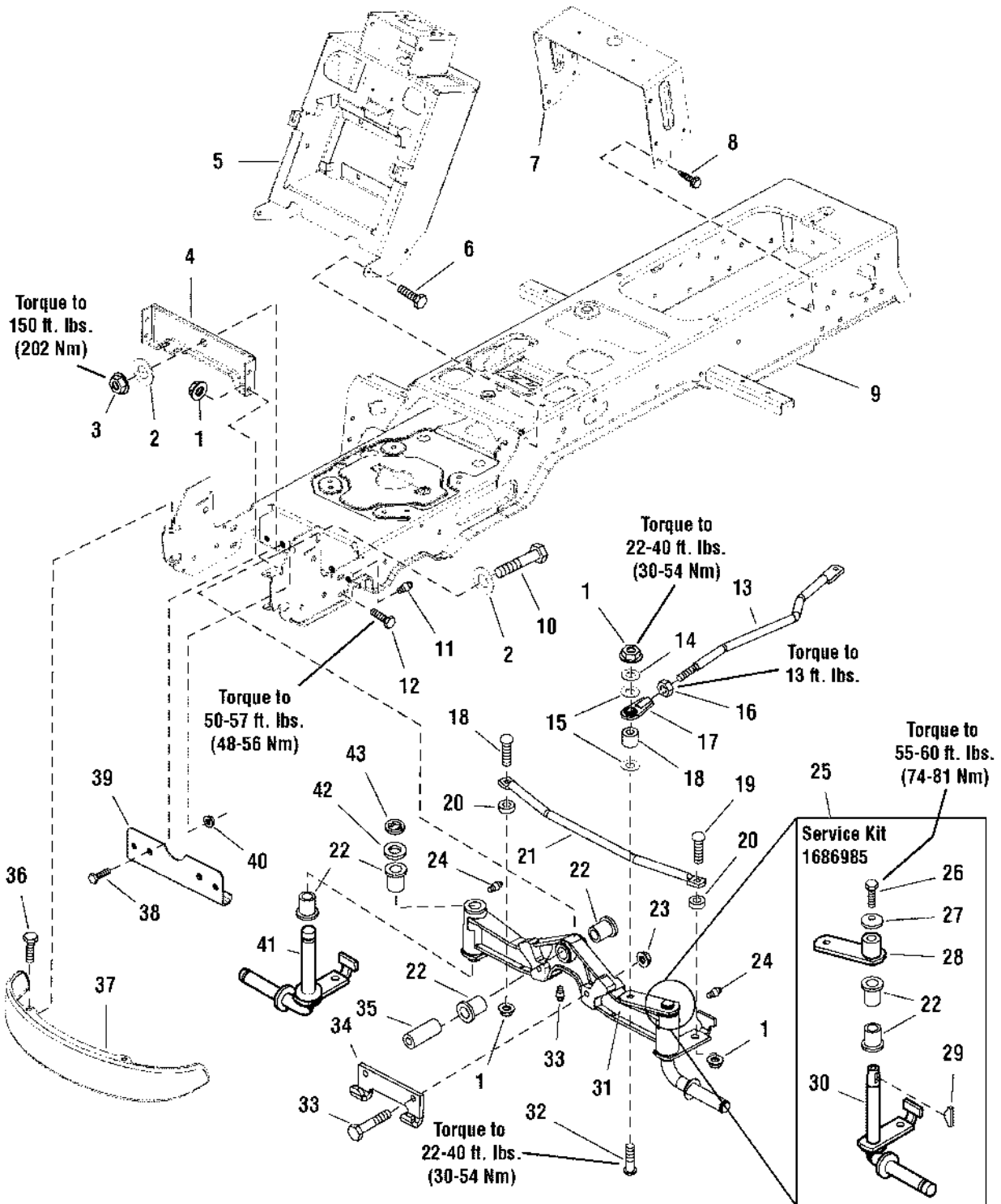

The above parts group applies to the following Mfg. Nos.:

- 2690621 - Baron XL
- 2690622 - Baron XL
- 2690625 - 2420 XL
- 2690762 - Baron
- 2690772 - 2421

Frame & Front Axle Group

REF NO	PART NO.	QTY.	DESCRIPTION
1	1930645SM	7	NUT, Hex Flange Lock, 3/8-16
2	1960035SM	2	WASHER
3	2860646SM	1	NUT, Hex Flange, 5/8-11
4	1722212ASM	1	PLATE, Axle
5	1724081ASM	1	TOWER & SUPPORT ASSEMBLY
6	1923683SM	4	CAPSCREW, Hex Head Taptite, 3/8-16 x 3/4
7	1723528ASM	1	SUPPORT
8	1664847SM	4	CAPSCREW, Hex Head Taptite, 5/16-18 x 3/4
9	1727396ASM	1	FRAME ASSEMBLY
10	2860645SM	1	CAPSCREW, 5/8-11 x 3-1/2
11	1704314SM	2	FITTING, Grease for Wear Plate, 1/4-20, with Ball
12	1933260SM	4	CAPSCREW, Hex Head, Flange Lock, 3/8-16 x 3/4
13	1722541SM	1	LINK, Drag
14	1922755SM	1	WASHER
15	1960103SM	2	WASHER
16	1919262SM	1	NUT, Hex Jam, 1/2-20
17	1702779SM	1	JOINT, Ball
18	1708236SM	1	SPACER
19	1931350SM	2	CARRIAGE BOLT, 3/8-16 x 1
20	1611705SM	2	SPACER
21	1722626ASM	1	ROD, Tie
22	1721682SM	6	BUSHING
23	1930650SM	2	NUT, Hex Flange Lock, 7/16-14
24	2821133SM	3	FITTING, Lube
25	1686985SM	1	SPINDLE REPLACEMENT KIT, LH (Includes Ref. Nos. 22, 26, 27, 28, 29 & 30)
26	2823485SM	1	CAPSCREW, 3/8-16 x 7/8, GR8
27	1663151SM	1	WASHER, Spring, 3/8
28	1725112SM	1	HUB & ARM ASSEMBLY
29	2830671SM	1	KEY, Woodruff
30	1724264SM	1	SPINDLE, LH
31	1722200ASM	1	AXLE ASSEMBLY, w/ LH Spindle, Complete (Includes Ref. Nos. 22, 24, 41, 42 & 43)
32	1931352SM	1	CARRIAGE BOLT, 3/8-16 x 1-1/2
33	1927531SM	2	CAPSCREW, Hex Head, 7/16-14 x 2, GR8
34	1721918ASM	1	HOOK, "J"
35	1721752SM	1	SPACER
36	1960086SM	4	SCREW, Torx Head, 5/16-18 x 7/8
37	1721805ASM	1	BUMPER, Black, Steel, Standard
37	1723502SM	1	BUMPER, Chrome, Optional
38	1930591SM	2	CAPSCREW, Hex Whiz Lock, 5/16-18 x 3/4
39	1724801ASM	1	PLATE, Axle Wear
40	1931277SM	2	NUT, Hex Falnge Whiz Lock, 5/16-18
41	1722199SM	1	SPINDLE, RH
42	1919394SM	1	WASHER
43	2832577SM	1	RETAINING RING

Footnotes

The above parts group applies to the following Mfg. Nos.:

2690621 - Baron XL
2690622 - Baron XL
2690625 - 2420 XL
2690762 - Baron
2690772 - 2421

Steering Group

986091

NOTE: Unless noted otherwise,
use the standard hardware torque
specification chart.

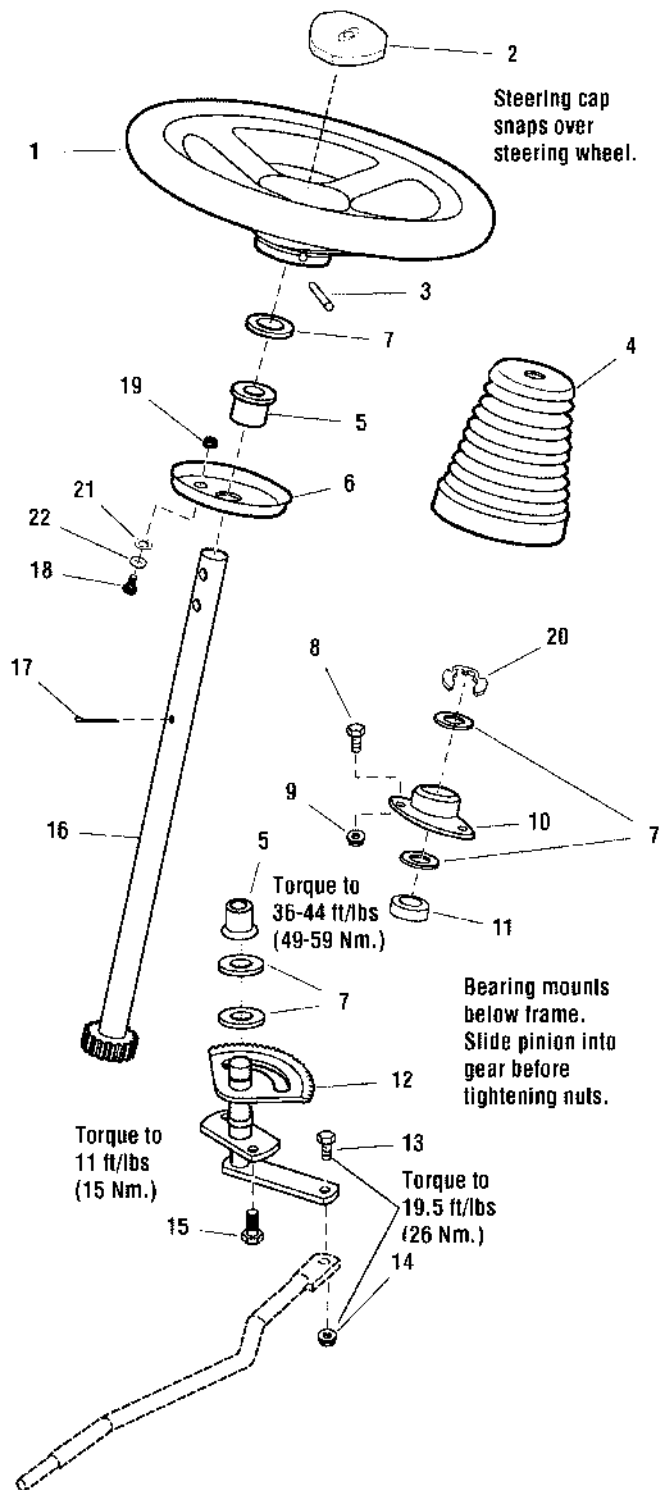

The above parts group applies to the following Mfg. Nos.:

2690621 - Baron XL
2690622 - Baron XL
2690625 - 2420 XL
2690762 - Baron
2690772 - 2421

Steering Group

REF NO	PART NO.	QTY.	DESCRIPTION
1	1722318SM	1	STEERING WHEEL, Straight Shaft
2	1722319SM	1	CAP, Steering Wheel, Simplicity (Decal Not Included)
2	1725024SM	1	CAP, Steering Wheel, Plain
3	1960540SM	1	PIN, Spring
4	1722749SM	1	COVER, Black Rubber
5	2176440SM	2	BUSHING
6	1721736ASM	1	PLATE, Mounting Steering
7	1960114SM	5	WASHER
8	1933260SM	2	CAPSCREW, Hex Head Flange Lock, 3/8-16 x 3/4
9	1931211SM	2	NUT, Hex Whiz Lock, 3/8-16
10	1722459SM	1	BEARING, Flange
11	1722461SM	1	SPACER
12	1724470ASM	1	GEAR & SHAFT ASSEMBLY
13	1960032SM	1	CAPSCREW, Hex Head, 3/8-16 x 1-1/4
14	1930645SM	1	NUT, Hex Flange Lock, 3/8-16
15	1664847SM	2	CAPSCREW, Hex Head Taptite, 5/16-18 x 3/4
16	1723604SM	1	SHAFT ASSEMBLY
17	1919314SM	1	PIN, Cotter
18	1931317SM	2	CARRIAGE BOLT, 1/4-20 x 3/4
19	2828372SM	2	NUT, Hex, 1/4-20
20	1611710SM	1	RING, Clipping Extension
21	1960114SM	2	WASHER
22	1933988SM	2	NUT, Push, 5/16

Not for
Reproduction

Footnotes

The above parts group applies to the following Mfg. Nos.:

2690621 - Baron XL
2690622 - Baron XL
2690625 - 2420 XL
2690762 - Baron
2690772 - 2421

Engine Group - 18HP & 20HP Briggs & Stratton, VANGUARD Twin

986833

NOTE: Unless noted otherwise, use the standard hardware torque specification chart.

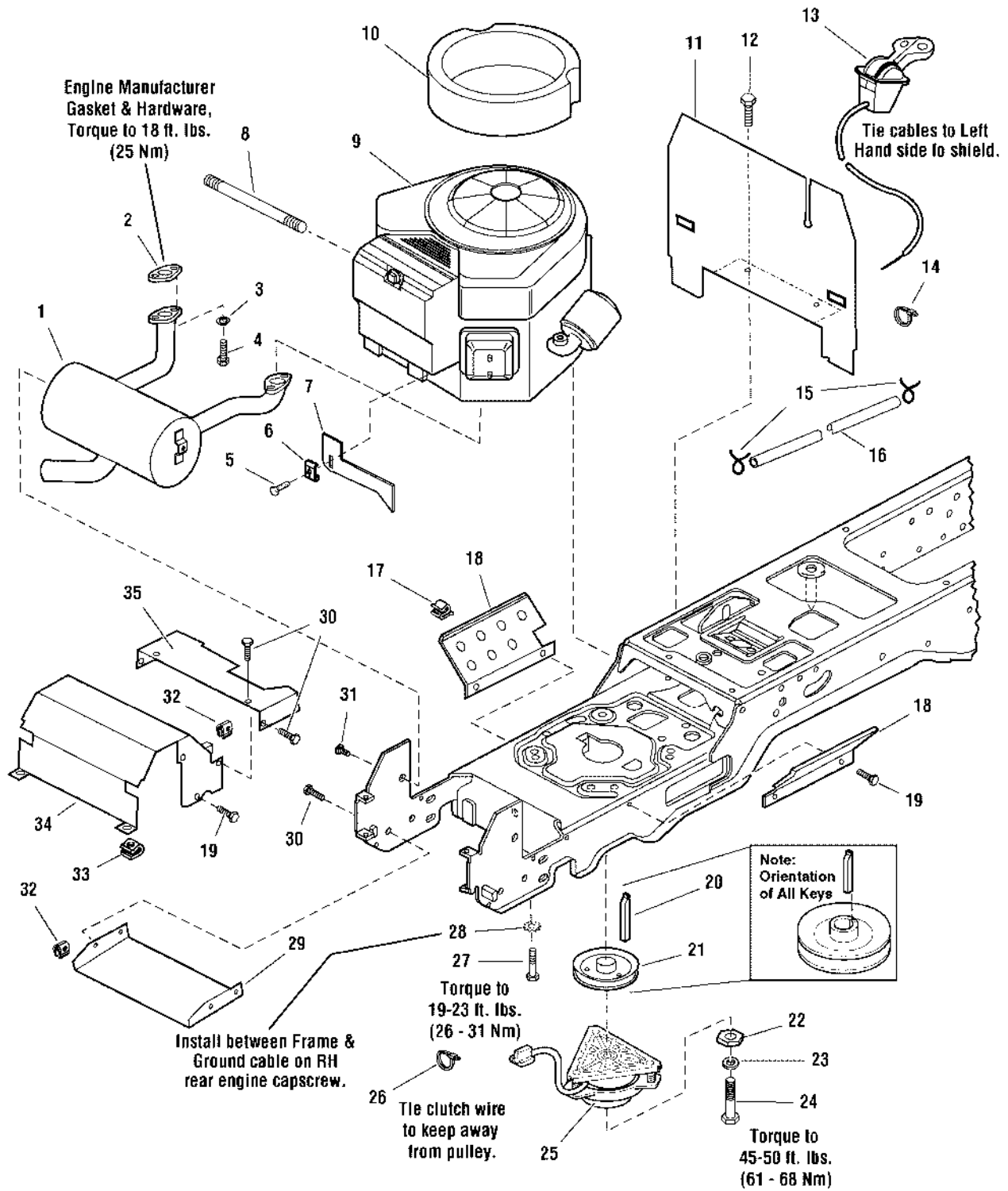

The above parts group applies to the following Mfg. Nos.:

- 2690621 - Baron XL
- 2690625 - 2420 XL

Engine Group - 18HP & 20HP Briggs & Stratton, VANGUARD Twin

REF NO	PART NO.	QTY.	DESCRIPTION
1	1722625SM	1	MUFFLER
2	*	1	GASKET
3	1917356SM	2	LOCKWASHER, 5/16
4	2860660SM	2	CAPSCREW, Socket Head, 5/16-18 x 7/8, G8
5	1728125SM	1	SCREW, Pan Head Trox, #10-32 x 5/8
6	1728126SM	1	CLAMP, Throttle Cable
7	1727696SM	1	PLATE, Limiter RPM
8	1723165SM	1	HOSE, Oil Drain
9	*	1	ENGINE, 18HP Briggs & Stratton INTEK Twin, Model 356777, Type 0113E1
9	*	1	ENGINE, 20HP Briggs & Stratton INTEK Twin, Model 358777, Type 0110E1
10	1722949SM	1	SEAL, Circle
11	1722388ASM	1	BULKHEAD
12	1925003SM	2	CAPSCREW, Hex Head Taptite, 1/4-20 x 1/2
13	1727223SM	1	CONTROL, Throttle Double 39" Long w/Knobs
14	1701011SM	1	TIE
15	2860112SM	2	CLAMP, Hose Type E
16	1723165SM	1	HOSE, 59" Long
17	2834683SM	2	CLIP, Wire
18	1722392ASM	2	SHIELD
19	1929000SM	8	SCREW, Hex Head Taptite, 1/4-20 x 3/8
20	1720463SM	1	KEY
21	1722288SM	1	PULLEY & HUB ASSEMBLY, 4-1/2 OD
22	1708264SM	1	WASHER, Hex
23	1918199SM	1	LOCKWASHER, 7/16
24	1960648SM	1	CAPSCREW, Hex Head, 7/16-20 x 2-3/4
25	1720532SM	1	CLUTCH, Electric, OGURA
26	2832747SM	1	TIE
27	2830598SM	4	CAPSCREW, Hex Head Taptite, 3/8-16 x 1-1/2
28	2820427SM	1	LOCKWASHER, External Tooth, 3/8
29	1722414ASM	1	SHIELD, Muffler Bottom
30	1960295SM	8	CAPSCREW, Hex Head Flange Lock, 1/4-20 x 5/8
31	1924856SM	2	CAPSCREW, Hex Head Taptite, 5/16-18 x 1/2
32	1960368SM	8	NUT, Speed, 1/4-20
33	1935255SM	2	NUT, Speed, 5/16-18
34	1722389ASM	1	DUCT, Muffler Top
35	1722390ASM	1	DUCT, Muffler Extension

Footnotes

Note* See your local Briggs & Stratton distributor for parts and service.

The above parts group applies to the following Mfg. Nos.:

2690621 - Baron XL
2690625 - 2420 XL

Engine Group - 18HP Briggs & Stratton, INTEK Single

986722

NOTE: Unless noted otherwise,
use the standard hardware torque
specification chart.

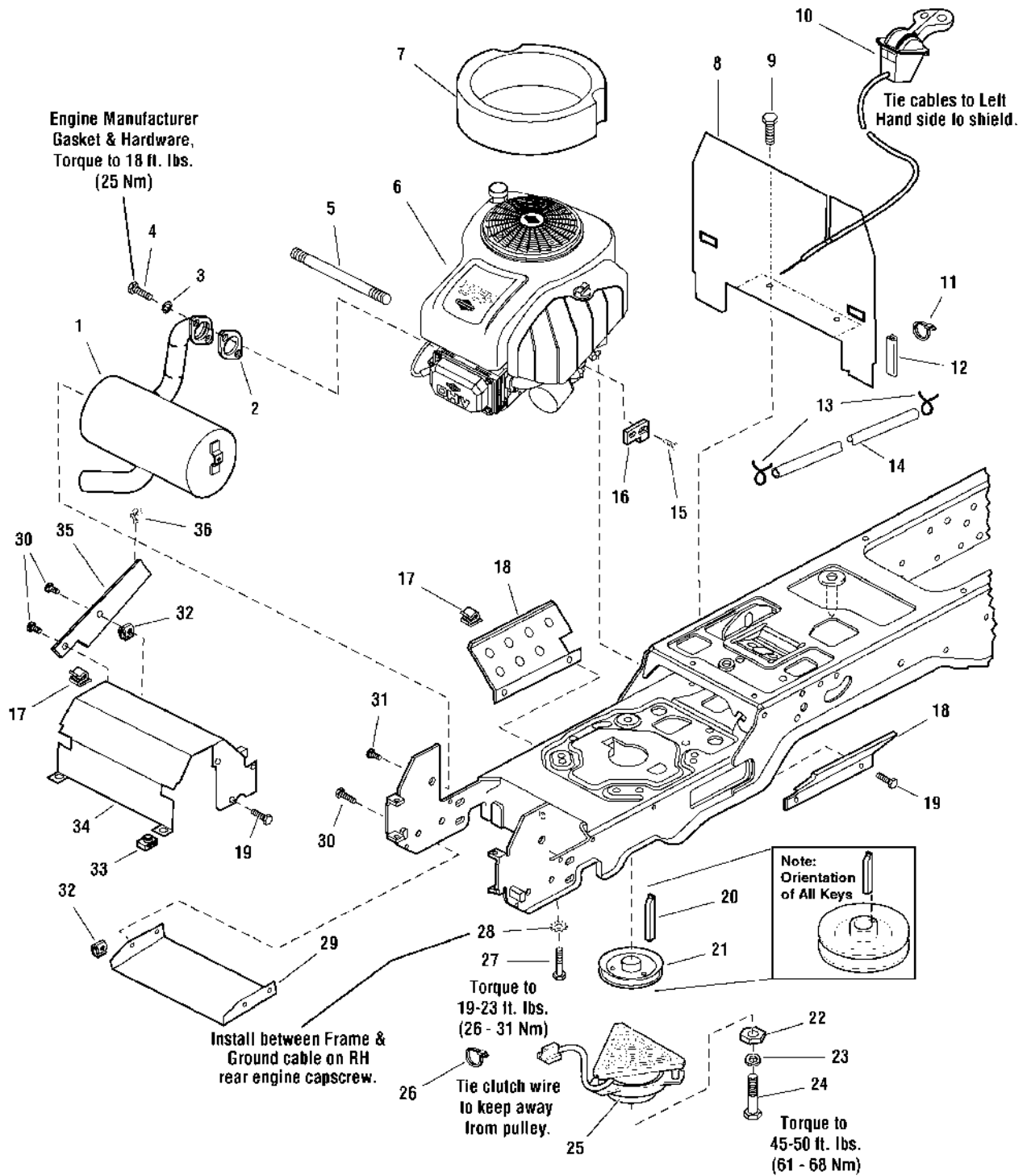

The above parts group applies to the following Mfg. Nos.:

2690622 - Baron XL

Engine Group - 18HP Briggs & Stratton, INTEK Single

REF NO	PART NO.	QTY.	DESCRIPTION
1	1723467SM	1	MUFFLER
2	*	2	GASKET
3	1917356SM	4	LOCKWASHER, 5/16
4	2860660SM	4	CAPSCREW, Socket Head, 5/16-18 x 7/8, G8
5	1723165SM	1	HOSE, Oil Drain
6	*	1	ENGINE, 18HP Briggs & Stratton INTEK Single, Model 31H777, Type 0118E1
7	1722950SM	1	SEAL, Circle
8	1722388ASM	1	BULKHEAD
9	1925003SM	2	CAPSCREW, Hex Head Taptite, 1/4-20 x 1/2
10	1724013SM	1	CONTROL, Throttle/Choke
11	1701011SM	1	TIE
12	1723894SM	1	EDGING, Rubber
13	2860112SM	2	CLAMP, Hose Type E
14	1718678SM	1	HOSE, 59" Long
15	1726466SM	1	SCREW, Trox Head Taptite, #8-32 x 1/2
16	1726465SM	1	PLATE, Limiter RPM
17	2834683SM	2	CLIP, Wire
18	1722392ASM	2	SHIELD
19	1929000SM	3	SCREW, Hex Head Taptite, 1/4-20 x 3/8
20	1720463SM	1	KEY
21	1722288SM	1	PULLEY & HUB ASSEMBLY, 4-1/2 OD
22	1708264SM	1	WASHER, Hex
23	1918199SM	1	LOCKWASHER, 7/16
24	1960648SM	1	CAPSCREW, Hex Head, 7/16-20 x 2-3/4
25	1720532SM	1	CLUTCH, Electric, OGURA
26	2832747SM	1	TIE
27	2830598SM	4	CAPSCREW, Hex Head Taptite, 3/8-16 x 1-1/2
28	2820427SM	1	LOCKWASHER, External Tooth, 3/8
29	1722414ASM	1	SHIELD, Muffler Bottom
30	1960295SM	6	CAPSCREW, Hex Head Flange Lock 1/4-20 x 5/8
31	1924856SM	2	CAPSCREW, Hex Head Taptite, 5/16-18 x 1/2
32	1960368SM	5	NUT, Speed, 1/4-20
33	1935255SM	2	NUT, Speed, 5/16-18
34	1722389ASM	1	DUCT, Muffler Top
35	1723897ASM	1	GUARD, Manifold Pipe
36	2172434SM	1	CLIP, Wire

Footnotes

Note* See your local Kohler distributor for parts and service.

The above parts group applies to the following Mfg. Nos.:

2690622 - Baron XL

Engine Group - Electric Clutch - 21HP Briggs & Stratton, Vanguard

NOTE: Unless noted otherwise, use the standard hardware torque specification chart.

2987912

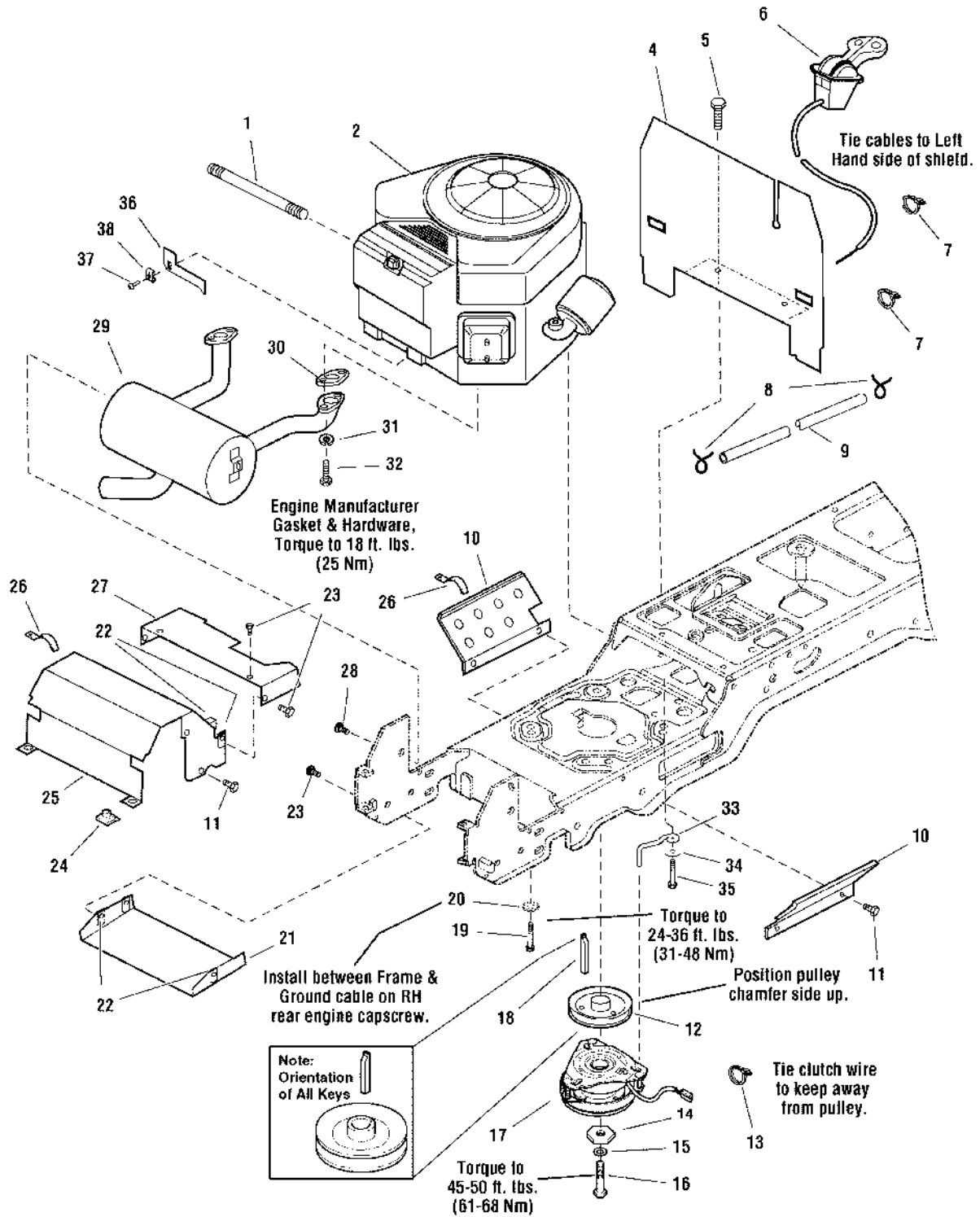

The above parts group applies to the following Mfg. Nos.:

- 2690762 - Baron
- 2690772 - 2421

Engine Group - Electric Clutch - 21HP Briggs & Stratton, Vanguard

REF NO	PART NO.	QTY.	DESCRIPTION
1	1723165SM	1	HOSE, Oil Drain, 10-1/2" Long, 3/8-18 Fittings
2	385777-0119-G1	1	*ENGINE, 21HP Briggs & Stratton Vanguard Twin (Engine Model 385777-0119-G1)
4	1722388ASM	1	BULKHEAD
5	1925003SM	2	CAPSCREW, Hex Washer Head Taptite, 1/2-20 x 1/2, Black
6	1734506SM	1	CONTROL, Throttle Double 39" Long w/Knobs
7	2825094SM	2	TIE, Wire, 7-5/16" Long
8	791850	2	CLAMP, Hose Type E
9	1734984SM	1	HOSE, Fuel, 59" Long
10	1722392ASM	2	SHIELD, Side
11	1927428SM	8	CAPSCREW, Hex Washer Head Taptite, 1/4-20 x 3/8
12	1722288SM	1	PULLEY & HUB ASSEMBLY
13	2832747SM	1	TIE, Self Locking, 3-5/8 Long
14	1708264SM	1	WASHER, Hex, 7/16, Black
15	1918199SM	1	LOCKWASHER, 7/16
16	1960648SM	1	CAPSCREW, Hex Head, 7/16-20 x 3-3/4
17	1686880SM	1	CLUTCH, Electric
18	1720463SM	1	KEY, HI PRO, 1/4 x 2 1/2
19	2830598SM	4	CAPSCREW, Hex Washer Head Taptite, 3/8-16 x 1-1/2
20	2820427SM	1	LOCKWASHER, External Tooth, 3/8
21	1722414ASM	1	SHIELD, Muffler Bottom
22	1960368SM	8	NUT, Speed, 1/4-20, Lug
23	1960295SM	4	CAPSCREW, Hex Flange Whiz Lock, 1/4-20 x 5/8
24	1935255SM	2	NUT, Speed, 5/16-18, Lug, Black
25	1722389ASM	1	DUCT, Muffler Top
26	2834683SM	2	CLIP, Wire 1/8
27	1722390ASM	1	DUCT, Muffler Extension
28	1924856SM	2	CAPSCREW, Hex Washer Head Taptite, 5/16-18 x 1/2, Black
29	1726920SM	1	MUFFLER, Briggs & Stratton, Vanguard Twin
30	*	1	GASKET, Briggs & Stratton, Vanguard Twin
31	*	4	LOCKWASHER, 5/16
32	*	4	CAPSCREW, Hex Flange Whiz Lock, 5/16-18 x 7/8
33	1732026SM	1	RETAINER, Clutch
34	1924940SM	1	WASHER, Flat 3/8
35	2827187SM	1	CAPSCREW, 3/8-16 x 1
36	1732396SM	1	PLATE, RMP Limiter
37	1728125SM	1	SCREW, Pan Head Torx
38	1728126SM	1	THROTTLE CABLE - Clamp

Footnotes

Note* See your local Briggs & Stratton distributor for parts and service.

The above parts group applies to the following Mfg. Nos.:

2690762 - Baron
2690772 - 2421

Transmission Group - Tuff Torq K46BF

986828

NOTE: Unless noted otherwise,
use the standard hardware torque
specification chart.

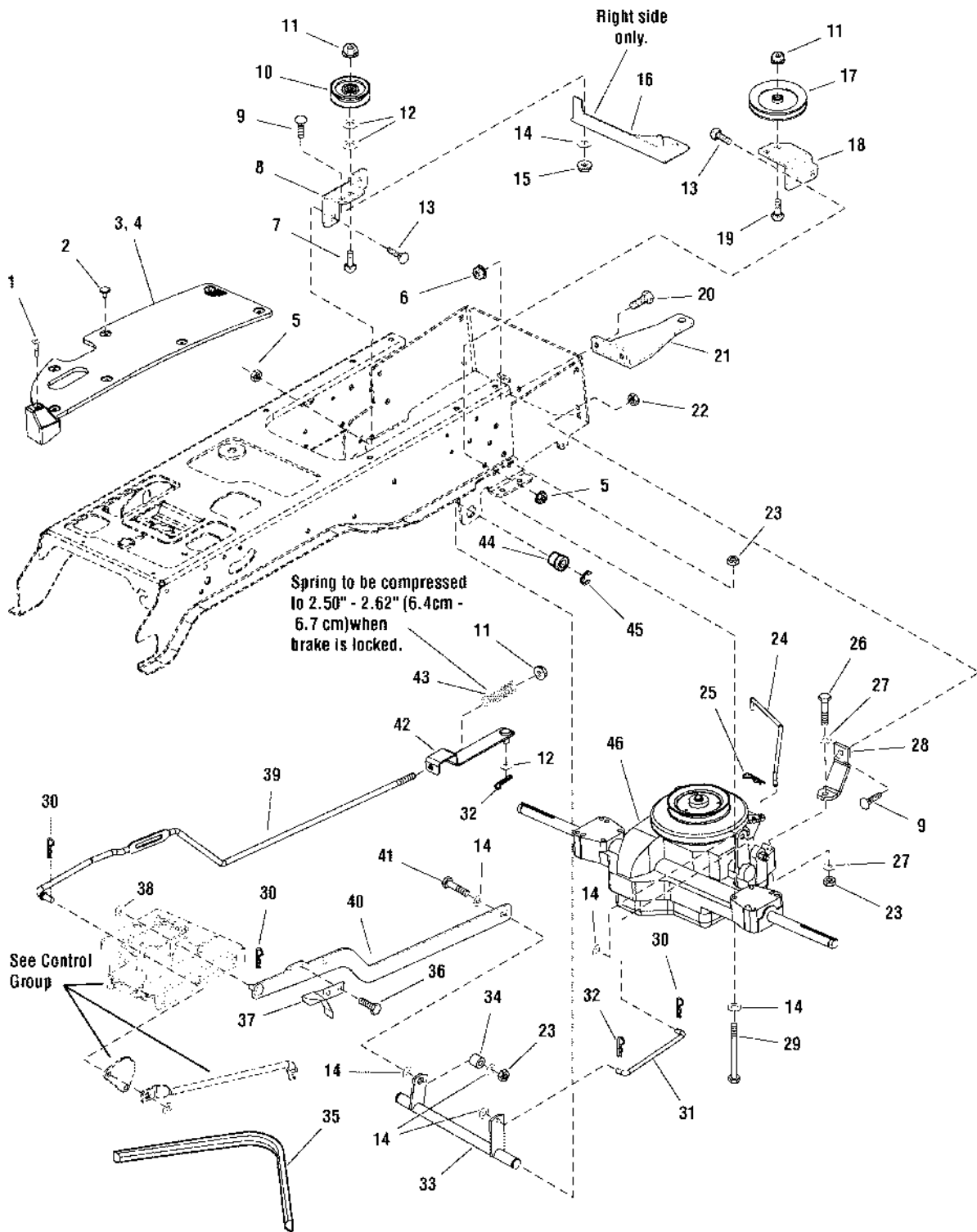

The above parts group applies to the following Mfg. Nos.:

- 2690621 - Baron XL
- 2690622 - Baron XL
- 2690625 - 2420 XL
- 2690762 - Baron
- 2690772 - 2421

Transmission Group - Tuff Torq K46BF

REF NO	PART NO.	QTY.	DESCRIPTION
1	1960676SM	2	SCREW, Pan Head Torx Taptite, 1/4-20 x 1-1/4
2	1704351SM	15	FASTENER, Panel 3/4 Head
3	1722173SM	1	PAD, Footrest, RH Black Vinyl Textured
4	1722174SM	1	PAD, Footrest with Differential Lock, LH Black Vinyl Textures
5	1960637SM	4	NUT, Hex KEPS, 3/8-16
6	1928352SM	2	NUT, Hex Flange, 3/8-16 Whiz Lock Large
7	1931353SM	1	CARRIAGE BOLT, 3/8-16 x 1-3/4 G5
8	1726052ASM	1	SUPPORT, Idler, RH
9	1931333SM	3	CARRIAGE BOLT, 5/16-18 x 3/4 G5
10	2174561SM	1	PULLEY, 3 in.
11	1960687SM	3	NUT, Hex Flange 3/8-16 ESNA
12	1922755SM	3	WASHER, 3/4
13	1931350SM	4	CARRIAGE BOLT, 3/8-16 x 1 G5
14	1919326SM	10	WASHER, 5/16
15	1960684SM	2	NUT, Hex KEPS, 5/16-18 Conical Washer
16	1727431ASM	1	BRACKET, Chute Locator
17	1710545SM	1	PULLEY, Idler, 4 in.
18	1726053ASM	1	SUPPORT, Idler, LH
19	1931352SM	1	CARRIAGE BOLT, 3/8-16 x 1-1/2 G5
20	1921210SM	2	CAPSCREW, Hex Head, 3/8-16X1.000 G5 BLK
21	1727400ASM	1	DRAWBAR, 1/4 in. Thick
22	1960636SM	1	NUT, Hex KEPS, 5/16-18
23	1919438SM	6	NUT, Hex Lock ESNA Light, 5/16-18NC-3B
24	1727526SM	1	ROD, Transmission Release
25	1960221SM	1	CLIP, Hair Pin Spring
26	1921978SM	1	CAPSCREW, Hex Head 5/16-18 x 2 G5
27	1960141SM	2	WASHER, 5/16
28	1726055ASM	1	STRAP, Torque, 1/4 Thick 4 in. Long
29	1923141SM	4	CAPSCREW, Hex Head, 5/16-18 x 2-3/4 G5
30	1722460SM	3	PIN, Quick
31	1723045SM	1	ROD, Control
32	1918447SM	2	PIN, Cotter
33	1727552SM	1	SHAFT & ARMS ASSEMBLY, Control
34	1666697SM	1	SPACER, Powered Metal
35	1727407SM	1	V-BELT, Drive Belt
36	1924856SM	2	CAPSCREW, Hex Washer Head Taptite, 5/16-18 x 1/2
37	1727215ASM	1	ACTUATOR, Switch
38	1924940SM	1	WASHER, 3/8
39	1726057SM	1	ROD, Brake
40	1727473SM	1	ARM & PIN ASSEMBLY, Speed Control
41	1921333SM	1	CAPSCREW, Hex Head, 5/16-18 x 1 G5
42	1723267SM	1	BRACKET & PIN ASSEMBLY, Brake
43	1729277SM	1	SPRING, Compression
44	2176440SM	2	BUSHING, Nylon

Footnotes

The above parts group applies to the following Mfg. Nos.:

2690621 - Baron XL
2690622 - Baron XL
2690625 - 2420 XL
2690762 - Baron
2690772 - 2421

Transmission Group - Tuff Torq K46BF

986828

NOTE: Unless noted otherwise,
use the standard hardware torque
specification chart.

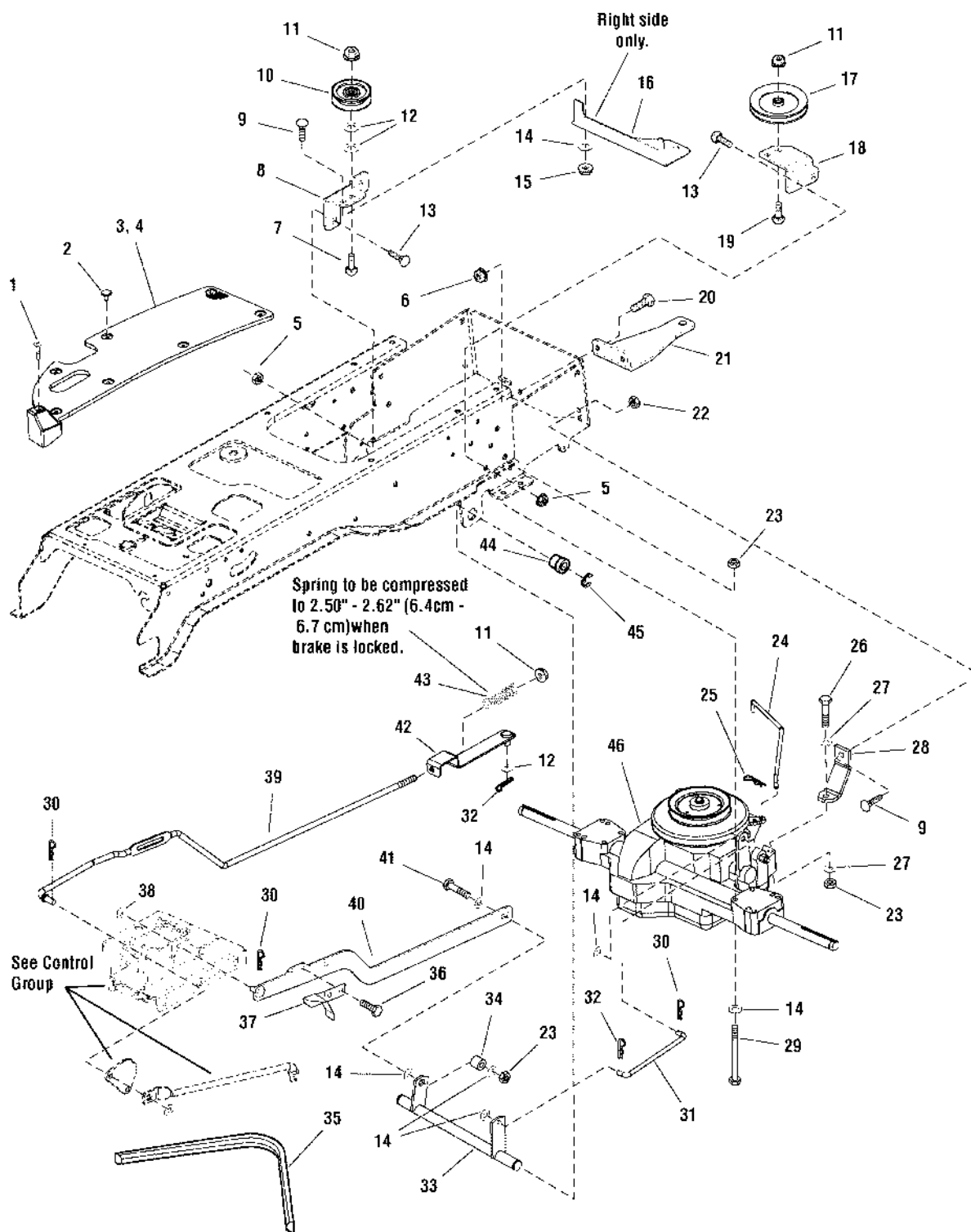

The above parts group applies to the following Mfg. Nos.:

- 2690621 - Baron XL
- 2690622 - Baron XL
- 2690625 - 2420 XL
- 2690762 - Baron
- 2690772 - 2421

Transmission Group - Tuff Torq K46BF

REF NO	PART NO.	QTY.	DESCRIPTION
45	2827794SM	2	RING, E Retaining
46	1727712SM	1	TRANSMISSION ASSEMBLY, Tuff Torq K46BF

Not for
Reproduction

Footnotes

The above parts group applies to the following Mfg. Nos.:

2690621 - Baron XL
2690622 - Baron XL
2690625 - 2420 XL
2690762 - Baron
2690772 - 2421

Control Group - Cruise Control

986814

NOTE: Unless noted otherwise,
use the standard hardware torque
specification chart.

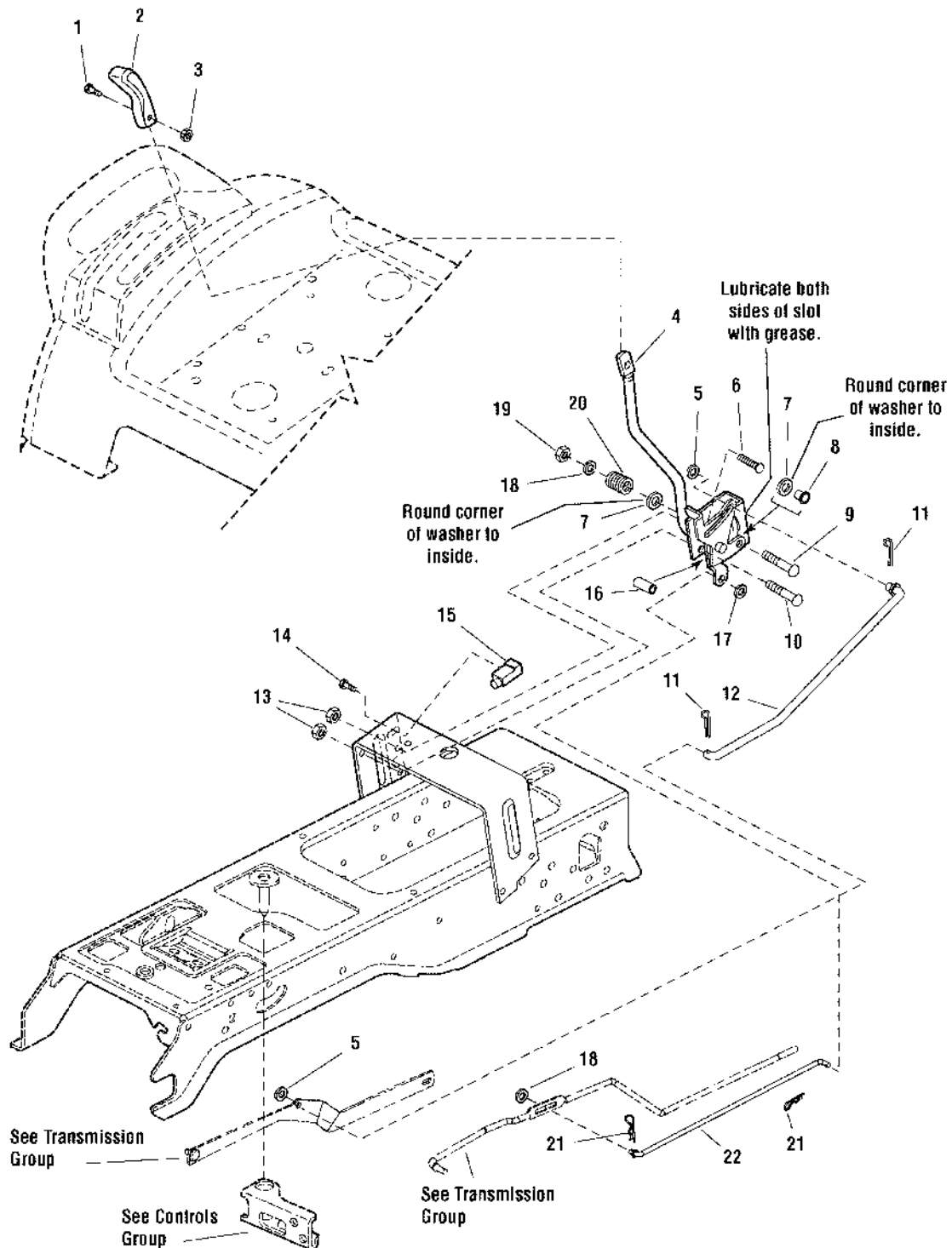

The above parts group applies to the following Mfg. Nos.:

2690621 - Baron XL
2690622 - Baron XL
2690625 - 2420 XL
2690762 - Baron
2690772 - 2421

Control Group - Cruise Control

REF NO	PART NO.	QTY.	DESCRIPTION
1	1960666SM	1	CAPSCREW, Torx Socket Head, 1/4-20 x 7/8
2	1722303SM	1	KNOB, Cruise
3	1920397SM	1	NUT, Hex ESNA Lock, 1/4-20
4	1723258SM	1	LEVER & BRACKET ASSEMBLY, Cruise
5	1960103SM	3	WASHER
6	1931333SM	1	CARRIAGE BOLT, 5/16-18 x 3/4
7	1926192SM	2	WASHER, 9/16 x 1-1/4 x 1/8
8	1709043SM	1	SPACER
9	1931342SM	1	CARRIAGE BOLT, 5/16-18 x 2-3/4
10	1960273SM	1	CARRIAGE BOLT, 5/16-18 x 2-1/4
11	1918447SM	2	PIN, Cotter
12	1726059SM	1	ROD, Cruise
13	1960636SM	2	NUT, Hex KEPS, 5/16-18
14	1960001SM	2	CAPSCREW, Hex Head Plastite, 10-14 x 5/8
15	1717050SM	1	SWITCH, Push, Neutral Start, Gray
16	1722080SM	1	SPACER
17	1919326SM	1	WASHER
18	1919381SM	2	WASHER
19	1919438SM	1	NUT, Hex ESNA Lock, 5/16-18
20	1677746SM	1	SPRING, Compression
21	1722460SM	2	PIN, Quick
22	1723099SM	1	ROD, Cruise Return

Not for
Reproduction

Footnotes

The above parts group applies to the following Mfg. Nos.:

2690621 - Baron XL
2690622 - Baron XL
2690625 - 2420 XL
2690762 - Baron
2690772 - 2421

Controls Group

987595

NOTE: Unless noted otherwise,
use the standard hardware torque
specification chart.

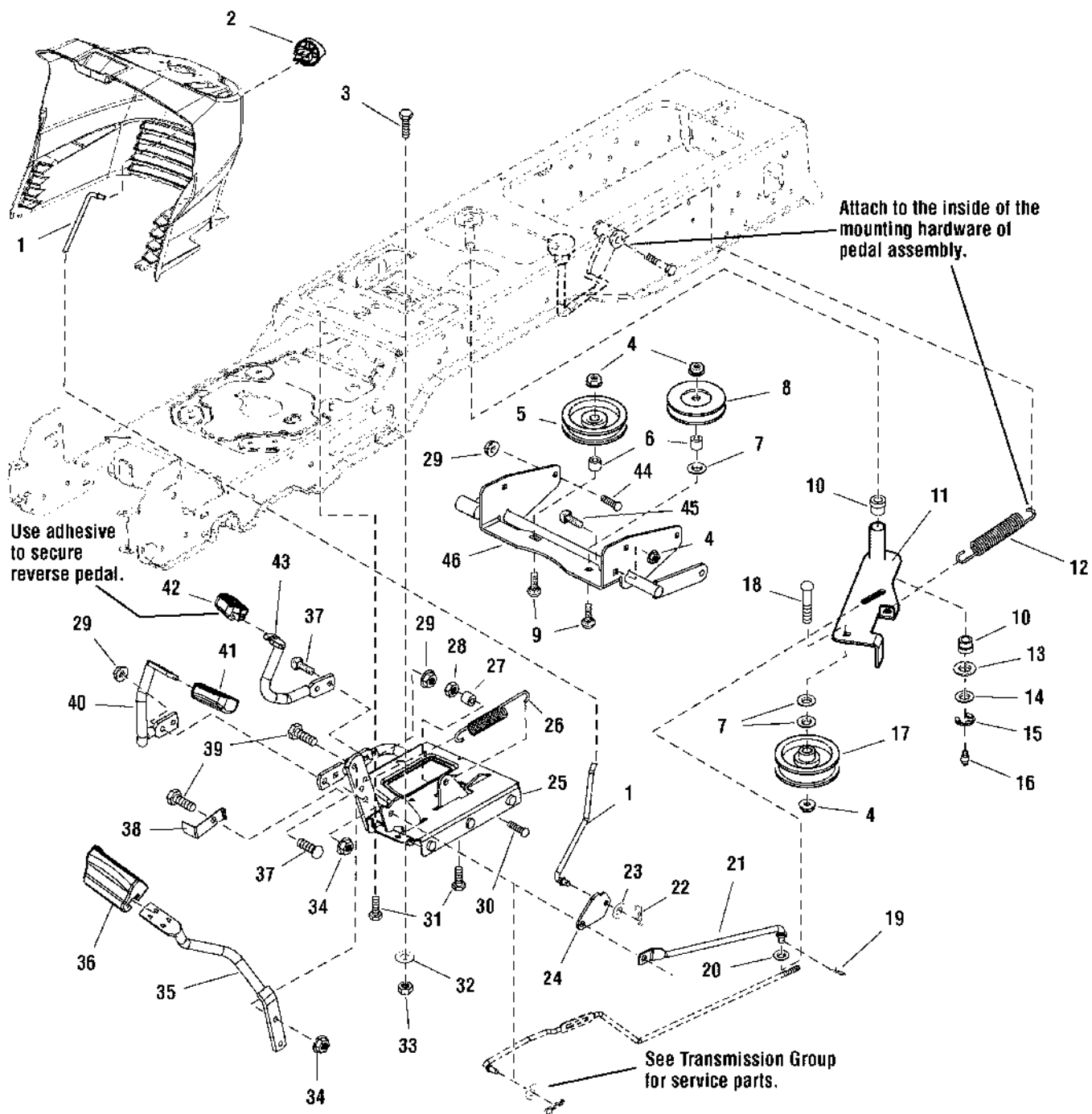

The above parts group applies to the following Mfg. Nos.:

- 2690621 - Baron XL
- 2690622 - Baron XL
- 2690625 - 2420 XL
- 2690762 - Baron
- 2690772 - 2421

Controls Group

REF NO	PART NO.	QTY.	DESCRIPTION
1	1721353SM	1	ROD, Brake
2	1721891SM	1	KNOB, Push On, Red
3	1930591SM	1	CAPSCREW, Hex Head Flange Lock, 5/16-18 x 3/4
4	1960687SM	3	NUT, Hex Flange, 3/8-16 ESNA
5	1721134SM	1	PULLEY ASSEMBLY, 3 OD, W/Bearing
6	1667811SM	2	SPACER
7	1922755SM	3	WASHER, 3/8
8	1710545SM	1	PULLEY, Idler 4 OD
9	1960315SM	2	CARRIAGE BOLT, 3/8-16 x 2 G5
10	1663114SM	2	BUSHING
11	1727370SM	1	ARM & HUB ASSEMBLY, Idler
12	1733844SM	1	SPRING, Extension
13	1960020SM	1	WASHER, 5/8
14	1924366SM	1	WASHER, 5/8
15	1704420SM	1	RING, Clipping
16	1704314SM	1	FITTING, Lube, 1/4 Ball Check
17	1710539SM	1	PULLEY, Idler 3-1/4 OD
18	1960315SM	1	CARRIAGE BOLT, 3/8-16 x 2 G5
19	1918447SM	1	PIN, Cotter
20	1924940SM	1	WASHER
21	1727408SM	1	ROD, Brake (Flat Ends)
22	1722460SM	1	PIN, Quick
23	1919326SM	1	WASHER
24	1721354ASM	1	LATCH, Brake
25	1726763SM	1	CONTROL ASSEMBLY, Foot Pedal
26	1721995SM	1	SPRING, Extension
27	1686612SM	1	CAM, Roller
28	1920397SM	1	NUT, Hex Lock ESNA, 1/4-20
29	1960636SM	8	NUT, Hex KEPS, 5/16-18
30	1931320SM	1	CARRIAGE BOLT, 1/4-20 x 1-1/4
31	1664847SM	3	CAPSCREW, Hex head Washer Taptite, 5/16-18 x 3/4
32	1919381SM	1	WASHER
33	1919438SM	1	NUT, Hex Lock ESNA, 5/16-18
34	1927557SM	3	NUT, Hex Flange Lock, 5/16-18
35	1722535ASM	1	PEDAL, Brake
36	1721577SM	1	PAD, Brake Pedal
37	1931334SM	4	CARRIAGE BOLT, 5/16-18 x 7/8
38	1722083ASM	1	ACTUATOR, Switch
39	1921333SM	3	CAPSCREW, Hex Head, 5/16-18 x 1
40	1722070ASM	1	PEDAL, Forward
41	1721675SM	1	PAD, Foot Pedal Forward
42	1721674SM	1	PAD, Foot Pedal Reverse
43	1722071ASM	1	PEDAL, Reverse
44	1931333SM	4	CARRIAGE BOLT, 5/16-18 x 3/4

Footnotes

The above parts group applies to the following Mfg. Nos.:

2690621 - Baron XL
2690622 - Baron XL
2690625 - 2420 XL
2690762 - Baron
2690772 - 2421

Controls Group

987595

NOTE: Unless noted otherwise,
use the standard hardware torque
specification chart.

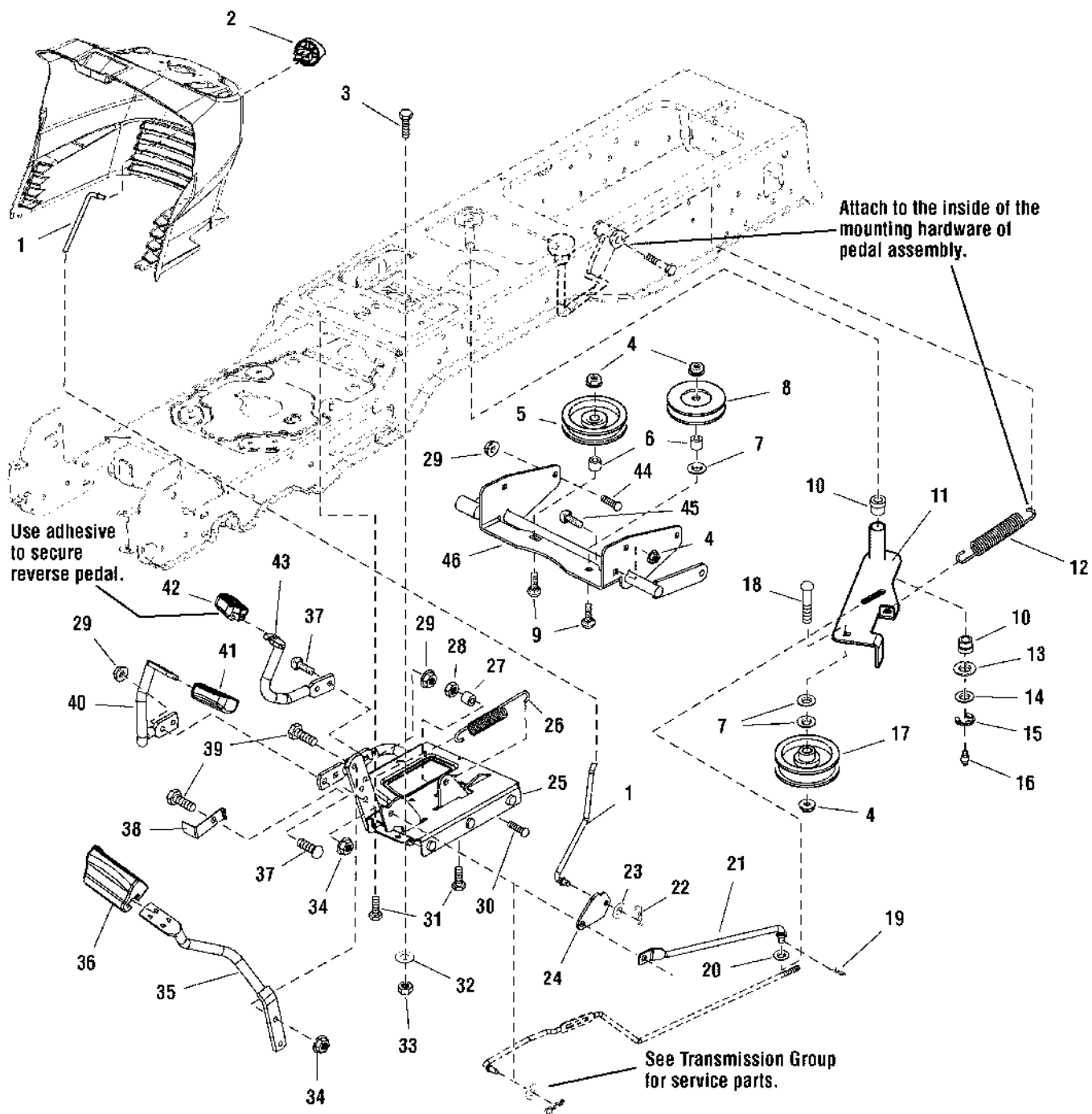

The above parts group applies to the following Mfg. Nos.:

- 2690621 - Baron XL
- 2690622 - Baron XL
- 2690625 - 2420 XL
- 2690762 - Baron
- 2690772 - 2421

Controls Group

REF NO	PART NO.	QTY.	DESCRIPTION
45	1931348SM	1	CARRIAGE BOLT, 3/8-16 x 3/4
46	1726087ASM	1	SUPPORT, Idler

Not for
Reproduction

Footnotes

The above parts group applies to the following Mfg. Nos.:

2690621 - Baron XL
2690622 - Baron XL
2690625 - 2420 XL
2690762 - Baron
2690772 - 2421

Electrical Group

986631

NOTE: Unless noted otherwise, use the standard hardware torque specification chart.

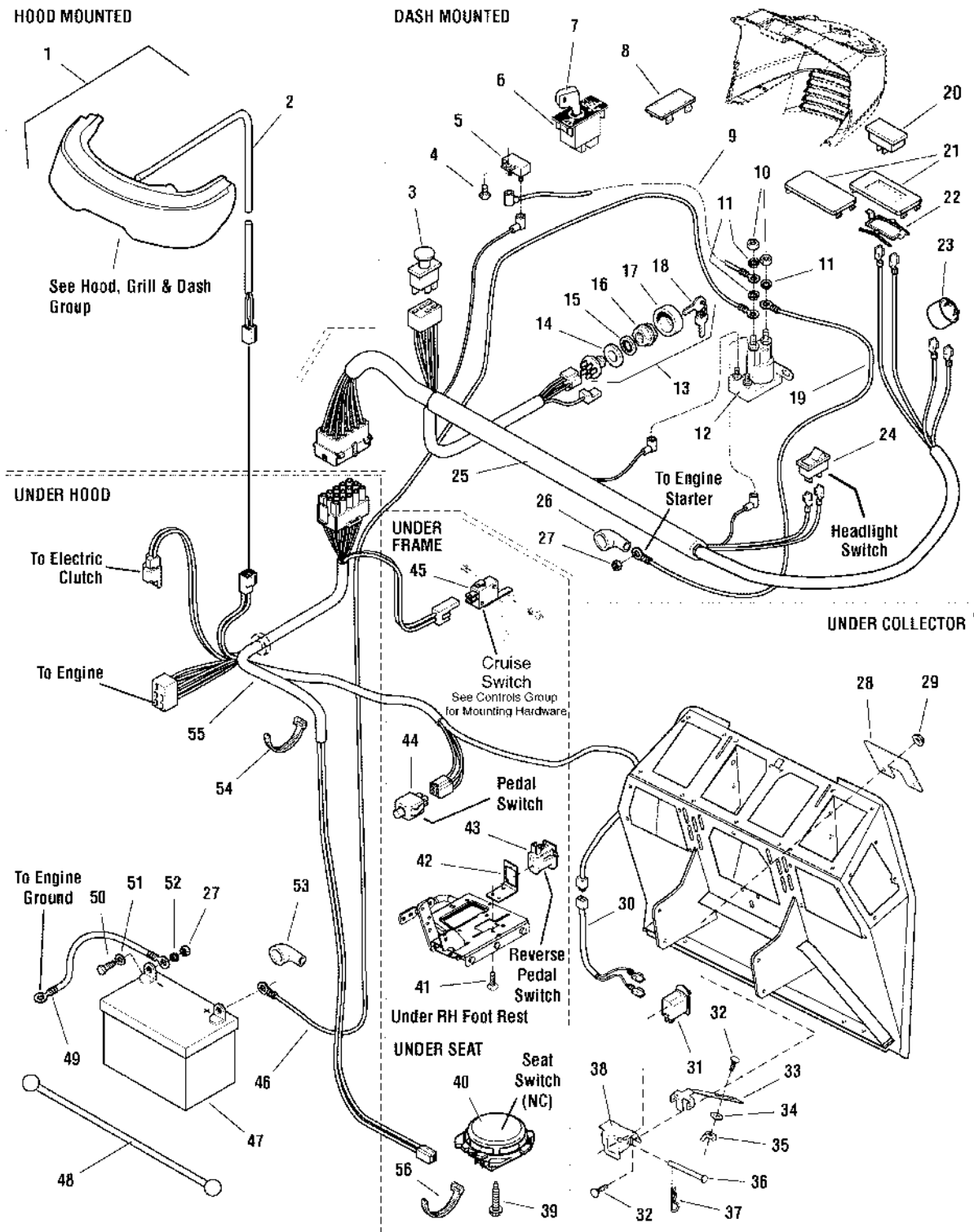

The above parts group applies to the following Mfg. Nos.:

- 2690621 - Baron XL
- 2690622 - Baron XL
- 2690625 - 2420 XL
- 2690762 - Baron
- 2690772 - 2421

Electrical Group

REF NO	PART NO.	QTY.	DESCRIPTION
1	1721810SM	1	HEADLIGHT ASSEMBLY, 4 Bulb
2	1722669SM	1	HARNESS, Headlight
3	1722887SM	1	SWITCH, PTO Push/Pull w/Symbols
4	1921959SM	1	CAPSCREW, Hex Head, 1/4 x 5/8
5	1722739SM	1	SOLENOID
6	1726556SM	1	SWITCH, RMO Module Only
7	1726557SM	1	KEY, RMO Module, Plastic
8	1722611SM	1	PLUG, Hole Black
9	1665237SM	1	WIRE, 12GA 8 Long Red
10	2820263SM	2	NUT, Hex, 5/16-24 NF-2B
11	2820426SM	3	LOCKWASHER, External Tooth 5/16
12	1665238SM	1	BREAKER, Circuit 12VOLT 20AMPS w/Tabs
13	1686734SM	1	SWITCH ASSEMBLY, Ingition, 6 Pin Indak (Includes Ref. Nos. 14 thru 18)
14	2101025SM	1	WASHER, 5/8
15	1960547SM	1	LOCKWASHER, Internal Tooth, 5/8
16	1717549SM	1	NUT, Hex Flange, 5/8-32 Ignition Switch
17	1717550SM	1	COVER, Ignition Switch, Black
18	1717163SM	1	KEYS, Ignition Set of 2
19	1721830SM	1	CABLE, # 6 x 25 Long Red, 2 Ring Terminals
20	1731184SM	1	METER, Hour Digital w/Oil & Lube Alarms
21	1725524SM	1	PLUG, Dash, Hour Meter
21	1725698SM	1	PLUG, Dash, No Hour Meter Hole
22	1725835SM	1	CLIP, Hour Meter, Holds In Daash
23	1720117SM	1	BUZZER, Pulse, Grass Bag Full
24	1716951SM	1	SWITCH, Headlights, 2 Terminal
25	1730195SM	1	HARNESS, Wiring Upper
26	1677296SM	1	BOOT, Insulator, Battery Terminal
27	2816622SM	3	NUT, Hex, 1/4-20 NC-2B
28	1727776ASM	1	DEFLECTOR, Switch 14GA
29	1960685SM	2	NUT, Hex KEPS Conical Washer, 1/4-20
30	1723954SM	1	HARNESS, Wiring Rear
31	1720411SM	1	SWITCH, Push Button w/Boot, Bagger
32	1960252SM	3	CARRIAGE BOLT, 1/4-20 x 5/8 G5
33	1727428SM	1	PIVOT, Actuator 14GA, E-Coat
34	1960103SM	1	WASHER, 3/8
35	2860293SM	1	NUT, Wing Lock, 1/4-20
36	1960607SM	1	PIN, Clevis
37	1960221SM	1	CLIP, Hair Pin
38	1727427SM	1	SUPPORT, Actuator 14GA, E-Coat
39	1960536SM	2	SCREW, Hex Washer Head Plastite, 1/4 x 1/2 (Used only on Seat Switch 1716368SM)
40	1716368SM	1	SWITCH, Operator Presents, Seat (Mounted with screw Syte)
40	1718981SM	1	SWITCH, Operator Presents, Seat (Twist in Style)
41	1929000SM	1	SCREW, Hex Washer Head Taptite, 1/4-20 x 3/8

Footnotes

The above parts group applies to the following Mfg. Nos.:

2690621 - Baron XL
2690622 - Baron XL
2690625 - 2420 XL
2690762 - Baron
2690772 - 2421

Electrical Group

986631

NOTE: Unless noted otherwise, use the standard hardware torque specification chart.

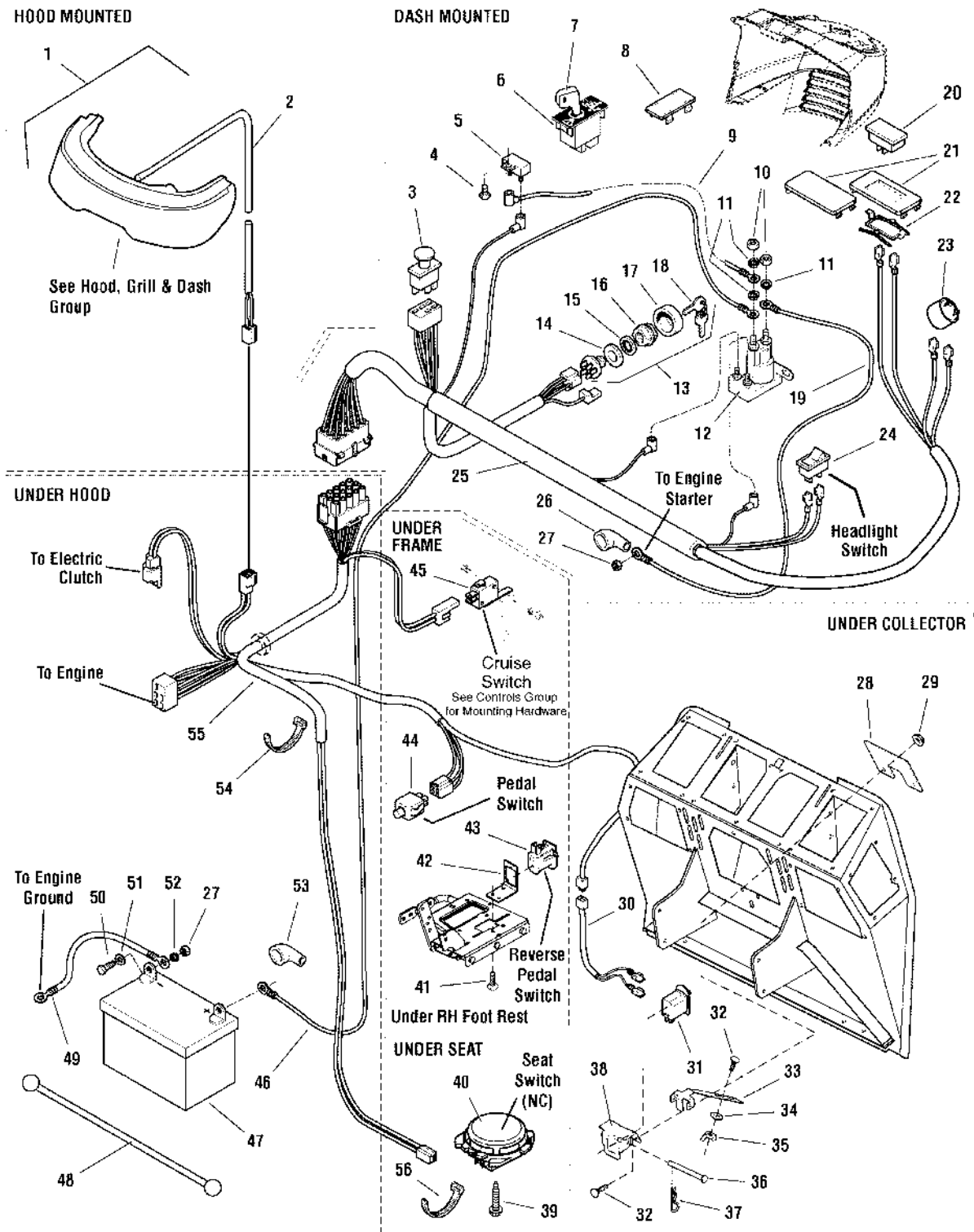

The above parts group applies to the following Mfg. Nos.:

- 2690621 - Baron XL
- 2690622 - Baron XL
- 2690625 - 2420 XL
- 2690762 - Baron
- 2690772 - 2421

Electrical Group

REF NO	PART NO.	QTY.	DESCRIPTION
42	1726810ASM	1	BRACKET, Switch Mounting, RMO
43	1732004SM	2	SWITCH, Push Button, Reverse Pedal
44	1723507SM	1	SWITCH, Push Button, Foot Pedal
45	1717050SM	1	SWITCH, Push Button, Cruise Control
46	1603618SM	1	CABLE, # 6 x 9 Long, 2 Ring Terminals
47	1685215SM	1	BATTERY, 12VOLT 6CELL 230AMPS CCA
48	1722009SM	1	STRAP, Battery 14 Long, Black Rubber
49	1713163SM	1	CABLE, # 6 x 26 Long Black, 2 Ring Terminals
50	2823341SM	2	CAPSCREW, Hex Head, 1/4-20 x 3/4 G5
51	2821319SM	2	WASHER, 1/4
52	2816964SM	2	LOCKWASHER, Spring 1/4
53	1713535SM	1	BOOT, Insulator Red, Cable Terminal
54	1701011SM	4	TIE, Self Locking, 7-5/16
55	1730194SM	1	HARNESS, Wiring Lower
56	2825094SM	1	TIE, Self Locking (Used only on Seat Switch 1718981SM)

Not for
Reproduction

Footnotes

The above parts group applies to the following Mfg. Nos.:

2690621 - Baron XL
2690622 - Baron XL
2690625 - 2420 XL
2690762 - Baron
2690772 - 2421

Hood, Grille & Dash Group

986611

NOTE: Unless noted otherwise,
use the standard hardware torque
specification chart.

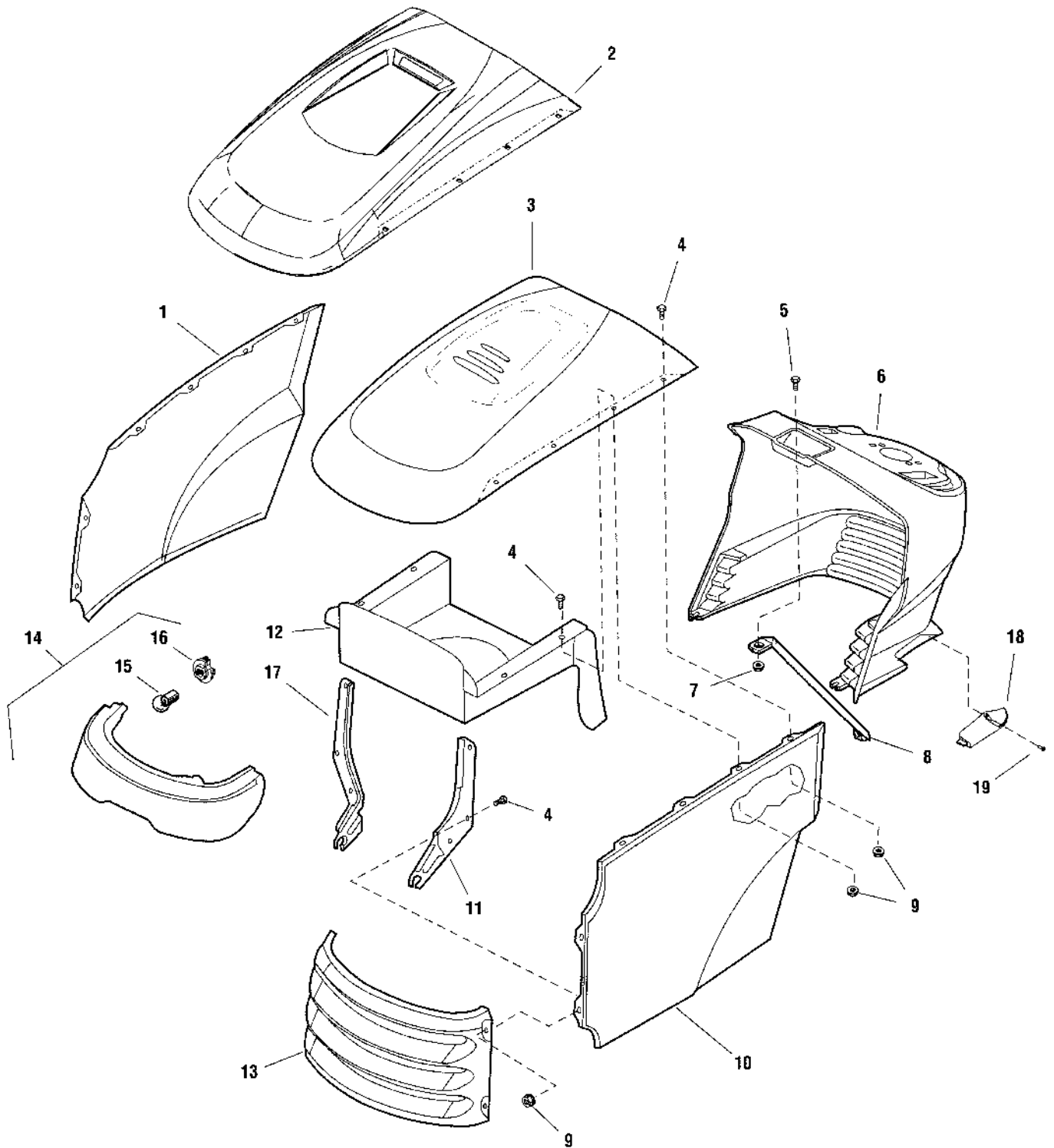

The above parts group applies to the following Mfg. Nos.:

2690621 - Baron XL
2690622 - Baron XL
2690625 - 2420 XL
2690762 - Baron
2690772 - 2421

Hood, Grille & Dash Group

REF NO	PART NO.	QTY.	DESCRIPTION
1	1721804CSM	1	PANEL, RH Side
1	1721804DSM	1	PANEL, RH Side, Red
2	1728031DSM	1	HOOD, with Scoop
3	1722110CSM	1	HOOD, with Louvers
4	1960295SM	12	CAPSCREW, Hex Head Flange Lock, 1/4-20 x 5/8
5	1960392SM	1	SCREW, Phillips Head, #10-24 x 1/2
6	1687056SM	1	DASHBOARD, RMO with Buzzer Hole, Black
7	1933896SM	1	NUT, Hex Nylock, #10-24
8	1723123SM	1	ROD, Dash Support
9	1930641SM	12	NUT, Hex Flange Lock, 1/4-20
10	1721803CSM	1	PANEL, LH Side
10	1721803DSM	1	PANEL, LH Side, Red
11	1721808ASM	1	HINGE, LH
12	1733457ASM	1	DUCT, Air Inlet
13	1721802CSM	1	GRILLE
13	1721802DSM	1	GRILLE, Red
14	1721810SM	1	HEADLIGHT ASSEMBLY, (Includes Ref. Nos. 15 & 16)
15	1677371SM	4	BULB, Headligh
16	1723451SM	4	SOCKET, Headlight
17	1721809ASM	1	HINGE, RH
18	1722285SM	1	COVER, Lift
19	1722607SM	1	SCREW, Plastite #8-16 x 1/2

Not for
Reproduction

Footnotes

The above parts group applies to the following Mfg. Nos.:

2690621 - Baron XL
2690622 - Baron XL
2690625 - 2420 XL
2690762 - Baron
2690772 - 2421

Seat Deck & Fuel Tank Group

986812

NOTE: Unless noted otherwise,
use the standard hardware torque
specification chart.

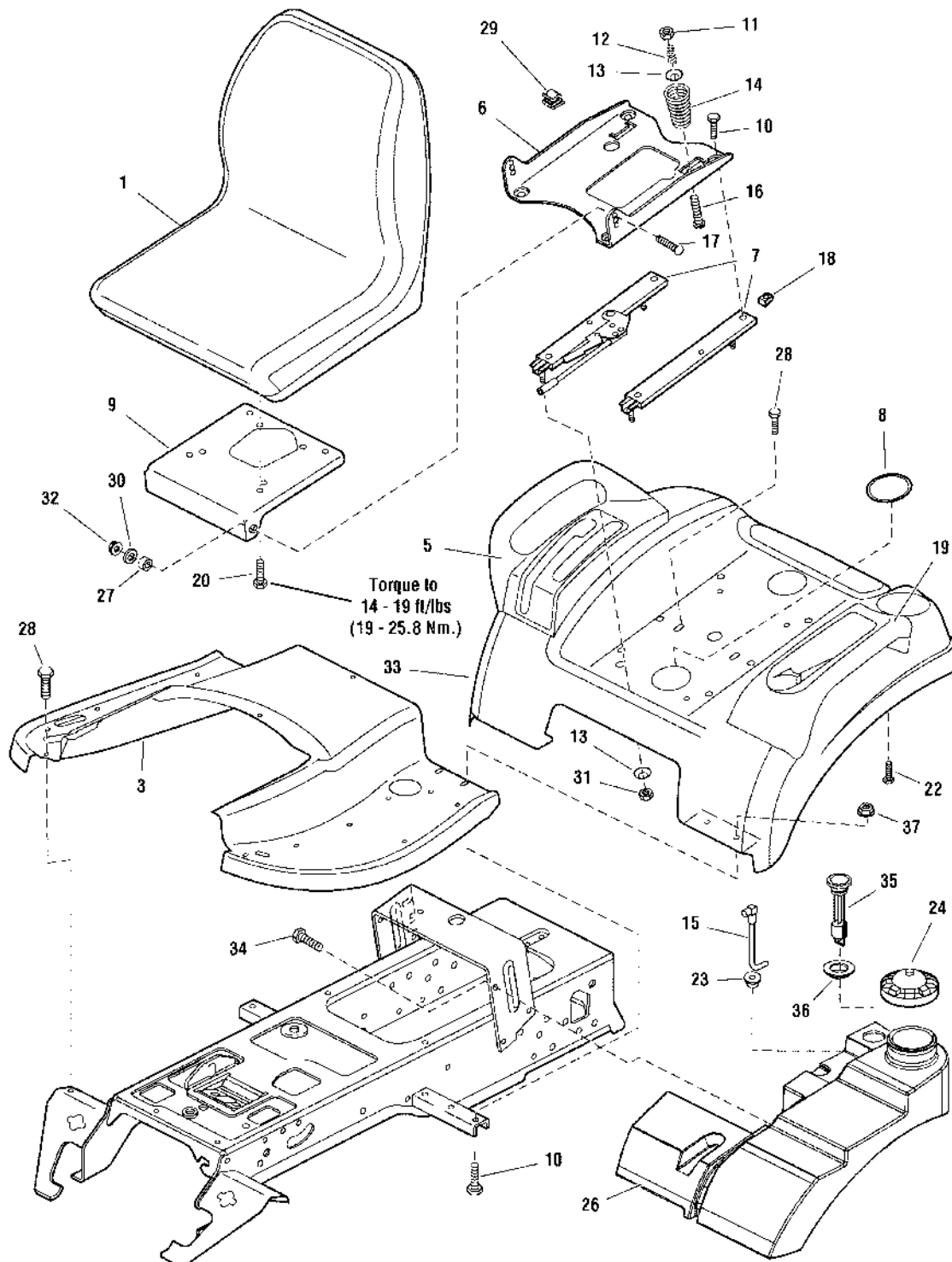

The above parts group applies to the following Mfg. Nos.:

- 2690621 - Baron XL
- 2690622 - Baron XL
- 2690625 - 2420 XL
- 2690762 - Baron
- 2690772 - 2421

Seat Deck & Fuel Tank Group

REF NO	PART NO.	QTY.	DESCRIPTION
1	1687201SM	1	SEAT, 15" Back
3	1722105CSM	1	TUNNEL, Orange
3	1722105DSM	1	TUNNEL, Red
5	1722108SM	1	POD, R.H.
6	1722128ASM	1	SUPPORT, Seat
7	1722356SM	1	SLIDE, Seat
8	1722309SM	2	PLUG, Hole
9	1722129ASM	1	BRACKET, Seat
10	1930591SM	8	SCREW, Hex Whiz Lock Flange 5/16-18 x 3/4
11	1919438SM	2	NUT, Hex Lock Esna Light 5/16-18
12	1714263SM	2	SPRING, Compression
13	1709256SM	6	WASHER, Spring
14	1717051SM	2	SPRING
15	1726902SM	1	TUBE & ELBOW ASSEMBLY, Fuel Line w/Screen
16	1931339SM	2	CARRIAGE BOLT, 5/16-18 x 2 G5
17	1931350SM	2	CARRIAGE BOLT, 3/8-16 x 1 G5
18	1935255SM	4	NUT, Speed, 5/16-18 Lug Type
19	1729711SM	1	POD, w/Cup Holder
20	1960667SM	4	SCREW, Hex Flange, Whiz Lock 5/16-18 x 1
22	2860664SM	8	SCREW, Hex Sems Washer 1/4c x 7/8
23	1654930SM	1	BUSHING, Fuel Tank FUEL TANK
24	1715917SM	1	CAP, Fuel Tank
26	1722652SM	1	TANK, Fuel
27	1663752SM	2	SPACER
28	1930601SM	2	SCREW, Hex Washer Head Taptite 5/16-18 x 5/8
29	2172434SM	1	CLIP, Wire, Panel
30	1924940SM	2	WASHER, 3/8
31	1919438SM	4	NUT, Hex Lock Esna Light 5/16-18
32	1930645SM	2	NUT, Hex Flange 3/8-16 Two-Way Lock
33	1727397CSM	1	DECK, Seat Orange
33	1727397DSM	1	DECK, Seat Red
34	2834665SM	1	SCREW, Hex Whiz Lock Flange 5/16-18 x 5/8
35	1722300SM	1	FUEL, Gauge
36	1722337SM	1	GROMMET
37	1931277SM	4	NUT, Hex Flange 5/16-18 Whiz Lock Small

Footnotes

The above parts group applies to the following Mfg. Nos.:

2690621 - Baron XL
 2690622 - Baron XL
 2690625 - 2420 XL
 2690762 - Baron
 2690772 - 2421

Hopper Group

986813

NOTE: Unless noted otherwise,
use the standard hardware torque
specification chart.

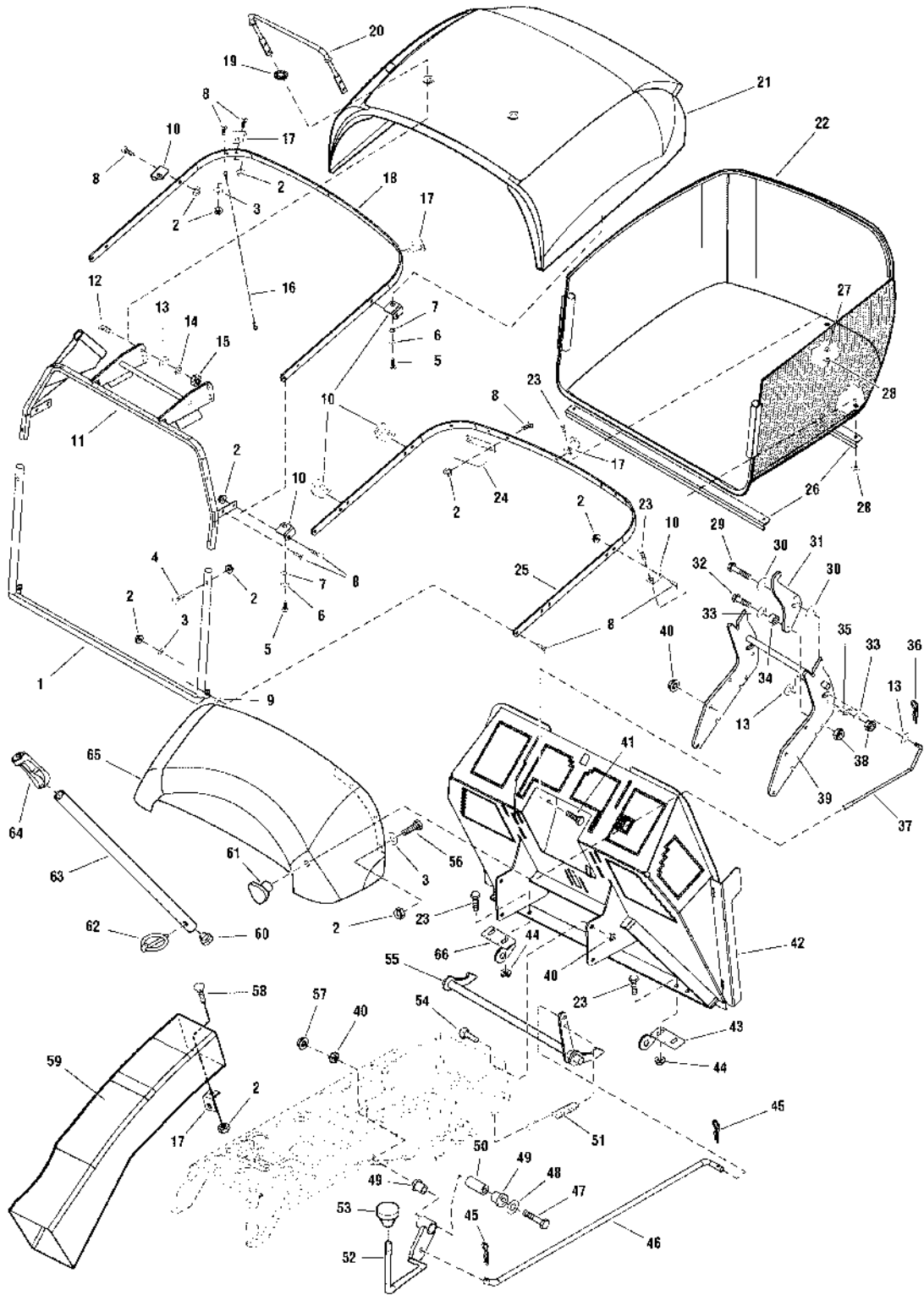

The above parts group applies to the following Mfg. Nos.:

- 2690621 - Baron XL
- 2690622 - Baron XL
- 2690625 - 2420 XL
- 2690762 - Baron
- 2690772 - 2421

Hopper Group

REF NO	PART NO.	QTY.	DESCRIPTION
1	1727486ASM	1	ROD & TABS ASSEMBLY, Bagger Front
2	1960685SM	22	NUT, Hex KEPS Conical Washer, 1/4-20
3	1960353SM	8	WASHER, 1/4
4	1931320SM	4	CARRIAGE BOLT, 1/4-20 x 1-1/4
5	1921333SM	6	CAPSCREW, Hex Head, 5/16-18 x 1 G5
6	1917356SM	6	LOCKWASHER, Spring 5/16
7	1919326SM	6	WASHER, 5/16
8	1931317SM	15	CARRIAGE BOLT, 1/4-20 x 3/4 G5
9	1715654SM	2	SPACER
10	1727674SM	6	CLIP, L 12GA
11	1727420ASM	1	FRAME ASSEMBLY, Hopper
12	1924009SM	4	CAPSCREW, Hex Head, 1/4-20 x 7/8 G5
13	1921319SM	3	WASHER, 1/4
14	1916964SM	4	LOCKWASHER, Spring 1/4
15	1916622SM	4	NUT, Hex 1/4-20
16	1727832SM	2	CABLE, Bagger, 17.72 Long
17	1727676ASM	4	CLIP, L 12GA
18	1727671ASM	1	BAR, Bagger Top 7GA
19	1724684SM	2	WASHER, 5/8
20	1724399ASM	1	HANDLE, Hopper, 13.59 Long
21	1727930SM	1	LID & SCREEN ASSEMBLY, Orange
21	1727931SM	1	LID & SCREEN ASSEMBLY, Red
22	1727423SM	1	BAG, Grass Black Cloth
23	1931334SM	9	CARRIAGE BOLT, 5/16-18 x 7/8 G5
24	1727520ASM	1	PLATE, Tube Stop Bagger 14GA
25	1727670ASM	1	BAR, Bagger Bottom 7GA
26	1727675ASM	2	BRACE, Angle
27	1960044SM	1	WASHER, 5/16
28	1960684SM	5	NUT, Hex KEPS Conical Washer, 5/16-18
29	1921978SM	1	CAPSCREW, Hex Head 5/16-18 x 2 G5
30	1960044SM	2	WASHER, 5/16
31	1724651ASM	1	LATCH, Release 10GA
32	1921333SM	1	CAPSCREW, Hex Head, 5/16-18 x 1 G5
33	1919326SM	2	WASHER, 5/16
34	1666697SM	1	SPACER, Powdered Metal
35	1714263SM	1	SPRING, Compression
36	1923360SM	1	PIN, Cotter
37	1724652SM	1	ROD, Foot Pedal Bagger Release, 11.66 Long, 2 Bends
38	1919438SM	2	NUT, Hex Lock ESNA Light, 5/16-18 NC-3B
39	1727580ASM	1	PIVOT ASSEMBLY, Latch
40	1928352SM	5	NUT, Hex Flange Whiz Lock, 3/8-16 Large
41	1921965SM	4	CAPSCREW, Hex Head, 3/8-16 x 3/4 G5
42	1727419ASM	1	BACKPLATE ASSEMBLY
43	1723182ASM	1	BRACKET, Latch LH, 7GA

Footnotes

The above parts group applies to the following Mfg. Nos.:

2690621 - Baron XL
2690622 - Baron XL
2690625 - 2420 XL
2690762 - Baron
2690772 - 2421

Hopper Group

986813

NOTE: Unless noted otherwise,
use the standard hardware torque
specification chart.

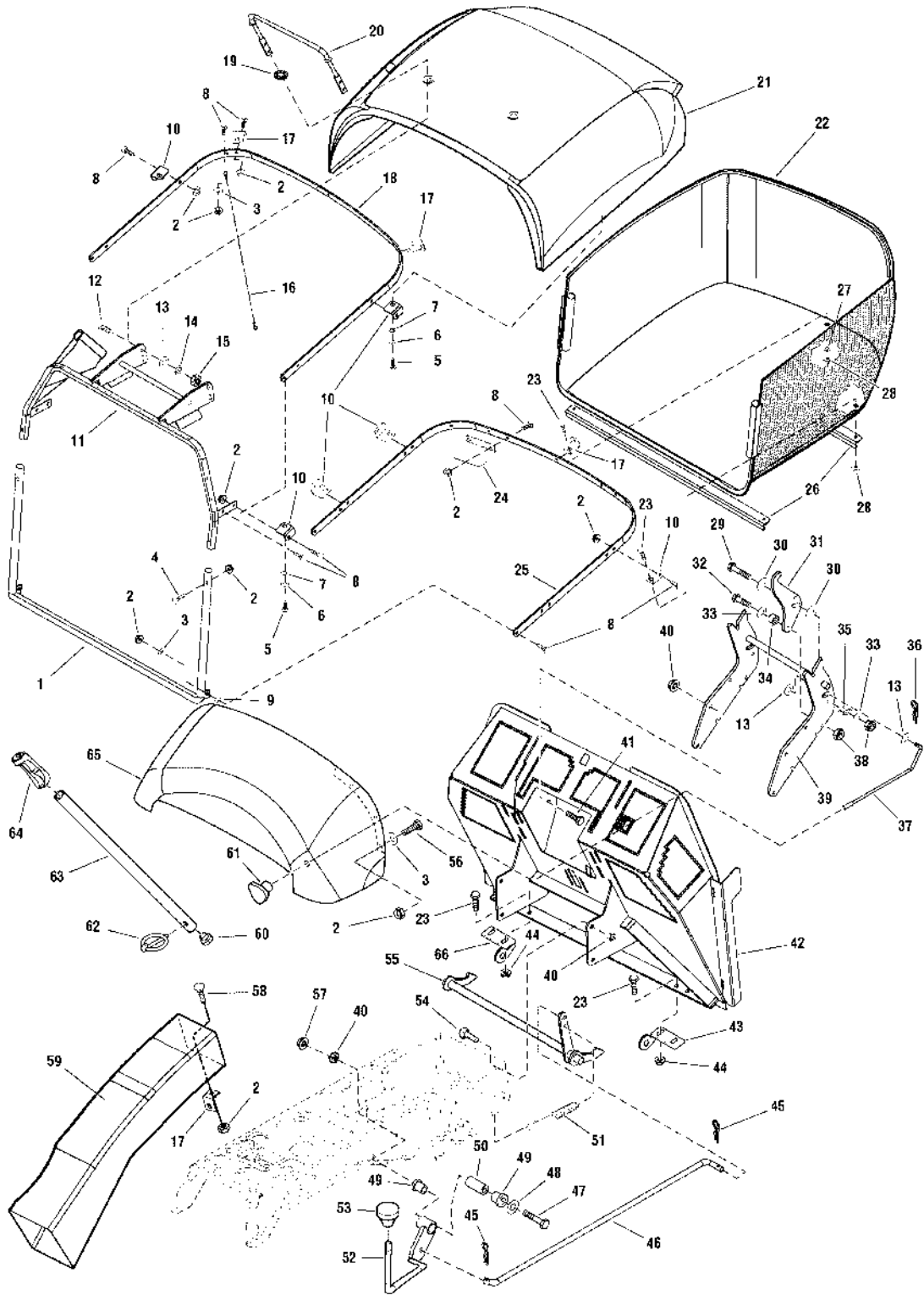

The above parts group applies to the following Mfg. Nos.:

- 2690621 - Baron XL
- 2690622 - Baron XL
- 2690625 - 2420 XL
- 2690762 - Baron
- 2690772 - 2421

Hopper Group

REF NO	PART NO.	QTY.	DESCRIPTION
44	1931277SM	4	NUT, Hex Flange Whiz Lock, 5/16-18 Small
45	1960074SM	2	CLIP, Hair Pin, Spring Wire
46	1724458SM	1	ROD, 25.12 Long, 2 Bends
47	1921973SM	1	CAPSCREW, Hex Head, 3/8-16 x 2-3/4 G5
48	1924940SM	1	WASHER, 3/8
49	1676148SM	2	BUSHING, Powdered Metal
50	1669105SM	1	SPACER, 1-1/2 Long, Hardened
51	1718016SM	1	SPRING, Extension
52	1725036SM	1	ROD & TUBE ASSEMBLY, Differential Lock Pedal
53	1719940SM	1	KNOB, Hole 1/2, 1.37 Long
54	1960268SM	4	CARRIAGE BOLT, 3/8-16 x 1-1/4 G5
55	1724540SM	1	SHAFT & ARMS ASSEMBLY, Latch
56	1960556SM	4	SCREW, Pan Head Torx Taptite, 1/4-20 x 3/4
57	1930645SM	1	NUT, Hex Flange Two Way Lock, 3/8-16 GA
58	1923341SM	1	CAPSCREW, Hex Head, 1/4-20 x 3/4 G5
59	1727429SM	1	CHUTE, Discharge Black Poly
60	1724553SM	1	CAPLUG, Black Poly, 3/4 Hole
61	1713855SM	1	KNOB, Bagger Release
62	1666969SM	1	PIN, Klik 5/164
63	1727523ASM	1	HANDLE, Tube, 39.75 Long
64	1723359SM	1	GRIP, Hopper Lift Rod
65	1727406SM	1	TRANSITION, Hopper Black
66	1723181ASM	1	BRACKET, Latch RH, 7GA

Not for
Reproduction

Footnotes

The above parts group applies to the following Mfg. Nos.:

2690621 - Baron XL
2690622 - Baron XL
2690625 - 2420 XL
2690762 - Baron
2690772 - 2421

Wheels & Tires Group

W986625

NOTE: Unless noted otherwise,
use the standard hardware torque
specification chart.

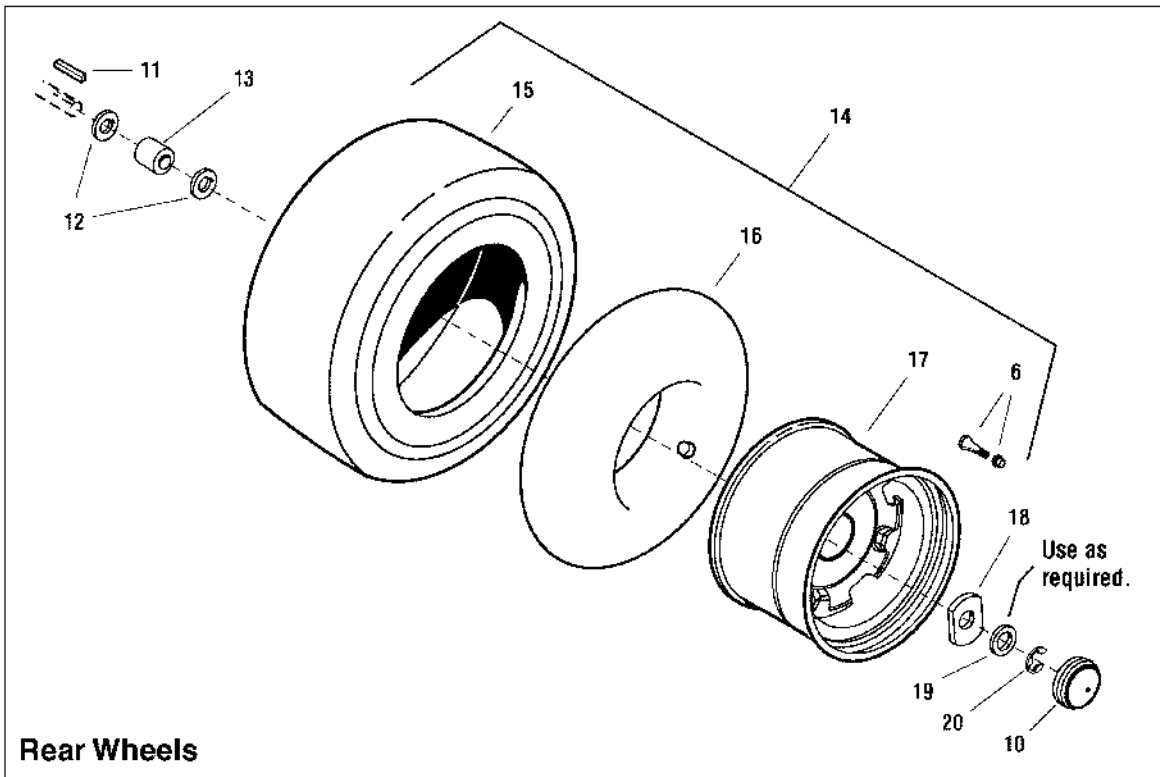
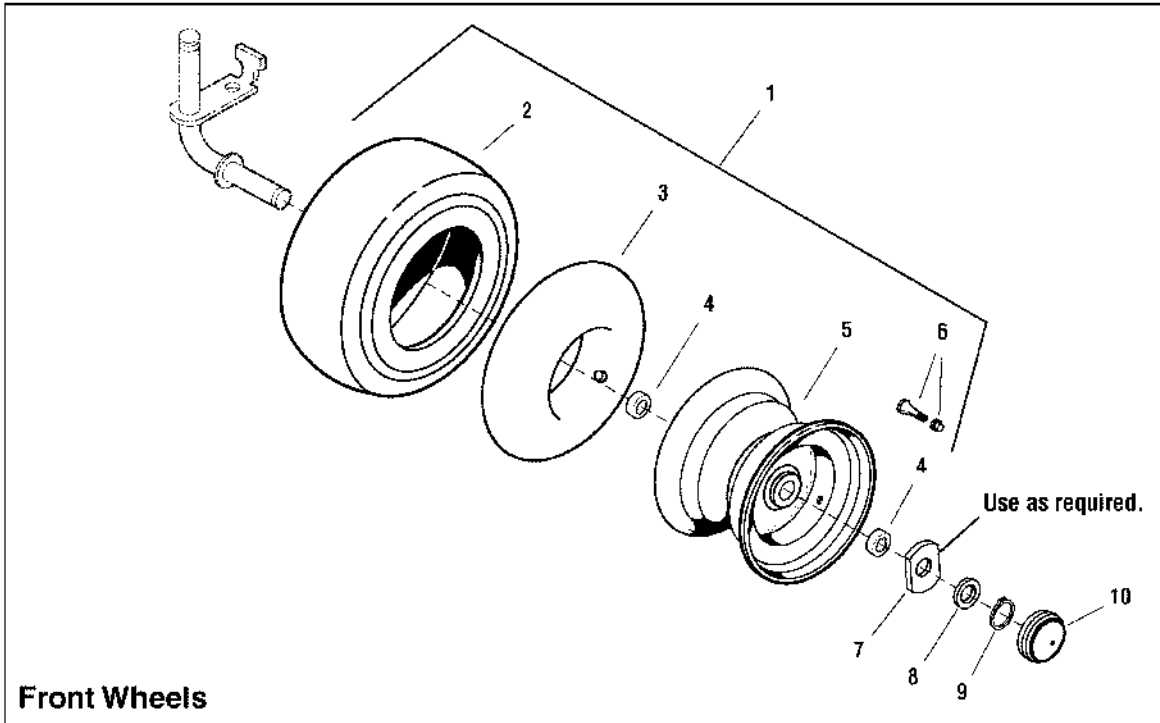

The above parts group applies to the following Mfg. Nos.:

- 2690621 - Baron XL
- 2690622 - Baron XL
- 2690625 - 2420 XL
- 2690762 - Baron
- 2690772 - 2421

Wheels & Tires Group

REF NO	PART NO.	QTY.	DESCRIPTION
1	1732202SM	2	WHEEL & TIRE ASSEMBLY, Front, (Includes Ref. Nos. 2, 3, 4, 5, & 6)
2	1733882SM	1	TIRE, 15 x 6, Super Turf
3	1664090SM	1	TUBE, Tire, Front, 4.10/3.50
4	1717056SM	2	BEARING, Ball
5	1722837SM	1	WHEEL, 4-1/2" x 6"
6	2172353SM	4	VALVE STEM & CAP ASSEMBLY
7	1722726SM	4	WASHER, Special, (As Required)
8	1919394SM	4	WASHER, 1, (As Required)
9	2832577SM	2	RING, Retaining, External #98
10	1722676SM	4	CAP, Hub, Gray
11	1729279SM	2	KEY, Parellel, 3/16 x 3/16 x 1-1/2
12	2860202SM	4	WASHER, 3/4
13	1709527SM	2	SPACER
14	1732203SM	2	WHEEL & TIRE ASSEMBLY, (Includes Ref. Nos. 6, 15, 16 & 17)
15	1733881SM	1	TIRE, 20 x 10, 8 Super Turf
16	2173477SM	1	TUBE, Tire, 20 x 8, Rear
17	1722835SM	1	WHEEL, 7 x 7.96, W/ 3/4 OD Shaft
18	1722717SM	2	WASHER, Special
19	1960114SM	2	WASHER, 3/4
20	2827794SM	2	RING, "E" External

Not for
Reproduction

Footnotes

The above parts group applies to the following Mfg. Nos.:

2690621 - Baron XL
2690622 - Baron XL
2690625 - 2420 XL
2690762 - Baron
2690772 - 2421

Decals Group - Brand & Model

NOTE: Unless noted otherwise,
use the standard hardware torque
specification chart.

B986625

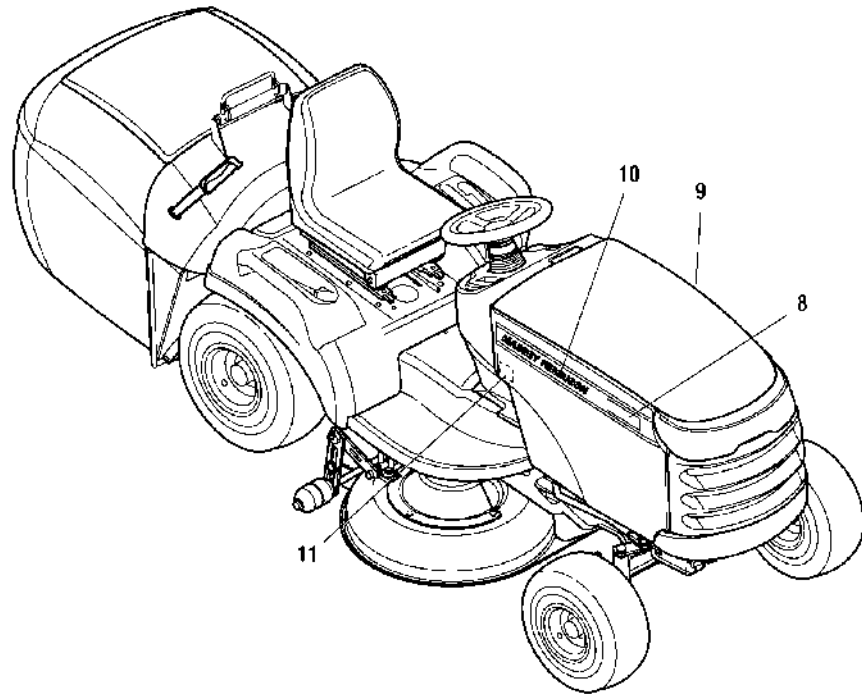
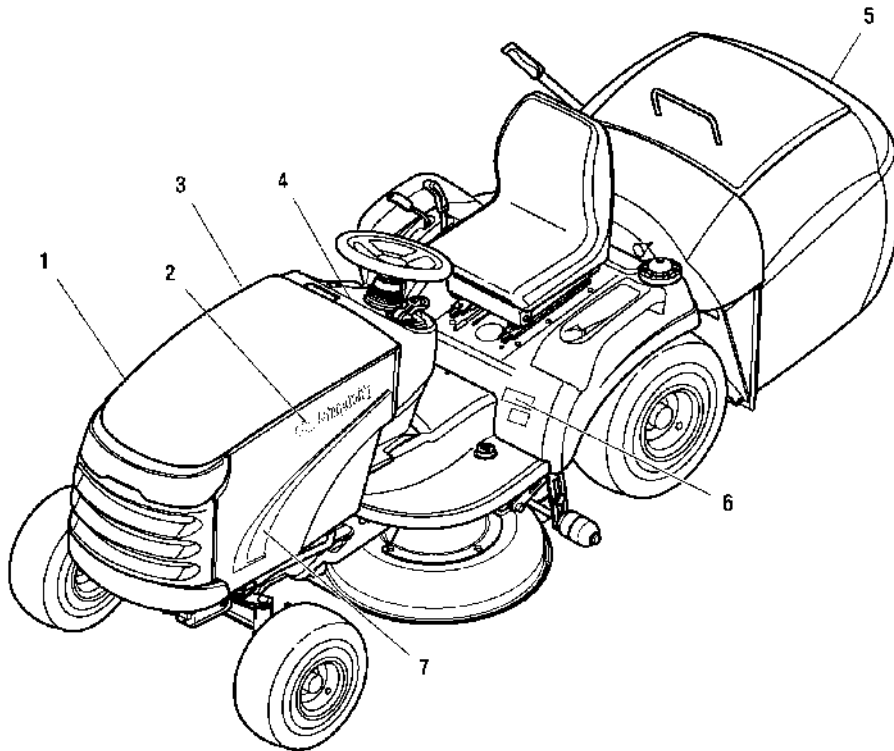

The above parts group applies to the following Mfg. Nos.:

2690621 - Baron XL
2690622 - Baron XL
2690625 - 2420 XL
2690762 - Baron
2690772 - 2421

Decals Group - Brand & Model

REF NO	PART NO.	QTY.	DESCRIPTION
1	1722773SM	1	DECAL, Hood Stripe RH, Simplicity
1	1727784SM	1	DECAL, Hood Stripe RH, Massey Baron
2	1727718SM	1	DECAL, Hood LH, Simplicity
3	1727717SM	1	DECAL, Hood RH, Simplicity
4	1727714SM	1	DECAL, Baron XL
5	1723859SM	1	DECAL, Simplicity
6	1722784SM	1	DECAL, Baron
7	1722774SM	1	DECAL, Hood Stripe LH, Simplicity
8	1728095SM	2	DECAL, 2420 Massey Ferguson
8	1728121SM	2	DECAL, 2418 Massey Ferguson
8	1728121SM	2	DECAL, 2421 Massey Ferguson
9	1727784SM	1	DECAL, Hood Stripe LH, Massey Ferguson
9	1727783SM	1	DECAL, Hood Stripe LH, Massey Baron
10	1722774SM	1	DECAL, Hood Stripe LH, Simplicity
11	1720454SM	1	DECAL, Touch Up Paint (Orange & Red)

Not for
Reproduction

Footnotes

The above parts group applies to the following Mfg. Nos.:

2690621 - Baron XL
2690622 - Baron XL
2690625 - 2420 XL
2690762 - Baron
2690772 - 2421

Decals Group - Safety & Common

NOTE: Unless noted otherwise,
use the standard hardware torque
specification chart.

C986625

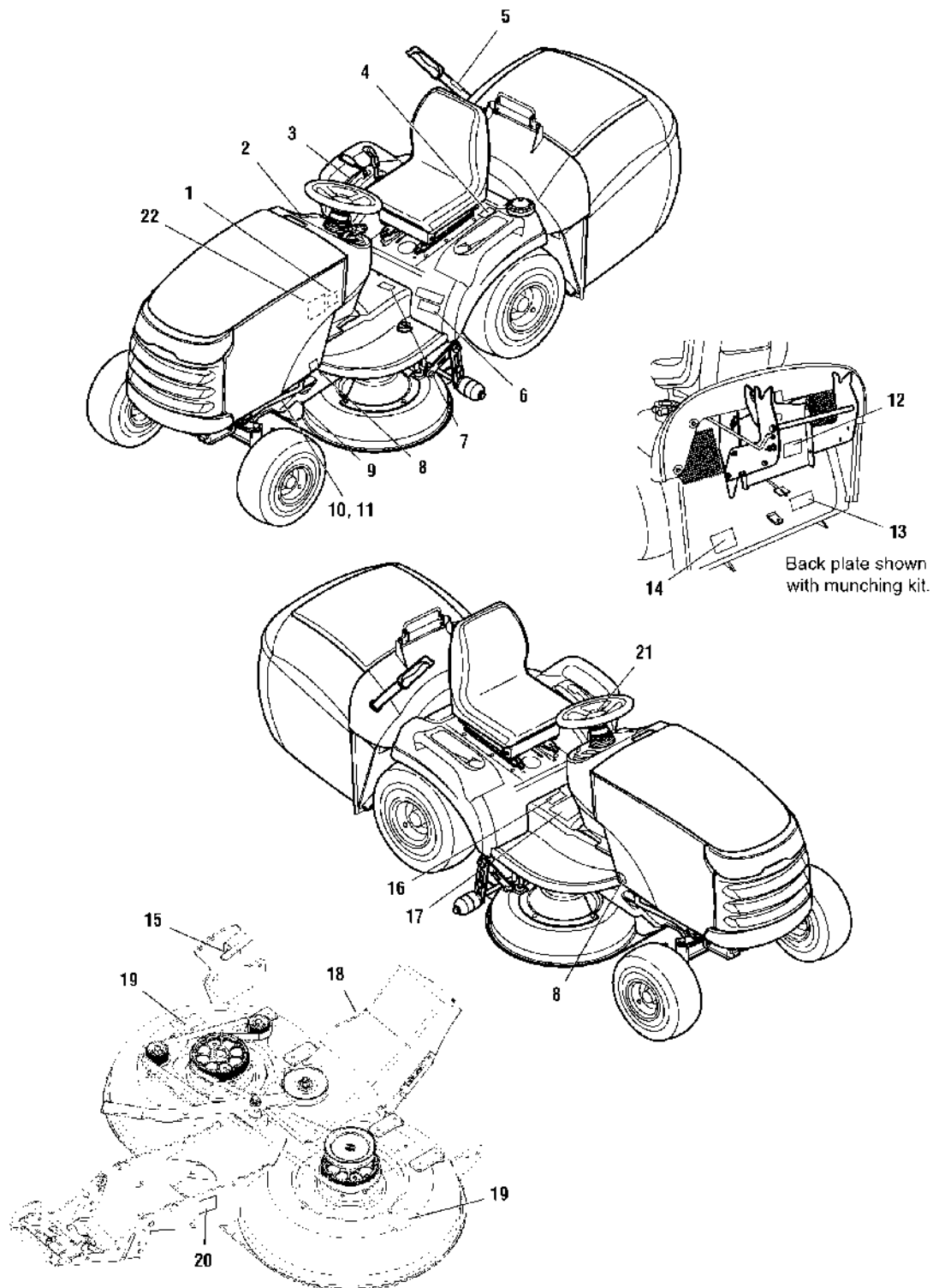

The above parts group applies to the following Mfg. Nos.:

- 2690621 - Baron XL
- 2690622 - Baron XL
- 2690625 - 2420 XL
- 2690762 - Baron
- 2690772 - 2421

Decals Group - Safety & Common

REF NO	PART NO.	QTY.	DESCRIPTION
1	1732413SM	1	DECAL, Belt and Blade
2	1722806SM	1	DECAL, Ignitiaon Switch Symbols
3	1723713SM	1	DECAL, Cruise/Lift
4	1724680SM	1	DECAL, Hopper Release
5	1723310SM	1	DECAL, Hopper Lever
6	1722779SM	1	DECAL, 18HP
6	1722780SM	1	DECAL, 20HP
6	1730206SM	1	DECAL, 21HP
7	1723317SM	1	DECAL, Hopper Pedal
8	1723296SM	2	STICKER, Protective Clear, 1-3/4 x 1-3/4
9	*	2	LABEL, Decibel
10	*	1	ID PLATE, Tractor
11	*	1	DECAL, Patent
12	1723425SM	1	DECAL, Transmission Release Valve, Symbol
13	1721141SM	1	DECAL, Drawbar Max Load
14	1720391SM	1	DECAL, Danger Operating without Catcher
15	1723470SM	1	DECAL, Height of Cut
16	1720390SM	1	DECAL, Danger Catcher Open, Symbol
17	1723175SM	1	DECAL, Operator Tunnel Icons (CE/Export)
17	1734027SM	1	DECAL, Operator Tunnel Icons ACS (CE/Export)
18	1721107SM	1	DECAL, Danger Discharge Tube, Symbols (Right side of discharge chute)
19	1720389SM	2	DECAL, Danger Rotating Blades, Symbols
20	*	1	ID PLATE, Mower Deck
21	1731418SM	1	DECAL, SMI Steering Wheel, Orange
22	1720454SM	1	DECAL, Touch Up Paint, Orange, Black, Red

Footnotes

Note* Not a serviceable part.

The above parts group applies to the following Mfg. Nos.:

2690621 - Baron XL
2690622 - Baron XL
2690625 - 2420 XL
2690762 - Baron
2690772 - 2421

40" Mower Deck - Belt, Idle Arm & Hitch

986896

NOTE: Unless noted otherwise, use the standard hardware torque specification chart.

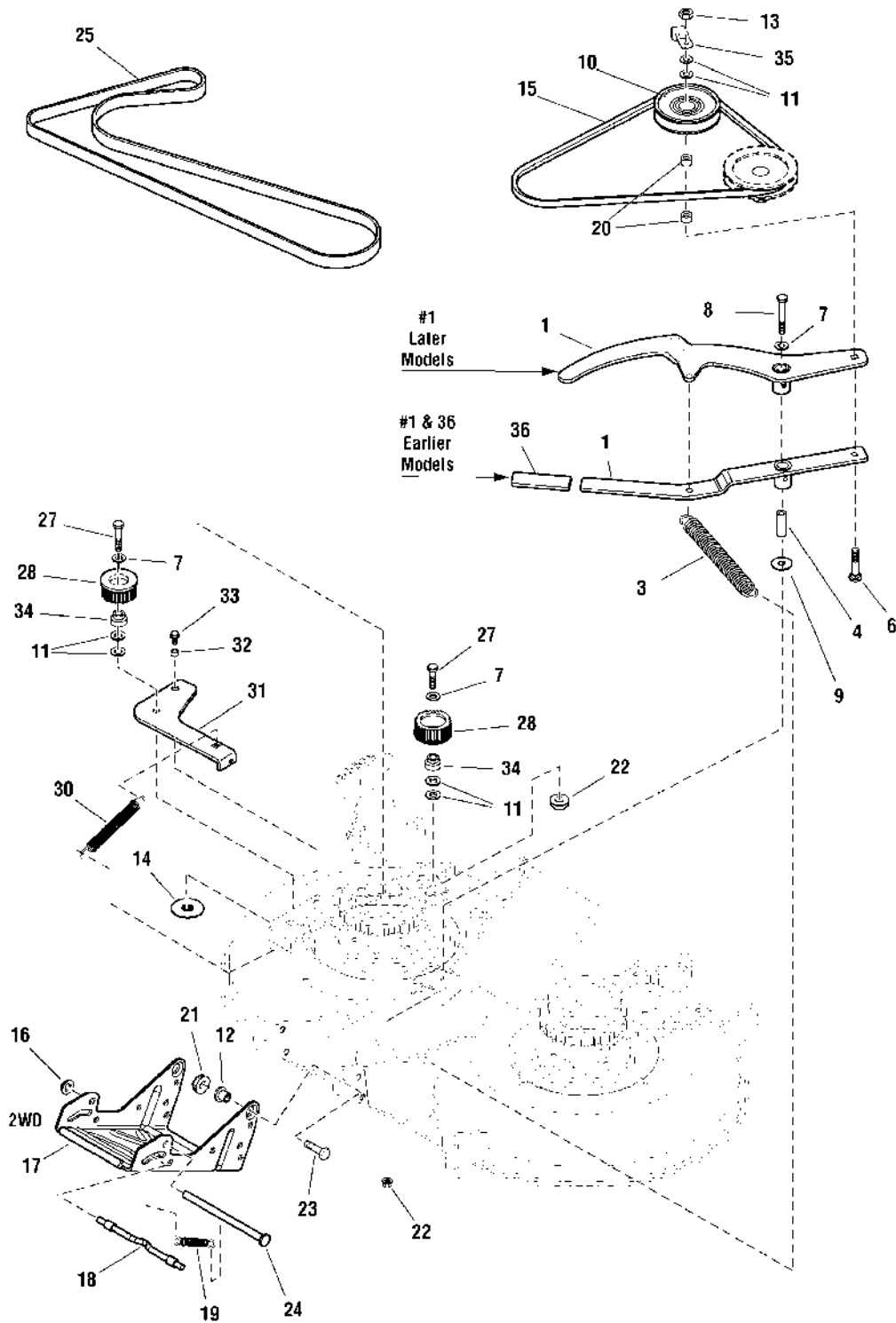

The above parts group applies to the following Mfg. Nos.:

- | | |
|---------------------|-----------------|
| 1695200 - 40" Mower | 2690762 - Baron |
| 1695201 - 40" Mower | 2690772 - 2421 |
| 2690621 - Baron XL | |
| 2690622 - Baron XL | |
| 2690625 - 2420 XL | |

40" Mower Deck - Belt, Idle Arm & Hitch

REF NO	PART NO.	QTY.	DESCRIPTION
32	1666697SM	1	SPACER
30	1674671SM	1	SPRING, Extension
34	1719221SM	2	HUB, Pulley
35	1719842ASM	1	STOP, Belt
36	1719965SM	1	Grip, Black
25	1724626SM	1	BELT, Timing
31	1726387ASM	1	ARM, Idler
28	1731892SM	2	PULLEY, Idler
27	1923701SM	2	CAPSCREW, Hex Head, 3/8-16 x 2
33	1930601SM	1	CAPSCREW, Hex Head Taptite, 5/16-18 x 5/8
1	1720444SM	1	IDLER ARM ASSEMBLY, w/Bushings
1	1734495SM	1	IDLER ARM ASSEMBLY, w/Bushings
3	1715435SM	1	SPRING, Extension
4	1657242SM	1	SPACER
6	1960615SM	1	CARRIAGE BOLT, 3/8-16 x 2-1/2
7	1922755SM	3	WASHER
8	1960614SM	1	CAPSCREW, Hex Head, 3/8-16 x 3, G8
9	1933263SM	1	WASHER
10	2101096SM	1	PULLEY, 4-1/2 OD
11	1924940SM	6	WASHER
12	1732443SM	2	SPACER
13	1919439SM	1	NUT, Hex Lock ESNA, 3/8-16
14	1721425SM	1	WASHER & LOCK NUT ASSEMBLY, 3/8-16
15	1735714SM	1	V-BELT
16	1960519SM	1	NUT, Push
17	1720044ASM	1	HITCH, Mower
18	1715759SM	1	ROD
19	2156302SM	1	SPRING, Extension
20	2157081SM	2	SPACER
22	1928352SM	2	NUT, Hex Flange Lock, 3/8-16
21	2860681SM	2	NUT, Spiral Flange Toplock, 3/8-16
23	1921968SM	2	CAPSCREW, Hex Head, 3/8-16 1-3/8
24	1713578SM	1	ROD

Footnotes

The above parts group applies to the following Mfg. Nos.:

1695200 - 40" Mower 2690762 - Baron
1695201 - 40" Mower 2690772 - 2421
2690621 - Baron XL
2690622 - Baron XL
2690625 - 2420 XL

40" Mower Deck - Height Adjustment & Roller Bar

987502

NOTE: Unless noted otherwise,
use the standard hardware torque
specification chart.

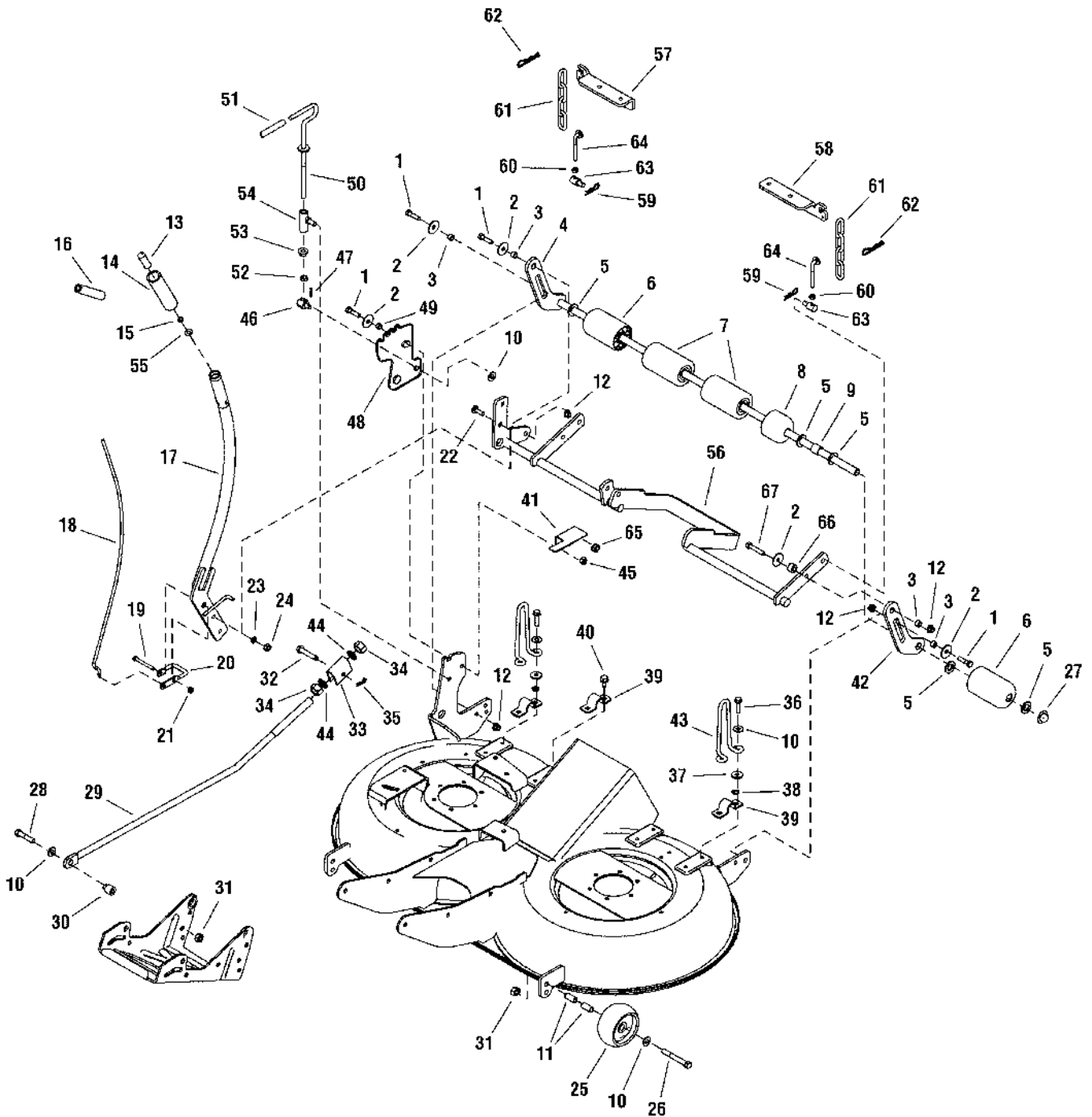

The above parts group applies to the following Mfg. Nos.:

- | | |
|---------------------|-----------------|
| 1695200 - 40" Mower | 2690762 - Baron |
| 1695201 - 40" Mower | 2690772 - 2421 |
| 2690621 - Baron XL | |
| 2690622 - Baron XL | |
| 2690625 - 2420 XL | |

40" Mower Deck - Height Adjustment & Roller Bar

REF NO	PART NO.	QTY.	DESCRIPTION
1	1921977SM	4	CAPSCREW, Hex Head, 5/16-18 x 1-1/4 G5
2	1960044SM	3	WASHER, 5/16
3	1960236SM	3	SPACER
4	1733081ASM	1	SHAFT & BAR ASSEMBLY, Roller
5	1924366SM	5	WASHER, 5/8
6	1722036SM	2	ROLLER, Round-End, 4.1
7	1668513SM	6	ROLLER, Flat-End, 4.1
8	1717675SM	1	ROLLER, Round-End, 2.05
9	1602946SM	1	SPACER
10	1924940SM	8	WASHER, Flat, 3/8
11	1960170SM	2	WASHER, Flat, 1/2
12	2860643SM	3	NUT, Hex Flange 5/16-18 Colar Lock
13	1723124SM	1	BUTTON, Red Nylon for 1/4 Rod
14	1713995SM	1	GRIP, Soft
15	1960674SM	1	NUT, Push Pal 1/4 Diameter Thread
16	1723321SM	1	SPRING, Compression
17	1732751ASM	1	HANDLE ASSEMBLY, Lift Curved
18	1732754SM	1	ROD, Curved, Latch
19	1921159SM	1	CAPSCREW, Hex Head 1/4-20 x 2-1/4 G5
20	1720599SM	1	LATCH
21	1920397SM	1	NUT, Hex Lock ESNA Light 1/4-20
22	1931335SM	2	BOLT, Carriage, 5/16-18 x 1 G5
23	1917356SM	2	LOCKWASHER, Spring 5/16
24	1917372SM	2	NUT, Hex 5/16-18
25	1714760SM	2	WHEEL
26	2108765SM	2	Bolt, Shoulder, 3/8-16 x 2.87
27	1960520SM	1	NUT, Push for 5/8 Diameter Stud Capped
28	1922606SM	1	CAPSCREW, Hex Head 3/8-16 x 1-3/4 G8
29	1722661SM	1	ROD, Pitch Adjust
30	1706644SM	1	SPACER, 3/8 x 3/4 x 15/16
31	2860681SM	1	NUT, Hex Toplock Spirallock Flange 3/8-16
32	2118053SM	1	PIN, Round Head Drilled 3/8 x 2
33	1706645ASM	1	TRUNNION, Pitch Adjust
34	1915726SM	2	NUT, Hex 5/8-11
35	1722460SM	1	PIN, Quick, Retaining
36	1931202SM	4	SCREW, Hex Washer Head Taptite 5/16-18 x 1-1/4
37	1919381SM	4	WASHER, 3/8
38	1933988SM	4	NUT, Push Pal 5/16 Diameter Thread
39	1665374SM	3	STRAP, Rocker Shaft
40	1664847SM	2	SCREW, Hex Washer Head Taptite 5/16-18 x 3/4
41	1720931ASM	1	BRACKET, Height of Cut
42	1734987SM	1	BAR, Roller
43	1719929SM	2	STOP, Up
44	1960703SM	2	WASHER, 5/8

Footnotes

The above parts group applies to the following Mfg. Nos.:

1695200 - 40" Mower 2690762 - Baron
 1695201 - 40" Mower 2690772 - 2421
 2690621 - Baron XL
 2690622 - Baron XL
 2690625 - 2420 XL

40" Mower Deck - Height Adjustment & Roller Bar

987502

NOTE: Unless noted otherwise,
use the standard hardware torque
specification chart.

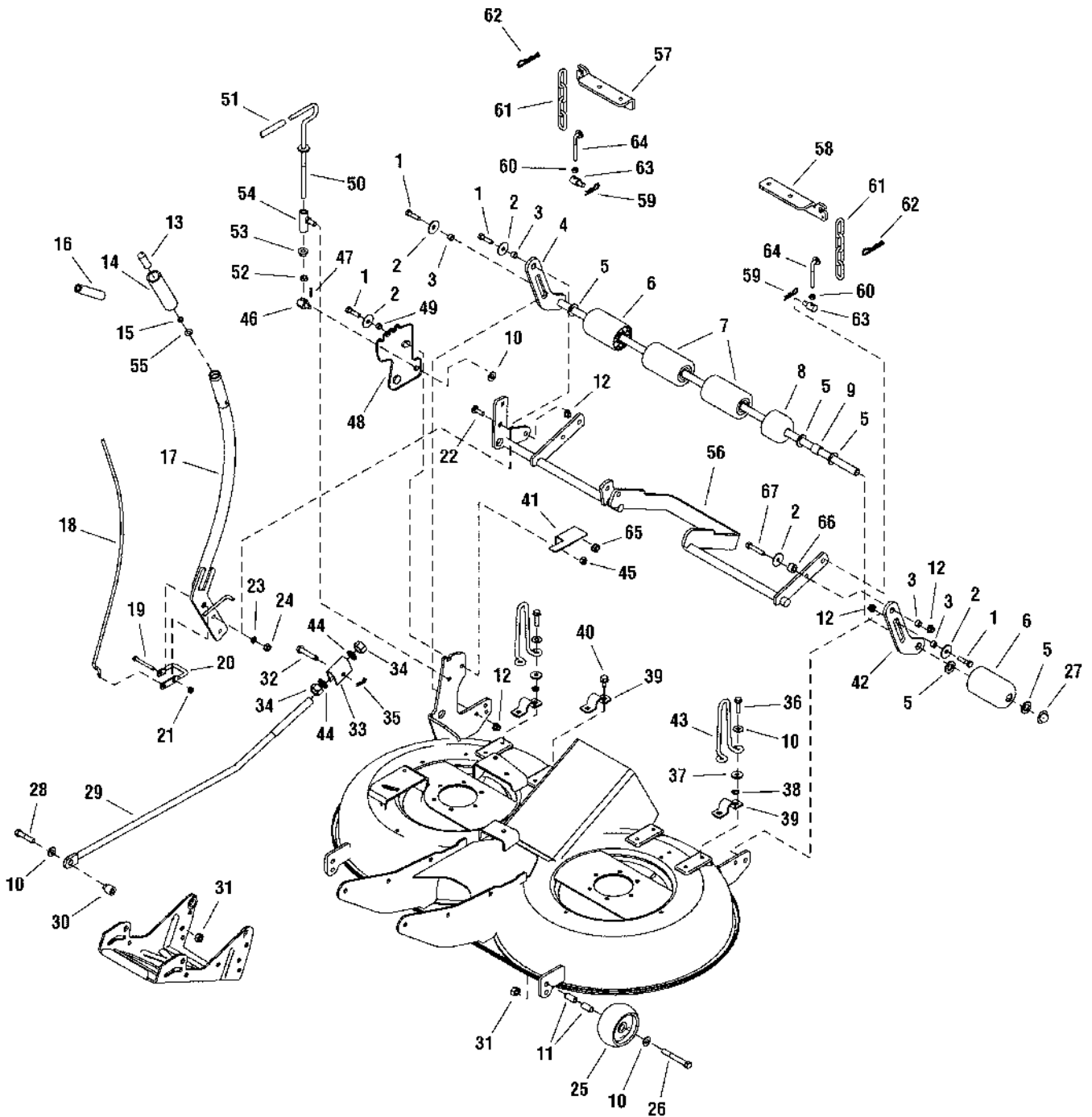

The above parts group applies to the following Mfg. Nos.:

- | | |
|---------------------|-----------------|
| 1695200 - 40" Mower | 2690762 - Baron |
| 1695201 - 40" Mower | 2690772 - 2421 |
| 2690621 - Baron XL | |
| 2690622 - Baron XL | |
| 2690625 - 2420 XL | |

40" Mower Deck - Height Adjustment & Roller Bar

REF NO	PART NO.	QTY.	DESCRIPTION
45	1919438SM	1	NUT, Hex Lock Esna Light 5/16-18
46	2108512SM	1	PIVOT, 3/4 Hex
47	1918447SM	1	PIN, Cotter, .75
48	1723409ASM	1	BRACKET, Adjusting
49	1666697SM	1	SPACER
50	1720704SM	1	ROD & WASHER ASSEMBLY
51	1651820SM	1	GRIP, Black Vinyl
52	1917421SM	1	NUT, Hex Jam 3/8-16
53	1960601SM	1	NUT, Hex Flange 3/8-16
54	2108241SM	1	GUIDE ASSEMBLY, Rod
55	1918265SM	1	WASHER, 5/16
56	1735095SM	1	SHAFT ASSEMBLY, Rocker
57	1727102ASM	1	HANGER, R.H.
58	1727103ASM	1	HANGER, L.H.
59	1960074SM	2	CLIP, Hair Pin
60	1920161SM	2	NUT, Hex Jam 5/16-18
61	1708088ASM	2	CHAIN, Link, 4 links
62	1960033SM	2	CLIP, Hair Pin
63	1731382SM	2	TRUNNION
64	1731384SM	2	ROD, Height Adjusting
65	1930645SM	1	NUT, Hex Flange 3/8-16 Two-Way Lock
66	1718762SM	1	SPACER, .70
67	1921972SM	1	CAPSCREW, Hex Head 5/16-18 x 2-1/2
69	1736359ASM	2	BAR, Extension
70	1923490SM	3	CAPSCREW, 3/8-16 x 1.0
71	1704082SM	1	NUT, Adjusting
72	1960687SM	6	NUT, Hex-Flange, 3/8-16, ESNA, BLK

Footnotes

The above parts group applies to the following Mfg. Nos.:

1695200 - 40" Mower 2690762 - Baron
1695201 - 40" Mower 2690772 - 2421
2690621 - Baron XL
2690622 - Baron XL
2690625 - 2420 XL

40" Mower Deck - Housing, Arbors & Blade

987503

NOTE: Unless noted otherwise,
use the standard hardware torque
specification chart.

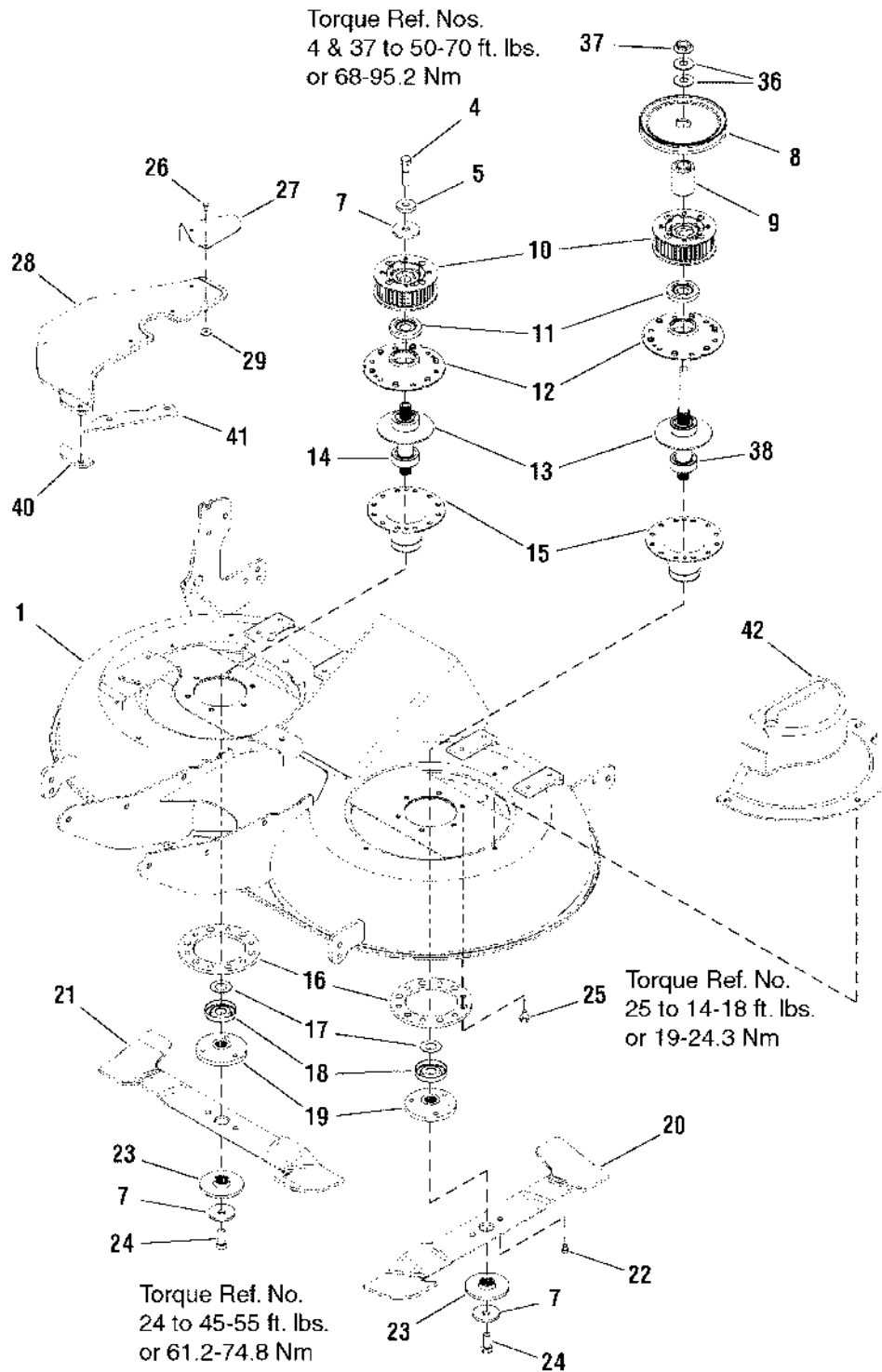

The above parts group applies to the following Mfg. Nos.:

- 1695200 - 40" Mower
- 1695201 - 40" Mower
- 2690621 - Baron XL
- 2690622 - Baron XL
- 2690625 - 2420 XL

40" Mower Deck - Housing, Arbors & Blade

REF NO	PART NO.	QTY.	DESCRIPTION
1	1687321SM	1	HOUSING ASSEMBLY, 40" Orange
1	1687321SM	1	HOUSING ASSEMBLY, 40" Orange
1	1687322SM	1	HOUSING ASSEMBLY, 40" Red
1	1687322SM	1	HOUSING ASSEMBLY, 40" Red
3	1664847SM	6	SCREW, Hex Washer Head Taptite 5/16-18 x 3/4
3	1664847SM	6	SCREW, Hex Washer Head Taptite 5/16-18 x 3/4
4	2830584SM	1	CAPSCREW, Hex Head 7/16-14 x 2-3/4 G8
4	2830584SM	1	CAPSCREW, Hex Head 7/16-14 x 2-3/4 G8
5	1933263SM	1	WASHER, 7/16
5	1933263SM	1	WASHER, 7/16
7	1656916SM	3	WASHER, Spring
7	1656916SM	3	WASHER, Spring
8	1732123SM	1	PULLEY
8	1732123SM	1	PULLEY
9	1719862SM	1	HUB
9	1719862SM	1	HUB
10	1732590SM	2	SPROCKET & FLANGE ASSEMBLY, Rivets/Screws 40"
10	1732590SM	2	SPROCKET & FLANGE ASSEMBLY, Rivets/Screws 40"
11	1657969SM	2	SHIELD, Bearing, Mower Arbor Upper Heat Treated
11	1657969SM	2	SHIELD, Bearing, Mower Arbor Upper Heat Treated
12	1655729ASM	2	HOUSING, Arbor Top
12	1655729ASM	2	HOUSING, Arbor Top
13	1707335SM	2	GASKET, Foam
13	1707335SM	2	GASKET, Foam
14	1722396SM	1	ARBOR SHAFT & BEARINGS ASSEMBLY, 40"
14	1722396SM	1	ARBOR SHAFT & BEARINGS ASSEMBLY, 40"
15	1703273ASM	2	HOUSING & FITTING ASSEMBLY, Lower
15	1703273ASM	2	HOUSING & FITTING ASSEMBLY, Lower
16	1677274ASM	2	ADAPTER, Arbor
16	1677274ASM	2	ADAPTER, Arbor
17	1700230SM	2	WASHER, Shim
17	1700230SM	2	WASHER, Shim
18	1700229SM	2	SHIELD, Bearing
18	1700229SM	2	SHIELD, Bearing
19	1655777SM	2	ADAPTER, Blade
19	1655777SM	2	ADAPTER, Blade
20	1727477SM	1	BLADE, Mower L.H.
20	1727477SM	1	BLADE, Mower L.H.
21	1727478SM	1	BLADE, Mower R.H.
21	1727478SM	1	BLADE, Mower R.H.
22	1722258SM	2	PIN, Blade
22	1722258SM	2	PIN, Blade
23	1722257SM	2	WASHER, Spline
23	1722257SM	2	WASHER, Spline
24	2827120SM	2	CAPSCREW, Hex Head 7/16-14 x 2-1/4 G8

Footnotes

The above parts group applies to the following Mfg. Nos.:

1695200 - 40" Mower
 1695201 - 40" Mower
 2690621 - Baron XL
 2690622 - Baron XL
 2690625 - 2420 XL

40" Mower Deck - Housing, Arbors & Blade

987503

NOTE: Unless noted otherwise,
use the standard hardware torque
specification chart.

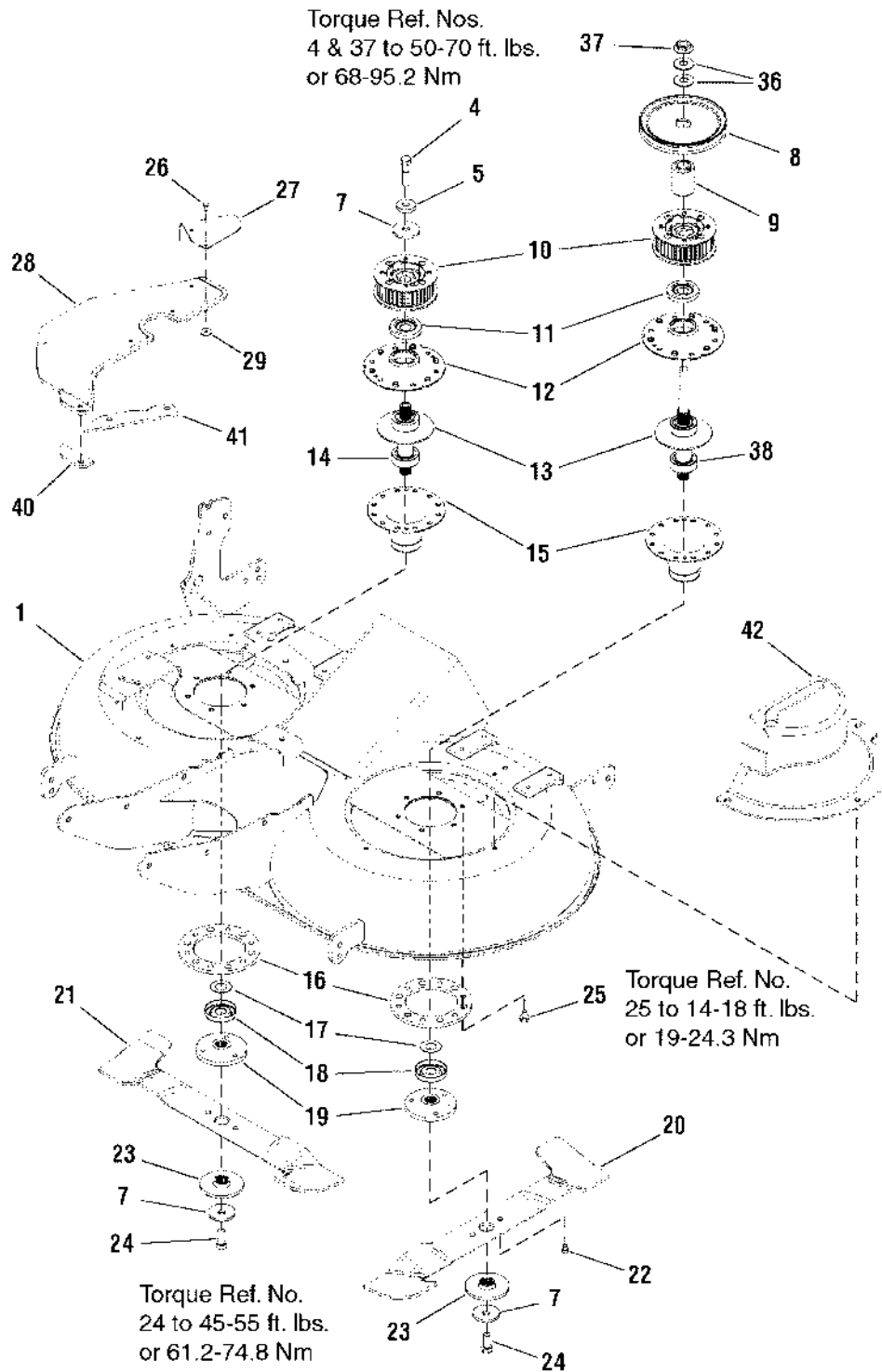

The above parts group applies to the following Mfg. Nos.:

- 2690762 - Baron
- 2690772 - 2421

40" Mower Deck - Housing, Arbors & Blade

REF NO	PART NO.	QTY.	DESCRIPTION
1	1687321SM	1	HOUSING ASSEMBLY, 40" Orange
1	1687321SM	1	HOUSING ASSEMBLY, 40" Orange
1	1687322SM	1	HOUSING ASSEMBLY, 40" Red
1	1687322SM	1	HOUSING ASSEMBLY, 40" Red
3	1664847SM	6	SCREW, Hex Washer Head Taptite 5/16-18 x 3/4
3	1664847SM	6	SCREW, Hex Washer Head Taptite 5/16-18 x 3/4
4	2830584SM	1	CAPSCREW, Hex Head 7/16-14 x 2-3/4 G8
4	2830584SM	1	CAPSCREW, Hex Head 7/16-14 x 2-3/4 G8
5	1933263SM	1	WASHER, 7/16
5	1933263SM	1	WASHER, 7/16
7	1656916SM	3	WASHER, Spring
7	1656916SM	3	WASHER, Spring
8	1732123SM	1	PULLEY
8	1732123SM	1	PULLEY
9	1719862SM	1	HUB
9	1719862SM	1	HUB
10	1732590SM	2	SPROCKET & FLANGE ASSEMBLY, Rivets/Screws 40"
10	1732590SM	2	SPROCKET & FLANGE ASSEMBLY, Rivets/Screws 40"
11	1657969SM	2	SHIELD, Bearing, Mower Arbor Upoer Heat Treated
11	1657969SM	2	SHIELD, Bearing, Mower Arbor Upoer Heat Treated
12	1655729ASM	2	HOUSING, Arbor Top
12	1655729ASM	2	HOUSING, Arbor Top
13	1707335SM	2	GASKET, Foam
13	1707335SM	2	GASKET, Foam
14	1722396SM	1	ARBOR SHAFT & BEARINGS ASSEMBLY, 40"
14	1722396SM	1	ARBOR SHAFT & BEARINGS ASSEMBLY, 40"
15	1703273ASM	2	HOUSING & FITTING ASSEMBLY, Lower
15	1703273ASM	2	HOUSING & FITTING ASSEMBLY, Lower
16	1677274ASM	2	ADAPTER, Arbor
16	1677274ASM	2	ADAPTER, Arbor
17	1700230SM	2	WASHER, Shim
17	1700230SM	2	WASHER, Shim
18	1700229SM	2	SHIELD, Bearing
18	1700229SM	2	SHIELD, Bearing
19	1655777SM	2	ADAPTER, Blade
19	1655777SM	2	ADAPTER, Blade
20	1727477SM	1	BLADE, Mower L.H.
20	1727477SM	1	BLADE, Mower L.H.
21	1727478SM	1	BLADE, Mower R.H.
21	1727478SM	1	BLADE, Mower R.H.
22	1722258SM	2	PIN, Blade
22	1722258SM	2	PIN, Blade
23	1722257SM	2	WASHER, Spline
23	1722257SM	2	WASHER, Spline
24	2827120SM	2	CAPSCREW, Hex Head 7/16-14 x 2-1/4 G8

Footnotes

The above parts group applies to the following Mfg. Nos.:

2690762 - Baron
2690772 - 2421

Not for
Reproduction

Not for
Reproduction

Not for
Reproduction

Hardware Identification & Torque Specifications

Torque Specification Chart								
FOR STANDARD METRIC MACHINE HARDWARE (Tolerance ± 20%)								
Property Class	5.6		8.8		10.9		12.9	
	Class 5.6		Class 8.8		Class 10.9		Class 12.9	
Size Of Hardware	in/lbs	Nm.	in/lbs	Nm.	in/lbs	Nm.	in/lbs	Nm.
	ft/lbs		ft/lbs		ft/lbs		ft/lbs	
M3	5.88	.56	13.44	1.28	19.2	1.80	22.92	2.15
M4	13.44	1.28	30.72	2.90	43.44	4.10	52.56	4.95
M5	26.4	2.50	60.96	5.75	5.97	8.10	7.15	9.7
M6	44.64	4.3	7.3	9.9	10.3	14	12.1	16.5
M7	5.2	7.1	12.1	16.5	16.9	23	19.9	27
M8	7.7	10.5	17.7	24	25	34	29	40
M10	15	21	35	48	50	67	59	81
M12	26	36	61	83	86.2	117	103	140
M14	42	58	101	132	136	185	162	220
M16	64	88	147	200	210	285	250	340
M18	89	121	202	275	287	390	346	470
M20	126	171	290	390	405	550	486	660
M22	169	230	390	530	559	745	656	890
M24	217	295	497	375	708	960	840	1140
M27	320	435	733	995	1032	1400	1239	1680
M30	435	590	995	1350	1401	1900	1681	2280
M33	590	800	1349	1830	1902	2580	2278	3090
M36	759	1030	1740	2360	2441	3310	2935	3980
M39	988	1340	2249	3050	3163	4290	3798	5150

Torque Specification Chart						
FOR STANDARD MACHINE HARDWARE (Tolerance ± 20%)						
Hardware Grade	No Marks		SAE Grade 5		SAE Grade 8	
	SAE Grade 2		SAE Grade 5		SAE Grade 8	
Size Of Hardware	in/lbs	Nm.	in/lbs	Nm.	in/lbs	Nm.
	ft/lbs		ft/lbs		ft/lbs	
8-32	19	2.1	30	3.4	41	4.6
8-36	20	2.3	31	3.5	43	4.9
10-24	27	3.1	43	4.9	60	6.8
10-32	31	3.5	49	5.5	68	7.7
1/4-20	66	7.6	8	10.9	12	16.3
1/4-28	76	8.6	10	13.6	14	19.0
5/16-18	11	15.0	17	23.1	25	34.0
5/16-24	12	16.3	19	25.8	29	34.0
3/8-16	20	27.2	30	40.8	45	61.2
3/8-24	23	31.3	35	47.6	50	68.0
7/16-14	30	40.8	50	68.0	70	95.2
7/16-20	35	47.6	55	74.8	80	108.8
1/2-13	50	68.0	75	102.0	110	149.6
1/2-20	55	74.8	90	122.4	120	163.2
9/16-12	65	88.4	110	149.6	150	204.0
9/16-18	75	102.0	120	163.2	170	231.2
5/8-11	90	122.4	150	204.0	220	299.2
5/8-18	100	136	180	244.8	240	326.4
3/4-10	160	217.6	260	353.6	386	525.0
3/4-16	180	244.8	300	408.0	420	571.2
7/8-9	140	190.4	400	544.0	600	816.0
7/8-14	155	210.8	440	598.4	660	897.6
1-8	220	299.2	580	788.8	900	1,244.0
1-12	240	326.4	640	870.4	1,000	1,360.0

The guides and ruler furnished below are designed to help you select the appropriate hardware.



Nut, M8

Thread Diameter (mm)
Inside Diameter (in)
Threads per inch

Nut, 1/2-16

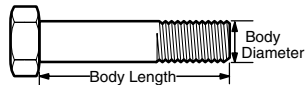

Screw, M8- 1.25 x 25

Thread Diameter (mm)
Body Diameter
Distance between threads (mm)
Threads per inch
Body Length (mm)
Body Length (in)

Screw, 1/2- 16 x 2

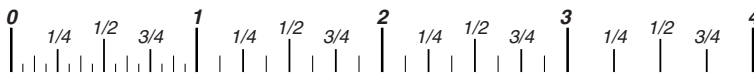

Standard Hardware Sizing

When a washer or nut is identified as **1/2"** (M8), this is the *Nominal size*, meaning the *inside diameter* is 1/2 inch (8mm metric thread diameter); if a second number is present it represents the *threads per inch* (distance between threads).

When bolt or capscrew is identified as **1/2 - 16 x 2"** (M8 - 1.25 x 50), this means the *Nominal size*, or body diameter is 1/2 inch (8mm metric thread diameter), the second number, 16, represents the *threads per inch*, (1.25 thread diameter). The final number is the body length of the bolt or screw, 2 inches (50mm).

NOTES

- These torque values are to be used for all hardware excluding: locknuts, self-tapping screws, thread forming screws, sheet metal screws and socket head setscrews.
- Recommended seating torque values for locknuts:
 - for prevailing torque locknuts - use 65% of grade 5 torques.
 - for flange whizlock nuts and screws - use 135% of grade 5 torques.
- Unless otherwise noted on assembly drawings, all torque values must meet this specification.

Common Hardware Types

Hex Head Capscrew

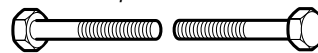

Washer



Lockwasher

Carriage Bolt



Hex Nut

Wrench & Fastener Size Guide

1/4" Bolt or Nut Wrench—7/16"	5/16" Bolt or Nut Wrench—1/2"	3/8" Bolt or Nut Wrench—9/16"	7/16" Bolt or Nut Wrench (Bolt)—5/8" Wrench (Nut)—11/16"	1/2" Bolt or Nut Wrench—3/4"
M6 Bolt or Nut Wrench—10mm	M8 Bolt or Nut Wrench—13mm	M10 Bolt or Nut Wrench—17mm	M12 Bolt or Nut Wrench—19mm	M14 Bolt or Nut Wrench—22mm

Not for
Reproduction

**IT IS THE POLICY OF BRIGGS & STRATTON CORP. TO IMPROVE ITS PRODUCTS
WHENEVER IT IS POSSIBLE AND PRACTICAL TO DO SO. WE RESERVE THE RIGHT TO
MAKE CHANGES OR ADD IMPROVEMENTS AT ANY TIME WITHOUT INCURRING ANY
OBLIGATION TO MAKE SUCH CHANGES ON PRODUCTS.**

Briggs & Stratton Yard Power Products Group

3515 N. 124 Street / PO Box 702
Wauwatosa, WI 53222 USA

www.simplicitymfg.com

© Copyright 2010 by Briggs & Stratton Corporation
Milwaukee, WI, USA. All rights reserved