

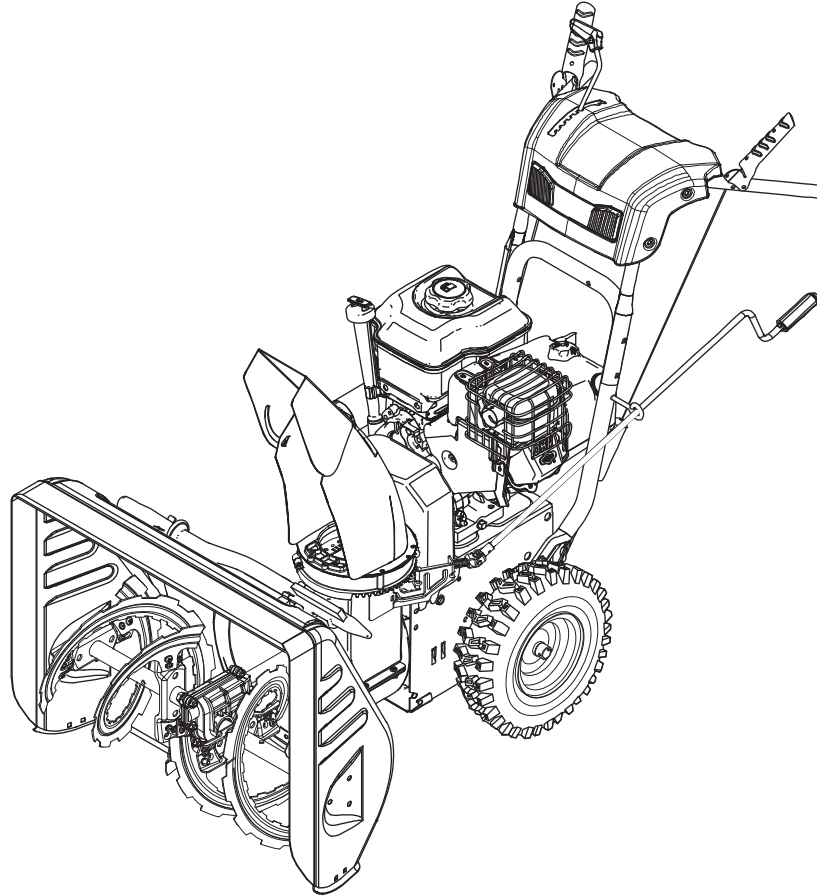

Parts Manual



24" Dual Stage Snowthrowers

Models

Mfg. No.	Description
1696154-00	824LD, 8TP 24" Dual Stage Snowthrower (2012)
1696253-00	BL924R, 9TP 24" Dual Stage Snowthrower (CE) (2012)

Manual Part No. 1755483

Revision -

Rev. Date: 6/20/2012

Not for
Reproduction

PRODUCT COMPONENTS	PAGES
Handles & Controls Group	4
Engine & Frame Group	8
Auger Housing Group	12
Auger Drive Group	14
Traction Drive Group	16
Wheels & Tires Group	18
Decals Group	20
Discharge Chute Group	22
Gear Case Assembly	24
Torque Specification Chart	Inside Back Cover

Not for
Reproduction

Handles & Controls Group

NOTE: Unless noted otherwise,
use the standard hardware torque
specification chart.

2990525

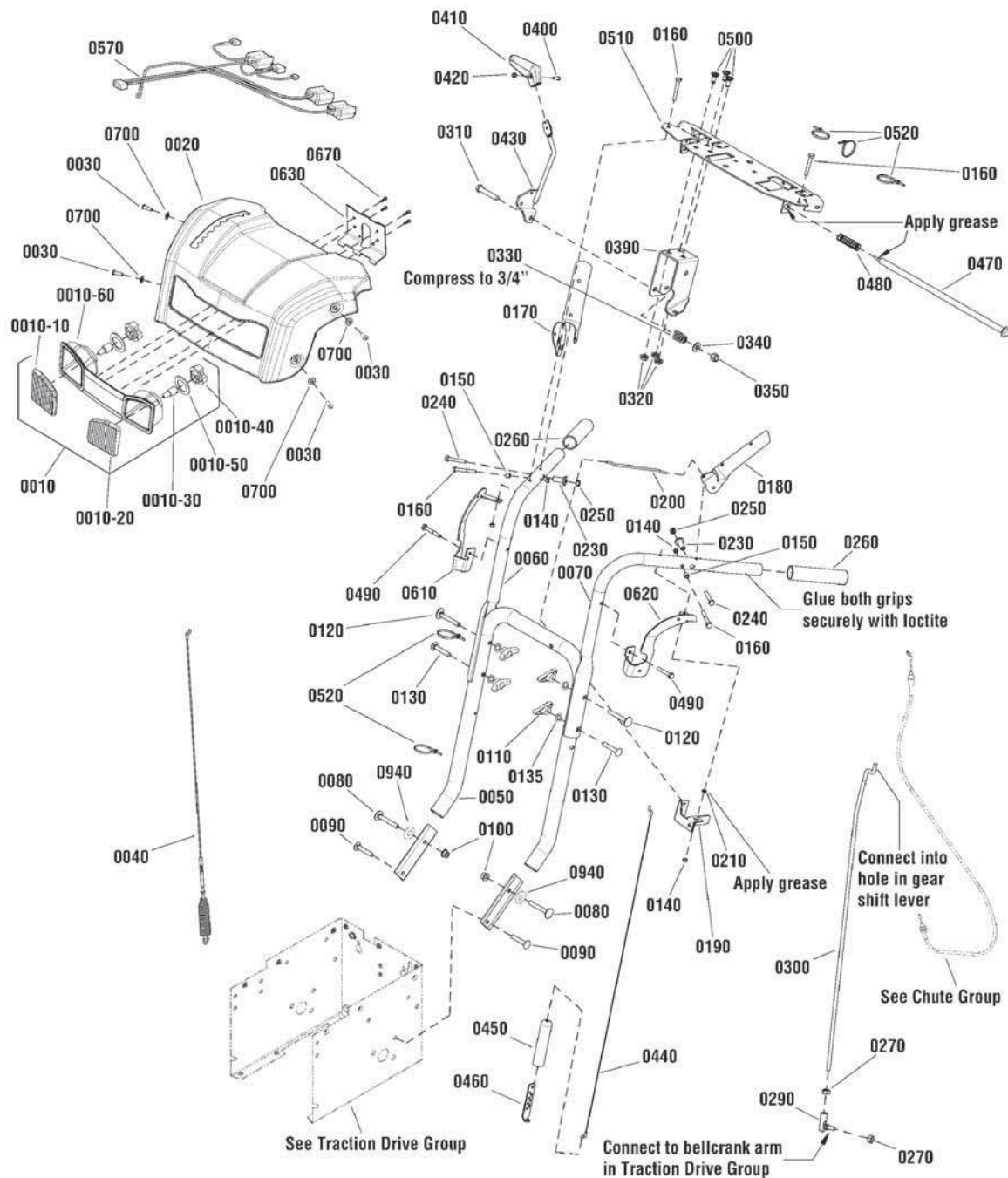

The above parts group applies to the following Mfg. Nos.:

1696154-00 - 824LD

1696253-00 - BL924R

Handles & Controls Group

REF NO	PART NO.	QTY.	DESCRIPTION
0010	1739686YP	1	LIGHT BAR ASSEMBLY
0010-10	-----	1	LENS, RH (Not a serviceable part, included with Ref. No. 0010)
0010-20	-----	1	LENS, LH (Not a serviceable part, included with Ref. No. 0010)
0010-30	1739689YP	2	LAMP, Halogen, 12V 20W
0010-40	1736180YP	2	SOCKET & GASKET ASSEMBLY, Headlight
0010-50	-----	2	GASKET, Single, Twin Light (Not a serviceable part, included with Ref. No. 0010-40)
0010-60	-----	1	BEZEL, Light, Panel (Not a serviceable part, included with Ref. No. 0010)
0020	1739345BSYP	1	COVER, Panel, Remote Deflector
0030	1960556SM	4	SCREW, Pan Head, Torx, 1/4-20 x 3/4, Taptite
0040	1732471SM	1	CABLE & SPRING ASSEMBLY, Auger Drive, RH
0050	1737274AYP	1	HANDLE, Lower
0060	1734587ASM	1	HANDLE, Upper, R.H.
0070	1734586ASM	1	HANDLE, Upper, L.H.
0080	1921333SM	2	CAPSCREW, Hex Head, 5/16-18 x 1, G5
0090	1664847SM	2	CAPSCREW, Hex Washer Head Taptite, 5/16-18 x 3/4
0100	1935048SM	2	NUT, Hex Flange Two Way Locking, 5/16-18
0110	7035744YP	2	WINGKNOB, 5/16-18
0120	1750299YP	2	BOLT, Carriage, Locking, 5/16-18 x 2-1/4
0130	7091189YP	2	BOLT, Carriage. 5/16-18 x 2, G2
0135	7090391SM	2	Washer, Locking, Internal Teeth, 5/16
0140	1920397SM	4	NUT, Hex Lock, 1/4-20
0150	1678392SM	2	SPACER, 17/64 ID x 3/8 OD x 11/32 Lg
0160	1921962SM	4	CAPSCREW, Hex Head, 1/4-20 x 1-3/4, G5
0170	1739783BMYP	1	LEVER, Clutch, RH
0180	1739782BMYP	1	LEVER, Clutch, LH
0190	1733505BMYP	1	BRKT, Pivot, Free Hand
0200	1736360YP	1	ROD, Hold Down, 5/32 Dia., 5-5/8 Lg
0210	1733095SM	1	SPACER, 1/4 ID
0230	1736542YP	2	SPACER, Stepped
0240	1750554YP	2	BOLT, Shoulder, Hex Washer Head, 1/4 x 1-9/32
0250	1933896SM	2	NUT, Nylock, 10-24
0260	1726317SM	2	HAND GRIP
0270	2820263SM	1	NUT, Hex, 5/16-24
0290	1739290YP	1	BALL JOINT, Quick Release
0300	1734354SM	1	ROD, 9/32 Dia. X 25-3/8 Lg
0310	1923701SM	2	CAPSCREW, Hex Head, 3/8-16 x 2, G5
0320	1931277SM	3	NUT, Hex Flange Whiz Lock, 5/16-18
0330	50786MA	2	SPRING, 1/2 Dia. x 3/4
0340	1918266SM	2	WASHER, 3/8 x 13/16 OD
0350	1919439SM	2	NUT, Hex Lock, 3/8-16
0390	1737684YP	1	BRACKET, Controls
0400	1960589SM	1	SCREW, Round Head Phillips, #10-24 x 3/4
0410	1733192SM	1	KNOB, Slot Speed

Footnotes

The above parts group applies to the following Mfg. Nos.:

1696154-00 - 824LD
1696253-00 - BL924R

Handles & Controls Group

NOTE: Unless noted otherwise,
use the standard hardware torque
specification chart.

2990525

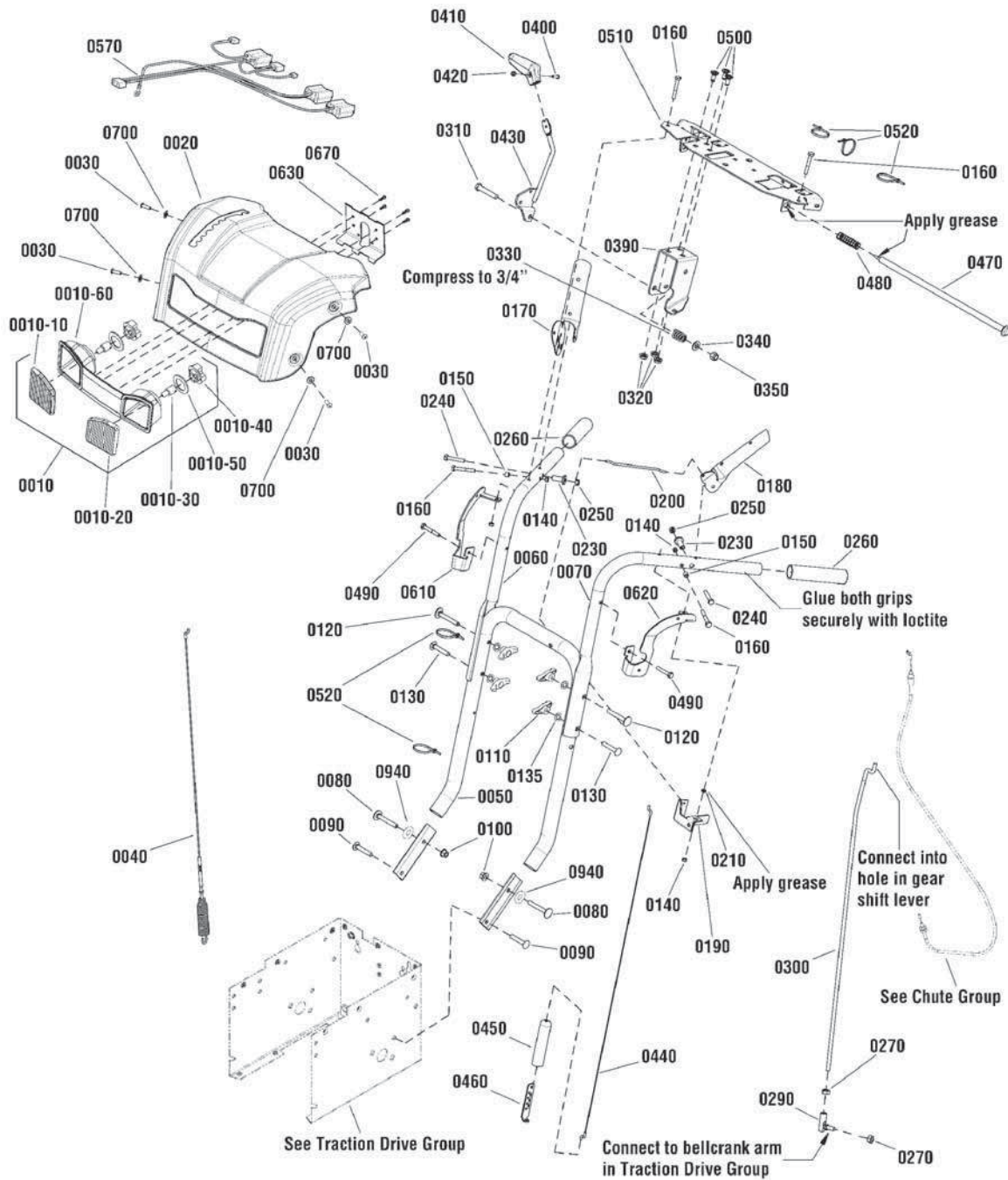

The above parts group applies to the following Mfg. Nos.:

1696154-00 - 824LD
1696253-00 - BL924R

Handles & Controls Group

REF NO	PART NO.	QTY.	DESCRIPTION
0420	1933896SM	1	NUT, Nylock, 10-24
0430	1736836YP	1	SPEED LEVER ASSEMBLY
0440	1501124MA	1	CABLE, Handle
0450	308146MA	1	BOOT, Spring End Cover, 4-1/16 Lg
0460	313441MA	1	BRACKET, Cable Adjusting
0470	1733509SM	1	ROD & SPRING ASSEMBLY
0480	2108360SM	1	SPRING, Compression, 017/32 ID x 2-1/4 Lg
0490	1927429SM	2	CAPSCREW, Hex Washer Head, Taptite, 1/4-20 x 5/8
0500	1931333SM	3	BOLT, Carriage, 5/16-18 x 3/4
0510	1739500BMYP	1	SUPPORT, Dash
0520	1701011SM	5	TIE, SELF LOCKING, 7-5/16 Lg
0570	1750359YP	1	HARNESS
0610	1739663BMYP	1	BRACKET, Mounting, Dash, R.H.
0620	1739664BMYP	1	BRACKET, Mounting, Dash, L.H.
0630	1739666BMYP	1	BRACKET, Light Mounting
0670	7091105YP	4	SCREW, Hex Washer Machine, #10-16 x 1/2
0700	1921319SM	4	WASHER, 1/4 x 5/8 OD
0940	71071MA	2	WASHER, 11/32 x 11/16 OD

Not for
Reproduction

Footnotes

The above parts group applies to the following Mfg. Nos.:

1696154-00 - 824LD
1696253-00 - BL924R

Engine & Frame Group

NOTE: Unless noted otherwise, use the standard hardware torque specification chart.

2990524

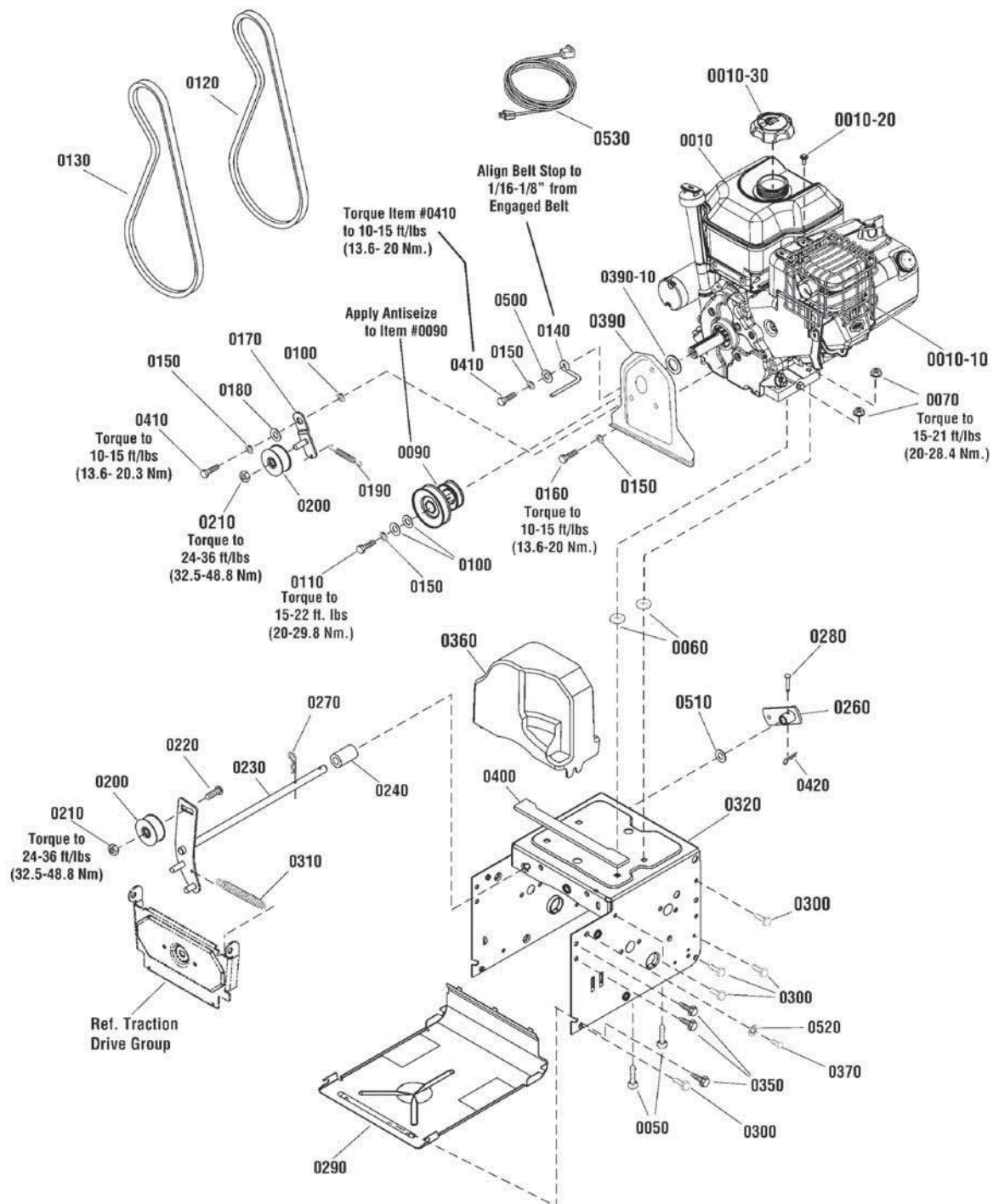

The above parts group applies to the following Mfg. Nos.:

- 1696154-00 - 824LD
- 1696253-00 - BL924R

Engine & Frame Group

REF NO	PART NO.	QTY.	DESCRIPTION
0010	12A107-0169-F8	1	* ENGINE, 8TP Briggs & Stratton, Domestic (Engine Model: 12A107-0169-F8)
0010	12D106-0168-F8	1	* ENGINE, 9TP Briggs & Stratton, Export (Engine Model: 12D106-0168-F8)
0010-10	797003	1	GUARD, Muffler, Plate (Domestic Models only)
0010-10	793193	1	GUARD, Muffler, Wire (Export Models Only)
0010-20	699854	2	SCREW, Muffler Guard
0010-30	795027	1	CAP, Fuel
0050	1931337SM	4	BOLT, Carriage, Short Neck, 5/16-18 x 1-1/2, G5
0060	028X76MA	4	NUT, Push, 1/4
0070	1739305YP	4	NUT, Hex Flange, ESNA, 5/16-18
0090	1501109MA	1	PULLEY, Engine
0100	1919381SM	3	WASHER, 5/16
0110	1921982SM	1	CAPSCREW, Hex Head, 5/16-24 x 1-1/4, G5
0120	1733324SM	1	V-BELT, Traction Drive, 3L 33.13
0130	1751417YP	1	BELT, Auger Drive, 4L 38.17
0140	1739070YP	1	GUIDE, Belt
0150	1917356SM	4	LOCKWASHER, Spring, 5/16
0160	1921515SM	1	CAPSCREW, Hex Head, 5/16-24 x 3/4, G5
0170	1501112YZMA	1	IDLER BRACKET
0180	1501065MA	1	BUSHING, Idler Bracket
0190	165X164MA	1	SPRING, Extension, Auger
0200	1502120MA	2	IDLER, Plastic Ball Bearing
0210	1960251SM	2	NUT, Hex Centerlock Jam, 3/8-16
0220	585781MA	1	BOLT, Carriage, Short Neck, 3/8-16 x 1-1/2, G5
0230	1752397YP	1	AUGER IDLER
0240	1501200MA	1	SPACER, 1/2 ID x 1 OD x 1-3/4"
0260	1733451SM	1	ARM, Control
0270	0031X6MA	1	PIN, Hair
0280	1736381YP	1	PIN, Clevis
0290	1740906ASM	1	PANEL, Bottom
0300	1927429SM	10	SCREW, Hex Washer Head, Taptite, 1/4-20 x 5/8
0310	165X159MA	1	SPRING, Extension, Auger
0320	1754891BSYP	1	FRAME
0350	1664847SM	6	SCREW, Hex Washer Head, Taptite, 5/16-18 x 3/4
0360	1753893YP	1	COVER, Belt
0370	1751355YP	2	SCREW, Hex Washer Head, Tap, SEMS, 1/4-20 x 3/4
0390	1733868BZYP	1	PLATE, Seal
0390-10	1733898SM	1	SEAL, Foam
0400	1750172YP	1	STRIP, Seal
0410	910828MA	2	BOLT, Hex, 5/16-24 x 1
0420	7023590SM	1	PIN, Cotter, Self Lock, 1/4
0500	7091528SM	1	WASHER, Flat, 3/8
0510	1960027SM	1	WASHER, 1/2
0520	7091890SM	2	WASHER, Internal Tooth, 1/4

Footnotes

Note* To verify your specific engine model, please reference the ID Tag located on your engine. See your local Briggs & Stratton distributor for parts and service.

The above parts group applies to the following Mfg. Nos.:

1696154-00 - 824LD
1696253-00 - BL924R

Engine & Frame Group

NOTE: Unless noted otherwise,
use the standard hardware torque
specification chart.

2990524

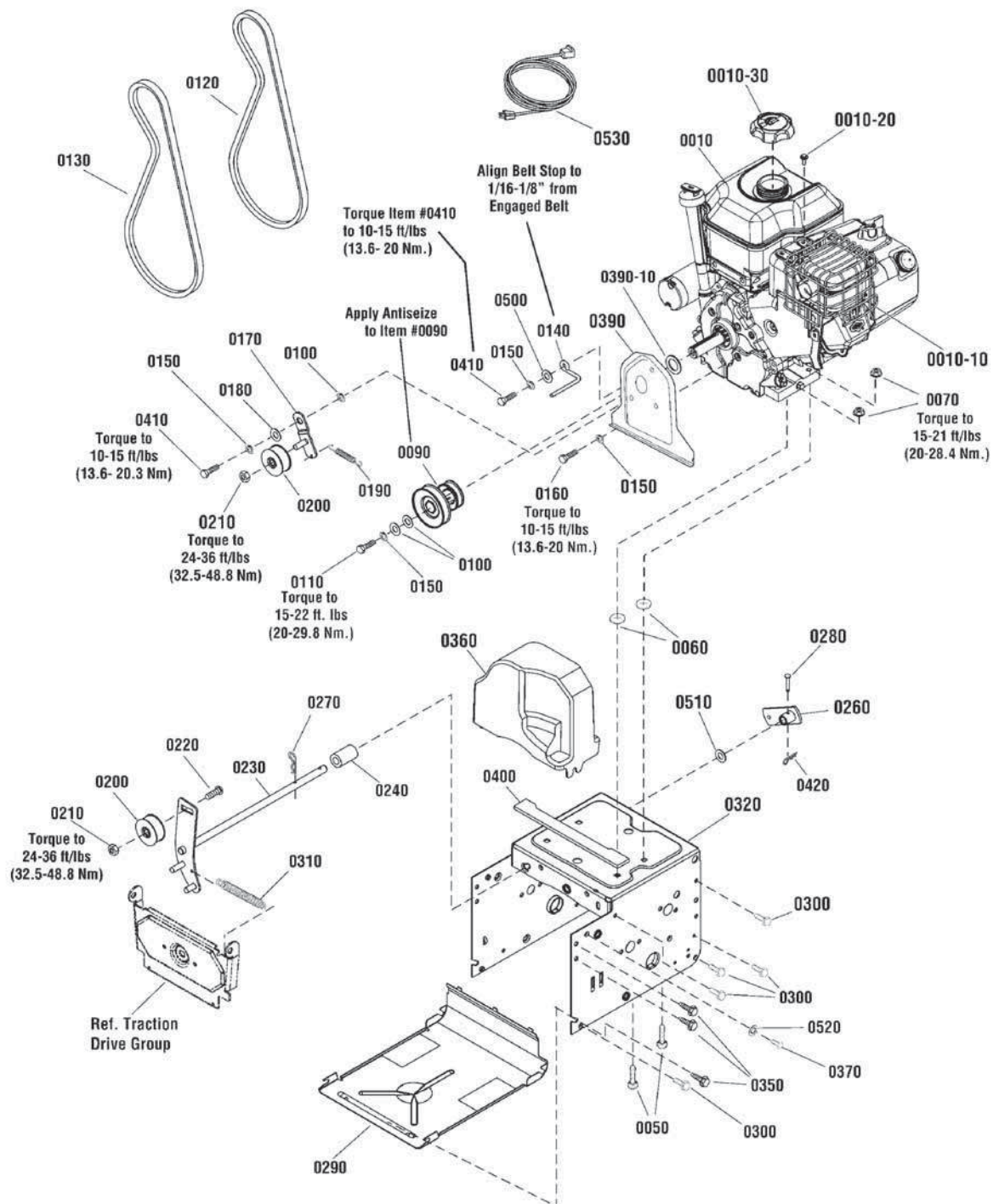

The above parts group applies to the following Mfg. Nos.:

1696154-00 - 824LD

1696253-00 - BL924R

Engine & Frame Group

REF NO	PART NO.	QTY.	DESCRIPTION
0530	6219MA	1	CORD, Electric, 110V (Domestic Models only)

Not for
Reproduction

Footnotes

Note* To verify your specific engine model, please reference the ID Tag located on your engine. See your local Briggs & Stratton distributor for parts and service.

The above parts group applies to the following Mfg. Nos.:

1696154-00 - 824LD
1696253-00 - BL924R

Auger Housing Group

NOTE: Unless noted otherwise,
use the standard hardware torque
specification chart.

2989847

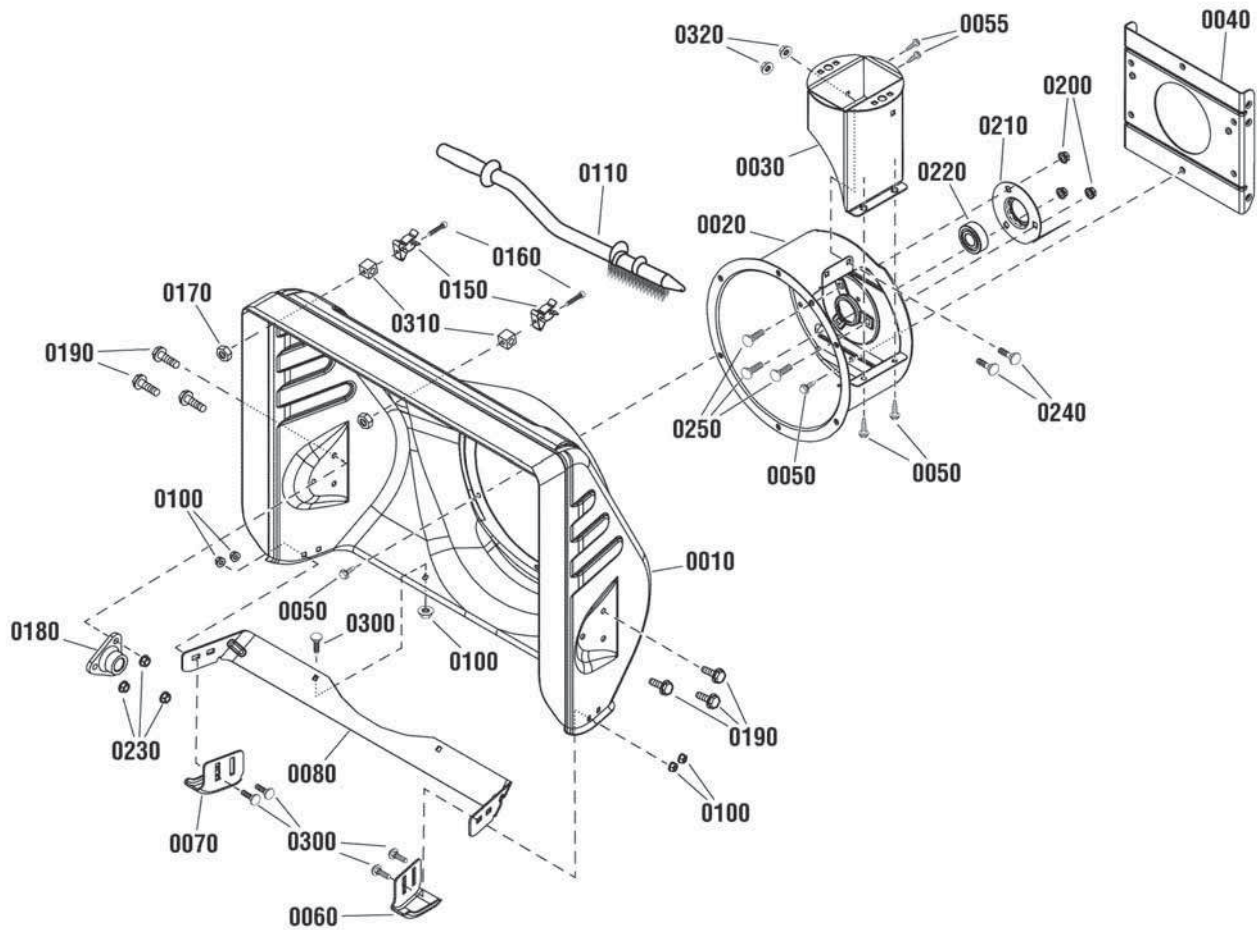

The above parts group applies to the following Mfg. Nos.:

1696154-00 - 824LD

1696253-00 - BL924R

Auger Housing Group

REF NO	PART NO.	QTY.	DESCRIPTION
0010	1687693YP	1	AUGER HOUSING, Stamped, VL
0020	1751278BSYP	1	HOUSING, IMPELLER, 10"
0030	1751938BSYP	1	CHIMNEY, Steel
0040	1751303BSYP	1	BRACKET, Rear Mounting
0050	1927428SM	14	SCREW, Hex Washer Head, Taptite, 1/4-20 x 3/8
0055	1750447YP	2	SCREW, Hex Washer Head, Taptite, 1/4-20 x 1/2
0060	1751407AYP	1	SKID SHOE, LH
0070	1751406AYP	1	SKID SHOE, RH
0080	1751418AYP	1	SCRAPER BAR
0100	5025391SM	6	NUT, Hex Nylock Flange, 1/4-20
0110	1736094YP	1	STICK, Cleanout Brush, 22-1/2
0150	1736620YP	2	CLAMP, Spring, Snow Brush
0160	06X115MA	2	SCREW, 10-24 x 1 1/4
0170	15X146MA	2	NUT, Nylock, 10 x 24
0180	9517MA	2	BEARING, Auger
0190	9357MA	6	CAPSCREW, Tapping, 5/16-18 x 3/4
0200	710026MA	3	NUT, Hex Flange, Serrated Lock, 5/16-18
0210	1665982SM	1	RETAINER, Bearing
0220	2108202SM	1	BEARING, Ball, 3/4 ID x 1-3/4 OD x 5/8"
0230	711862MA	6	NUT, Hex Flange, Top Lock, 5/16-18
0240	1931315SM	2	BOLT, Carriage, 1/4-20 x 1/2, G5
0250	7090001YP	3	BOLT, Carriage, Short Neck, 5/16-18 x 3/4
0300	1931315SM	6	BOLT, Carriage, 1/4-20 x 3/4 G5
0310	578063MA	2	BLOCK, Universal Pivot
0320	73826MA	2	NUT, Hex Center Lock, 1/4-20

Not for
Reproduction

Footnotes

The above parts group applies to the following Mfg. Nos.:

1696154-00 - 824LD
1696253-00 - BL924R

Auger Drive Group

NOTE: Unless noted otherwise,
use the standard hardware torque
specification chart.

2990523

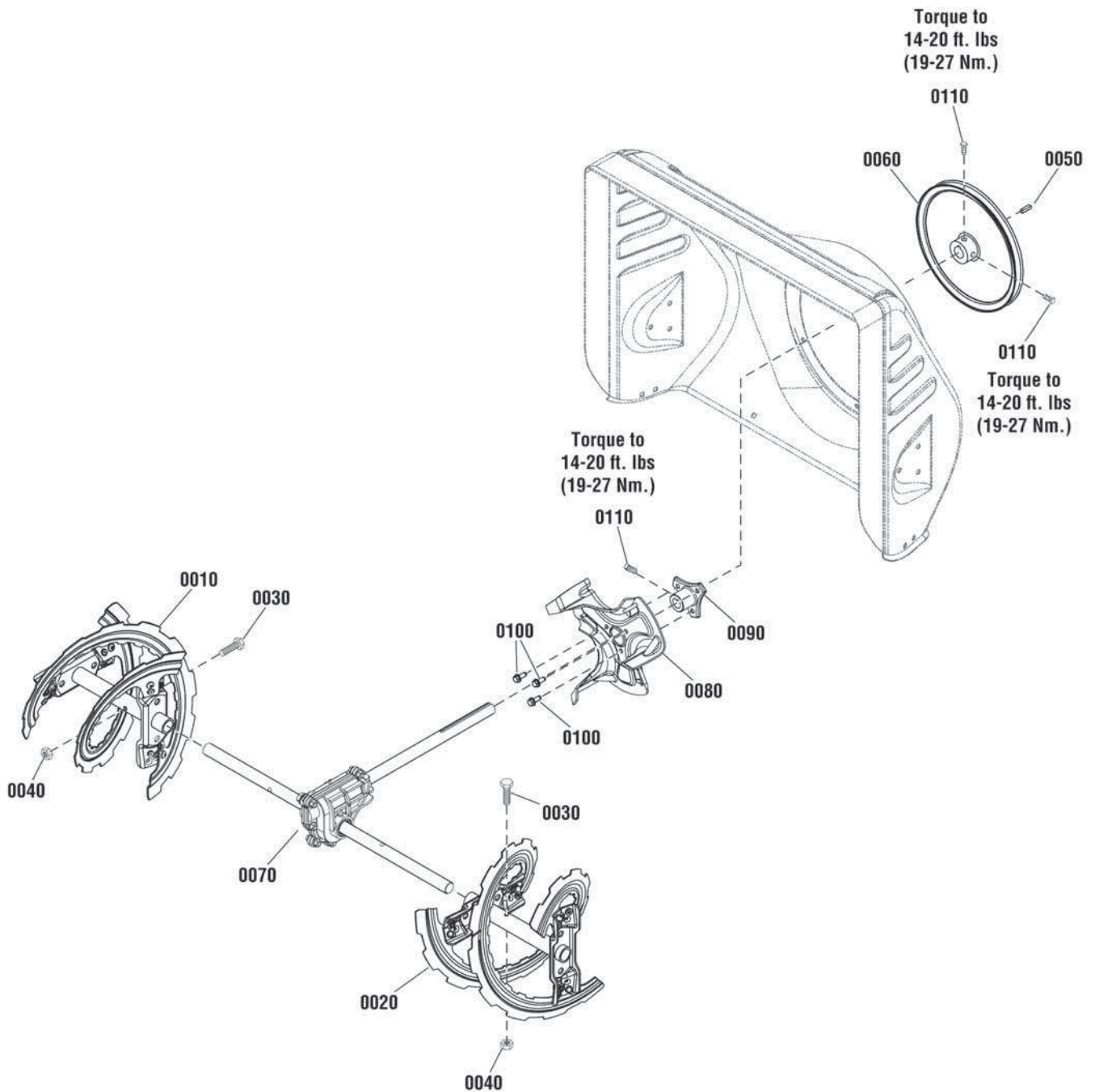

The above parts group applies to the following Mfg. Nos.:

1696154-00 - 824LD
1696253-00 - BL924R

Auger Drive Group

REF NO	PART NO.	QTY.	DESCRIPTION
0010	1752081BJYP	1	AUGER ASSEMBLY, RH
0020	1752067BJYP	1	AUGER ASSEMBLY, LH
0030	9524MA	2	CAPSCREW, Hex Head, 1/4-20 x 1-3/4, G2
0040	73826MA	2	NUT, Hex Centerlock, 1/4-20
0050	2001022MA	1	KEY, Square, 3/16 x 3/4
0060	1752220YP	1	AUGER PULLEY
0070	1753221YP	1	GEAR CASE ASSEMBLY
0080	1751348AYP	1	IMPELLER, 10"
0090	1739073YP	1	HUB, Impeller
0100	1924856SM	3	SCREW, Hex Washer Head Taptite, 5/16-18 x 1/2
0110	1930540SM	3	SET SCREW, Square Head, 5/16-18 x 5/8, G8

Not for
Reproduction

Footnotes

The above parts group applies to the following Mfg. Nos.:

1696154-00 - 824LD
1696253-00 - BL924R

Traction Drive Group

NOTE: Unless noted otherwise,
use the standard hardware torque
specification chart.

2990003

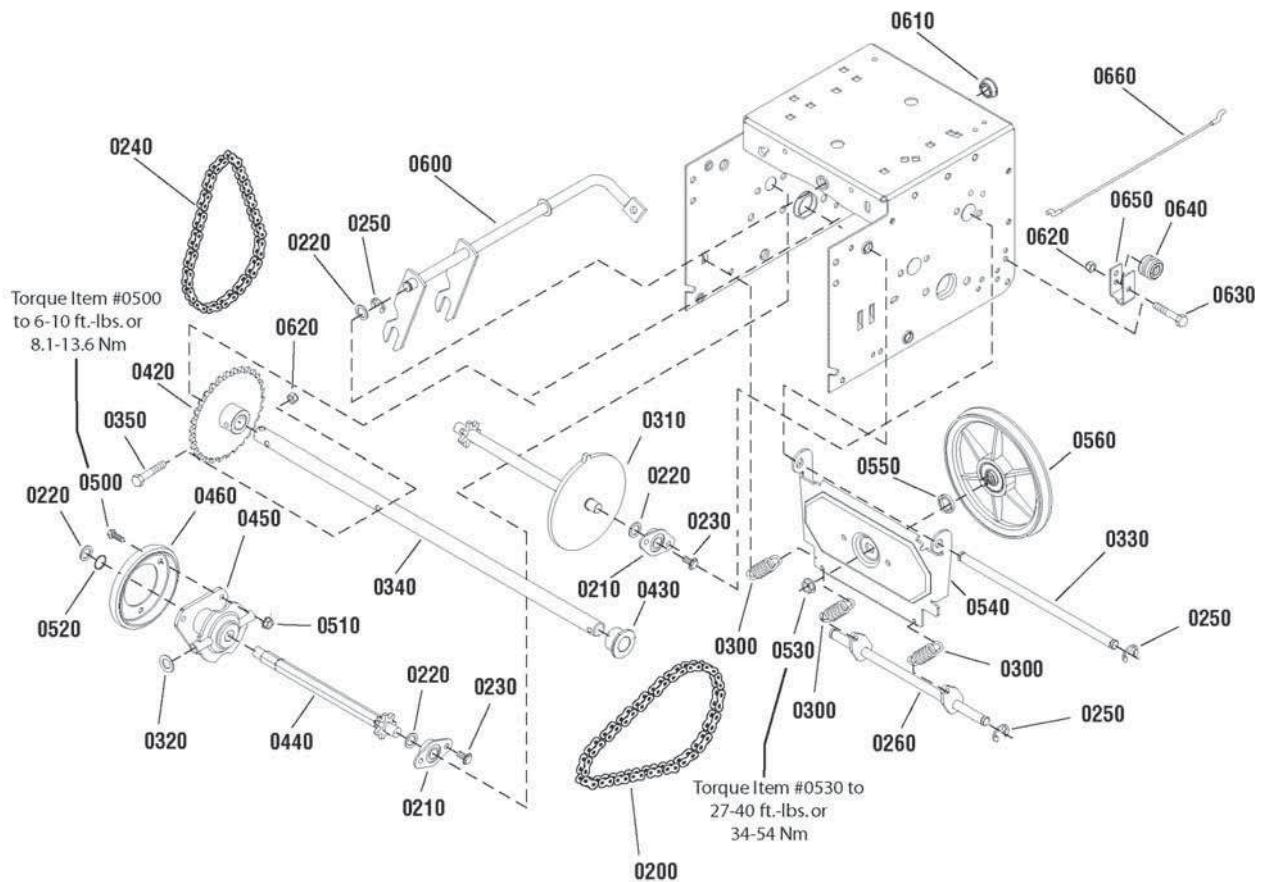

The above parts group applies to the following Mfg. Nos.:

1696154-00 - 824LD
1696253-00 - BL924R

Traction Drive Group

REF NO	PART NO.	QTY.	DESCRIPTION
0200	579851MA	1	CHAIN, Roller, 420 x 19"
0210	334163MA	4	RETAINER & BUSHING ASSEMBLY
0220	579858MA	5	WASHER, Flat, 1/2
0230	1924856SM	8	SCREW, Hex Washer Head, Taptite, 5/16-18 x 1/2
0240	579868MA	1	CHAIN, Roller, 420 x 18"
0250	11X30MA	5	RETAINER, Ring, 7/16
0260	1502105YZMA	1	SPRING LINK
0300	1736469YP	3	SPRING, Extension
0310	1501090MA	1	SPROCKET, Set
0320	1960027SM	2	WASHER, 1/2
0330	1501092YZMA	1	AXLE, Swing Plate, 10-1/2"
0340	1501562MA	1	AXLE, 21-3/8"
0350	01X193MA	1	BOLT, Hex Head, 1/4-20 x 1-3/4, G8
0420	1501089MA	1	AXLE SPROCKET, 30T
0430	1501114MA	2	BEARING, Axle, D-Hole
0440	1501236MA	1	SHAFT, Hex
0450	1739282YP	1	BEARING TRUNNION ASSEMBLY
0460	1501435MA	1	WHEEL, Friction
0500	1921959SM	3	CAPSCREW, Hex Head, 1/4-20 x 5/8, G5
0510	1928372SM	3	NUT, Hex KEPS, 1/4-20
0520	1733326SM	1	RING, Retaining, External Tooth, # 63
0530	15X114MA	1	NUT, Flange Lock, 3/8-24
0540	1501057YZMA	1	PLATE, Swinging
0550	1501158MA	1	SPACER, Friction Pulley
0560	1501115MA	1	FRICTION PULLEY ASSEMBLY
0600	1501110YZMA	1	SPEED SELECTOR
0610	579944MA	1	BEARING, Flange, 1/2 ID x 7/8OD
0620	1920397SM	2	NUT, Hex Lock, ESNA Light, 1/4-20
0630	1922837SM	1	CAPSCREW, Hex Head, 1/4-20 x 1-1/2, G5
0640	579860MA	1	SPOOL CABLE, Auger Control
0650	1501059YZMA	1	BRACKET, Cable Spool
0660	1501122MA	1	CABLE, Forward Drive, Lower

Footnotes

The above parts group applies to the following Mfg. Nos.:

1696154-00 - 824LD
1696253-00 - BL924R

Wheels & Tires Group

2989661

NOTE: Unless noted otherwise,
use the standard hardware torque
specification chart.

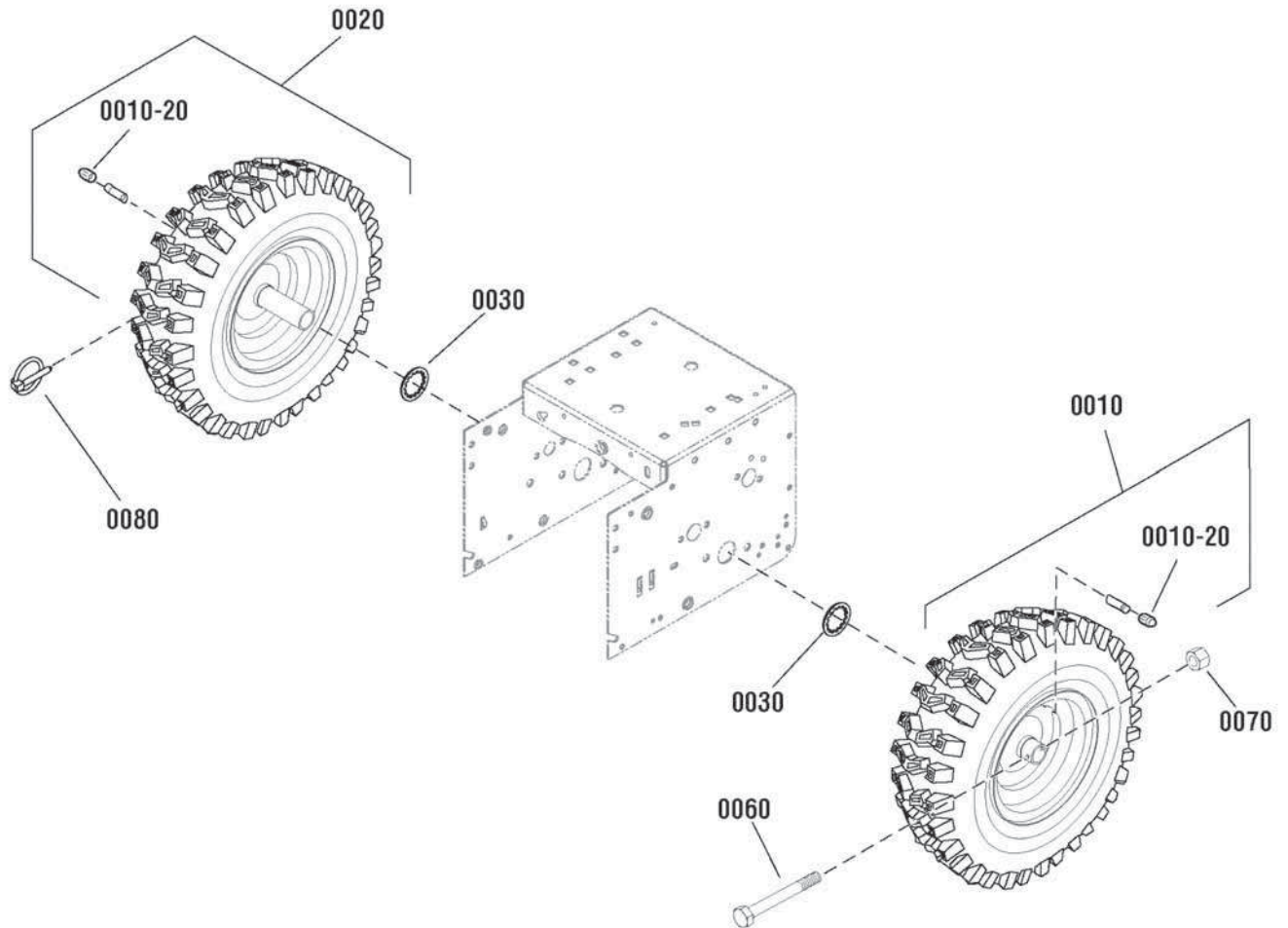

The above parts group applies to the following Mfg. Nos.:

1696154-00 - 824LD
1696253-00 - BL924R

Wheels & Tires Group

REF NO	PART NO.	QTY.	DESCRIPTION
0010	1754328YP	1	WHEEL & TIRE ASSEMBLY, 13 x 5, P2-407, LH
0020	1754329YP	1	WHEEL & TIRE ASSEMBLY, 13 x 5, P2-407, RH
0010-20	2172353SM	1	VALVE STEM & CAP
0030	1657528SM	2	RING, Retaining, Self Lock, 3/4
0060	577015MA	1	BOLT, Hex, 1/4-20 x 1-3/4, G5
0070	15X145MA	1	NUT, Hex, Nylock, 1/4-20
0080	73842MA	1	PIN, Klik, 1/4 x 1-3/8

Not for
Reproduction

Footnotes

The above parts group applies to the following Mfg. Nos.:

1696154-00 - 824LD
1696253-00 - BL924R

Decals Group

NOTE: Unless noted otherwise, use the standard hardware torque specification chart.

2990526

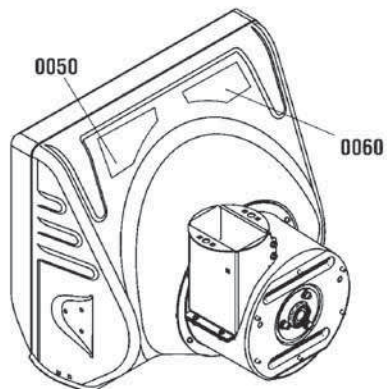
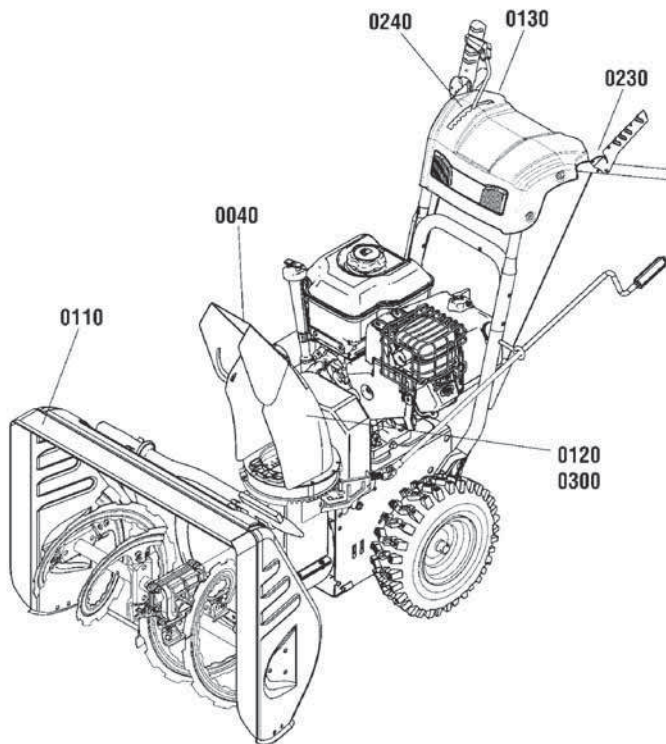

0040

Amputation hazard
 Contact with moving parts or a
 chain will cause serious injury.
 • Shut off engine before unclogging
 discharge chute.
 • Use clean-cut tool, not hands!

Risque d'amputation
 Tout contact avec des pièces en mouvement à l'intérieur
 de la gazolette provoquera de graves blessures.
 • Arrêter le moteur avant de dégager la gazolette
 d'éjection.
 • Utiliser l'outil à décharge, pas les mains!

WARNING

Shut off engine and remove key before performing maintenance or repair work.

Read the operator's manual for operating and safety instructions.

AVERTISSEMENT

Arrêter le moteur et retirer la clé avant d'effectuer tout entretien ou toute réparation.

Lire les consignes de sécurité et d'utilisation dans le manuel d'utilisation.

0050

Risque d'amputation

• Tout contact avec la tarière provoquera de graves blessures.
 • Tenir vos pieds, vos mains et vêtements à distance.
 • Tenir les spectateurs à distance.

Amputation Hazard

• Contact with auger will cause serious injury.
 • Keep hands, feet and clothing away.
 • Keep bystanders away.

Danger objets projetés

• Ne jamais diriger la chute en direction des personnes ou biens matériels.

Thrown Objects Hazard

• Never direct discharge chute towards persons or property.

0060

6

5

4

3

2

↑ 1

↓ R1

↓ R2

0240

0130

0230

The above parts group applies to the following Mfg. Nos.:

- 1696154-00 - 824LD
- 1696253-00 - BL924R

Decals Group

REF NO	PART NO.	QTY.	DESCRIPTION
0040	1727207SM	1	DECAL, Chute Warning, No Text (Export Models)
0040	1737865YP	1	DECAL, Chute Warning, FR/ENG (Domestic Models)
0050	1752919YP	1	DECAL, Warning, Safety
0060	1752422YP	1	DECAL, Danger, Safety, EN/FR
0110	1754717YP	1	DECAL, Housing, BL924R
0110	1755141YP	1	DECAL, Housing 824LD
0120	1750926YP	1	DECAL, Chute, Logo, LH
0130	1753133YP	1	DECAL, Auger Control
0230	1753134YP	1	DECAL, Traction Control
0240	1751582YP	1	DECAL, Gear Shift
0300	1754718YP	1	DECAL, Chute, Logo, RH

Not for
Reproduction

Footnotes

The above parts group applies to the following Mfg. Nos.:

1696154-00 - 824LD
1696253-00 - BL924R

Discharge Chute Group

NOTE: Unless noted otherwise,
use the standard hardware torque
specification chart.

2990050

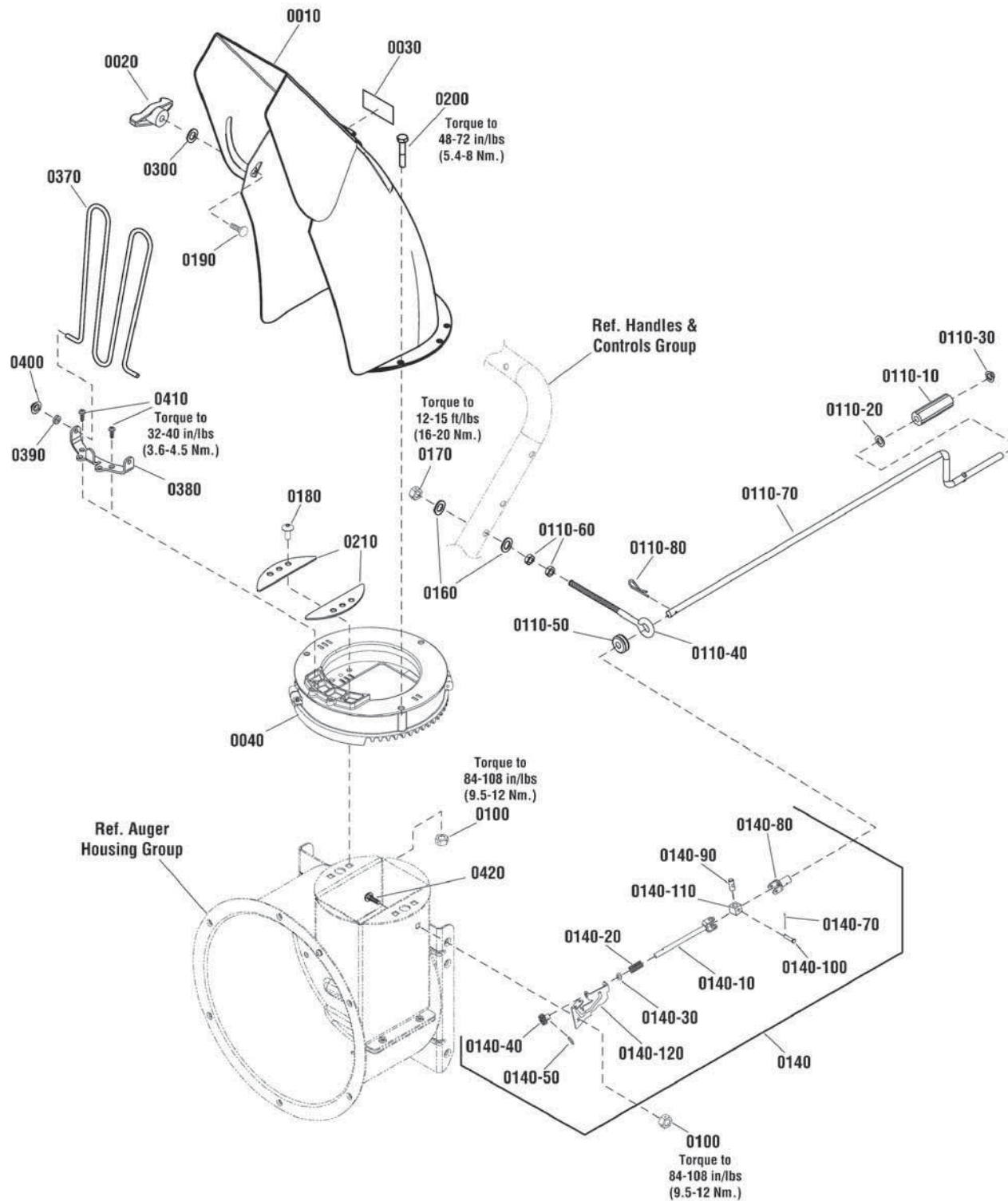

The above parts group applies to the following Mfg. Nos.:

1696154-00 - 824LD
1696253-00 - BL924R

Discharge Chute Group

REF NO	PART NO.	QTY.	DESCRIPTION
0010	1752977AYP	1	CHUTE
0020	7035744YP	1	KNOB, Wing, 5/16-18
0030	1733601SM	2	DECAL, Hinge
0040	1752395YP	1	CHUTE ROTATION ASSEMBLY, LH Crank
0100	1923358SM	5	NUT, Hex Centerlock, 1/4-20
0110-10	51443MA	1	KNOB, Sleeve
0110-20	309312MA	1	WASHER, Flat, 3/8
0110-30	73664MA	1	NUT, Push, 3/8
0110-40	1501456MA	1	EYEBOLT, 3/8-16 x 6-1/2"
0110-50	148MA	1	GROMMET, Eye Bolt
0110-60	71045MA	2	NUT, Hex Jam, 3/8-16
0110-70	1501074YZMA	1	CRANK, Chute Turn
0110-80	0031X6MA	1	PIN, Hair
0140	1752560YP	1	BRACKET ASSEMBLY, Chute Rotation (Includes Ref. Nos. 0140-10, 0140-20, 0140-30, 0140-40, 0140-50, 0140-60, 0140-70, 0140-80, 0140-90, 0140-100, 0140-110 & 0140-120)
0140-10	1501533YZMA	1	ROD, Yoke Crank
0140-20	164X37MA	1	SPRING, Compression
0140-30	017X48MA	1	WASHER, Flat, 3/8
0140-40	1501067MA	1	GEAR, 9 Tooth
0140-50	1501293MA	1	PIN, Hair
0140-70	579493MA	1	PIN, Cotter
0140-80	1501075YZMA	1	YOKE TUBE ASSEMBLY, Adapter
0140-90	578060MA	1	PIN, Universal Joint
0140-100	578309MA	1	PIN, Clevis, 1/4
0140-110	578063MA	1	BLOCK, Universal Pivot
0140-120	----	1	BRACKET, Mounting, Chute Rotation Gear (Not a serviceable part. Order Ref. No. 0140)
0160	71072MA	2	WASHER, Flat, 3/8
0170	71046MA	1	NUT, Hex, Nylock, 3/8-16
0180	880456YP	4	SCREW, Torx Truss Head, 1/4-20 x 7/8
0190	1931337SM	1	BOLT, Carriage, Short Neck, 5/16-18 x 1-1/2
0200	880804YP	3	SCREW, Hi-Lo, 1/4 x 3/4
0210	1753477YP	2	STIFFENER, Chute Rotation
0300	2860210SM	1	WASHER, Nylon, 3/8
0370	1733475SM	1	GUARD, Chute
0380	1737683YP	1	BRACKET, Chute Guard
0390	1738174YP	2	GROMMET, Chute Guard Bracket
0400	1960140SM	2	NUT, Push, 3/16
0410	880070YP	4	SCREW, 310, Hi-Lo x 1/2
0420	1931315SM	1	BOLT, Carriage, Short Neck, 1/4-20 x 1/2, G5

Footnotes

The above parts group applies to the following Mfg. Nos.:

1696154-00 - 824LD
1696253-00 - BL924R

Gear Case Assembly

NOTE: Unless noted otherwise,
use the standard hardware torque
specification chart.

1753221

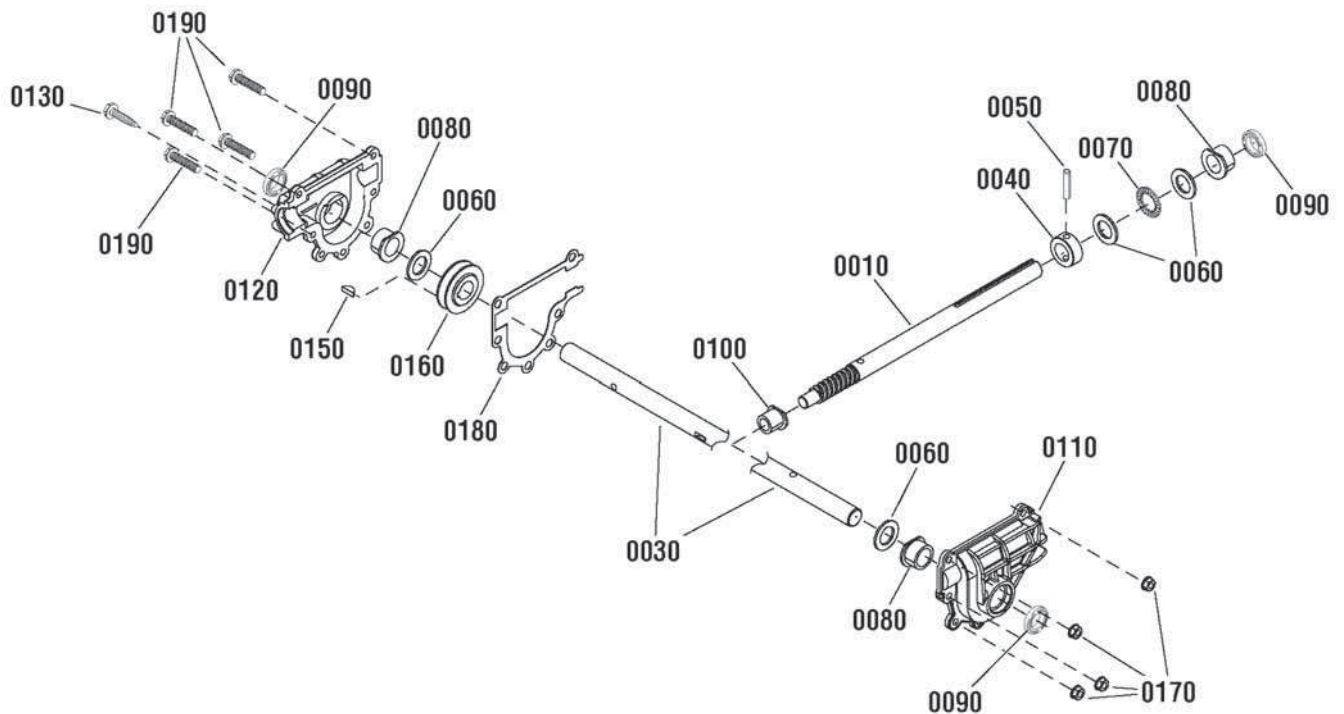

The above parts group applies to the following Mfg. Nos.:

1696154-00 - 824LD

1696253-00 - BL924R

Gear Case Assembly

REF NO	PART NO.	QTY.	DESCRIPTION
0010	1751402YP	1	SHAFT, Impeller
0030	1751419YP	1	SHAFT, Auger
0040	580295MA	1	COLLAR, Thrust, 3/4 x 1-1/4
0050	454565MA	1	PIN, Spring, 1/4 x 1-1/4
0060	48275MA	4	WASHER, Thrust
0070	50684MA	1	BEARING, Roll Thrust, 3/4 ID x 1-1/4 OD
0080	50304MA	3	BEARING, Flange, 3/4 ID x 1 OD
0090	9566MA	3	SEAL, Oil
0100	50221MA	1	BEARING, Flange, 1/2 ID x 3/4 OD
0110	10576MA	1	CASE, Gear, LH
0120	10577MA	1	CASE, Gear, RH
0130	9344MA	1	SCREW, Hex Washer Head, Tap, 3/8-16 x 1/2
0150	431787MA	1	KEY, Woodruff
0160	1752499YP	1	GEAR, Worm
0170	15X143MA	7	NUT, Flange Lock, 1/4-20
0180	51279MA	1	GASKET
0190	710025MA	7	CAPSCREW, 1/4-20 x 3/4, GR5

Not for
Reproduction

Footnotes

The above parts group applies to the following Mfg. Nos.:

1696154-00 - 824LD
1696253-00 - BL924R

Not for
Reproduction

Hardware Identification & Torque Specifications

Torque Specification Chart								
FOR STANDARD METRIC MACHINE HARDWARE (Tolerance ± 20%)								
Property Class	5.6		8.8		10.9		12.9	
	Class 5.6		Class 8.8		Class 10.9		Class 12.9	
Size Of Hardware	in/lbs		in/lbs		in/lbs		in/lbs	
	ft/lbs	Nm.	ft/lbs	Nm.	ft/lbs	Nm.	ft/lbs	Nm.
M3	5.88	.56	13.44	1.28	19.2	1.80	22.92	2.15
M4	13.44	1.28	30.72	2.90	43.44	4.10	52.56	4.95
M5	26.4	2.50	60.96	5.75	5.97	8.10	7.15	9.7
M6	44.64	4.3	7.3	9.9	10.3	14	12.1	16.5
M7	5.2	7.1	12.1	16.5	16.9	23	19.9	27
M8	7.7	10.5	17.7	24	25	34	29	40
M10	15	21	35	48	50	67	59	81
M12	26	36	61	83	86.2	117	103	140
M14	42	58	101	132	136	185	162	220
M16	64	88	147	200	210	285	250	340
M18	89	121	202	275	287	390	346	470
M20	126	171	290	390	405	550	486	660
M22	169	230	390	530	559	745	656	890
M24	217	295	497	375	708	960	840	1140
M27	320	435	733	995	1032	1400	1239	1680
M30	435	590	995	1350	1401	1900	1681	2280
M33	590	800	1349	1830	1902	2580	2278	3090
M36	759	1030	1740	2360	2441	3310	2935	3980
M39	988	1340	2249	3050	3163	4290	3798	5150

The guides and ruler furnished below are designed to help you select the appropriate hardware.



Nut, M8

Thread Diameter (mm)
Inside Diameter (in)
Threads per inch

Nut, 1/2-16

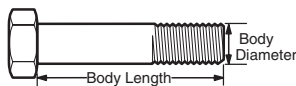

Screw, M8- 1.25 x 25

Thread Diameter (mm)
Body Diameter
Distance between threads (mm)
Threads per inch
Body Length (mm)
Body Length (in)

Screw, 1/2- 16 x 2

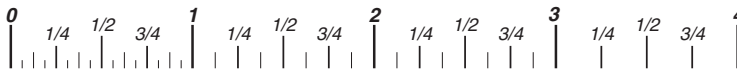

Standard Hardware Sizing

When a washer or nut is identified as **1/2"** (M8), this is the *Nominal size*, meaning the *inside diameter* is 1/2 inch (8mm metric thread diameter); if a second number is present it represents the *threads per inch* (distance between threads).

When bolt or capscrew is identified as **1/2 - 16 x 2"** (M8 - 1.25 x 50), this means the *Nominal size*, or body diameter is 1/2 inch (8mm metric thread diameter), the second number, 16, represents the *threads per inch*, (*1.25 thread diameter*). The final number is the body length of the bolt or screw, 2 inches (50mm).

Torque Specification Chart						
FOR STANDARD MACHINE HARDWARE (Tolerance ± 20%)						
Hardware Grade	No Marks		SAE Grade 5		SAE Grade 8	
	SAE Grade 2		SAE Grade 5		SAE Grade 8	
Size Of Hardware	in/lbs		in/lbs		in/lbs	
	ft/lbs	Nm.	ft/lbs	Nm.	ft/lbs	Nm.
8-32	19	2.1	30	3.4	41	4.6
8-36	20	2.3	31	3.5	43	4.9
10-24	27	3.1	43	4.9	60	6.8
10-32	31	3.5	49	5.5	68	7.7
1/4-20	66	7.6	8	10.9	12	16.3
1/4-28	76	8.6	10	13.6	14	19.0
5/16-18	11	15.0	17	23.1	25	34.0
5/16-24	12	16.3	19	25.8	29	34.0
3/8-16	20	27.2	30	40.8	45	61.2
3/8-24	23	31.3	35	47.6	50	68.0
7/16-14	30	40.8	50	68.0	70	95.2
7/16-20	35	47.6	55	74.8	80	108.8
1/2-13	50	68.0	75	102.0	110	149.6
1/2-20	55	74.8	90	122.4	120	163.2
9/16-12	65	88.4	110	149.6	150	204.0
9/16-18	75	102.0	120	163.2	170	231.2
5/8-11	90	122.4	150	204.0	220	299.2
5/8-18	100	136	180	244.8	240	326.4
3/4-10	160	217.6	260	353.6	386	525.0
3/4-16	180	244.8	300	408.0	420	571.2
7/8-9	140	190.4	400	544.0	600	816.0
7/8-14	155	210.8	440	598.4	660	897.6
1-8	220	299.2	580	788.8	900	1,244.0
1-12	240	326.4	640	870.4	1,000	1,360.0

NOTES

- These torque values are to be used for all hardware excluding: locknuts, self-tapping screws, thread forming screws, sheet metal screws and socket head setscrews.
- Recommended seating torque values for locknuts:
 - for prevailing torque locknuts - use 65% of grade 5 torques.
 - for flange whizlock nuts and screws - use 135% of grade 5 torques.
- Unless otherwise noted on assembly drawings, all torque values must meet this specification.

Common Hardware Types

Hex Head Capscrew



Washer



Lockwasher

Carriage Bolt



Hex Nut

Wrench & Fastener Size Guide

1/4" Bolt or Nut Wrench—7/16"	5/16" Bolt or Nut Wrench—1/2"	3/8" Bolt or Nut Wrench—9/16"	7/16" Bolt or Nut Wrench (Bolt)—5/8" Wrench (Nut)—11/16"	1/2" Bolt or Nut Wrench—3/4"
M6 Bolt or Nut Wrench—10mm	M8 Bolt or Nut Wrench—13mm	M10 Bolt or Nut Wrench—17mm	M12 Bolt or Nut Wrench—19mm	M14 Bolt or Nut Wrench—22mm



Not for
Reproduction

**IT IS THE POLICY OF BRIGGS & STRATTON CORP. TO IMPROVE ITS PRODUCTS
WHENEVER IT IS POSSIBLE AND PRACTICAL TO DO SO. WE RESERVE THE RIGHT TO
MAKE CHANGES OR ADD IMPROVEMENTS AT ANY TIME WITHOUT INCURRING ANY
OBLIGATION TO MAKE SUCH CHANGES ON PRODUCTS.**

Briggs & Stratton Power Products Group

12301 W. Wirth Street
Wauwatosa, WI, 53222 USA

www.BRIGGSandSTRATTON.com

© Copyright 2012 by Briggs & Stratton Corporation
Milwaukee, WI, USA. All rights reserved