

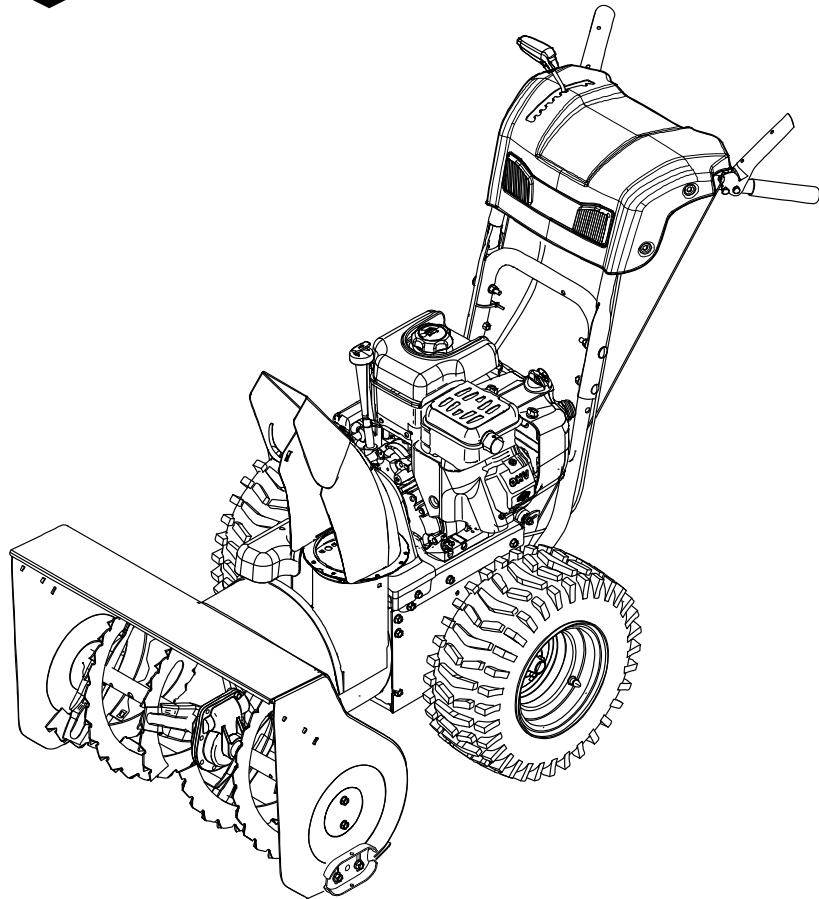

# Parts Manual



## **BH1730SE** **30" Dual Stage Snowthrower**

### **Models**

<b>Mfg. No.</b>	<b>Description</b>
1696256-00	BH1730SE, B&S 16.5TP 30" Dual Stage Snowthrower (CE) (2012)

**Manual Part No.** 1755486

Revision -

Rev. Date: 7/13/2012



<b>PRODUCT COMPONENTS</b>	<b>PAGES</b>
Handles & Controls Group .....	4
Engine & Frame Group .....	8
Auger Housing Group .....	10
Auger Drive Group .....	12
Traction Drive Group .....	14
Wheels and Tires Group .....	16
Decals Group .....	18
Discharge Chute Group .....	20
Gear Case Assembly .....	22
<b>Torque Specification Chart .....</b>	<b>Inside Back Cover</b>

# Handles & Controls Group

NOTE: Unless noted otherwise,  
use the standard hardware torque  
specification chart.

2990564

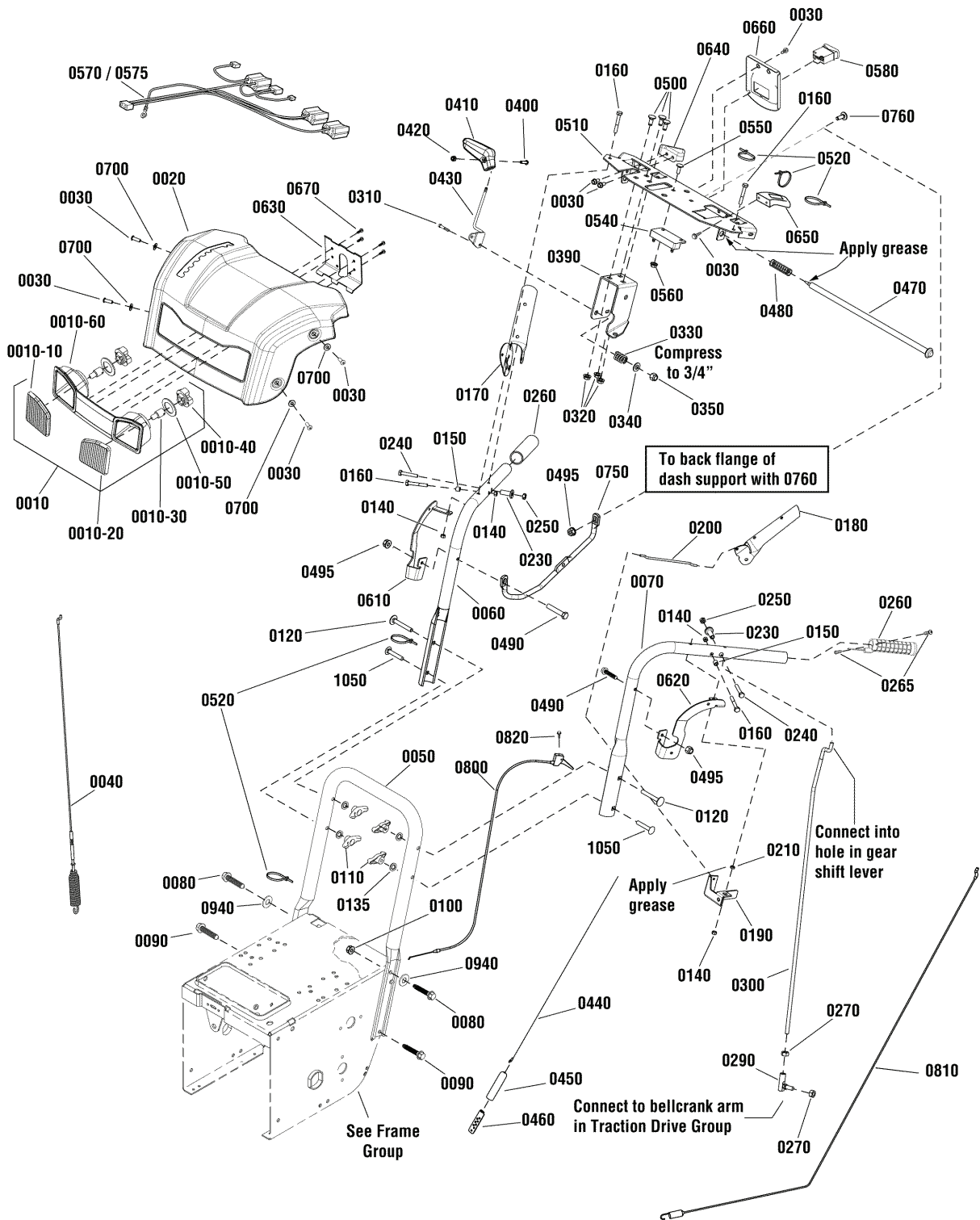

The above parts group applies to the following Mfg. Nos.:  
1696256-00 - BH1730SE

## Handles & Controls Group

REF NO	PART NO.	QTY.	DESCRIPTION
0010	1739686YP	1	LIGHT BAR ASSEMBLY
0010-10	-----	1	LENS, RH (Not a serviceable part, included with Ref. No. 0010)
0010-20	-----	1	LENS, LH (Not a serviceable part, included with Ref. No. 0010)
0010-30	1739689YP	2	LAMP, Halogen, 12V 20W
0010-40	1736180YP	2	SOCKET & GASKET ASSEMBLY, Headlight
0010-50	-----	2	GASKET, Single, Twin Light (Not a serviceable part, included with Ref. No. 0010-40)
0010-60	-----	2	BEZEL, Light, Panel (Not a serviceable part, included with Ref. No. 0010)
0020	1739345BSYP	1	COVER, Panel, Remote Deflector
0030	1960556SM	7	SCREW, Pan Head, Torx, 1/4-20 x 3/4, Taptite
0040	1732471SM	1	CABLE & SPRING ASSEMBLY, Auger Drive, RH
0050	1737274AYP	1	HANDLE, Lower
0060	1737531AYP	1	HANDLE, Upper, R.H.
0070	1737532AYP	1	HANDLE, Upper, L.H.
0080	1921333SM	2	CAPSCREW, Hex Head, 5/16-18 x 1, G5
0090	1664847SM	2	CAPSCREW, Hex Washer Head Taptite, 5/16-18 x 3/4
0100	1935048SM	2	NUT, Hex Flange Two Way Locking, 5/16-18
0110	7035744YP	4	WINGKNOB, 5/16-18
0120	1750299YP	2	BOLT, Carriage, Locking, 5/16-18 x 2-1/4
0135	7090391SM	2	Washer, Locking, Internal Teeth, 5/16
0140	1920397SM	4	NUT, Hex Lock, 1/4-20
0150	1678392SM	2	SPACER
0160	1921962SM	4	CAPSCREW, Hex Head, 1/4-20 x 1-3/4, G5
0170	1739783BMYP	1	LEVER, Clutch, RH
0180	1739782BMYP	1	LEVER, Clutch, LH
0190	1733505BMYP	1	BRACKET, Pivot, Free Hand
0200	1736360YP	1	ROD, Hold Down, 5/32 Dia., 5-5/8 Lg
0210	1733095SM	1	SPACER, 1/4 ID
0230	1736542YP	2	SPACER, Stepped
0240	1753529YP	2	BOLT, Shoulder, Hex Washer Head, 1/4 x 1-1/2
0250	1933896SM	2	NUT, Nylock, 10-24
0260	1738124YP	2	HAND GRIP
0265	703044	4	SCREW, Square, 1/8-20 x 1/32
0270	2820263SM	2	NUT, Hex, 5/16-24
0290	1739290YP	1	BALL JOINT, Quick Release
0300	1737331YP	1	ROD, Speed Select
0310	1923701SM	1	CAPSCREW, Hex Head, 3/8-16 x 2, G5
0320	1931277SM	3	NUT, Hex Flange Whiz Lock, 5/16-18
0330	50786MA	1	SPRING, 1/2 Dia. x 3/4
0340	1918266SM	1	WASHER, 3/8 x 13/16 OD
0350	1919439SM	1	NUT, Hex Lock, 3/8-16
0390	1737684YP	1	BRACKET, Controls
0400	1960589SM	1	SCREW, Round Head Phillips, #10-24 x 3/4
0410	1733192SM	1	KNOB, Slot Speed

### Footnotes

The above parts group applies to the following Mfg. Nos.:

1696256-00 - BH1730SE

# Handles & Controls Group

NOTE: Unless noted otherwise,  
use the standard hardware torque  
specification chart.

2990564

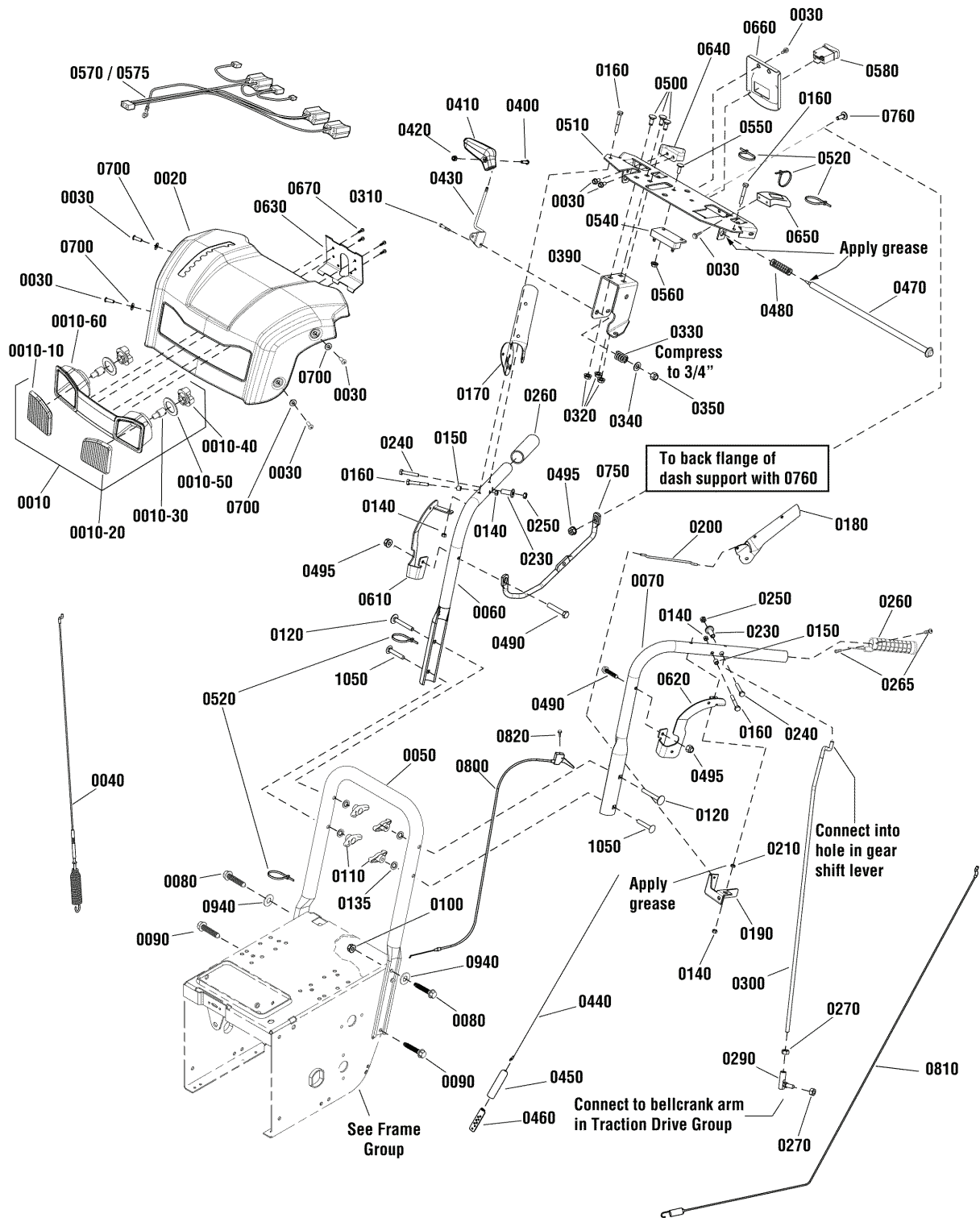

The above parts group applies to the following Mfg. Nos.:  
1696256-00 - BH1730SE

## Handles & Controls Group

REF NO	PART NO.	QTY.	DESCRIPTION
0420	1933896SM	1	NUT, Nylock, 10-24
0430	1736836YP	1	SPEED LEVER ASSEMBLY
0440	1502113MA	1	CABLE, Handle
0450	308146MA	1	BOOT, Spring End Cover, 4-1/16 Lg
0460	313441MA	1	BRACKET, Cable Adjusting
0470	1736363YP	1	ROD & SPRING ASSEMBLY
0480	2108360SM	1	SPRING, Compression, 017/32 ID x 2-1/4 Lg
0490	1921962SM	2	CAPSCREW, Hex Washer Head, Taptite, 1/4-20 x 1-3/4
0495	5025391SM	3	NUT, Hex Flange, 1/4-20
0500	1931333SM	3	BOLT, Carriage, 5/16-18 x 3/4
0510	1739500BMYP	1	SUPPORT, Dash
0520	1701011SM	5	TIE, Self Locking, 7-5/16 Lg
0540	1724037SM	1	RESISTOR BLOCK
0550	1931317SM	1	BOLT, Carriage, 1/4-20 x 3/4
0560	1960685SM	1	NUT, 1/4-20
0570	1750773YP	1	HARNESS
0575	1750774YP	1	HARNESS, High/Off/Low, HHG
0580	1752242YP	1	SWITCH, Heated Hand Grip, On/Off
0610	1739663BMYP	1	BRACKET, Mounting, Dash, R.H.
0620	1739664BMYP	1	BRACKET, Mounting, Dash, L.H.
0630	1739666BMYP	1	BRACKET, Light Mounting
0640	1739483AYP	1	POD, Chute Rotation, RH
0650	1739484AYP	1	POD, Deflector Control
0660	1739861AYP	1	BRACKET, Switch
0670	7091105YP	4	SCREW, Hex Washer Machine, #10-16 x 1/2
0700	1921319SM	4	WASHER, 1/4 x 5/8 OD
0750	1737552YP	1	BRACE
0760	7091530SM	1	BOLT, Carriage, 1/4-20 x 3/4
0800	1737510YP	2	CABLE, Steering Control
0810	1737511YP	1	CABLE, Traction Drive
0820	7073145YP	2	BOLT, Oval Head, 10-24 x 1-1/2
0940	71071MA	2	WASHER, 11/32 x 11/16 OD
1050	7091189YP	2	BOLT, Carriage. 5/16-18 x 2, G2

## Footnotes

The above parts group applies to the following Mfg. Nos.:

1696256-00 - BH1730SE

# Engine & Frame Group

NOTE: Unless noted otherwise,  
use the standard hardware torque  
specification chart.

2990429

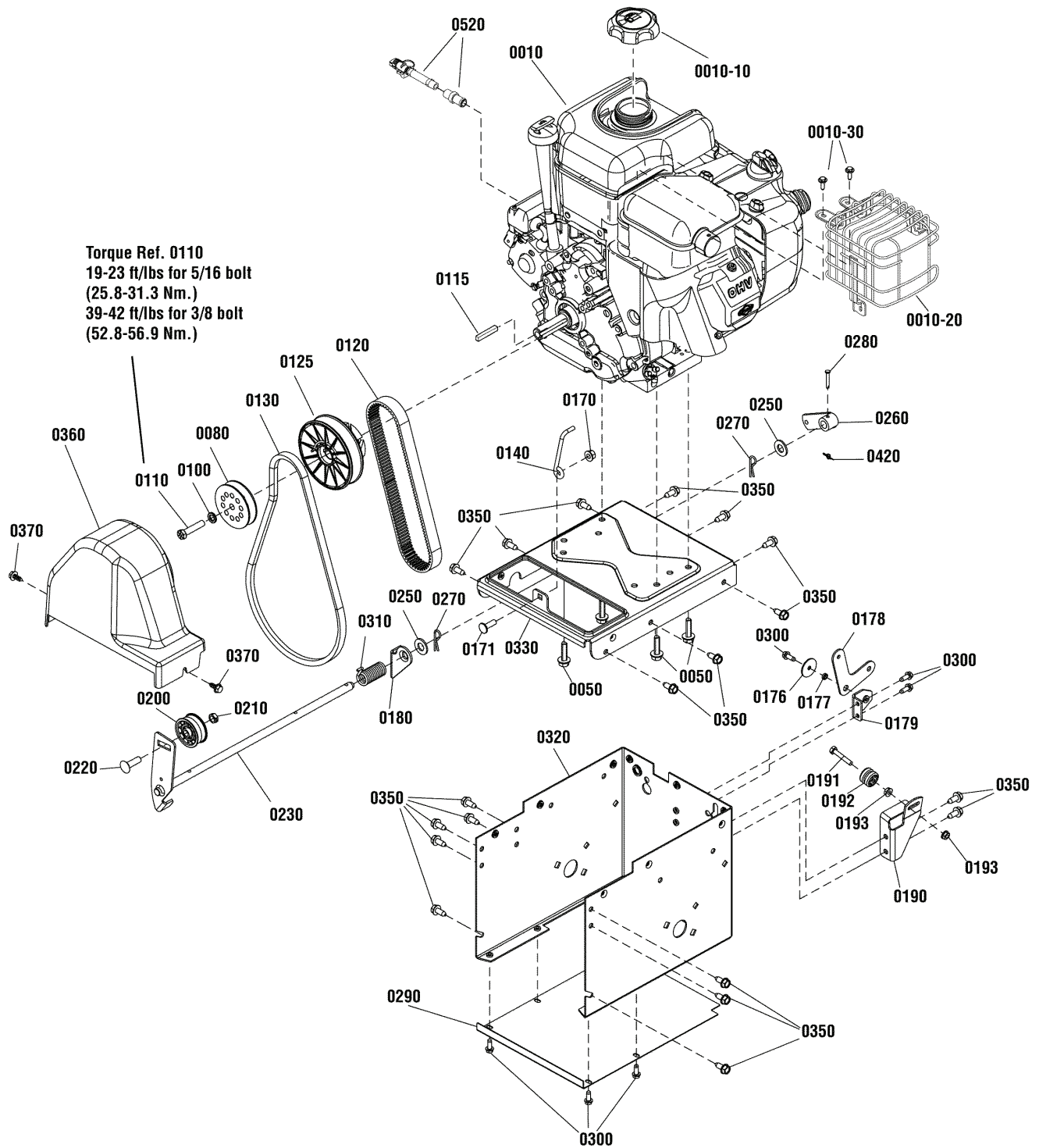

The above parts group applies to the following Mfg. Nos.:  
1696256-00 - BH1730SE



## Engine & Frame Group

REF NO	PART NO.	QTY.	DESCRIPTION
0010	21M314-0129-H1	1	* ENGINE, 16.5TP Briggs & Stratton (Engine Model: 21M314-0129-H1)
0010-10	795027	1	CAP, Fuel
0010-20	796384	1	GUARD, Muffler (Includes Ref. No 0010-30)
0010-30	699234	4	SCREW, Muffler Guard
0050	75246GS	4	CAPSCREW, Hex Head, Trilobular, 3/8-16 x 1-1/4
0080	1737509YP	1	PULLEY ASSEMBLY
0100	1916965SM	1	LOCKWASHER, Spring 3/8
0110	2860768YP	1	CAPSCREW, Hex Head, 3/8-24 X 1-3/4, G8
0115	2157427SM	1	KEY, Parallel
0120	1737220YP	1	V-BELT, Multi Speed
0125	1733968YP	1	PULLEY ASSEMBLY
0130	585416MA	1	BELT, Auger, V4L 38.10 MF 05-10B
0140	1737377YP	1	STOP, Belt
0170	1960684SM	1	NUT, Hex KEPS, Conical Washer, 5/16-18
0171	1931335SM	1	BOLT, Carriage, 5/16-18 x 1 G5
0176	1960151SM	1	WASHER, 1/4 x 1-1/4 x 1/16
0177	1733095SM	1	SPACER, Powdered Metal
0178	1737329YP	1	BELLCRANK
0179	1737328AYP	1	BRACKET, Lower
0180	1737297YP	1	BRACKET, Support, Auger Idler
0190	1737347AYP	1	BRACKET, Guide Wheel
0191	1922837SM	1	CAPSCREW, Hex Head, 1/4-20 x 1-1/2 G5
0192	579860MA	1	SPOOL CABLE, Auger Control
0193	192432GS	2	NUT, Lock, Serrated, 1/4-20
0200	1502120MA	1	IDLER, Plastic, Ball Bearing
0210	1960251SM	1	NUT, Hex Jam, 3/8-16
0220	585781MA	1	BOLT, Carriage, 3/8-16 x 1-1/4
0230	1737296YP	1	IDLER, Auger
0250	1960027SM	2	WASHER, 1/2" Flat
0260	1733451SM	1	BRACKET & HUB ASSEMBLY, Spring
0270	0031X6MA	2	PIN, Hair
0280	1736381YP	1	PIN, Clevis
0290	1737221AYP	1	PANEL, Bottom
0300	1927429SM	7	SCREW, Hex Washer Head Taptite, 1/4-20 x 5/8
0310	1737350YP	1	SPRING, Torsional
0320	1737106BSYP	1	FRAME BOX
0330	1754136BSYP	1	PLATE, Engine Mount
0350	1664847SM	19	SCREW, Hex Washer Head Taptite, 5/16-18 x 3/4
0360	1750551YP	1	COVER, Belt
0370	1751355YP	2	SCREW, Hex Washer Head, SEMS, Taptite, 1/4-20 x 3/4
0420	7023590SM	1	COTTER PIN, 1/4" Self Locking
0520	1751106YP	1	OIL DRAIN ASSEMBLY

### Footnotes

Note\* To verify your specific engine model, please reference the ID Tag located on your engine. See your local Briggs & Stratton distributor for parts and service.

**The above parts group applies to the following Mfg. Nos.:**

1696256-00 - BH1730SE

## Auger Housing Group

NOTE: Unless noted otherwise,  
use the standard hardware torque  
specification chart.

2990425

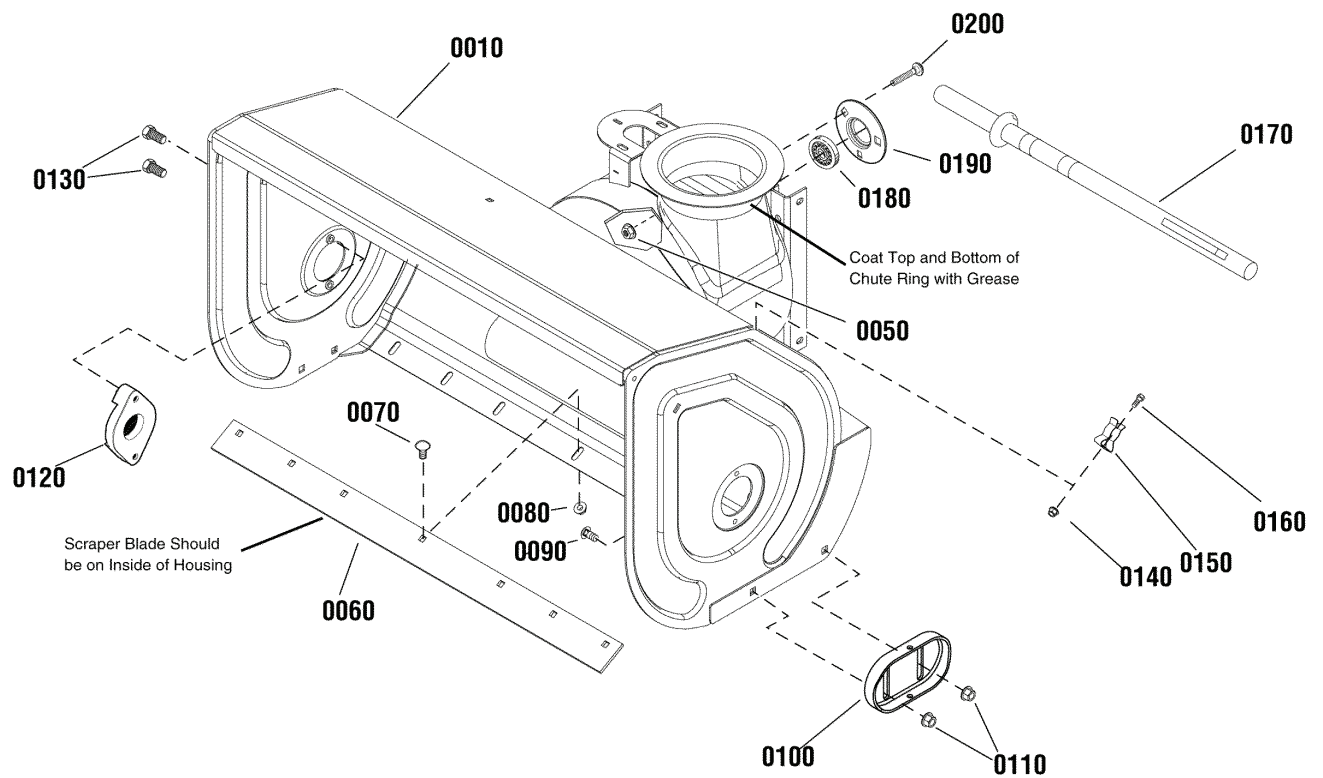

The above parts group applies to the following Mfg. Nos.:

1696256-00 - BH1730SE

## **Auger Housing Group**

---

<b>REF NO</b>	<b>PART NO.</b>	<b>QTY.</b>	<b>DESCRIPTION</b>
0010	1687684YP	1	AUGER HOUSING, 30
0050	1739305YP	3	NUT, Hex Flange, ESNA, 5/16-18
0060	1732385BMYP	1	BLADE, Scraper, 30
0070	1960699SM	7	BOLT, Carriage, Short Neck, 5/16-18 x 5/8, G5
0080	1935048SM	7	NUT, Hex Flange, Two Way Lock, 5/16-18
0090	7091790YP	4	BOLT, Carriage, Short Neck, 3/8-16 x 1-1/4
0100	1750222YP	2	SKID SHOE
0110	1960687SM	4	NUT, Hex Flange, ESNA, 3/8-16
0120	53757MA	2	BEARING, Auger Shaft
0130	25X021MA	4	SCREW, Hex Washer Head, Taptite, 5/16-18 x 3/4
0140	15X146MA	2	NUT, Nylock, 10 x 24
0150	1736620YP	2	CLAMP
0160	1960569SM	2	SCREW, Truss Head Torx, #10-24 x 3/8
0170	1736094YP	1	BRUSH, Cleanout
0180	2108202SM	1	BEARING, Ball, 3/4 ID x 1-3/4 OD
0190	1665982SM	1	RETAINER, Bearing
0200	1931333SM	3	BOLT, Carriage, Short Neck, 5/16-18 x 3/4, G5

### **Footnotes**

---

**The above parts group applies to the following Mfg. Nos.:**

1696256-00 - BH1730SE

# Auger Drive Group

NOTE: Unless noted otherwise,  
use the standard hardware torque  
specification chart.

2990426\_2990552

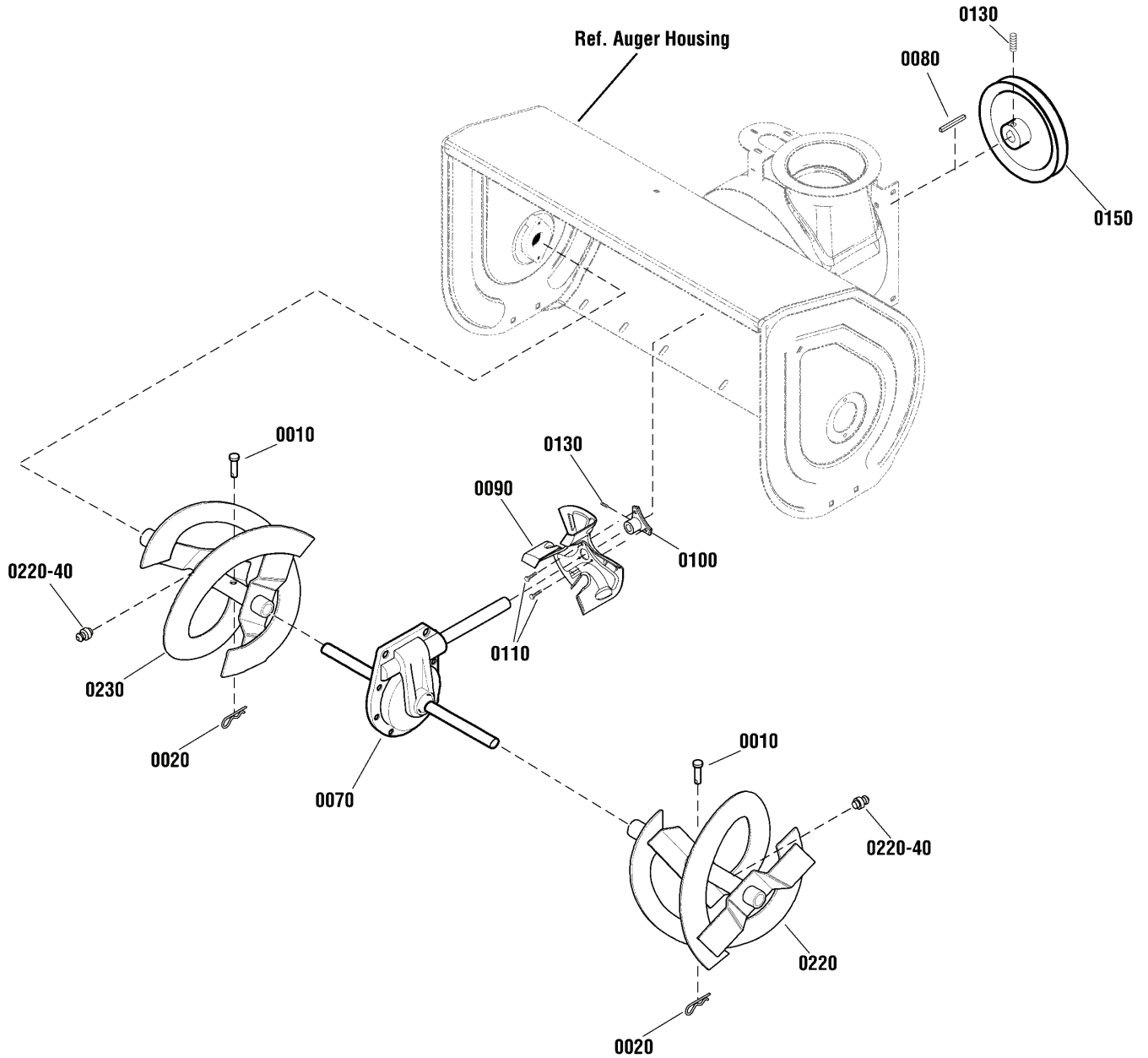

The above parts group applies to the following Mfg. Nos.:  
1696256-00 - BH1730SE

## **Auger Drive Group**

---

<b>REF NO</b>	<b>PART NO.</b>	<b>QTY.</b>	<b>DESCRIPTION</b>
0010	1739295YP	2	PIN, Sheer, 1/4 x 1-3/4
0020	1739292YP	2	PIN, Cotter, 3/16
0070	1755492YP	1	GEAR CASE ASSEMBLY, 30"
0080	2818312SM	2	KEY, Woodruff
0090	1739094AYP	1	IMPELLER
0100	1739073YP	1	HUB, Impeller
0110	1924856SM	3	SCREW, Hex Washer Head, Taptite, 5/16-18 x 1/2
0130	7090848SM	3	SET SCREW, Socket Head, 5/16-18 x 1/2
0150	1752220YP	1	PULLEY, Auger
0180	1733406SM	2	SPACER, Auger, 1"
0220	1737079BJYP	1	AUGER, LH, 30" (Includes Ref. 0220-40)
0220-40	10104MA	1	FITTING, Grease
0230	1737078BJYP	1	AUGER, RH, 30" (Includes Ref. 0220-40)
--	1739821YP	1	KIT, Shear Bolt (Includes Ref. Nos. 0010 & 0020)

## **Footnotes**

---

**The above parts group applies to the following Mfg. Nos.:**

1696256-00 - BH1730SE

# Traction Drive Group

2987638

**NOTE:** Unless noted otherwise, use the standard hardware torque specification chart.

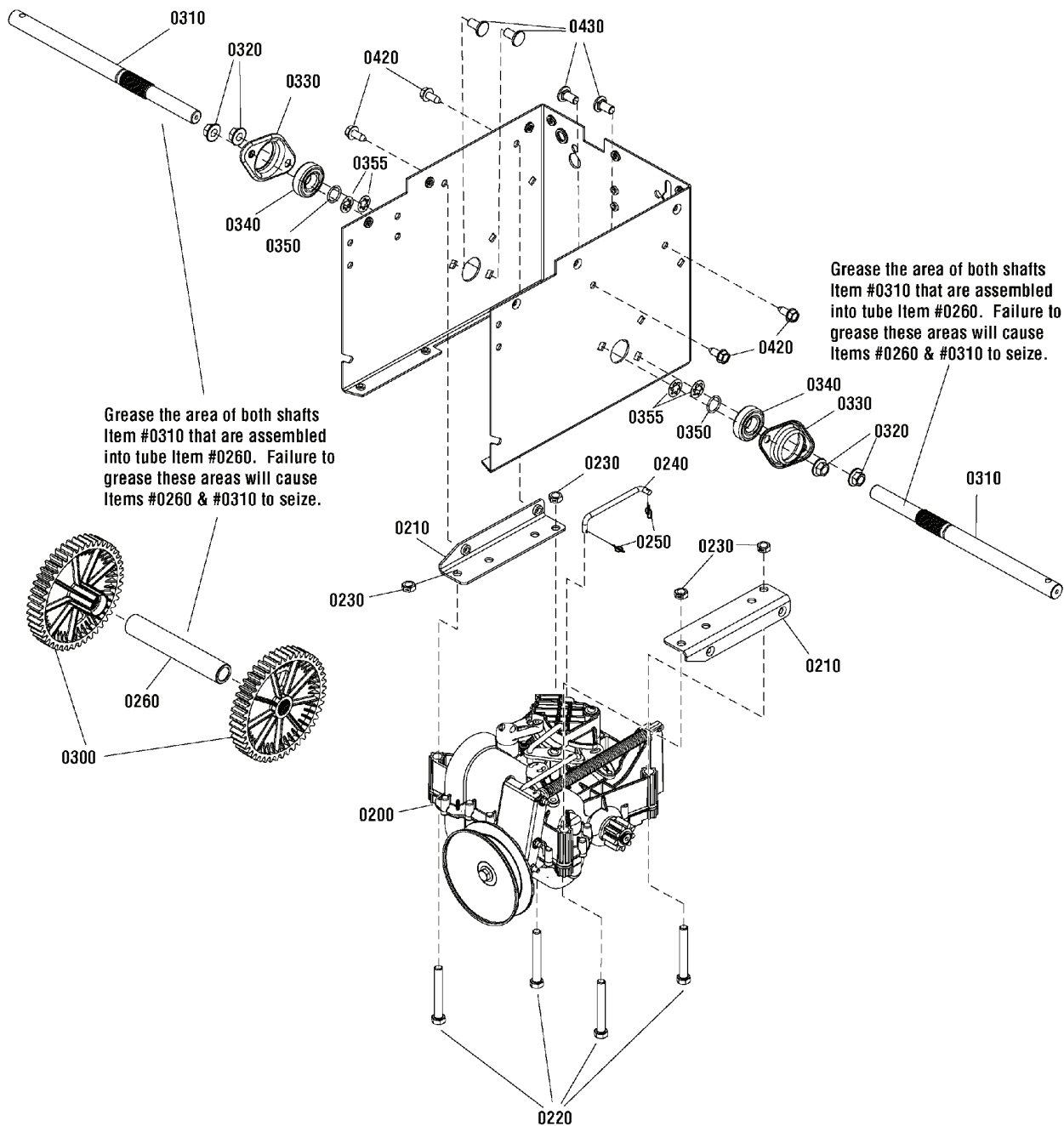

**The above parts group applies to the following Mfg. Nos.:**

1696256-00 - BH1730SE

## **Traction Drive Group**

---

<b>REF NO</b>	<b>PART NO.</b>	<b>QTY.</b>	<b>DESCRIPTION</b>
0200	1733972YP	1	TRANSMISSION, General Transmission H2
0210	1737267AYP	2	BRACKET
0220	7091557SM	4	CAPSCREW, Hex Head, 3/8C x 2-3/4 GR5
0230	1960251SM	4	NUT, Hex Jam, 3/8-16
0240	1737330YP	1	ROD, Speed Select
0250	7023590SM	2	COTTER PIN, 1/4" Self Locking
0260	1737310YP	1	TUBE, Support
0300	1737311YP	2	GEAR, Drive
0310	1737309YP	2	AXLE
0320	1928352SM	4	NUT, Hex Flange, Whiz Lock Large, 3/8-16
0330	1736396YP	2	RETAINER, Bearing
0340	53263MA	2	BEARING, Ball
0350	1737742YP	2	RING, Retaining
0355	7013847YP	4	RETAINER, Bolt 3/8"
0420	1664847SM	4	SCREW, Hex Washer Head Taptite, 5/16-18 X 3/4
0430	1737686YP	4	BOLT, Carriage, FH GR 5, 3/8-16 x 3/4

### **Footnotes**

Note\* See Transmission Assembly Group for detailed service parts.

---

**The above parts group applies to the following Mfg. Nos.:**

1696256-00 - BH1730SE

## Wheels and Tires Group

2990431

NOTE: Unless noted otherwise,  
use the standard hardware torque  
specification chart.

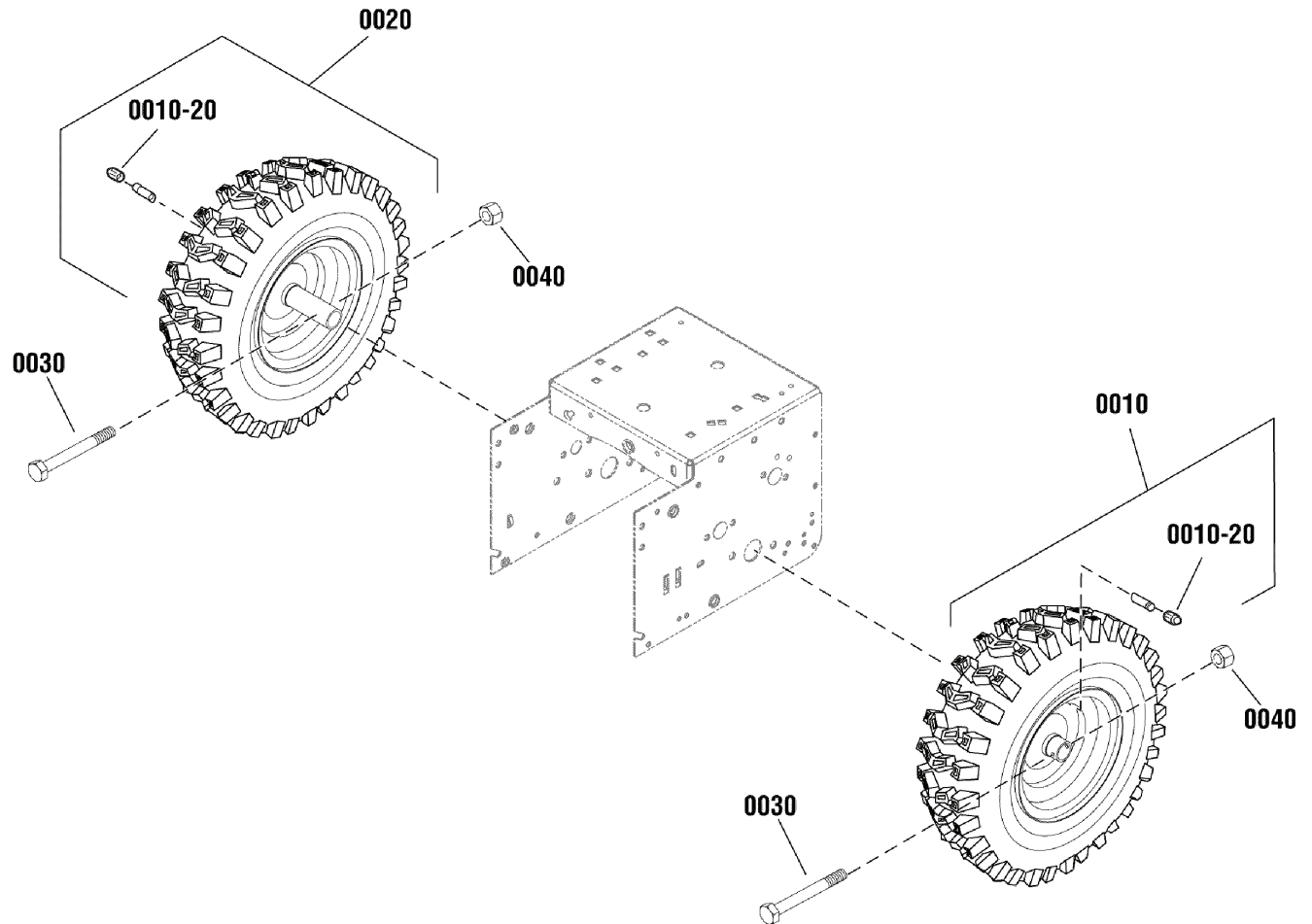

The above parts group applies to the following Mfg. Nos.:

1696256-00 - BH1730SE



## ***Wheels and Tires Group***

---

<b>REF NO</b>	<b>PART NO.</b>	<b>QTY.</b>	<b>DESCRIPTION</b>
0010	1754484YP	1	WHEEL & TIRE ASSEMBLY, L.H. (Includes Ref. No. 0010-20)
0020	1754485YP	1	WHEEL & TIRE ASSEMBLY, R.H. (Includes Ref. No. 0010-20)
0010-20	2172353SM	2	VALVE STEM & CAP
0030	577015MA	2	BOLT, Hex, 1/4-20 x 1-3/4
0040	15X145MA	2	NUT, Hex Nylock, 1/4-20

### **Footnotes**

---

**The above parts group applies to the following Mfg. Nos.:**

1696256-00 - BH1730SE

# Decals Group

NOTE: Unless noted otherwise, use the standard hardware torque specification chart.

2990432

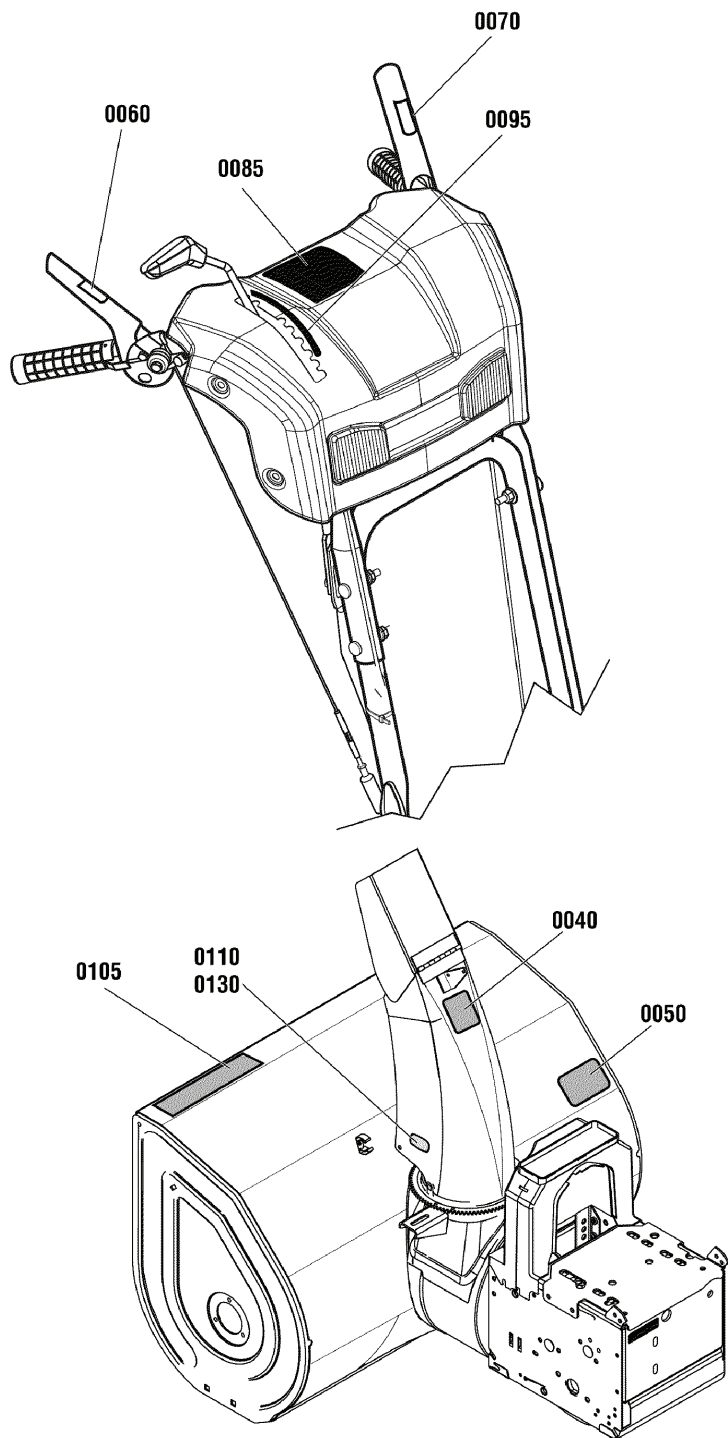

0040

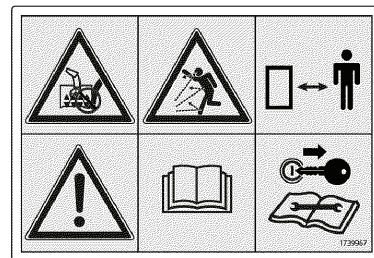

0050



0060



0070



0095

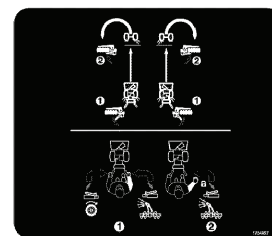

0085



0105

The above parts group applies to the following Mfg. Nos.:  
1696256-00 - BH1730SE

## ***Decals Group***

---

<b>REF NO</b>	<b>PART NO.</b>	<b>QTY.</b>	<b>DESCRIPTION</b>
0040	1727207SM	1	DECAL, Chute Warning, Export
0050	1737867YP	1	DECAL, Danger Auger Icons
0060	1751429YP	1	DECAL, Auger Control Symbols
0070	1751430YP	1	DECAL, Traction Control Symbols
0085	1754837YP	1	DECAL, Controls
0095	1751582YP	1	DECAL, Gear Shift
0105	1754509YP	1	DECAL, Auger Housing, BH1730SE
0110	1750926YP	1	DECAL, Logo, Chute, LH
0130	1750927YP	1	DECAL, Logo, Chute, RH

## **Footnotes**

---

**The above parts group applies to the following Mfg. Nos.:**

1696256-00 - BH1730SE

# Discharge Chute Group

NOTE: Unless noted otherwise, use the standard hardware torque specification chart.

2989774

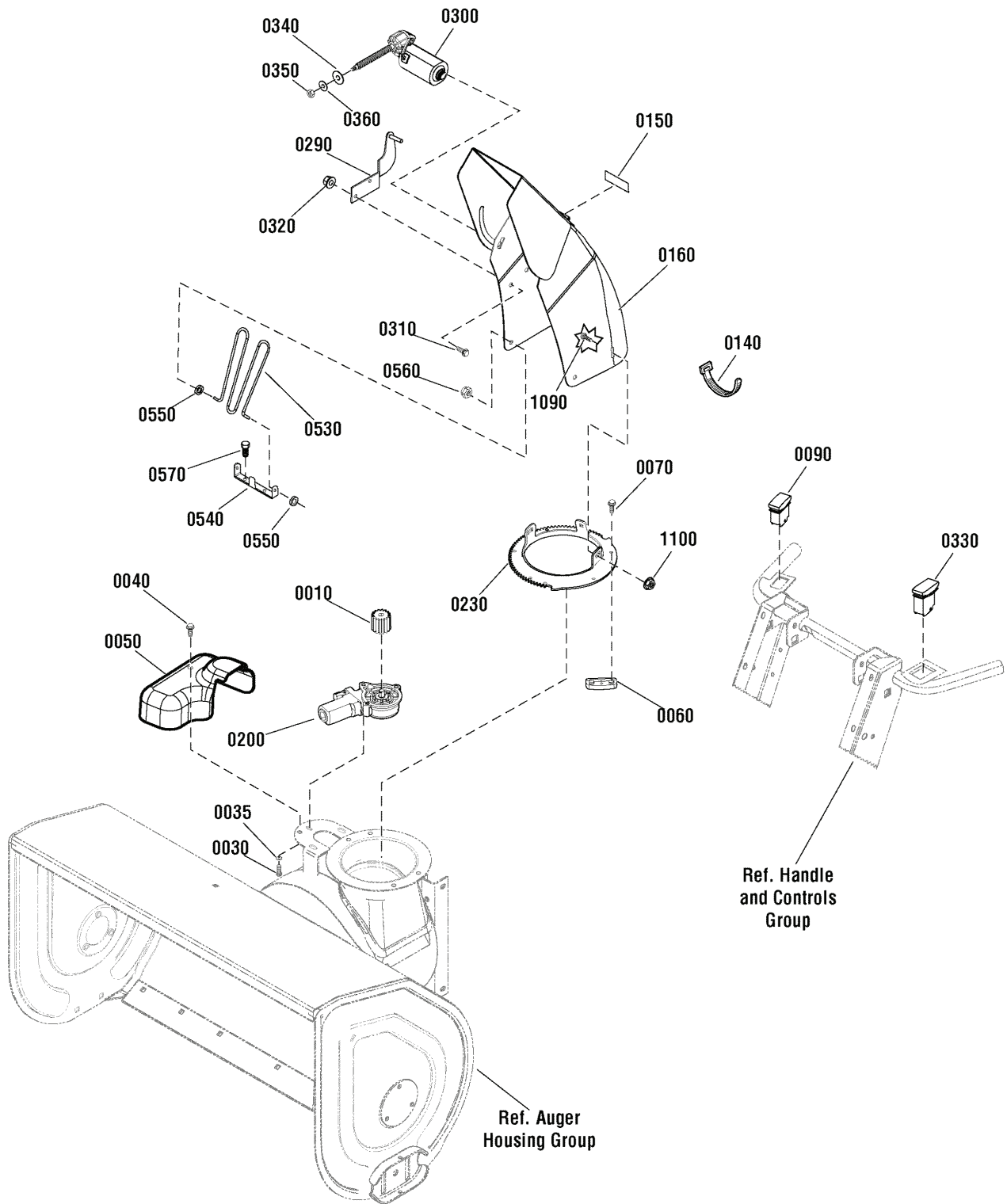

The above parts group applies to the following Mfg. Nos.:

1696256-00 - BH1730SE

## Discharge Chute Group

REF NO	PART NO.	QTY.	DESCRIPTION
0010	1728967SM	1	PINION
0030	1739621YP	3	SCREW, Torx Button Head, M5 x .8 x 14
0035	7091552SM	3	WASHER, Flat, 7/32
0040	1925592SM	1	SCREW, Hex Washer Head, Taptite, 1/4-20 x 3/4
0050	1752877YP	1	COVER, Electric Chute Rotation
0060	7011938SM	3	RETAINER, Spout
0070	1960001SM	6	SCREW, Hex Washer Head, Plastite, 10-14 x 5/8
0090	1737378YP	1	SWITCH, Chute Rotation
0140	1701011SM	1	TIE, Self Lock
0150	1733601SM	2	DECAL, Hinge
0160	1752841AYP	1	CHUTE
0200	1739309YP	1	MOTOR, Chute Rotation
0230	1737962BMYP	1	GEAR, Chute
0290	1738267BMYP	1	BRACKET, Weld Stud
0300	1737941YP	1	MOTOR, Chute Deflector
0310	1960715SM	2	SCREW, Truss Head, Torx Drive, 1/4-20 x 3/4
0320	1960694SM	2	NUT, Hex Flange, ESNA, 1/4-20
0330	1737379YP	1	SWITCH, Chute Deflector
0340	1738244YP	1	WASHER, Rubber
0350	1738245YP	1	NUT, LH
0360	5025154SM	1	WASHER, 1/4
0530	1733475SM	1	GUARD, Chute
0540	1752883YP	1	BRACKET, Chute Guard
0550	1738174YP	2	GROMMET
0560	1960140SM	2	NUT, Push, 3/16
0570	1925003SM	2	SCREW, Hex Washer Head, Taptite, 1/4-20 x 1/2
1090	1931317SM	3	BOLT, Carriage, Short Neck, 1/4-20 x 3/4, G5
1100	1960685SM	3	NUT, Hex KEPS, 1/4-20

## Footnotes

---

The above parts group applies to the following Mfg. Nos.:

1696256-00 - BH1730SE

## Gear Case Assembly

NOTE: Unless noted otherwise,  
use the standard hardware torque  
specification chart.

1752897

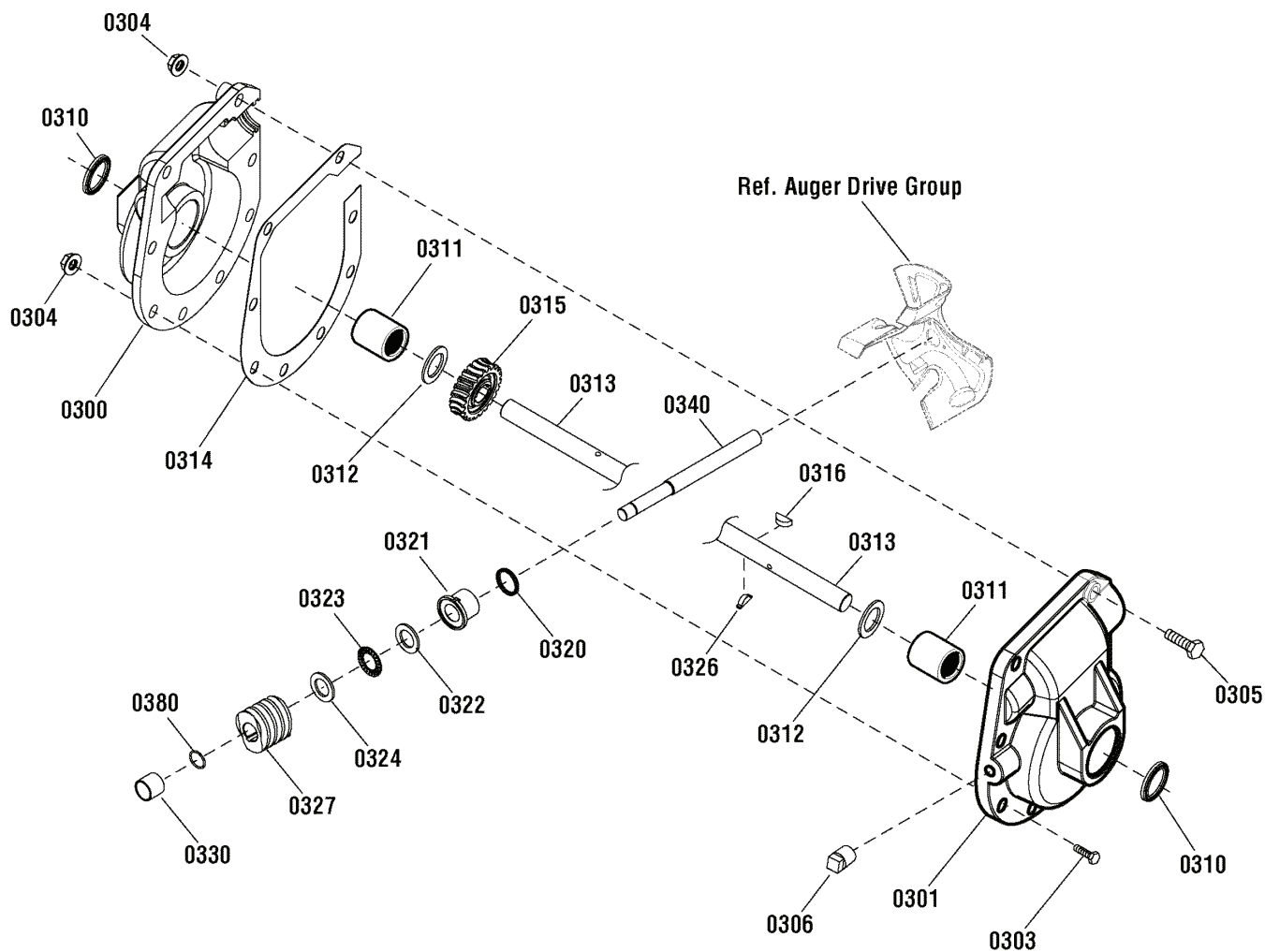

The above parts group applies to the following Mfg. Nos.:

1696256-00 - BH1730SE

## ***Gear Case Assembly***

<b>REF NO</b>	<b>PART NO.</b>	<b>QTY.</b>	<b>DESCRIPTION</b>
0300	1739063YP	1	GEARCASE, RH
0301	1739064YP	1	GEARCASE,LH
0303	910828MA	7	BOLT, Hex, 5/16-24 x 1
0304	71100MA	8	NUT, Hex Flange, 5/16-24, G5
0305	330434MA	1	CAPSCREW, Hex Head, 5/16-24 x 1-1/2
0306	53749MA	1	PLUG, 1/4-18
0310	780151MA	2	SEAL, Oil
0311	53743MA	2	Bearing, Sleeve, 1 x 1-1/4 x 1
0312	53748MA	2	WASHER, Flat, 1
0313	1754558YP	1	SHAFT, Auger
0314	897MA	1	GASKET
0315	1752500YP	1	GEAR, Worm, 22T 3.125 OD
0316	73905MA	1	KEY, Woodruff
0320	53737MA	1	RING, Quad
0321	583126MA	1	BEARING, Flange 3/4 ID x 1.128 OD
0322	48275MA	1	WASHER, Thurst
0323	50684MA	1	BEARING, Roll Thrust, 3/4 ID x 1-1/4 OD
0324	48275MA	1	WASHER, Thrust
0326	50795MA	1	KEY, Hi-Pro
0327	53732MA	1	WORMGEAR, 1-3/4 OD, 1-1/2"
0330	53731MA	1	BEARING, Sleeve, 3/4 ID x 7/8 OD
0340	1751544YP	1	SHAFT, Impeller
0380	1752515YP	1	RING, Retaining, 3/4

### **Footnotes**

---

**The above parts group applies to the following Mfg. Nos.:**

1696256-00 - BH1730SE









# Hardware Identification & Torque Specifications

Torque Specification Chart								
FOR STANDARD METRIC MACHINE HARDWARE (Tolerance ± 20%)								
Property Class	5.6		8.8		10.9		12.9	
	Class 5.6		Class 8.8		Class 10.9		Class 12.9	
Size Of Hardware	in/lbs		in/lbs		in/lbs		in/lbs	
	ft/lbs	Nm.	ft/lbs	Nm.	ft/lbs	Nm.	ft/lbs	Nm.
M3	5.88	.56	13.44	1.28	19.2	1.80	22.92	2.15
M4	13.44	1.28	30.72	2.90	43.44	4.10	52.56	4.95
M5	26.4	2.50	60.96	5.75	5.97	8.10	7.15	9.7
M6	44.64	4.3	7.3	9.9	10.3	14	12.1	16.5
M7	5.2	7.1	12.1	16.5	16.9	23	19.9	27
M8	7.7	10.5	17.7	24	25	34	29	40
M10	15	21	35	48	50	67	59	81
M12	26	36	61	83	86.2	117	103	140
M14	42	58	101	132	136	185	162	220
M16	64	88	147	200	210	285	250	340
M18	89	121	202	275	287	390	346	470
M20	126	171	290	390	405	550	486	660
M22	169	230	390	530	559	745	656	890
M24	217	295	497	375	708	960	840	1140
M27	320	435	733	995	1032	1400	1239	1680
M30	435	590	995	1350	1401	1900	1681	2280
M33	590	800	1349	1830	1902	2580	2278	3090
M36	759	1030	1740	2360	2441	3310	2935	3980
M39	988	1340	2249	3050	3163	4290	3798	5150

The guides and ruler furnished below are designed to help you select the appropriate hardware.

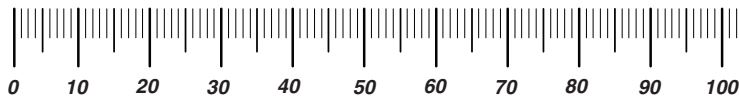

**Nut, M8**

Thread Diameter (mm)  
Inside Diameter (in) Threads per inch

**Nut, 1/2-16**

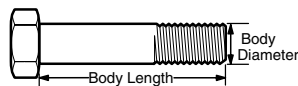

**Screw, M8- 1.25 x 25**

Thread Diameter (mm) Distance between threads (mm) Body Length (mm)  
Body Diameter Threads per inch Body Length (in)

**Screw, 1/2- 16 x 2**

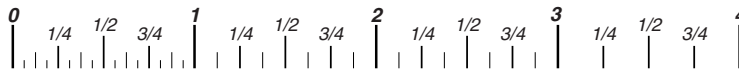

## Standard Hardware Sizing

When a washer or nut is identified as **1/2"** (M8), this is the *Nominal size*, meaning the *inside diameter* is 1/2 inch (8mm metric thread diameter); if a second number is present it represents the *threads per inch* (distance between threads).

When bolt or capscrew is identified as **1/2 - 16 x 2"** (M8 - 1.25 x 50 ), this means the *Nominal size*, or body diameter is 1/2 inch (8mm metric thread diameter), the second number, 16, represents the *threads per inch*, (*1.25 thread diameter*). The final number is the body length of the bolt or screw, 2 inches (50mm).

Torque Specification Chart						
FOR STANDARD MACHINE HARDWARE (Tolerance ± 20%)						
Hardware Grade	No Marks		SAE Grade 5		SAE Grade 8	
	SAE Grade 2		SAE Grade 5		SAE Grade 8	
Size Of Hardware	in/lbs		in/lbs		in/lbs	
	ft/lbs	Nm.	ft/lbs	Nm.	ft/lbs	Nm.
8-32	19	2.1	30	3.4	41	4.6
8-36	20	2.3	31	3.5	43	4.9
10-24	27	3.1	43	4.9	60	6.8
10-32	31	3.5	49	5.5	68	7.7
1/4-20	66	7.6	8	10.9	12	16.3
1/4-28	76	8.6	10	13.6	14	19.0
5/16-18	11	15.0	17	23.1	25	34.0
5/16-24	12	16.3	19	25.8	29	34.0
3/8-16	20	27.2	30	40.8	45	61.2
3/8-24	23	31.3	35	47.6	50	68.0
7/16-14	30	40.8	50	68.0	70	95.2
7/16-20	35	47.6	55	74.8	80	108.8
1/2-13	50	68.0	75	102.0	110	149.6
1/2-20	55	74.8	90	122.4	120	163.2
9/16-12	65	88.4	110	149.6	150	204.0
9/16-18	75	102.0	120	163.2	170	231.2
5/8-11	90	122.4	150	204.0	220	299.2
5/8-18	100	136	180	244.8	240	326.4
3/4-10	160	217.6	260	353.6	386	525.0
3/4-16	180	244.8	300	408.0	420	571.2
7/8-9	140	190.4	400	544.0	600	816.0
7/8-14	155	210.8	440	598.4	660	897.6
1-8	220	299.2	580	788.8	900	1,244.0
1-12	240	326.4	640	870.4	1,000	1,360.0

## NOTES

- These torque values are to be used for all hardware excluding: locknuts, self-tapping screws, thread forming screws, sheet metal screws and socket head setscrews.
- Recommended seating torque values for locknuts:
  - for prevailing torque locknuts - use 65% of grade 5 torques.
  - for flange whizlock nuts and screws - use 135% of grade 5 torques.
- Unless otherwise noted on assembly drawings, all torque values must meet this specification.

## Common Hardware Types

Hex Head Capscrew



Washer

Carriage Bolt



Lockwasher



Hex Nut

## Wrench & Fastener Size Guide

1/4" Bolt or Nut Wrench—7/16"	5/16" Bolt or Nut Wrench—1/2"	3/8" Bolt or Nut Wrench—9/16"	7/16" Bolt or Nut Wrench (Bolt)—5/8" Wrench (Nut)—11/16"	1/2" Bolt or Nut Wrench—3/4"
M6 Bolt or Nut Wrench—10mm	M8 Bolt or Nut Wrench—13mm	M10 Bolt or Nut Wrench—17mm	M12 Bolt or Nut Wrench—19mm	M14 Bolt or Nut Wrench—22mm



**IT IS THE POLICY OF BRIGGS & STRATTON CORP. TO IMPROVE ITS PRODUCTS  
WHENEVER IT IS POSSIBLE AND PRACTICAL TO DO SO. WE RESERVE THE RIGHT TO  
MAKE CHANGES OR ADD IMPROVEMENTS AT ANY TIME WITHOUT INCURRING ANY  
OBLIGATION TO MAKE SUCH CHANGES ON PRODUCTS.**

**Briggs & Stratton Power Products Group**

---

12301 W. Wirth Street  
Wauwatosa, WI, 53222 USA

[www.BRIGGSandSTRATTON.com](http://www.BRIGGSandSTRATTON.com)

© Copyright 2012 by Briggs & Stratton Corporation  
Milwaukee, WI, USA. All rights reserved