

Parts Manual for

SNAPPER®

22" SELF-PROPELLED ELECTRIC START MOWER NXT SERIES

<i>Model No.</i>	<i>Description</i>
7800722	ENXT22875E
7800580	NXT22875E
7800752	NXT22875EE
7800696	NXT22875EFC
7800782	NXT22875EEFC

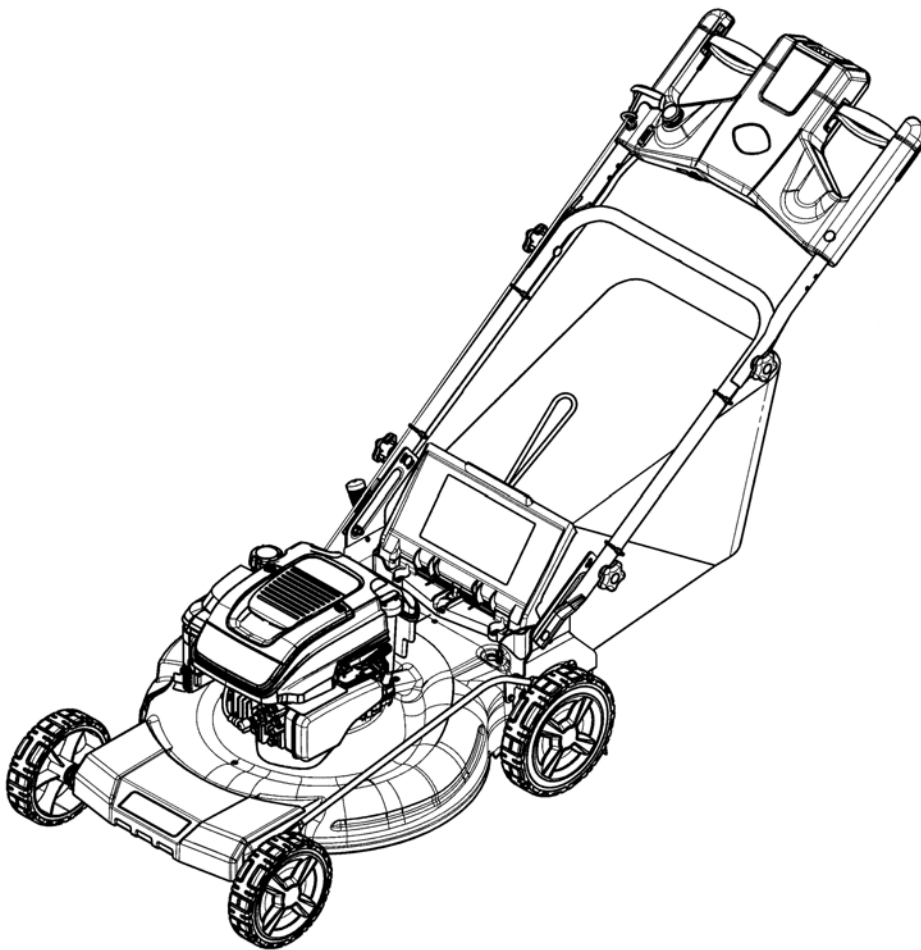

Briggs & Stratton Yard Power Products Group

535 Macon Road
McDonough, GA, 30253 U.S.A.
800-935-2967

Manual No. 7104329
Revision: C 2/9/2011

PAGE	GROUP
4	Handle & Controls Group (MY 2010)
6	Drive Control Assembly (MY 2010)
8	Handle & Controls Group, EHOc (MY 2011)
10	Drive Control Assembly, EHOc (MY 2011)
12	Mower Deck Group
14	Wheels Group
16	Engine, Blade & Grass Bag Group
18	Transmission Group
20	Decals

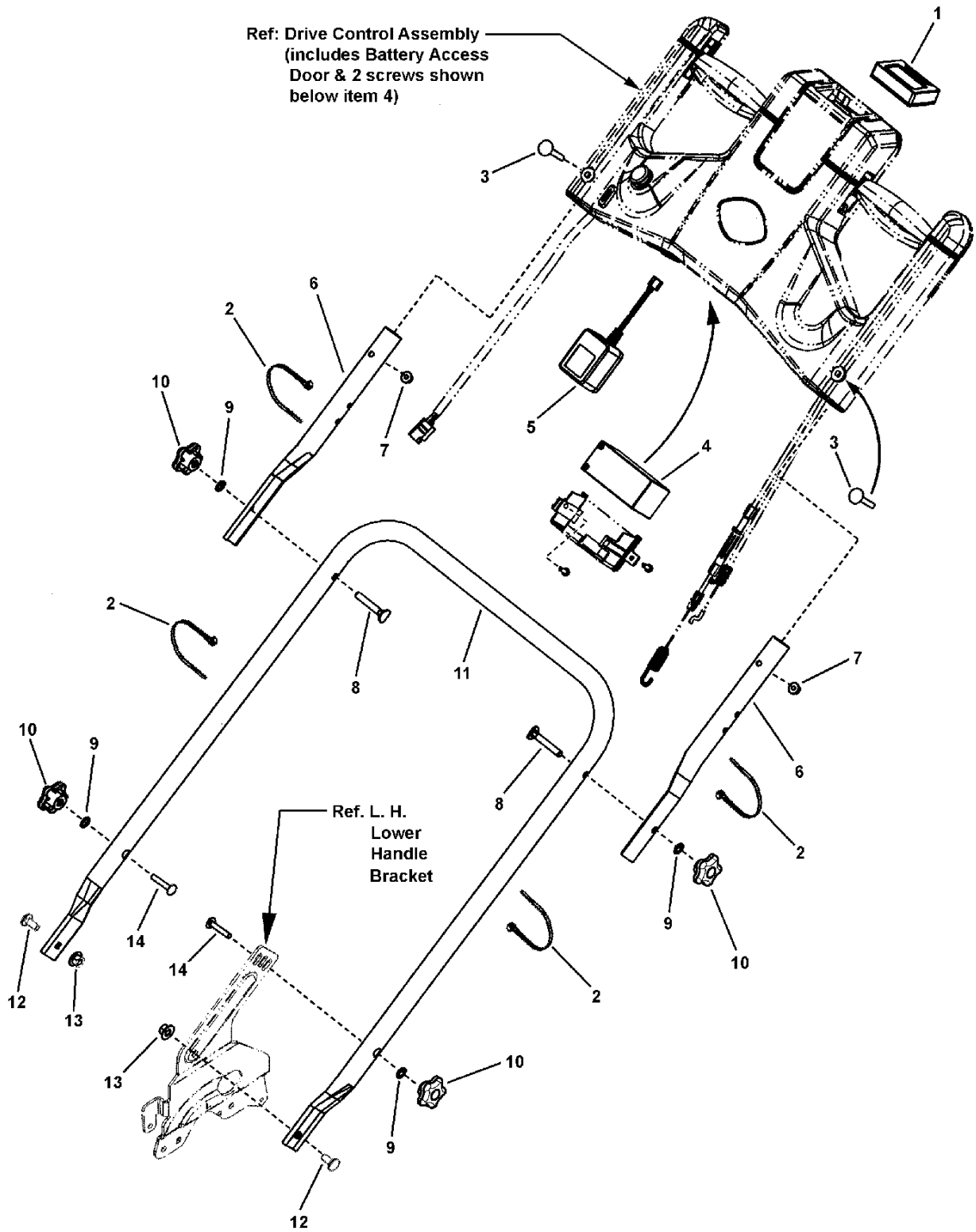

Item	Part No	Qty	Description
--	7501300	1	ASSEMBLY, Drive Control (MY 2010)
1	7103774	1	METER, Service Indicator
2	7024649	4	WIRE TIE, 11 Inch Standard Black Nylon
3	7090015	2	BOLT, 1/4-20 x 1-3/4" Round Head Square Neck, GR 2, YZ
4	7102931	1	BATTERY, 1.3A/Hr
5	7103988	1	CHARGER, Battery, 14V, 260MA
6	7300649BH	2	HANDLE, Connecting, 21"/22" WBM
7	2860694	2	NUT, 1/4-20 Hex Flange (Esna), YZ
8	7091189	2	BOLT, 5/16-18 x 2" Curved Head Square Neck, GR 2
9	7090391	4	WASHER, 5/16" Internal Tooth Lock
10	7102990	4	KNOB, Handle, 5-Prong (5/16-18 internal threads)
11	7301189BH	1	HANDLE, Lower, WBM, RD
12	723873	2	BOLT, 5/16-18 x 3/4" Round Head Short Square Neck, GR 5, YZ (was 1931333)
13	7090951	2	NUT, 5/16-18 Large Flange Center Lock, BZ
14	1931338	2	BOLT, 5/16-18 x 1-3/4" Round Head Square Neck Carriage

Footnotes:

Drive Control Assembly (MY 2010)

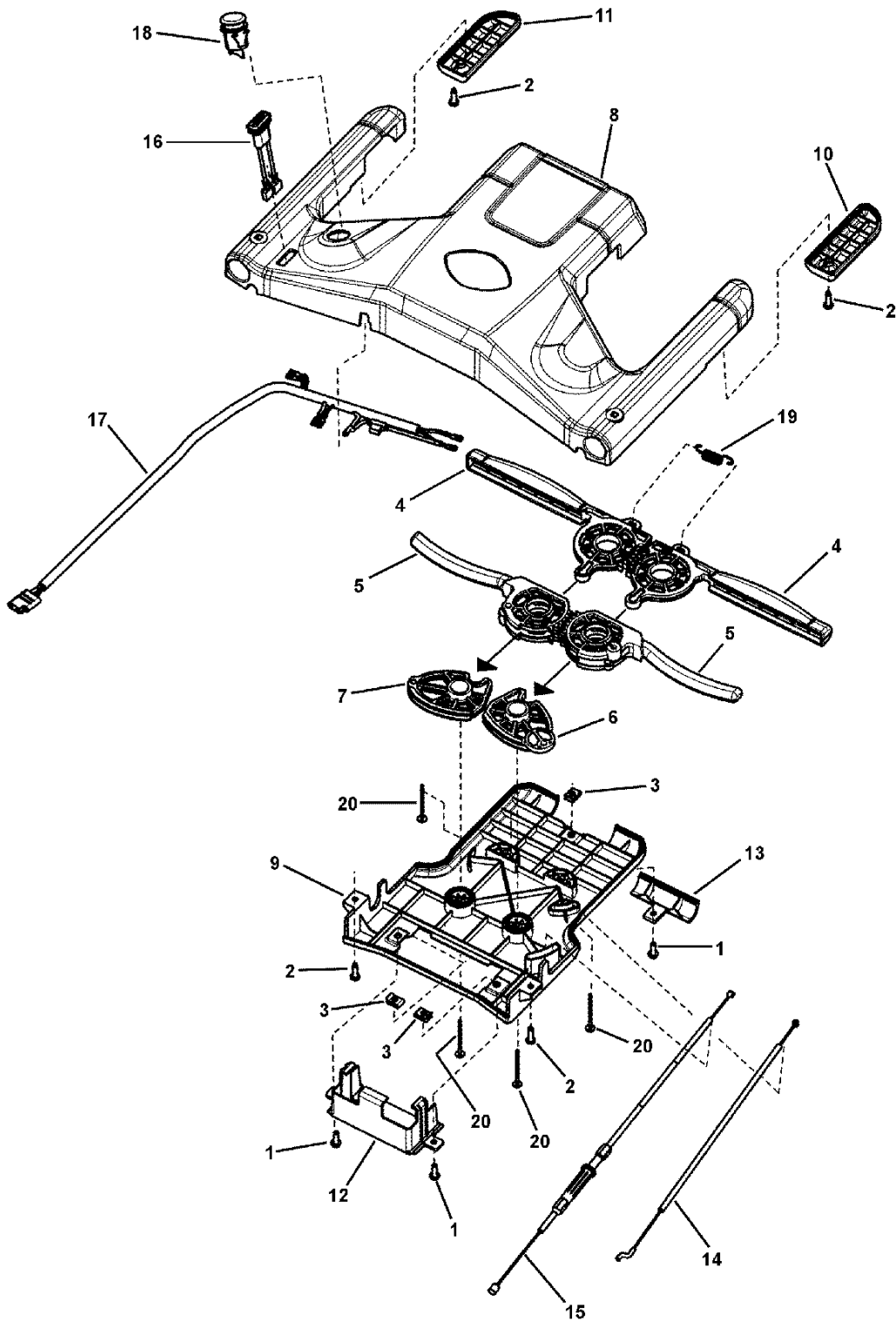

Item	Part No	Qty	Description
1	7091075	3	SCREW, #10-24 x 5/8" Hex Washer Self-Tap, GR 5 BZ
2	7091195	4	SCREW, #10-16 x 3/4" Pan Head Self-Tap Combo, BZ
3	1960593	3	NUT, #10-24 Speed Retainer w/extrusion
4	7102803	2	LEVER, Drive Control
5	7102804	2	LEVER, OPC, Control
6	7102805	1	CAM, Drive, LH
7	7102806	1	CAM, Drive, RH
8	7103324	1	CONTROL PANEL, TOP, MY Mower
9	7103325	1	CONTROL PANEL, Bottom, MY Mower
10	7103326	1	PANEL, Bottom Control, WBM, RH
11	7103327	1	PANEL, Bottom Control, WBM, LH
12	7103345	1	ACCESS DOOR, Battery Control Panel, WBM
13	7103456	1	PANEL, Access, Maintenance Reminder
14	7103769	1	CABLE, OPC, 2010 NXT
15	7103770	1	CABLE, Drive Control, 2010 NXT
16	7103930	1	HOUSING, Bridge Disconnect
17	7103932	1	HARNESS, Electric Start, NXT
18	7104001	1	SWITCH, Push Button Start
19	7104689	1	SPRING, Tension, Drive Control
20	7900081	4	SCREW, #10-16 x 2" Hi-Lo Cross Pan Head

Footnotes:

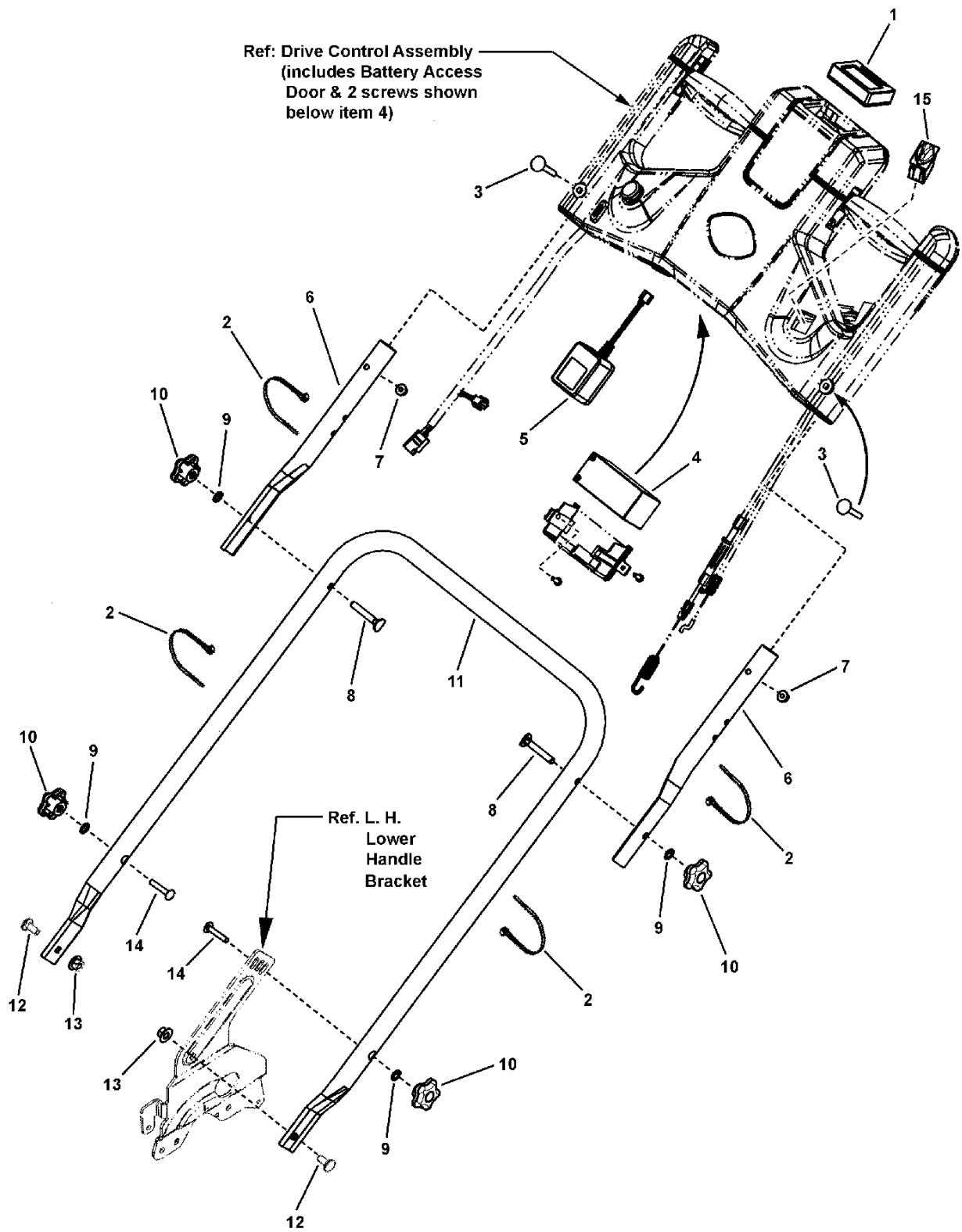

Handle & Controls Group, EHOc (MY 2011)

Item	Part No	Qty	Description
--	7502154	1	ASSEMBLY, Drive Control, EHOc, (MY2011) Walk
1	7103774	1	METER, Service Indicator
2	7024649	4	WIRE TIE, 11 Inch Standard Black Nylon
3	7090015	2	BOLT, 1/4-20 x 1-3/4" Round Head Square Neck, GR 2, YZ
4	7102931	1	BATTERY, 1.3A/Hr
5	7103988	1	CHARGER, Battery, 14V, 260MA
6	7300649BH	2	HANDLE, Connecting, 21"/22" WBM
7	2860694	2	NUT, 1/4-20 Hex Flange (Esna), YZ
8	7091189	2	BOLT, 5/16-18 x 2" Curved Head Square Neck, GR 2
9	7090391	4	WASHER, 5/16" Internal Tooth Lock
10	7102990	4	KNOB, Handle, 5-Prong (5/16-18 internal threads)
11	7301189BH	1	HANDLE, Lower, WBM, RD
12	723873	2	BOLT, 5/16-18 x 3/4" Round Head Short Square Neck, GR 5, YZ (was 1931333)
13	7090951	2	NUT, 5/16-18 Large Flange Center Lock, BZ
14	1931338	2	BOLT, 5/16-18 x 1-3/4" Round Head Square Neck Carriage
15	7104598	1	SWITCH, Rotary, EHOc

Footnotes:

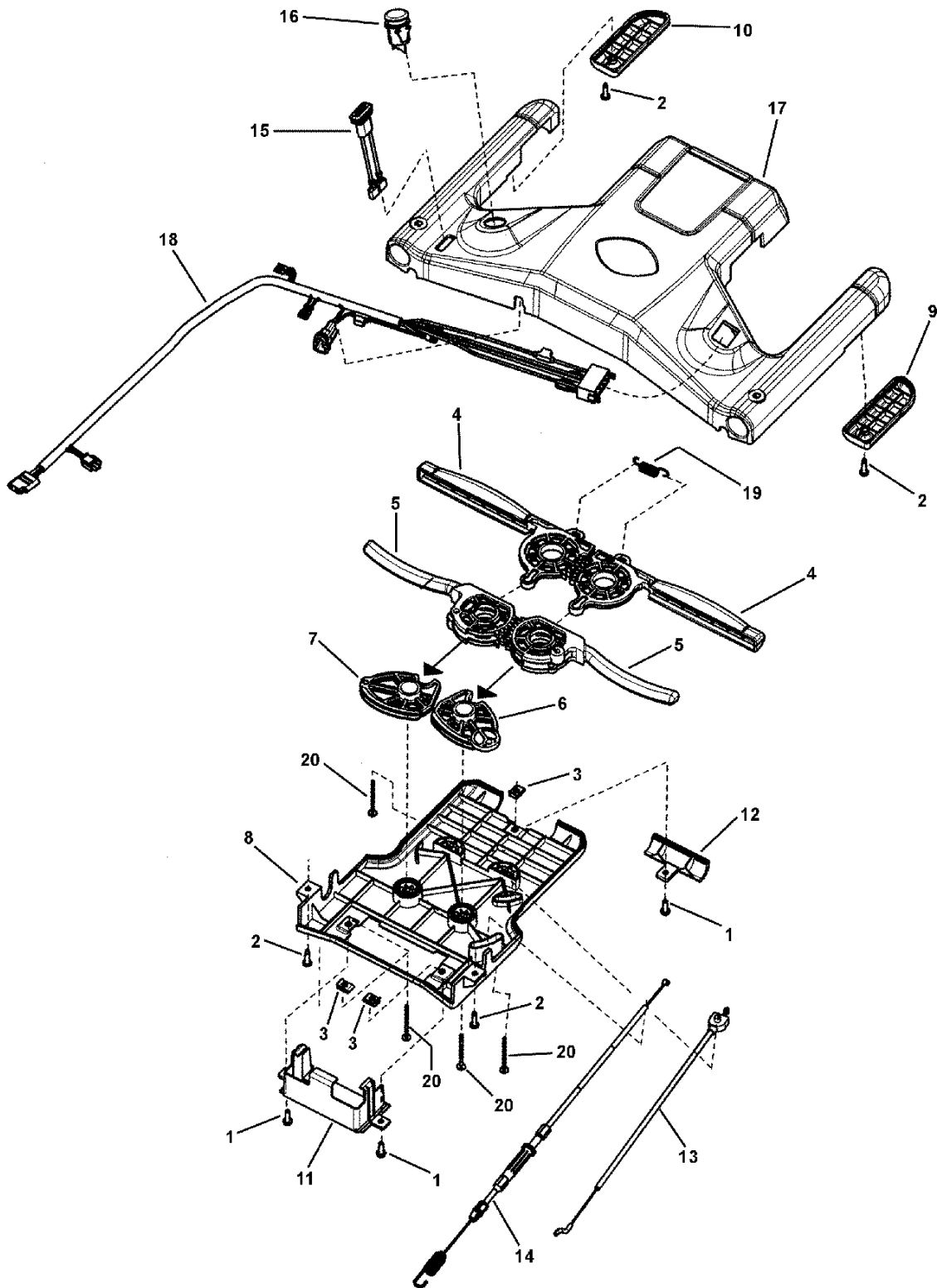

Drive Control Assembly, EHOc (MY 2011)

Item	Part No	Qty	Description
1	7091075	3	SCREW, #10-24 x 5/8" Hex Washer Self-Tap, GR 5 BZ
2	7091195	4	SCREW, #10-16 x 3/4" Pan Head Self-Tap Combo, BZ
3	1960593	3	NUT, #10-24 Speed Retainer w/extrusion
4	7102803	2	LEVER, Drive Control
5	7102804	2	LEVER, OPC, Control
6	7102805	1	CAM, Drive, LH
7	7102806	1	CAM, Drive, RH
8	7103325	1	CONTROL PANEL, Bottom, MY Mower
9	7103326	1	PANEL, Bottom Control, WBM, RH
10	7103327	1	PANEL, Bottom Control, WBM, LH
11	7103345	1	ACCESS DOOR, Battery Control Panel, WBM
12	7103456	1	PANEL, Access, Maintenance Reminder
13	7103769	1	CABLE, OPC, 2010 NXT
14	7103770	1	CABLE, Drive Control, 2010 NXT
15	7103930	1	HOUSING, Bridge Disconnect
16	7104001	1	SWITCH, Push Button Start
17	7104519	1	CONTROL PANEL, TOP
18	7104523	1	HARNESS, Electric Start, NXT, w/E-HOC
19	7104689	1	SPRING, Tension, Drive Control
20	7900081	4	SCREW, #10-16 x 2" Hi-Lo Cross Pan Head

Footnotes:

Item	Part No	Qty	Description
1	7600155D	1	DECK, 22", Rear Wheel Drive, Washout (Was 7301112D)
2	7300885BH	1	BRACKET, Lower Handle, LH, 22 WBM
3	7300915BH	1	BRACKET, Lower Handle, RH, 22 WBM (used on 7800580 & 7800696 models)
3	7301141BH	1	BRACKET, Lower Handle, Elec HOC, RH (used on 7800752 & 7800782 models)
4	7103298	1	COVER, Mulching
5	7103299	1	CHUTE, Side Discharge, 22" WBM
6	7103295	1	COVER, Front, Push/Rear Wheel Drive
7	7091020	3	PUSHNUT, 1/4"
8	7101067	1	ROD, Pivot
9	7900067	6	SCREW, 1/4-20 x .550 Self-Tap (Torx)
10	722507	1	SPRING, Torsion, Chute
11	7300855BM	1	BRACKET, Chute
12	7900073	2	BOLT, 1/4-20 x 1-1/2" Shoulder
13	7090699	4	BOLT, 1/4-20 x 3/4" Hex Flange Lock, GR 5
14	7103296	1	DEBRIS SHIELD, Front
15	7103323	1	GUARD, Rear 22"
16	722398	3	NUT, 1/4-20 Hex Flange Lock
17	7501541	1	ASSEMBLY, Door, 22" WBM
18	1960518	3	BOLT RETAINER, 1/4"
19	7091075	2	SCREW, #10-24 x 5/8" Hex Washer Face Self-Tap, GR 5
20	1960593	2	NUT, #10-24 Retainer Speed w/extrusion
21	7103453	1	PLUG, Mulching, 22" Deck
22	7900018	2	SCREW, Round Washer Head Torx, Hi-Lo
23	7090803	3	BOLT, 1/4-20 x 5/8" Flat Head Square Neck, GR 5
24	7023295	4	U-NUT, 1/4-20
25	7103293	1	BAFFLE, Rear, Rear Wheel Drive WBM
26	7104819	1	BELT COVER, Rear Drive (Was 7103294)
27	7900079	2	NUT, 3/16" Push
28	7301020	1	BAFFLE, Front
29	7103292	1	HINGE, Rear Discharge Door
30	7103309	1	SPRING, Torsion, Rear Door
31	7103322	1	ROD, Pivot, Rear Door
32	7501541	1	DOOR, Rear Discharge (Was 7103291)
33	7103957	1	WASHER, Hose
34	7103804	1	ADAPTOR, Washout Port, WBM
35	7103919	1	COUPLING, Hose
36	7091546	1	WASHER, 5/8" Internal Tooth Lock YZ (Was 7090880)
37	1960716	1	NUT, 5/8-11, NC-2B Black Hex Jam

Footnotes:

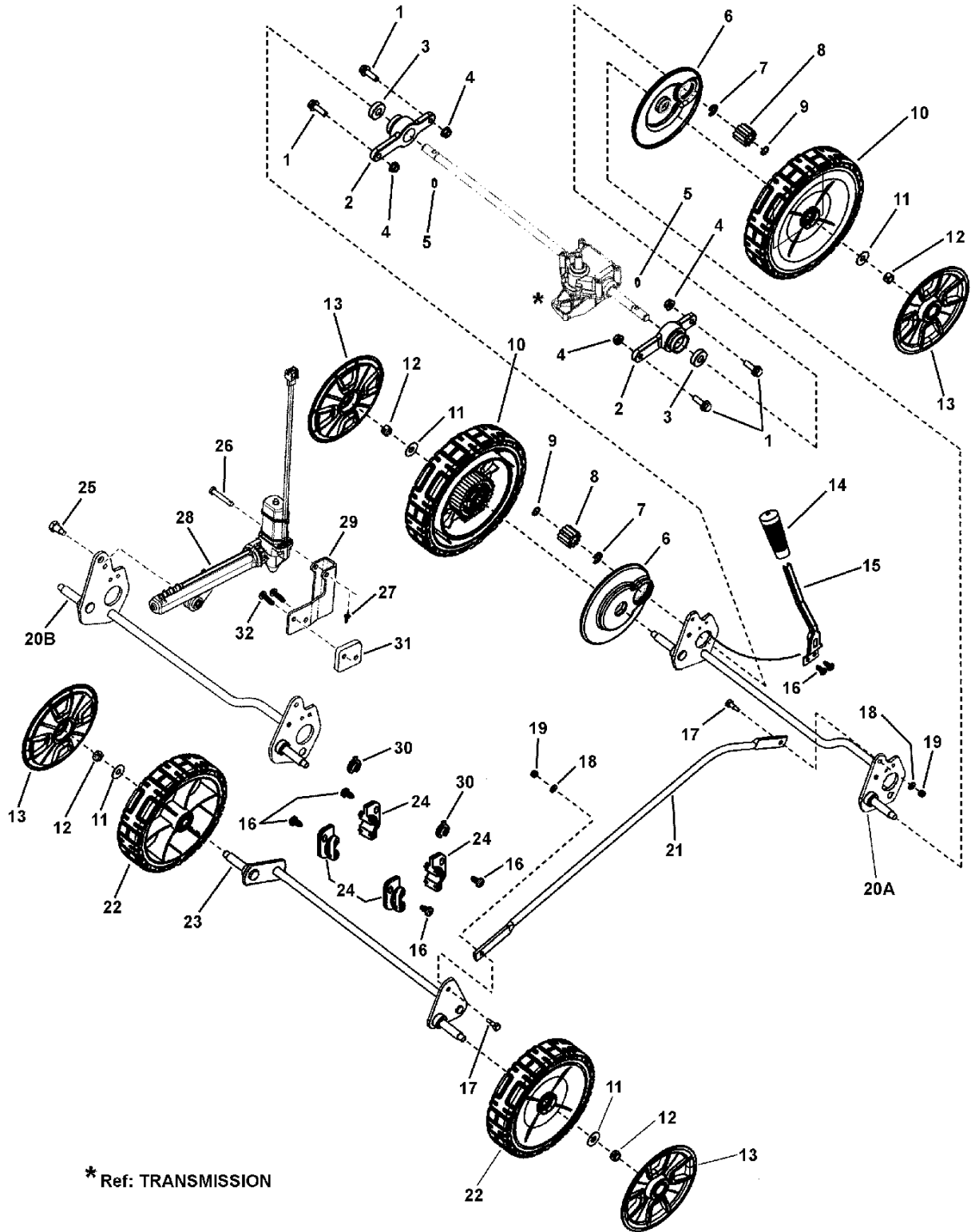

Item	Part No	Qty	Description
1	7091591	4	BOLT, 5/16-18 x 1" Hex Flange Lock, GR 5, YZ
2	7103290	2	HOLDER, Bearing, Rear Wheel Drive
3	7078243	2	BALL BEARING, Axle
4	1931277	4	NUT, 5/16-18 Hex Flange Lock, GR 5, YZ (Was 7091601)
5	7100861	2	PIN, Axle
6	7101367	2	SHIELD, Dust, 21" WBM, RD
7	7014341	2	RETAINING RING, 3.92 EXT. (Waldes #5133-50 or equiv.)
8	7100820	2	GEAR, Pinion
9	7027999	2	RETAINING RING, .452-.463 ID (Waldes #5100-50 or equiv.)
10	7500539	2	ASSEMBLY, Wheel, 9 x 2, Snapper Tread w/Ext Gear (includes ball bearings #7101380, gear #7100914, & screws #7091196)
11	722604	4	WASHER, 1" OD x .387 ID, Flat
12	7091585	4	NUT, 3/8-16 Hex Center Lock, YZ
13	7102507	4	HUBCAP, 8" & 9" Wheel Spoked-Snapper Cool Gray
14	724887	1	GRIP, Height-Of-Cut
15	7103289	1	LEVER, Spring, Height-Of-Cut
16	7900067	6	SCREW, 1/4-20 x .550 Pan Head Self-Tap (Torx)
17	7101774	2	SHOULDER BOLT, #10-24
18	7091552	2	WASHER, .219 x .500 x .049 Flat
19	7091290	2	NUT, #10-24 UNC-2B Nyloc
20A	7400259	1	WELDMENT, Rear Crossbar, RWD (used on 7800722 & 7800580 models)
20B	7400290	1	WELDMENT, Rear Crossbar, EHOC, RWD (used on 7800752 & 7800782 models)
21	7103306D	1	ROD, Lifter Link, WBM
22	7500540	2	ASSEMBLY, Wheel, 8 x 2 Idle, Snapper Tread Snapper Charcoal Gray (includes two ball bearings, p/n 7101380)
23	7400306	1	WELDMENT, Front Axle
24	7104518	4	BUSHING, Bearing, RWD
25	7900078	1	SHOULDER BOLT, 3/8 Dia. (1/4-20 threads) (used on 7800752 & 7800782 models)
26	7014304	1	PIN, 1/4 x 1-5/8" Clevis (used on 7800752 & 7800782 models)
27	7023590	1	PIN, 1/4" Cotter, Self-Locking (used on 7800752 & 7800782 models)
28	7104245BH	1	MOTOR, Electric, HOC (used on 7800752 & 7800782 models)
29	7301178	1	BRACKET, Electric Motor (used on 7800752 & 7800782 models)
30	7104525	2	SPACER, Shaft, 1/2"
31	7301212	1	PLATE, Spacer, EHOC
32	1960671	2	SCREW, 1/4-20 x 3/4" Pan Head Self-Tap (Torx)

Footnotes:

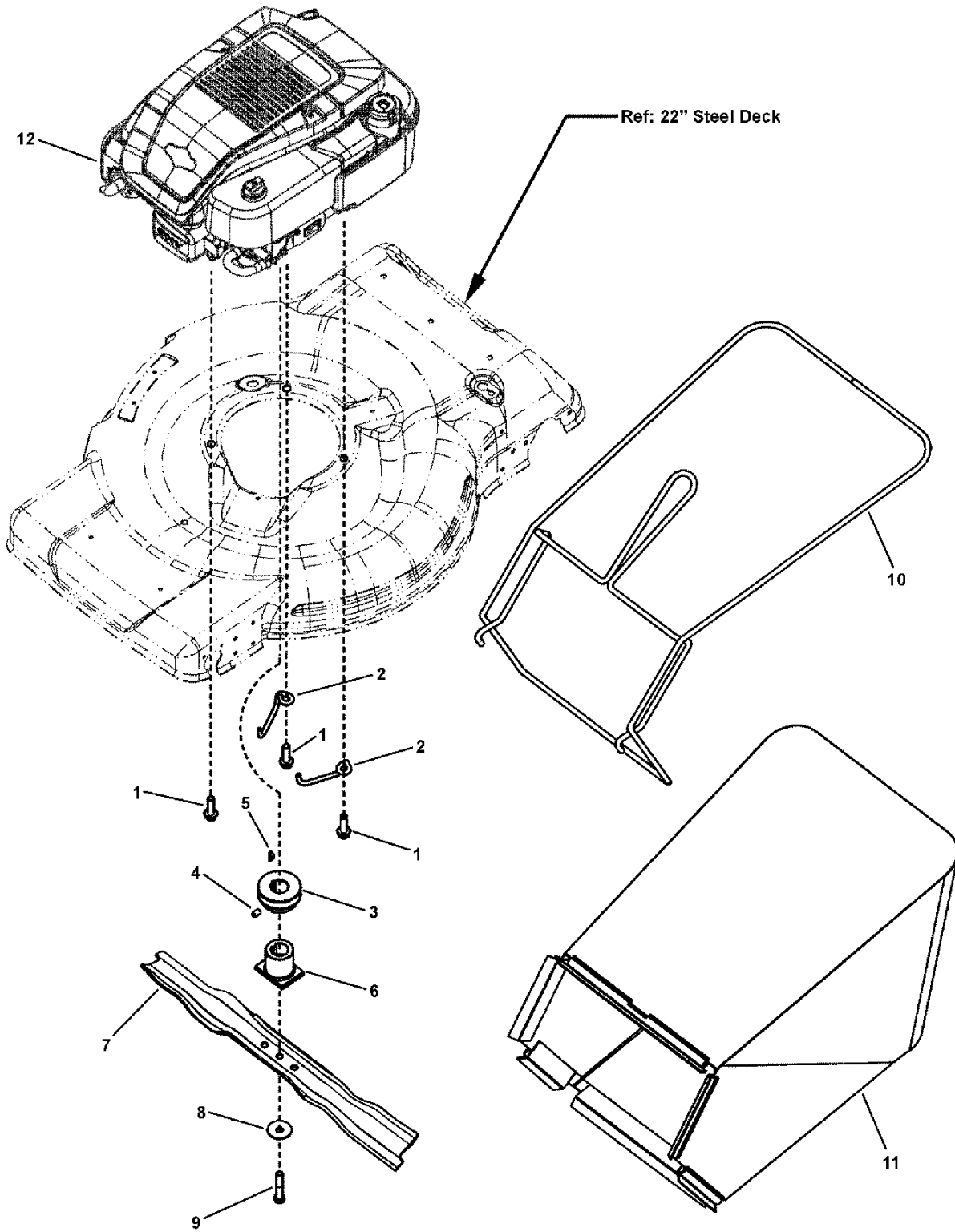

Engine, Blade & Grass Bag Group

Item	Part No	Qty	Description
1	7900072	3	SCREW, 3/8-16 x 1-1/4" Hex Washer Self-Tap
2	7103517	2	BELT GUIDE, Engine
3	7100437	1	PULLEY, Engine
4	7092086	1	SET SCREW, 5/16-18 x 1/2" Hex Recess
5	7091214	1	KEY, #HP-506 Hi-Pro
6	7101414	1	BLADE HUB, 21" WBM, Rear Drive, 2 Position
7	7103288BZ	1	BLADE, Wave, Steel Deck
8	7012063	1	WASHER, Cone
9	7090167	1	SCREW, 3/8-24 x 2" Hex Head Cap, GR 5
10	7103305A	1	BAG FRAME, Rear Discharge (weldment)
11	7103375	1	GRASS BAG, 22" Rear Discharge
12	12S907-0141-B1	1	* ENGINE, W-14, 875 Series, MY Mower (used on 7800580 & 7800752 models)
12	121S07-2116-F1	1	* ENGINE, W-14, 875 Series, MY Mower FC/CAL (used on 7800696 & 7800782 models)

Footnotes:

NOTE: * Purchase engine parts from engine manufacturer dealer.

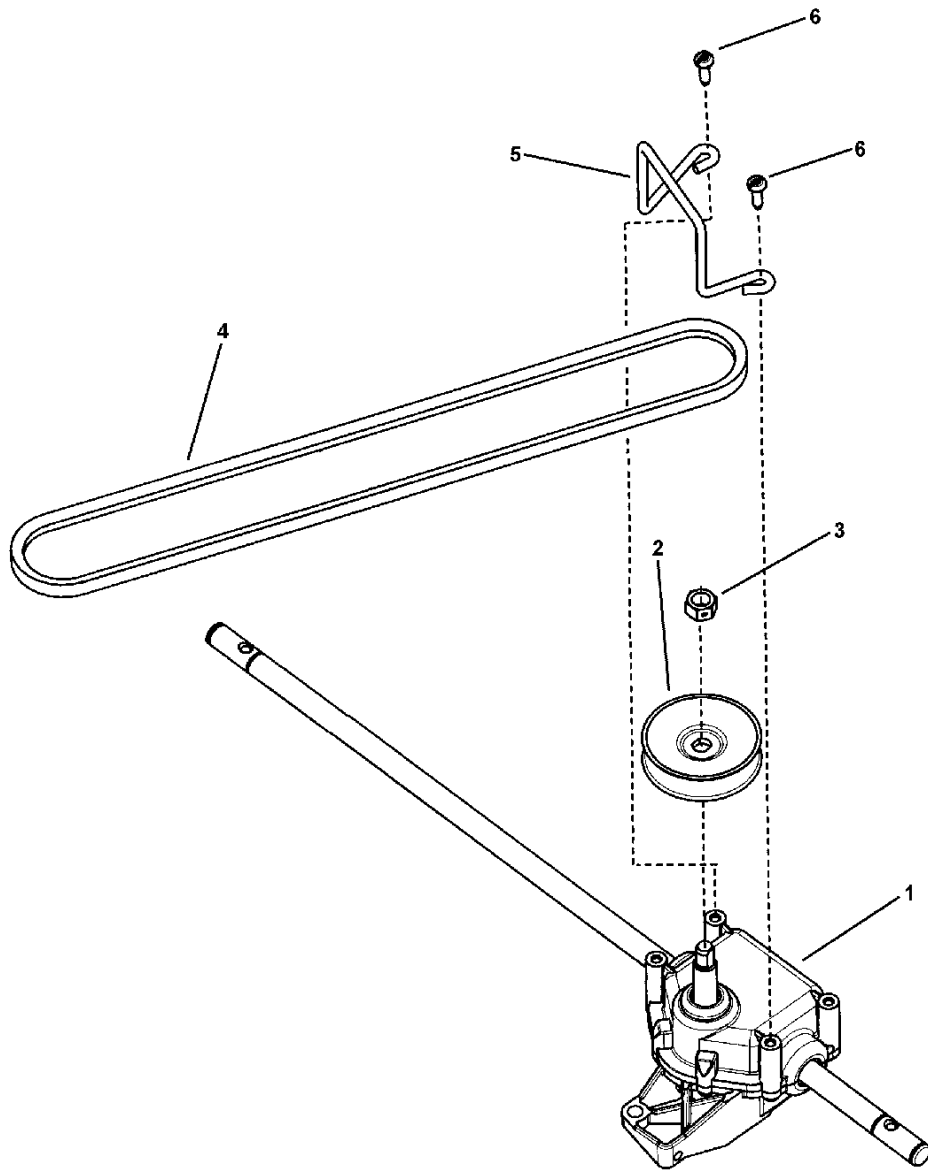

Item	Part No	Qty	Description
1	7103312	1	TRANSMISSION, Variable Speed, Rear Wheel Drive
2	7100240	1	PULLEY, Transmission Variable Speed, LC WBM
3	7091585	1	NUT, 3/8-16 Hex Center Lock, YZ
4	7103364	1	BELT, 3L, Traction Drive, 22" WBM, RWD (3L Section, 33.83" Effective Length)
5	7100863	1	BELT GUIDE, Transmission
6	7091195	2	SCREW, #10-16 x 3/4" Pan Head Self-Tap, Combo

Footnotes:

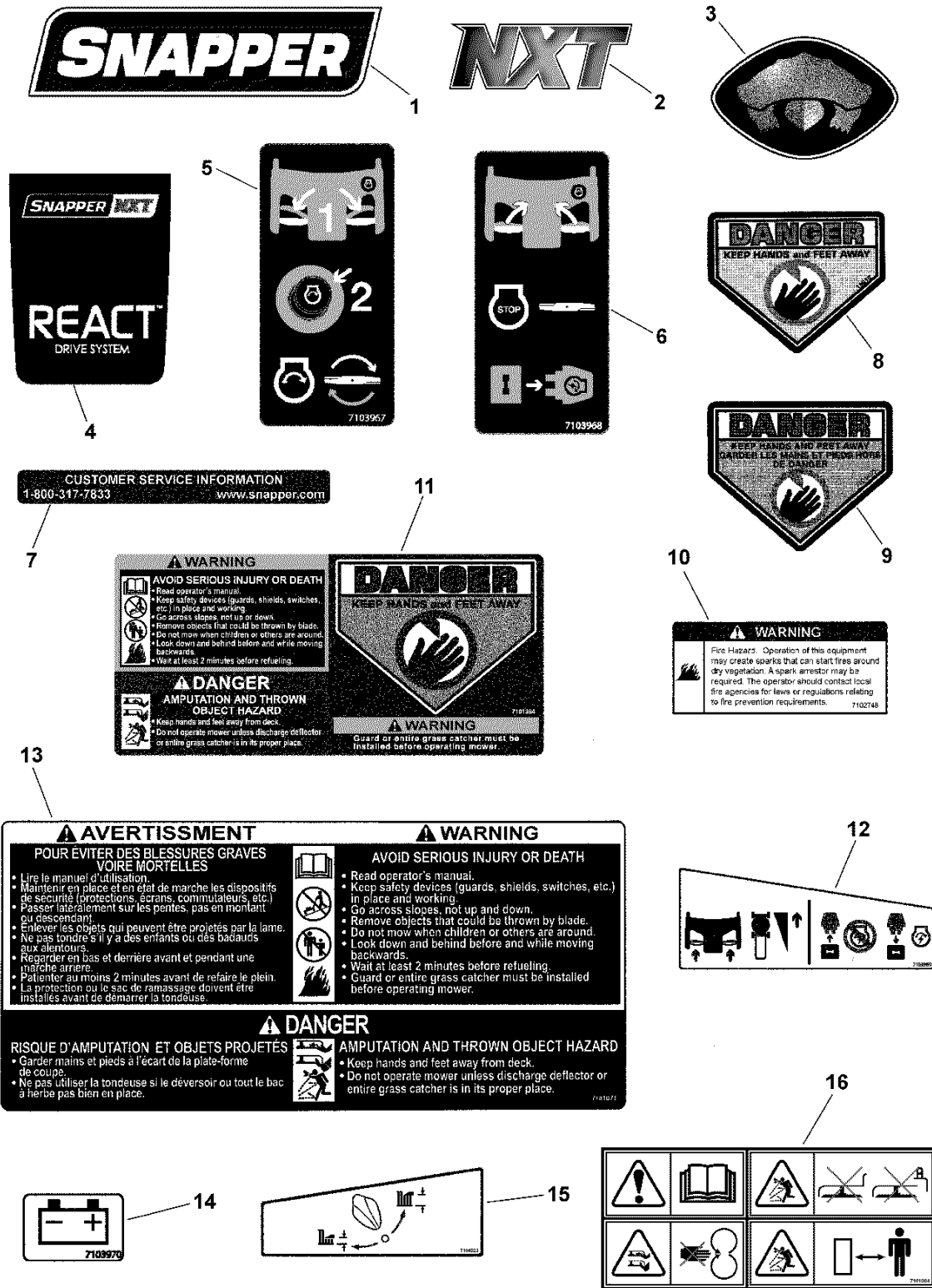

Item	Part No	Qty	Description
1	7103963	1	DECAL, Front Shroud, Snapper Logo
2	7103964	1	DECAL, Front Shroud, NXT Logo
3	7103965	1	DECAL, Handle, Domed Turtle
4	7103966	1	DECAL, Handle, React Drive
5	7103967	1	DECAL, Start NXT
6	7103968	1	DECAL, Stop NXT
7	7102275	1	DECAL, Customer Service, MY08, Snapper
8	7013010	1	DECAL, Danger, Cut Finger
9	7101495	1	DECAL, CPSC, French/English
10	7102746	1	DECAL, Arrestor, Spark
11	7101394	1	DECAL, Warning, Rear Discharge Door
12	7103969	1	DECAL, Key Switch
13	7101671	1	DECAL, French/English, WB Safety
14	7103970	1	DECAL, Battery
15	7104623	1	DECAL, Electric Height-of-Cut
16	7101084	1	DECAL, Warning, Euro, Multi-Panel

Footnotes:

Hardware Identification & Torque Specifications

Torque Specification Chart								
FOR STANDARD METRIC MACHINE HARDWARE (Tolerance ± 20%)								
Property Class	5.6		8.8		10.9		12.9	
	Class 5.6		Class 8.8		Class 10.9		Class 12.9	
Size Of Hardware	in/lbs		in/lbs		in/lbs		in/lbs	
	ft/lbs	Nm.	ft/lbs	Nm.	ft/lbs	Nm.	ft/lbs	Nm.
M3	5.88	.56	13.44	1.28	19.2	1.80	22.92	2.15
M4	13.44	1.28	30.72	2.90	43.44	4.10	52.56	4.95
M5	26.4	2.50	60.96	5.75	5.97	8.10	7.15	9.7
M6	44.64	4.3	7.3	9.9	10.3	14	12.1	16.5
M7	5.2	7.1	12.1	16.5	16.9	23	19.9	27
M8	7.7	10.5	17.7	24	25	34	29	40
M10	15	21	35	48	50	67	59	81
M12	26	36	61	83	86.2	117	103	140
M14	42	58	101	132	136	185	162	220
M16	64	88	147	200	210	285	250	340
M18	89	121	202	275	287	390	346	470
M20	126	171	290	390	405	550	486	660
M22	169	230	390	530	559	745	656	890
M24	217	295	497	375	708	960	840	1140
M27	320	435	733	995	1032	1400	1239	1680
M30	435	590	995	1350	1401	1900	1681	2280
M33	590	800	1349	1830	1902	2580	2278	3090
M36	759	1030	1740	2360	2441	3310	2935	3980
M39	988	1340	2249	3050	3163	4290	3798	5150

Torque Specification Chart						
FOR STANDARD MACHINE HARDWARE (Tolerance ± 20%)						
Hardware Grade	No Marks		SAE Grade 5		SAE Grade 8	
	SAE Grade 2		SAE Grade 5		SAE Grade 8	
Size Of Hardware	in/lbs		in/lbs		in/lbs	
	ft/lbs	Nm.	ft/lbs	Nm.	ft/lbs	Nm.
8-32	19	2.1	30	3.4	41	4.6
8-36	20	2.3	31	3.5	43	4.9
10-24	27	3.1	43	4.9	60	6.8
10-32	31	3.5	49	5.5	68	7.7
1/4-20	66	7.6	8	10.9	12	16.3
1/4-28	76	8.6	10	13.6	14	19.0
5/16-18	11	15.0	17	23.1	25	34.0
5/16-24	12	16.3	19	25.8	29	34.0
3/8-16	20	27.2	30	40.8	45	61.2
3/8-24	23	31.3	35	47.6	50	68.0
7/16-14	30	40.8	50	68.0	70	95.2
7/16-20	35	47.6	55	74.8	80	108.8
1/2-13	50	68.0	75	102.0	110	149.6
1/2-20	55	74.8	90	122.4	120	163.2
9/16-12	65	88.4	110	149.6	150	204.0
9/16-18	75	102.0	120	163.2	170	231.2
5/8-11	90	122.4	150	204.0	220	299.2
5/8-18	100	136	180	244.8	240	326.4
3/4-10	160	217.6	260	353.6	386	525.0
3/4-16	180	244.8	300	408.0	420	571.2
7/8-9	140	190.4	400	544.0	600	816.0
7/8-14	155	210.8	440	598.4	660	897.6
1-8	220	299.2	580	788.8	900	1,244.0
1-12	240	326.4	640	870.4	1,000	1,360.0

The guides and ruler furnished below are designed to help you select the appropriate hardware.

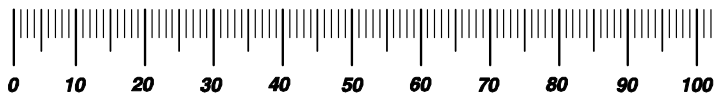

Nut, M8

Thread Diameter (mm)
Inside Diameter (in) Threads per inch

Nut, 1/2-16

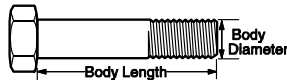

Screw, M8- 1.25 x 25

Thread Diameter (mm) Distance between threads (mm) Body Length (mm)
Body Diameter Threads per inch Body Length (in)

Screw, 1/2- 16 x 2



Standard Hardware Sizing

When a washer or nut is identified as 1/2" (M8), this is the *Nominal size*, meaning the *inside diameter* is 1/2 inch (8mm metric thread diameter); if a second number is present it represents the *threads per inch* (distance between threads).

When bolt or capscrew is identified as 1/2 - 16 x 2" (M8 - 1.25 x 50), this means the *Nominal size*, or body diameter is 1/2 inch (8mm metric thread diameter), the second number, 16, represents the *threads per inch*, (1.25 thread diameter). The final number is the body length of the bolt or screw, 2 inches (50mm).

NOTES

- These torque values are to be used for all hardware excluding: locknuts, self-tapping screws, thread forming screws, sheet metal screws and socket head setscrews.
- Recommended seating torque values for locknuts:
 - for prevailing torque locknuts - use 65% of grade5 torques.
 - for flange whizlock nuts and screws - use 135% of grade 5 torques.
- Unless otherwise noted on assembly drawings, all torque values must meet this specification.

Common Hardware Types

Hex Head Capscrew



Washer



Carriage Bolt



Lockwasher

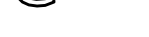

Hex Nut



Wrench & Fastener Size Guide

1/4" Bolt or Nut Wrench—7/16"	5/16" Bolt or Nut Wrench—1/2"	3/8" Bolt or Nut Wrench—9/16"	7/16" Bolt or Nut Wrench (Bolt)—5/8" Wrench (Nut)—11/16"	1/2" Bolt or Nut Wrench—3/4"
M6 Bolt or Nut Wrench—10mm	M8 Bolt or Nut Wrench—13mm	M10 Bolt or Nut Wrench—17mm	M12 Bolt or Nut Wrench—19mm	M14 Bolt or Nut Wrench—22mm

Parts Manual for

SNAPPER®

**22" SELF-PROPELLED
ELECTRIC START MOWER
NXT SERIES**

IT IS THE POLICY OF BRIGGS & STRATTON CORP TO IMPROVE ITS PRODUCTS WHENEVER IT IS POSSIBLE AND PRACTICAL TO DO SO. WE RESERVE THE RIGHT TO MAKE CHANGES OR ADD IMPROVEMENTS AT ANY TIME WITHOUT INCURRING ANY OBLIGATION TO MAKE SUCH CHANGES ON PRODUCTS

Briggs & Stratton Yard Power Products Group

535 Macon Road
McDonough, GA, 30253 U.S.A.
800-935-2967

www.snapper.com

Copyright © 2011 Briggs & Stratton Corporation
Milwaukee, WI USA. All Rights Reserved

Manual No. 7104329

Revision: C 2/9/2011