

TECHNICAL INFORMATION Number: Y2019-675(2/2)

Cushion	 <p>V420-005260 : 1 pc</p>	 <p>V420-005260(Unchanged) : 3 pcs</p>
Cushion V420-005260 (2 pcs) can be used on the unit before this change.		

Adding 2 pcs of cushions on cleaner case

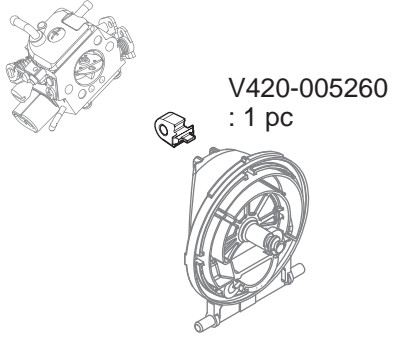
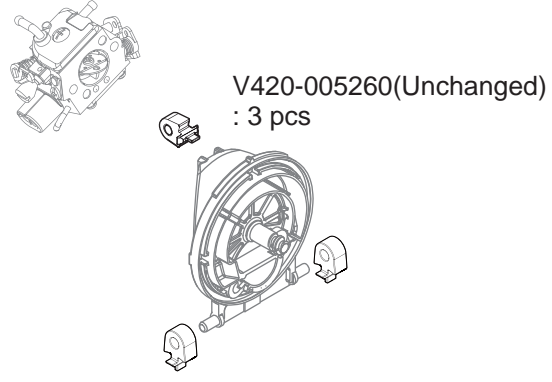
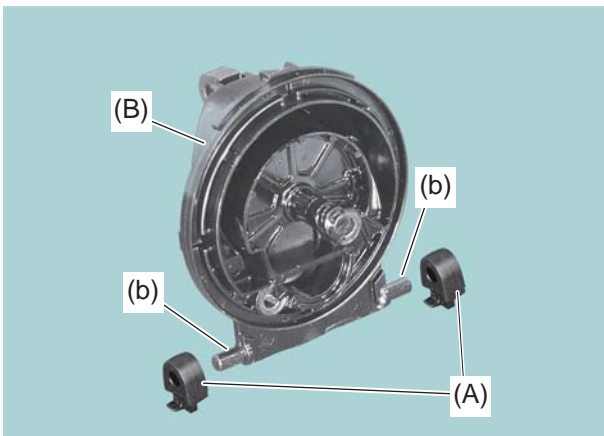

1. Pass 2 cushions V420-005260 (A) through 2 ribs (b) of cleaner case (B).

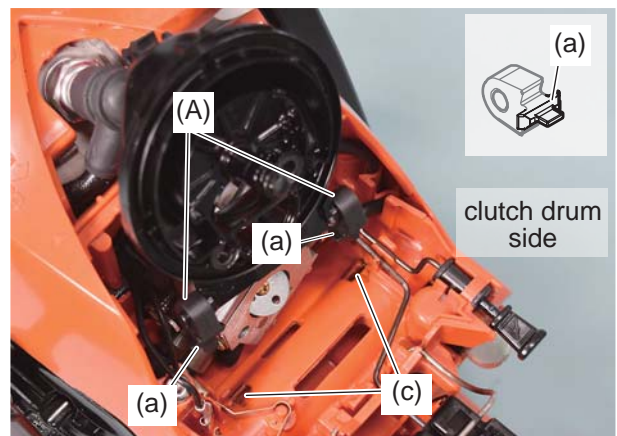

2. Install rib (a) of each cushion (A) in engine cover hole (c).

NOTE: At first, install rib (a) in engine cover hole (c) from clutch drum side to assemble easily.



3. Use flat head screwdriver (D) when it is difficult to install rib (a) of each cushion.

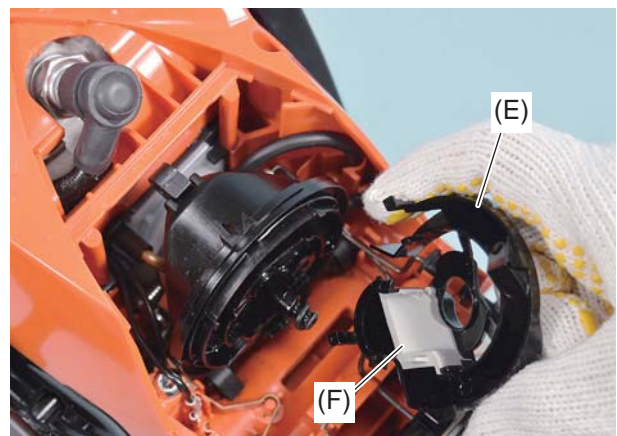

4. Assemble big air duct (E) with small air duct (F). Then tighten 2 torx bolts.