



Parts Manual

Mfg. No: 2691297-01
SRD200, 7220 Rear Discharge Lawn

1690163 - Chains, Tire Pr. (20 X 8).....

1696092 - Dozer Blade, 42".....

885644 - Grass Mulcher Kit, 96cm Rear Discharge Lawn Tractor.....

885654 - Rear Deflector, Rear Discharge Lawn Tractor.....

1696352 - Rear Wheel Weight, 32 Lbs.....

1696423-00 - Snowthrower, Single Stage, 42".....

885638 - Adapter Kit, Dozer Blade.....

885634 - Snowthrower Kit, Rear Discharge Lawn Tractor.....

Not For
Reproduction

Model Components	Page
96cm Mower Deck - Clutch Group.....	4
96cm Mower Deck - Housing & Blades Group.....	6
96cm Mower Deck - Support Group.....	8
Backplate Group.....	10
Bystander Group.....	12
Collector Group.....	14
Controls Group.....	16
Decals Group.....	18
Electrical Group.....	20
Engine Group.....	24
Frame Group.....	26
Front Axle Group.....	30
Hood, Grille & Dash Group.....	32
Lift Group (885450).....	34
Mulch Plug Group.....	36
Seat Deck & Fuel Tank Group.....	38
Transmission Group - Hydro Gear.....	40
Transmission SERVICE PARTS - Hydro Gear 324-0610 (885528).....	42
Wheel & Tire Group (885914).....	48
Torque Specification Chart.....	50

Not For
Reproduction

96cm Mower Deck - Clutch Group

Note: Unless noted otherwise, use the standard torque specifications

Mfg. No: 2691297-01

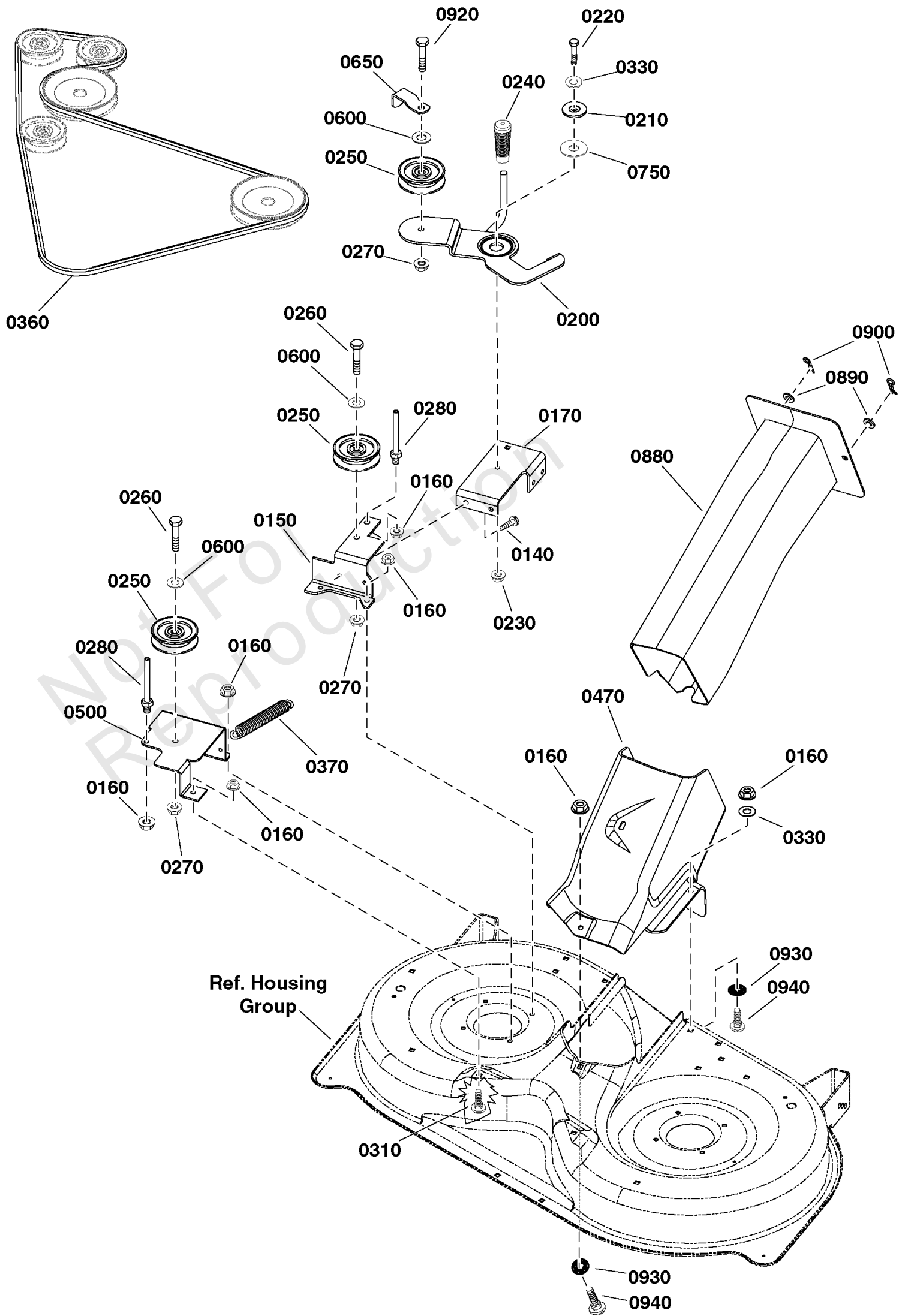

96cm Mower Deck - Clutch Group

REF NO	PART NO	QTY	DESCRIPTION
0140	703228	4	SCREW, Washer Head Taptite, 5/16-18 X 3/4
0150	1758773BMYP	1	BRACKET, Idler, RH
0160	703409	10	NUT, Serrated Lock Flange, 5/16-18
0170	885516AYP	1	SUPPORT, Idler Arm
0200	885559AYP	1	DECK IDLER ASSEMBLY
0210	1727935SM	1	SPACER, Pivot, 0.330ID 1.76OD
0220	703585	1	CAPSCREW, Hex Head, 5/16-18 x 1
0230	704067	1	NUT, Hex Flange, 5/16-18
0240	092697MA	1	GRIP
0250	885482YP	3	IDLER, Pulley
0260	703589	2	CAPSCREW, Hex Head, 3/8-16 x 2, G5
0270	703333	3	NUT, Hex Flange, Whiz Lock, 3/8-16
0280	885534YP	2	BELT GUIDE
0310	703185	3	BOLT, Carriage, 5/16-18 X 3/4
0330	1919326SM	1	WASHER, 5/16
0330	1919326SM	4	WASHER, 5/16
0360	1758762YP	1	BELT, Deck
0370	1715435SM	1	SPRING, Extension
0470	885460YP	1	DECK, Center Cap
0500	885556AYP	1	BRACKET, Idler, Fixed
0600	704128	3	WASHER, Flat, 3/8
0650	1677135SM	1	GUARD, Spring
0750	885675YP	1	SHIM
0880	885461YP	1	CHUTE
0890	703853	2	WASHER, 1/2
0900	703300	2	PIN, Hair, 3/32 x 1 5/8
0920	703872	1	CAPSCREW, Hex Head, 3/8-16 X 2 1/4
0930	703297	6	RETAINER, 5/16 X 5/8
0940	704065	3	BOLT, Carriage, Short Neck, 5/16-18 X 7/8

96cm Mower Deck - Housing & Blades Group

REF NO	PART NO	QTY	DESCRIPTION
0010	1735571YP	1	ARBOR ASSEMBLY
0010-10	1735573YP	1	HOUSING, Spindle
0010-20	1735399YP	2	BEARING, Ball, 20mm
0010-30	1735326YP	1	SHAFT, Spindle, LH
0010-50	1735323YP	2	SHIELD, Arbor
0010-60	1735328YP	2	SPACER, Bearing
0010-70	1960766YP	2	RING, Self Locking
0020	885551YP	1	ARBOR ASSEMBLY
0020-10	885420YP	1	SHAFT, Spindle, RH (LH Thread)
0020-20	1735323YP	2	SHIELD, Arbor
0020-30	1735328YP	2	SPACER, Bearing
0020-40	1735399YP	2	BEARING, Ball, 20mm
0020-50	1735573YP	1	HOUSING, Spindle
0020-60	1960766YP	2	RING, Self Locking
0030	1930600SM	8	CAPSCREW, Hex Washer Head, Taptite, 5/16-18 x 1-1/2
0040	1750338YP	2	SPACER, Mower Drive
0050	1758750YP	2	PULLEY
0060	1656916SM	4	WASHER, Spring, 0.475ID x 1-3/4 OD
0070	1926110SM	1	CAPSCREW, Hex Head, 7/16-14 x 2-3/4. G5
0080	703846	1	CAPSCREW, Socket Head, 7/16-14 x 2-3/4, LH
0090	1758511BMYP	1	BLADE, RH
0100	703845	1	CAPSCREW, Socket Head, 7/16-14 x 1, LH
0110	1758512BMYP	1	BLADE, LH
0120	1920676SM	1	CAPSCREW, Hex Head, 7/16-14 X 1
0130	1756247YP	2	ADAPTER, Washout Port
0140	703228	2	SCREW, Washer Head Taptite, 5/16-18 X 3/4
0160	703409	9	NUT, Serrated Lock Flange, 5/16-18
0590	1704314	2	FITTING, Grease
0710	709692	1	KIT, Mower Deck, 96cm, Crow Black
0910	7046780SM	4	PLUG, Hole, .44" OD
0920	1756246YP	1	CONNECTOR, Washout Port

96cm Mower Deck - Support Group

Note: Unless noted otherwise, use the standard torque specifications

Mfg. No: 2691297-01

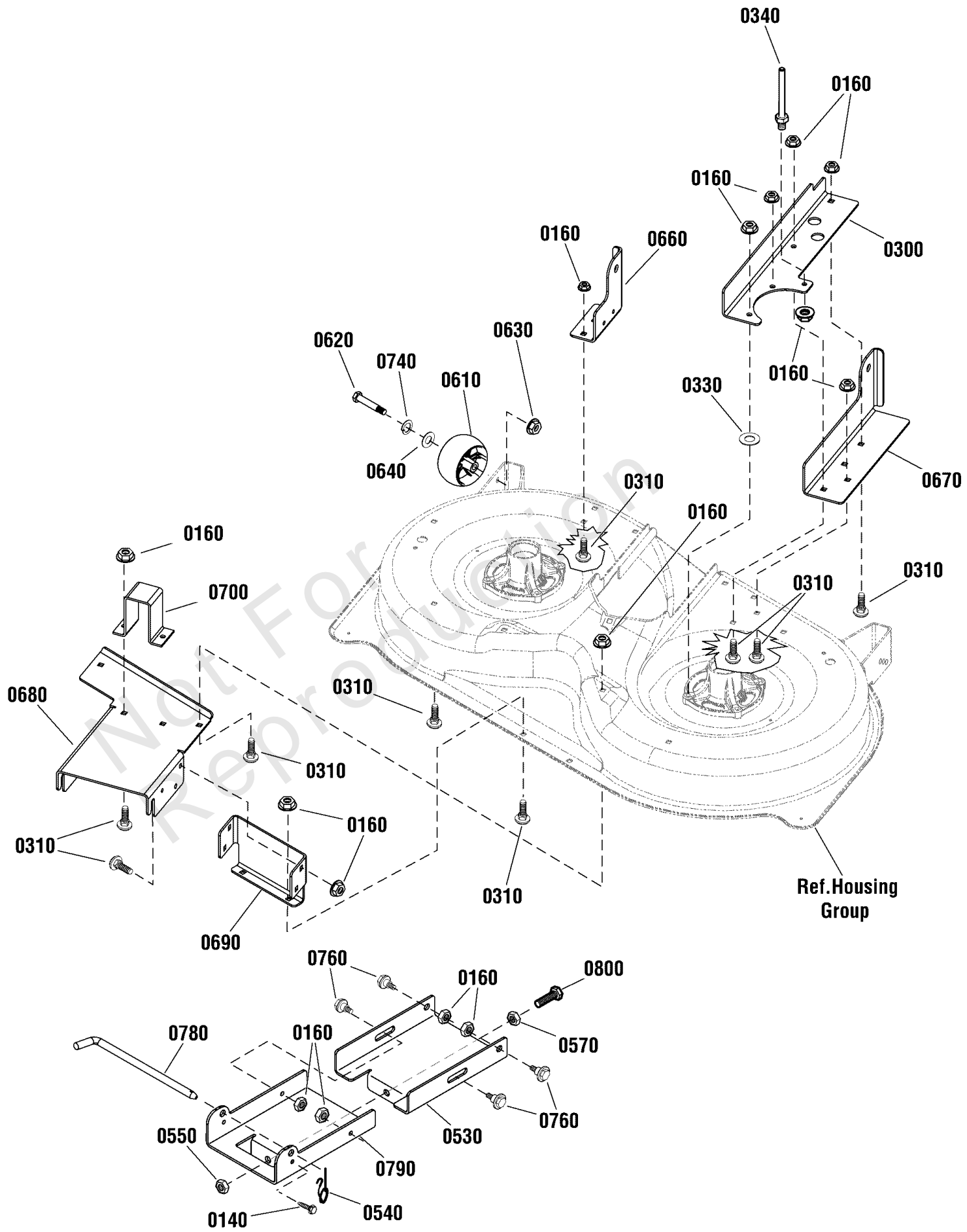

96cm Mower Deck - Support Group

REF NO	PART NO	QTY	DESCRIPTION
0140	703228	2	SCREW, Washer Head Taptite, 5/16-18 X 3/4
0160	703409	22	NUT, Serrated Lock Flange, 5/16-18
0300	1758761BMYP	1	BRACKET, Rear Lift, LH
0310	703185	15	BOLT, Carriage, 5/16-18 X 3/4
0330	1919326SM	2	WASHER, 5/16
0340	1401105MA	1	BELT GUIDE, Long
0530	885734BMYP	1	BRACKET, Front Connector
0540	703852	1	PIN, Retainer, 5/16 x 3/8
0550	1960379SM	1	NUT, Hex Lock, 1/2-13
0570	1913744SM	1	NUT, Hex Jam, 1/2-13
0610	1714760SM	2	GAUGE WHEEL
0620	2108765SM	2	BOLT, 3/8-16 x 2-3/4
0630	703158	2	NUT, Hex Flange, 3/8-16
0640	703853	2	WASHER, 1/2
0660	885462AYP	1	BRACKET, Deck, Rear
0670	885463AYP	1	BRACKET, Rear Lift, LH
0680	885738BMYP	1	SUPPORT, Deck Front
0690	885740BMYP	1	BRACKET, Front Support
0700	885519AYP	1	BRACKET, Front Upstop
0740	0020X3MA	2	WASHER, Spring, .30" ID
0760	1732426SM	4	BOLT, Shoulder, 5/16-18 x 13/16, 1/2" Thread Length
0780	1731414SM	1	ROD, Latch
0790	885699BMYP	1	BRACKET, Front Hanger
0800	885710YP	1	BOLT, 1/2 x 3

Backplate Group

Note: Unless noted otherwise, use the standard torque specifications

Mfg. No: 2691297-01

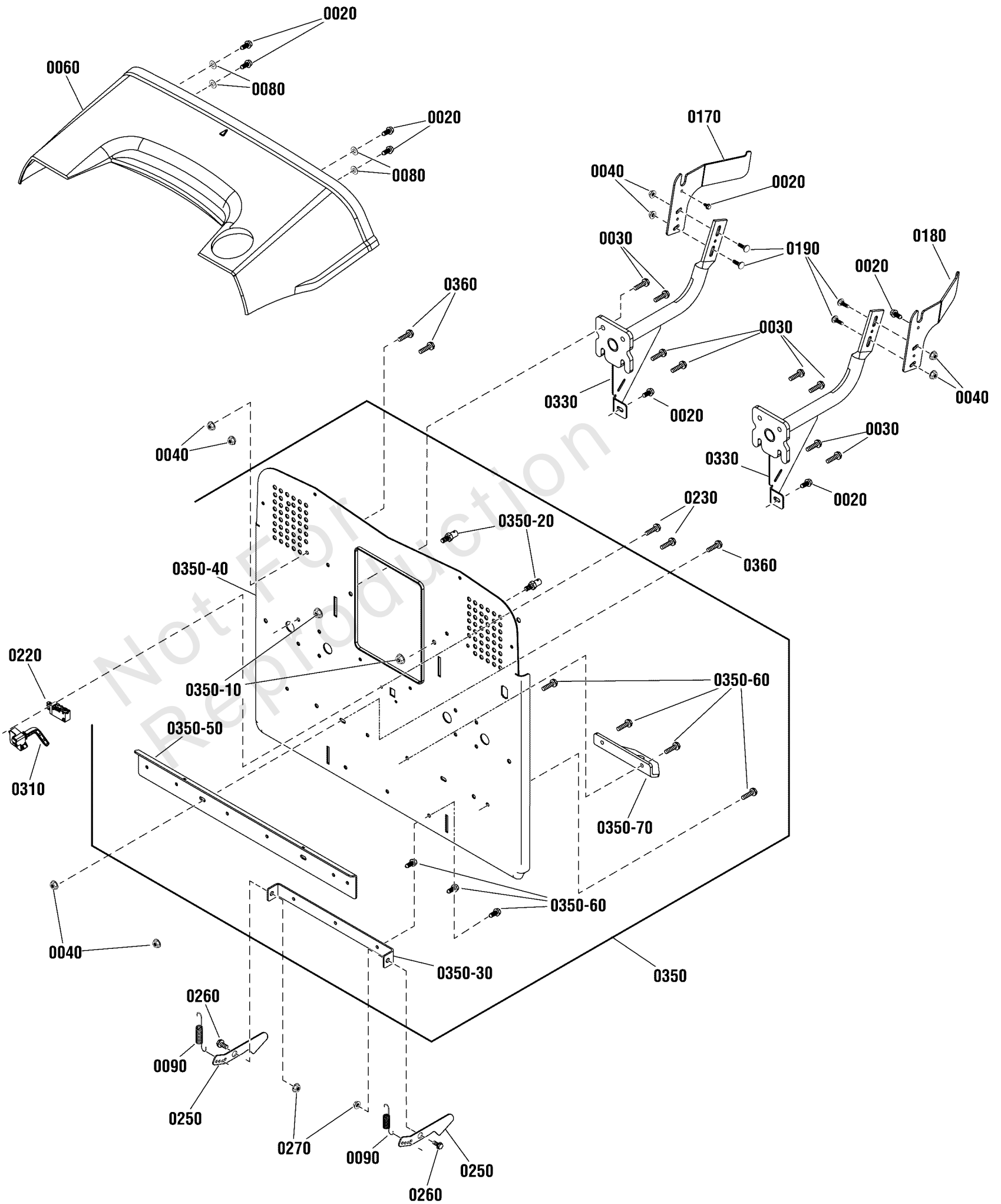

Backplate Group

REF NO	PART NO	QTY	DESCRIPTION
0020	703228	8	SCREW, Washer Head Taptite, 5/16-18 X 3/4
0030	703167	8	SCREW, Taptite, 5/16-18 x 1-1/4
0040	703409	10	NUT, Serrated Lock Flange, 5/16-18
0060	1758498YP	1	TRANSITION PIECE
0080	1919326SM	4	WASHER, 5/16
0090	165X75MA	2	SPRING, Extension
0170	885853BMYP	1	ROTATION PLATE, RH
0180	885852BMYP	1	ROTATION PLATE, LH
0190	703185	4	BOLT, Carriage, 5/16-18 X 3/4
0220	885573YP	1	SWITCH, Bag Full
0230	880760YP	2	SCREW, Plastite, #10-14 x 7/8
0250	1758530BMYP	2	LATCH
0260	009X39MA	2	BOLT, Shoulder, 3/8-16 x 3/4
0270	703893	2	NUT, Hex, Flange, Two Way Lock, 3/8-16
0310	885618YP	1	COVER, Bag Full Switch
0330	1758925BMYP	2	SUPPORT, Bagger
0350	885893BMYP	1	BACK PLATE ASSEMBLY -(Includes Ref. Nos. 0350-10 thru 0350-70)
0350-10	703893	2	NUT, Hex, Flange, Two Way Lock, 3/8-16
0350-20	704054	2	PIN, Threaded, 3/8-16 x 5/8
0350-30	885497AYP	1	BRACKET, Bagger Latch
0350-40	-----	1	BACK PLATE
0350-50	885891BMYP	1	BRACE, Lower
0350-60	703228	7	SCREW, Washer Head Taptite, 5/16-18 X 3/4
0350-70	885468YP	1	PLATE, Hitch
0350-70	885862YP	1	KIT TOWBRKT
0360	703410	6	BOLT, Serrated Flange, 5/16-18 X 1.0

Bystander Group

Note: Unless noted otherwise, use the standard torque specifications

Mfg. No: 2691297-01

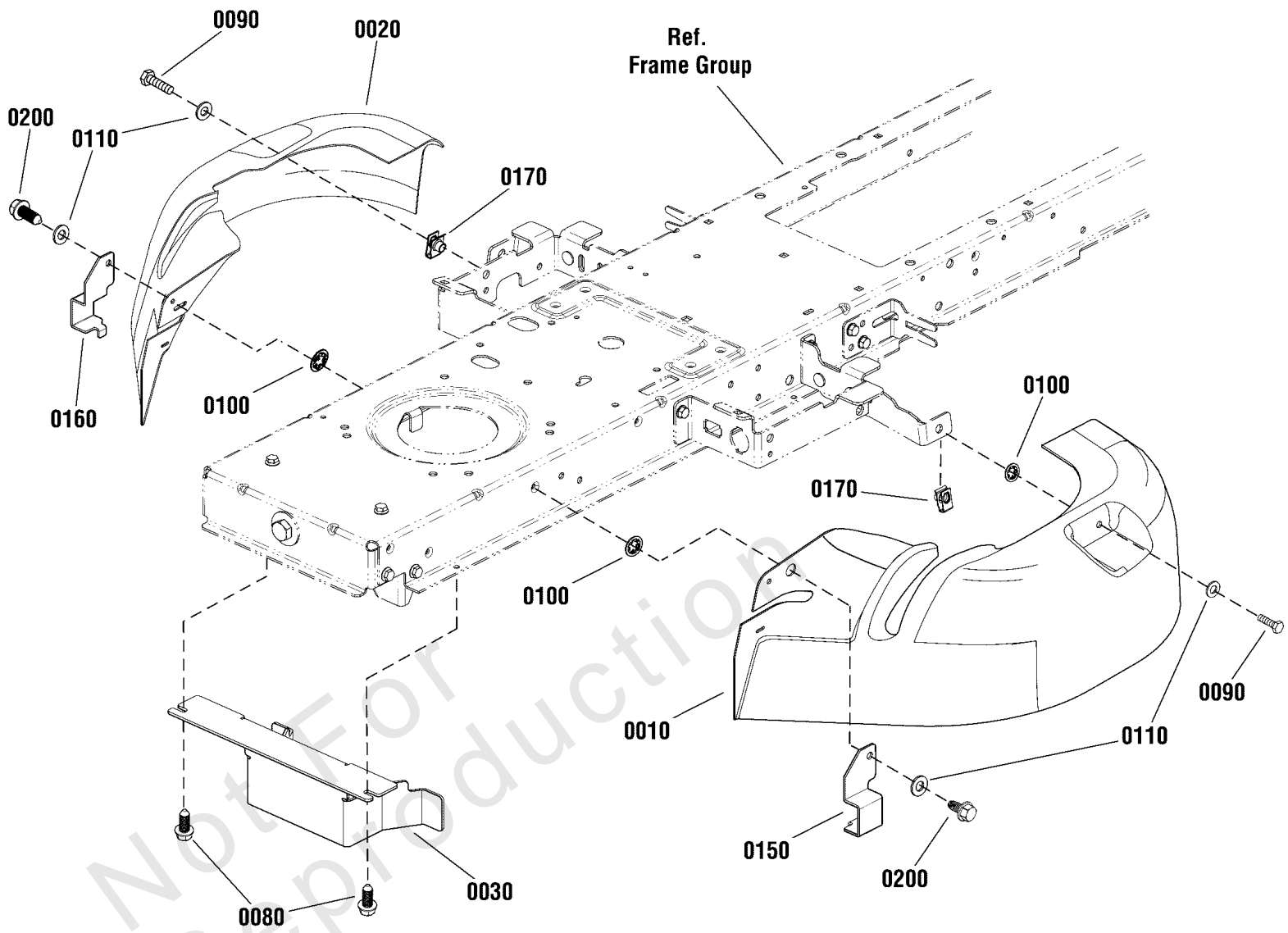

Bystander Group

REF NO	PART NO	QTY	DESCRIPTION
0010	1759737YP	1	GUARD, Front, LH
0020	1759738YP	1	GUARD, Front, RH
0030	171760155CJYP	1	GUARD, Clutch
0080	703228	2	SCREW, Washer Head Taptite, 5/16-18 X 3/4
0090	703408	2	CAPSCREW, 5/16-18 x 7/8
0100	703297	4	RETAINER, 5/16 x 5/8
0110	703350	4	WASHER, Flat, 5/16
0150	1759985BMYP	1	SUPPORT, Guarding, LH
0160	1759989BMYP	1	SUPPORT, Guarding, RH
0170	1935255SM	2	NUT, Speed, Lug Type, 5/16-18
0200	704146	2	SCREW, Hex Taptite, 5/16-18 x 1

Not For
Reproduction

Collector Group

Note: Unless noted otherwise, use the standard torque specifications

Mfg. No: 2691297-01

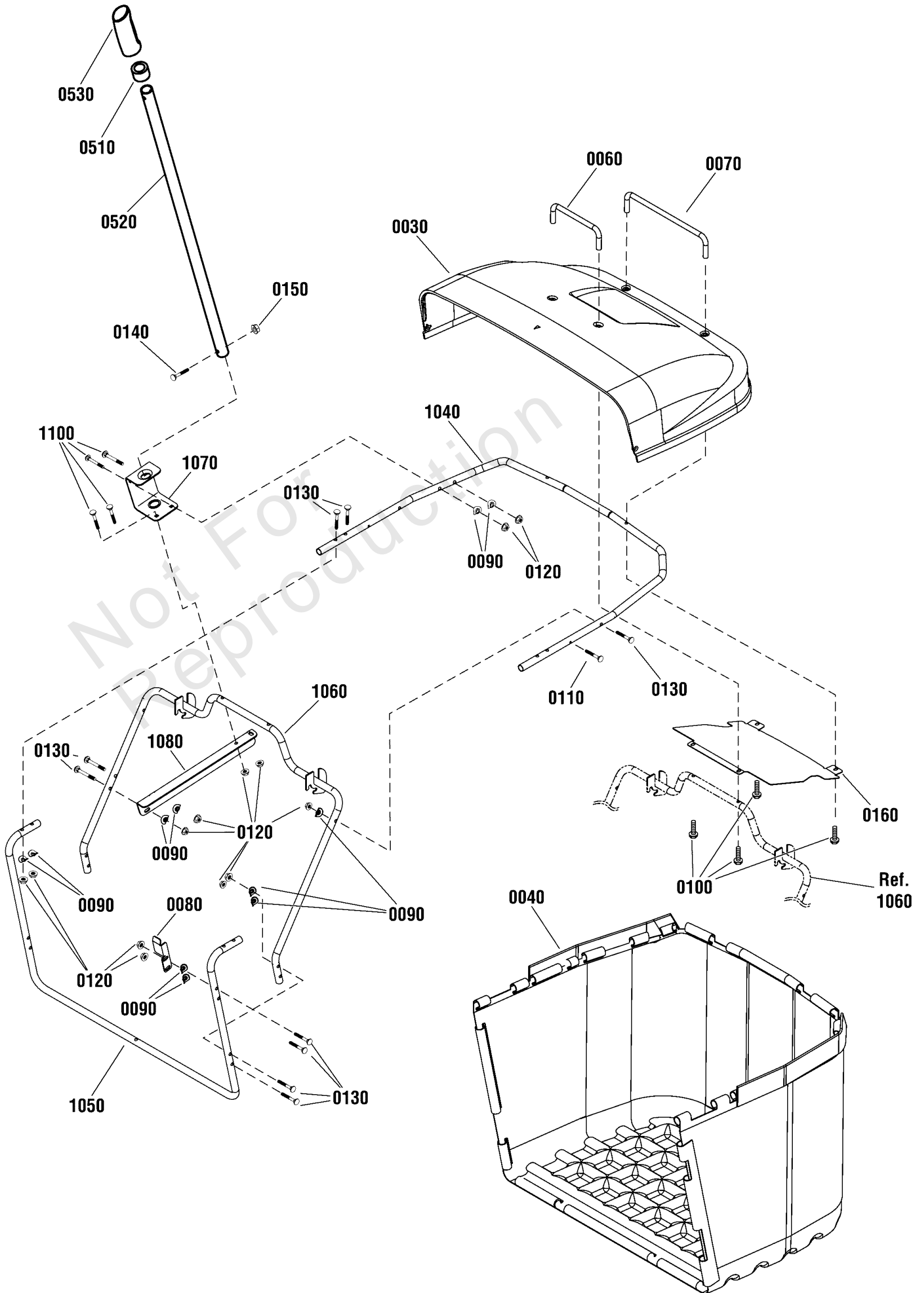

Collector Group

REF NO	PART NO	QTY	DESCRIPTION
0030	1758510YP	1	COVER, Collector
0040	1758532YP	1	BAG, Collector
0060	1758751BMYP	1	HANDLE, Front
0070	885430AYP	1	HANDLE, Back
0080	1758781BMYP	1	SWITCH PLATE
0090	880615YP	16	WASHER
0100	706884	4	SCREW , Hex Washer Head, 1/4-20 x 1-1/2
0110	885564YP	2	SCREW, Torx, 1/4-20
0120	703115	18	NUT, Flange Nylock, 5/16-18
0130	706883	12	SCREW, 5/16-18 x 2
0140	001X94MA	1	BOLT, Hex, 1/4-20 x 1-1/4
0150	015X89MA	1	NUT, Hex Flange, 1/4-20
0160	1758926BMYP	1	SHIELD, Collector
0510	885433YP	1	ADJUSTER, Handle
0520	885518AYP	1	HANDLE, Bagger
0530	1723359SM	1	GRIP
1040	1758255BMYP	1	FRAME, Bagger Support, Upper
1050	1758256BMYP	1	FRAME, Bagger Support, Front
1060	1758329BMYP	1	FRAME, Bagger Support
1070	1758357BMYP	1	SUPPORT, Dump Handle
1080	1758659BMYP	1	BRACKET Dump Handle
1100	703296	4	BOLT, Carriage, 5/16-18 x 1 1/2

Not For
Reproduction

Controls Group

Note: Unless noted otherwise, use the standard torque specifications

Mfg. No: 2691297-01

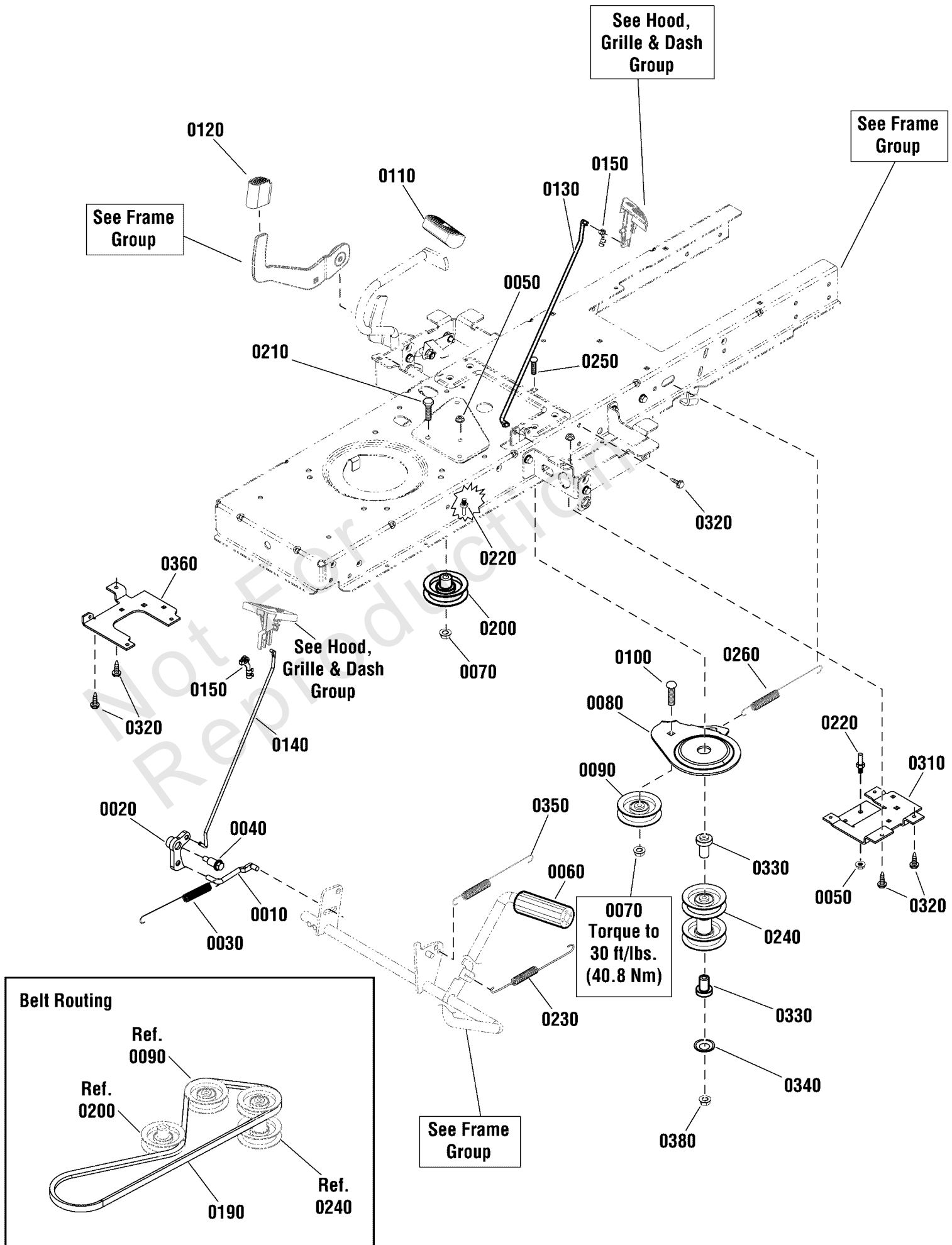

Controls Group

REF NO	PART NO	QTY	DESCRIPTION
0010	1727899SM	1	ROD, Cruise Latch, 2.83"
0020	1727897SM	1	LATCH, Cruise
0030	2159181SM	1	SPRING, Extension 7-3/4
0040	1728976SM	1	BOLT, Shoulder, 5/16-18 x 1-5/8
0050	015X79MA	3	NUT, Flange, 5/16-18, G5
0060	1727261SM	1	PEDAL, Brake Rubber
0070	703158	2	NUT, Hex Flange, ESNA, 3/8-16
0080	885410AYP	1	BRACKET, Idler Front Movable
0090	885645YP	1	PULLEY, 3 OD Plastic
0100	703227	1	BOLT, Carriage, 3/8-16 x 1-1/4
0110	1721675SM	1	PAD, Foot Pedal, Forward
0120	1727259SM	1	PAD, Foot Pedal, Reverse
0130	1727267SM	1	ROD, Parking Brake, 16-3/8"
0140	1738760YP	1	ROD, Cruise Latch, 17"
0150	1728111SM	2	CLIP, Linkage, Black
0190	885895YP	1	BELT, Primary, M/D (47.89" EL, HA Section)
0200	885894YP	1	IDLER, Backside
0210	1921971SM	1	CAPSCREW, Hex Head, 3/8-16 x 1-3/4, G5
0220	885534YP	2	BELT GUIDE
0230	885421YP	1	SPRING, Extension
0240	885426YP	1	PULLEY, Secondary Stack
0250	885577YP	1	BOLT, Carriage, 3/8-16 x 5
0260	1729620SM	1	SPRING, Extension 7-1/2"
0310	885684BMYP	1	BRACKET, Stack Pulley, Left
0320	703228	4	SCREW, Washer Head Taptite, 5/16-18 X 3/4
0330	885575YP	2	SPACER
0340	1931942SM	1	NUT, Push Pal, 3/8
0350	1721995SM	1	SPRING, Extension, 5/8 x 6-5/8
0360	885685BMYP	1	BRACKET, Stack Pulley, Right
0380	015X84MA	1	NUT, Hex Flange, Centerlock, 3/8-16

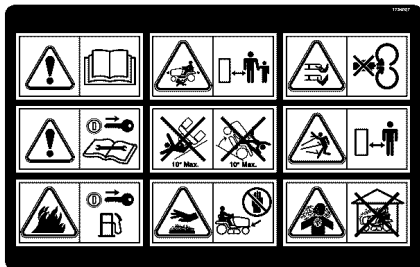
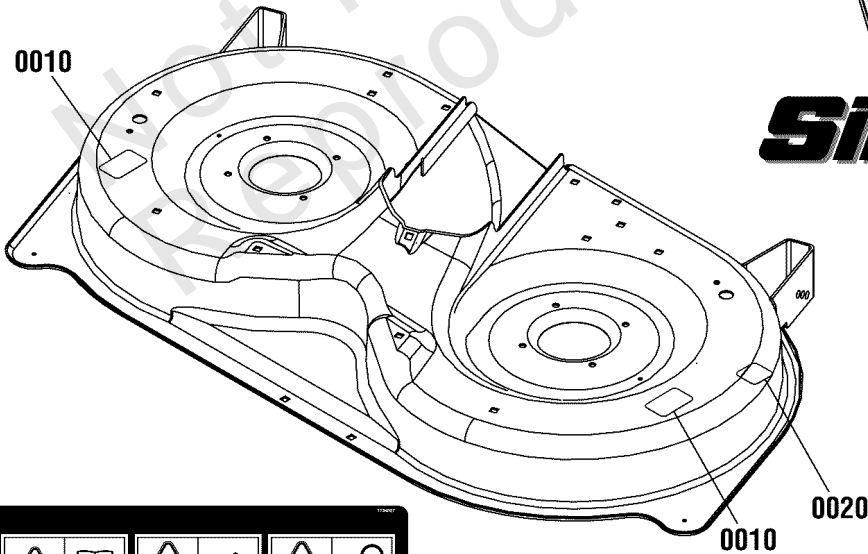
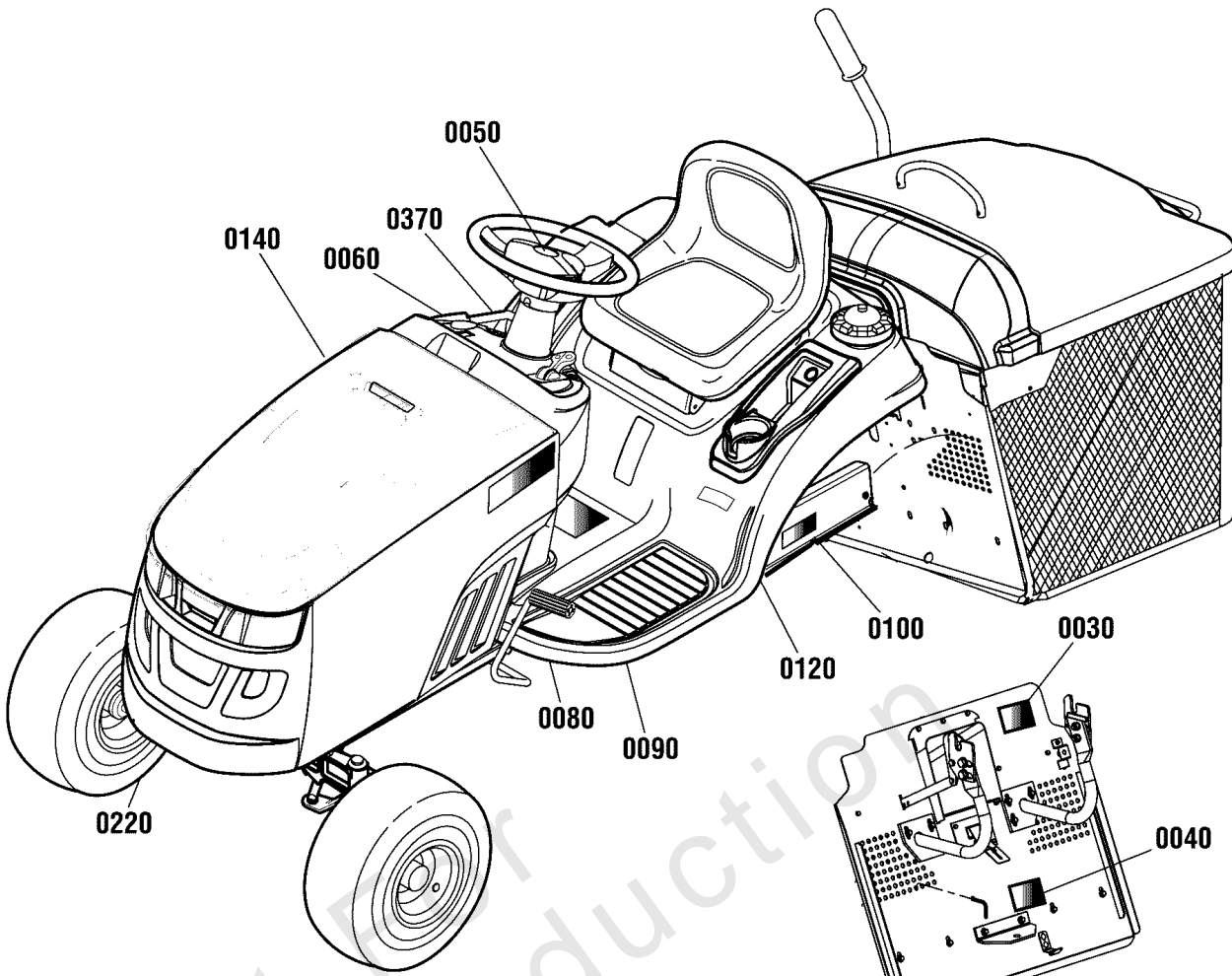

0090



0100

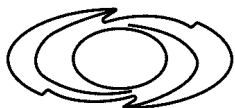

0050

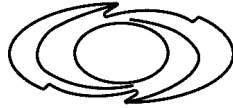

0220

Simplicity

0080,0140



0030



0040

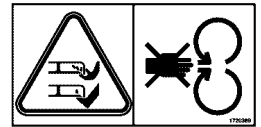

0010

SRD100

0380

SRD200

0370

SRD300

0390

REGENT RD

0120

42"
107cm

0230

38"
96cm

0020



0060

Decals Group

REF NO	PART NO	QTY	DESCRIPTION
0010	1720389SM	2	DECAL, Danger, Blades
0020	1755715YP	1	DECAL, Mower Width
0030	1721107SM	1	DECAL, Danger, Discharge
0040	48X511MA	1	DECAL, Drawbar
0050	1755843YP	1	BADGE, Steering
0060	1722806SM	1	DECAL, Ignition
0080	1755900YP	1	BADGE, LH
0090	1750191YP	1	DECAL, Tunnel
0100	7101935YP	1	DECAL, Roll Release
0120	1759026YP	1	DECAL, Regent, RD
0140	1755901YP	1	BADGE, RH
0220	1755798YP	1	BADGE, Simplicity
0230	1755716YP	1	DECAL, Mower Width
0370	1759906YP	1	DECAL, SRD200
0380	1759905YP	1	DECAL, SRD100
0390	1759907YP	1	DECAL, SRD300

Not For
Reproduction

Electrical Group

Note: Unless noted otherwise, use the standard torque specifications

Mfg. No: 2691297-01

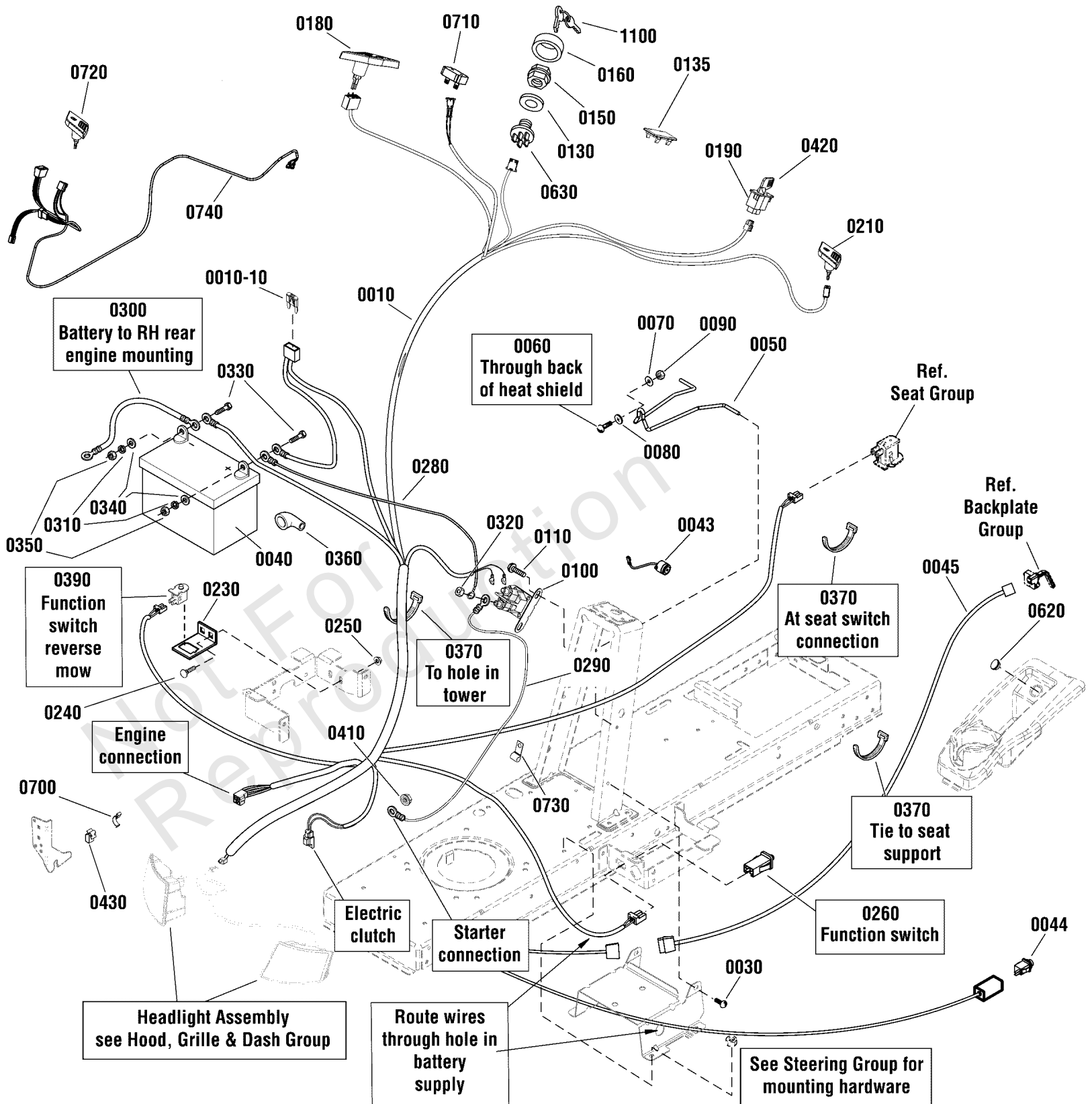

Electrical Group

REF NO	PART NO	QTY	DESCRIPTION
0010	1758955YP	1	WIRING HARNESS
0010-10	-----	1	* FUSE, 20 Amp
0030	703949	2	SCREW, Washer Head, 5/16-18 X 5/8
0040	-----	1	BATTERY, 7U1L
0043	1758779YP	1	BUZZER, Bag Full
0044	1001845MA	1	SWITCH, Bagger
0045	885692YP	1	HARNESS, Bag Full
0050	1730007SM	1	HOLD DOWN, Battery, 1/4 Dia.
0060	1931318SM	1	BOLT, Carriage, Short Neck, 1/4-20 x 7/8 G5
0070	703229	1	WASHER, 1/4 x 27/32
0080	703826	1	NUT, Nylock, 5/16-18
0090	703232	1	NUT, Hex Lock, 1/4-20, ESNA
0100	1755381YP	1	SOLENOID
0110	704130	2	SCREW, Hex Head, 1/4-20 X 1/2
0130	2101025SM	1	WASHER, 5/8
0135	1722611SM	1	PLUG, Hole, .85 X 1.73
0150	1717549SM	1	NUT, Hex Flange, 5/8-32 IGN SW DIE CAST
0160	1717550SM	1	COVER, Ignition Switch
0180	1738982YP	1	SWITCH, PTO
0190	1726556SM	1	SWITCH, Reverse Mow Module
0210	1738983YP	1	SWITCH, Light
0230	1728026BMYP	1	SUPPORT, RMO Switch
0240	703185	2	BOLT, Carriage, 5/16-18 X 3/4
0250	703409	2	NUT, Serrated Lock Flange, 5/16-18
0260	7022886YP	1	SWITCH, DP, NO/NC, Snap-In
0280	1752685YP	1	CABLE, Two Ring, #6 x 10
0290	1751450YP	1	CABLE, #6 x 25
0300	1752686YP	1	CABLE, # 6 x 26
0310	704133	2	WASHER
0320	2860750SM	2	NUT, Hex Lock, KEPS, 5/16-24
0330	703925	2	CAPSCREW, Hex Head, 1/4-20 x 5/8, GR5
0340	703332	2	WASHER, Flat, 1/4
0350	703127	2	NUT, Hex, 1/4-20
0360	1677296SM	1	BOOT, Insulator, Battery Terminal PVC Red
0370	703586	8	TIE, Cable
0390	1732004SM	1	SWITCH, Push Button, NO, Black
0410	703233	1	NUT, Serrated, Flange, 1/4-20, GR5
0420	1726557SM	2	KEY, No Mow Module (Yellow)
0430	2172434SM	2	CLIP, Wire, .390 Dia.
0620	1732007SM	1	PLUG, Hole, 7/8 Dia.
0630	1737853YP	1	SWITCH ASSEMBLY, Ignition Indak No Keys/Hdwr
0700	703176	1	CLIP, Wire
0710	1731185SM	1	HOUR METER, Digital, No Alarms -(Use on 2691263-00)
0710	1758654YP	1	DISPLAY, Mini Meter -(Use where applicable)
0720	1758683YP	1	GAUGE, Fuel -(Use where applicable)
0730	7012652YP	1	CLIP, Wire, 7/16

Footnotes:

Note* See your local hardware store for replacement fuses.

Electrical Group

Note: Unless noted otherwise, use the standard torque specifications

Mfg. No: 2691297-01

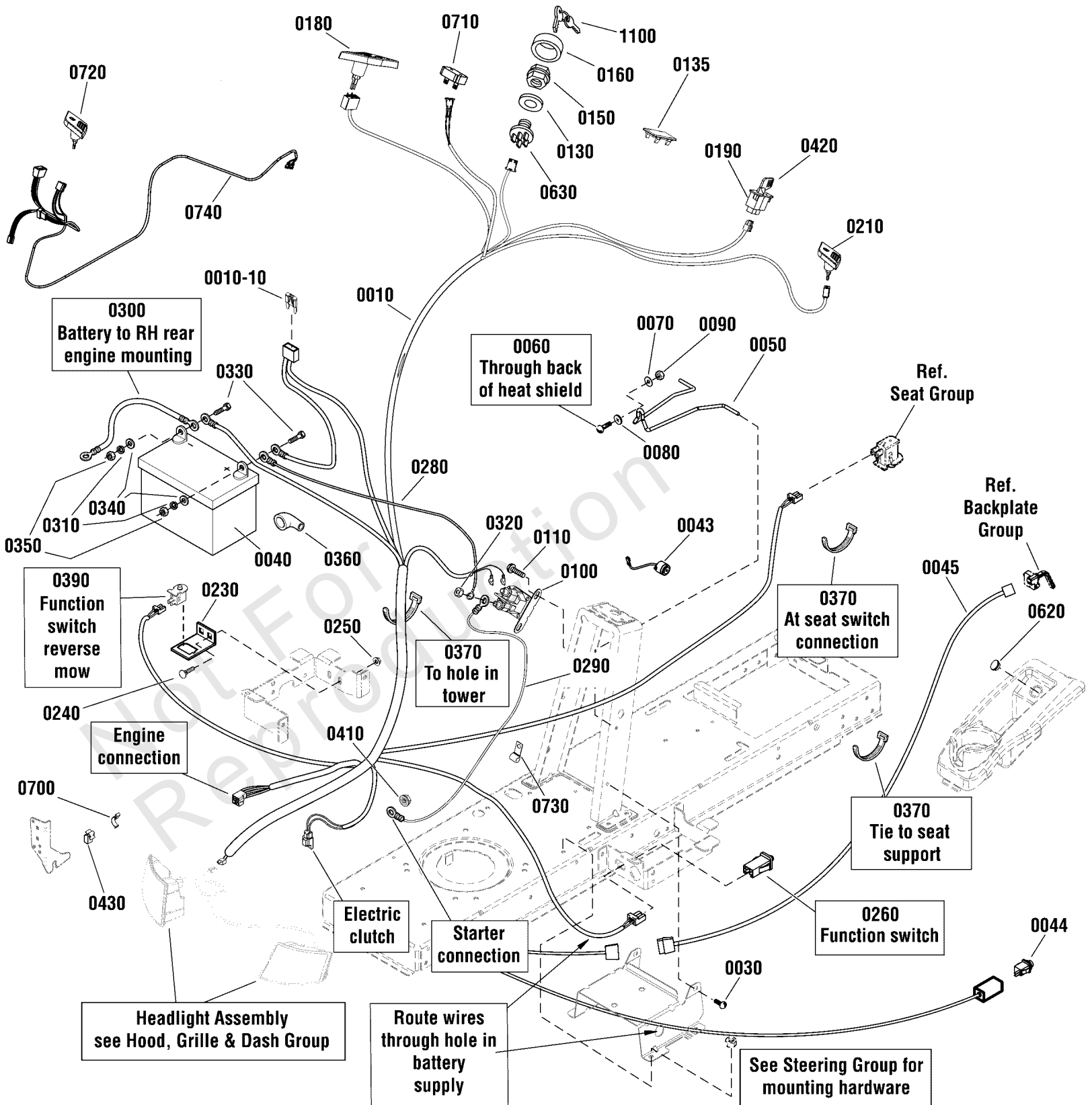

Electrical Group

REF NO	PART NO	QTY	DESCRIPTION
0740	1758739YP	1	HARNESS, Jumper
1100	1737837YP	1	KEYS, Ignition

Not For
Reproduction

Footnotes:

Note* See your local hardware store for replacement fuses.

Engine Group

Note: Unless noted otherwise, use the standard torque specifications

Mfg. No: 2691297-01

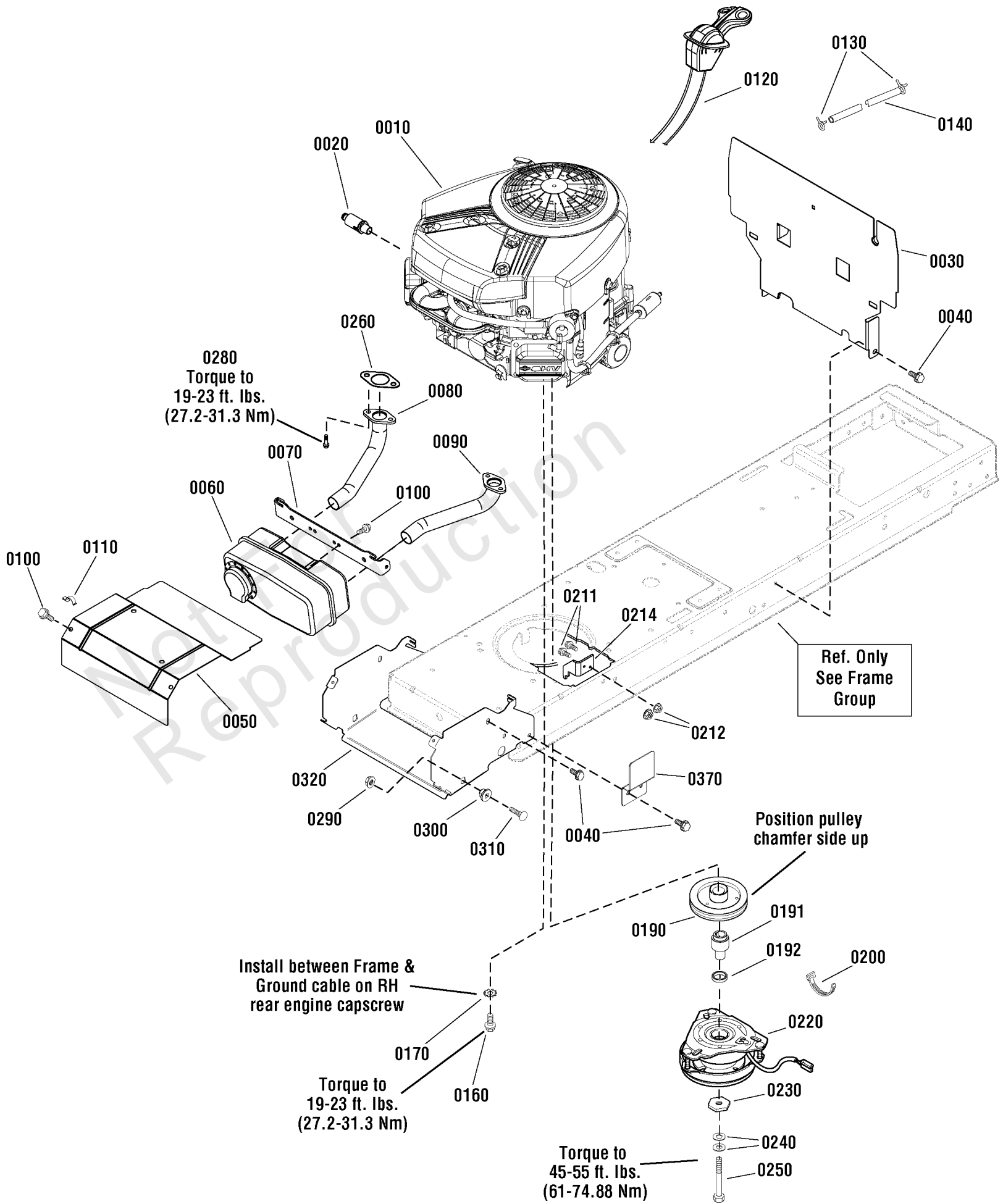

Engine Group

REF NO	PART NO	QTY	DESCRIPTION
0010	40R877-0025-B1	1	* ENGINE, Briggs & Stratton 7220 Intek, Twin Series -(Engine Model: 40R877-0025-B1)
0010	44S877-0039-B1	1	* ENGINE, Briggs & Stratton 8270 Twin Series -(Engine Model: 44S877-0039-B1)
0010	44U877-0004-B1	1	* ENGINE, Briggs & Stratton 8270 Twin Series -(Engine Model: 44U877-0004-B1)
0020	1750159YP	1	VALVE, Drain
0030	1728058BMYP	1	HEAT SHIELD, Engine
0040	703949	8	SCREW, Washer Head, 5/16-18 X 5/8
0050	1727997ASM	1	HEAT SHIELD, Engine, Twin
0060	885954YP	1	MUFFLER, Twin
0070	1727976BMYP	1	SUPPORT, Muffler
0080	1727979SM	1	PIPE, Exhaust, Flanged, R.H, 1 1/8 OD
0090	1727980SM	1	PIPE, Exhaust, Flanged, L.H, 1 1/8 OD
0100	704130	4	SCREW, Hex Head, 1/4-20 X 1/2
0110	2172434SM	1	CLIP, Wire, .390 Dia.
0120	1736868YP	1	CONTROL, Throttle, Choke-A-Matic
0130	791850	2	CLAMP, Hose
0140	845503	1	LINE, Fuel
0160	704000	4	SCREW, Hex Washer Head, Taptite, 3/8-16 x 1
0170	703864	1	WASHER, External, 3/8
0190	1732576SM	1	PULLEY & HUB ASSEMBLY, Engine
0191	885679YP	1	SPACER, Electric Clutch
0192	885810YP	1	SPACER, Electric Clutch, Lower
0200	1701011SM	3	TIE, Self Locking, 15" Long
0211	704287	2	CAPSCREW, Hex Head, 5/16-18 x 3/4, GR5
0212	703409	2	NUT, Serrated Lock Flange, 5/16-18
0214	885535AYP	1	BRACKET, Electric Clutch Torque
0220	885680YP	1	CLUTCH, Electric, GT1A-EH07
0230	1708264SM	1	WASHER, Hex
0240	1960769YP	2	WASHER, Belleville
0250	7102075YP	1	CAPSCREW, Hex Head, 7/16-20 x 5, G5
0260	690970	2	GASKET, Exhaust
0280	690341	4	SCREW
0290	703409	2	NUT, Serrated Lock Flange, 5/16-18
0300	1728086SM	2	PIVOT, Hood, Powdered Metal
0310	703800	2	BOLT, Carriage, 5/16-18 X 1
0320	1727982BMYP	1	SUPPORT, Muffler
0370	1738798BMYP	2	GUARD, Front

Footnotes:

Note* To verify your specific engine model, please reference the ID Tag located on your engine. See your local Briggs & Stratton distributor for parts and service.

Frame Group

Note: Unless noted otherwise, use the standard torque specifications

Mfg. No: 2691297-01

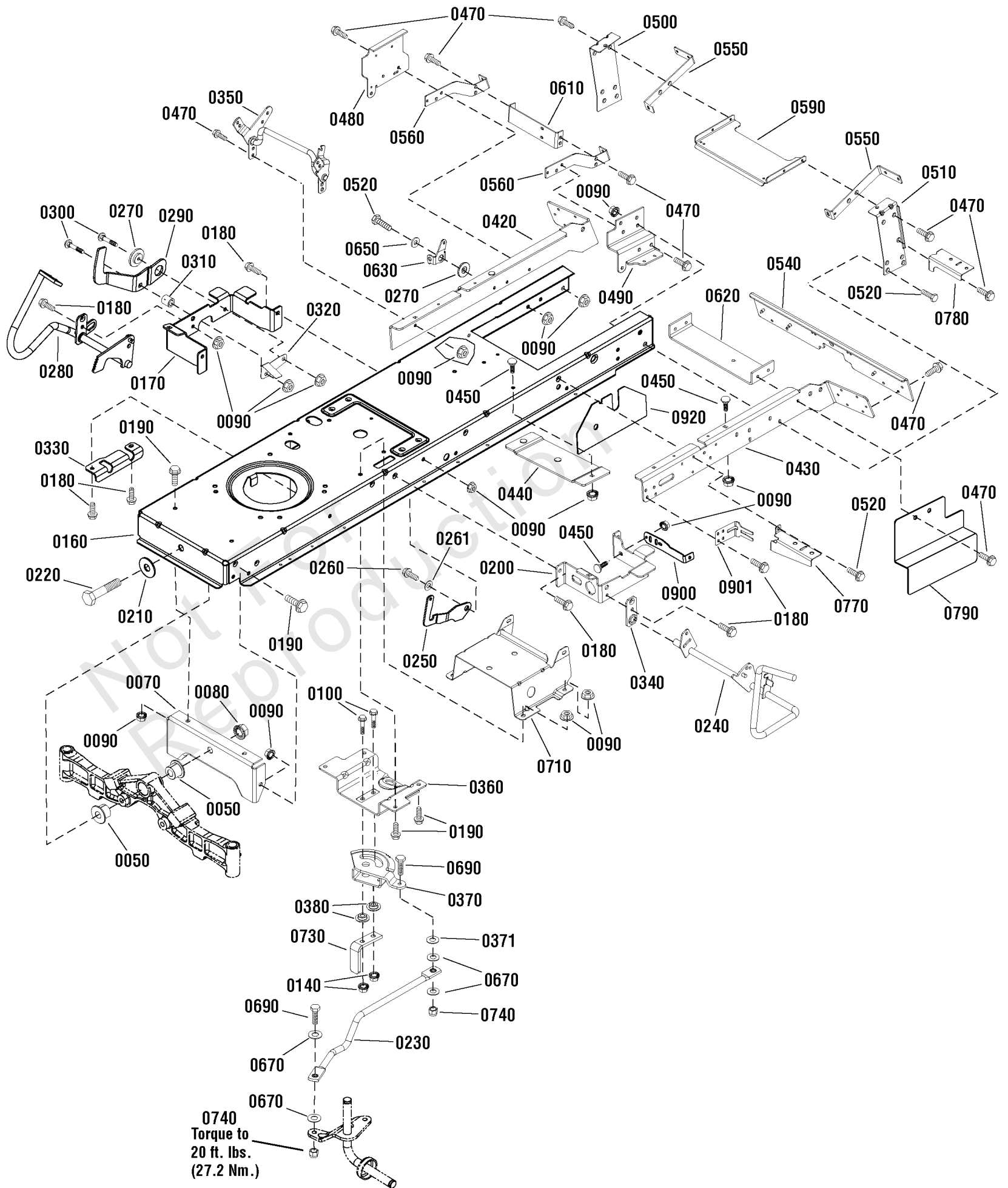

Frame Group

REF NO	PART NO	QTY	DESCRIPTION
0050	1730186SM	2	BUSHING, Axle Pivot
0070	1727902SM	1	PLATE, Axle Support
0080	2860646SM	1	NUT, Hex Flange, 5/8-11
0090	703409	36	NUT, Serrated Lock Flange, 5/16-18
0100	1960032SM	2	SCREW, Hex Head, 3/8-16 x 1 1/4
0140	703893	2	NUT, Hex, Flange, Two Way Lock, 3/8-16
0160	1758743	1	FRAME -(Not a serviceable part)
0170	1727904SM	1	SUPPORT, Front Footrest, RH
0180	703949	12	SCREW, Washer Head, 5/16-18 X 5/8
0190	703354	10	SCREW, Flange, Whiz-Lock, 5/16-18 X 3/4
0200	885536AYP	1	SUPPORT, Front Footrest L.H.
0210	1960035SM	1	WASHER, 5/8
0220	2860744SM	1	CAPSCREW, Hex Head, 5/8-11 x 3 1/4
0230	1738051YP	1	LINK, Drag (with Bearing), 5/16
0240	1755925YP	1	PEDAL ASSEMBLY, Brake
0250	1735595YP	1	LATCH, Brake Lock
0260	703851	1	BOLT, Shoulder, 5/16-18 x 1 1/8
0261	7014296YP	1	WASHER, Shim
0270	1727935SM	2	SPACER, Pivot
0280	1736714AYP	1	FORWARD PEDAL ASSEMBLY
0290	1727246SM	1	PEDAL, Reverse
0300	703446	2	BOLT, Carriage, 5/16-18 X 1 1/4, GR5
0310	1728024SM	1	SPACER, Foot Pedal
0320	1728025BMYP	1	ACTUATOR, RMO Switch
0330	885591AYP	1	BRACKET, Pedal Pivot
0340	1727911ASM	1	PLATE, Bearing
0350	1758772YP	1	LIFT SHAFT ASSEMBLY
0360	1727940SM	1	BRACKET, Sector Support
0370	1751110YP	1	GEAR, Steering
0371	703298	1	WASHER, 5/16
0380	1728122SM	2	SPACER, Sector Gear
0420	1758741YP	1	BRACKET, Rear Frame, RH
0430	1758740YP	1	BRACKET, Rear Frame, LH
0440	885532AYP	1	BRACE, Middle Cross
0450	703185	9	BOLT, Carriage, 5/16-18 X 3/4
0470	703228	26	SCREW, Washer Head Taptite, 5/16-18 X 3/4
0480	885474AYP	1	BRACKET, Transaxle, RH
0490	885475AYP	1	BRACKET, Transaxle, LH
0500	885411AYP	1	SUPPORT, Deck, R.H.
0510	885412AYP	1	SUPPORT, Deck, L.H.
0520	703585	13	CAPSCREW, Hex Head, 5/16-18 x 1
0540	885469AYP	1	BRACKET, Middle Back Plate
0550	1758921YP	2	SUPPORT, Upper, Back Plate
0560	885467AYP	2	SUPPORT, Lower, Back Plate
0590	885503AYP	1	BRACE, Cross Deck Support
0610	885890YP	1	BRACKET, Torque
0620	885486AYP	1	BRACKET, Idler Mount
0630	1728990ASM	1	CLEVIS, Lift
0650	1960044SM	1	WASHER, Flat, 5/16
0670	1919326SM	4	WASHER, 5/16

Frame Group

Note: Unless noted otherwise, use the standard torque specifications

Mfg. No: 2691297-01

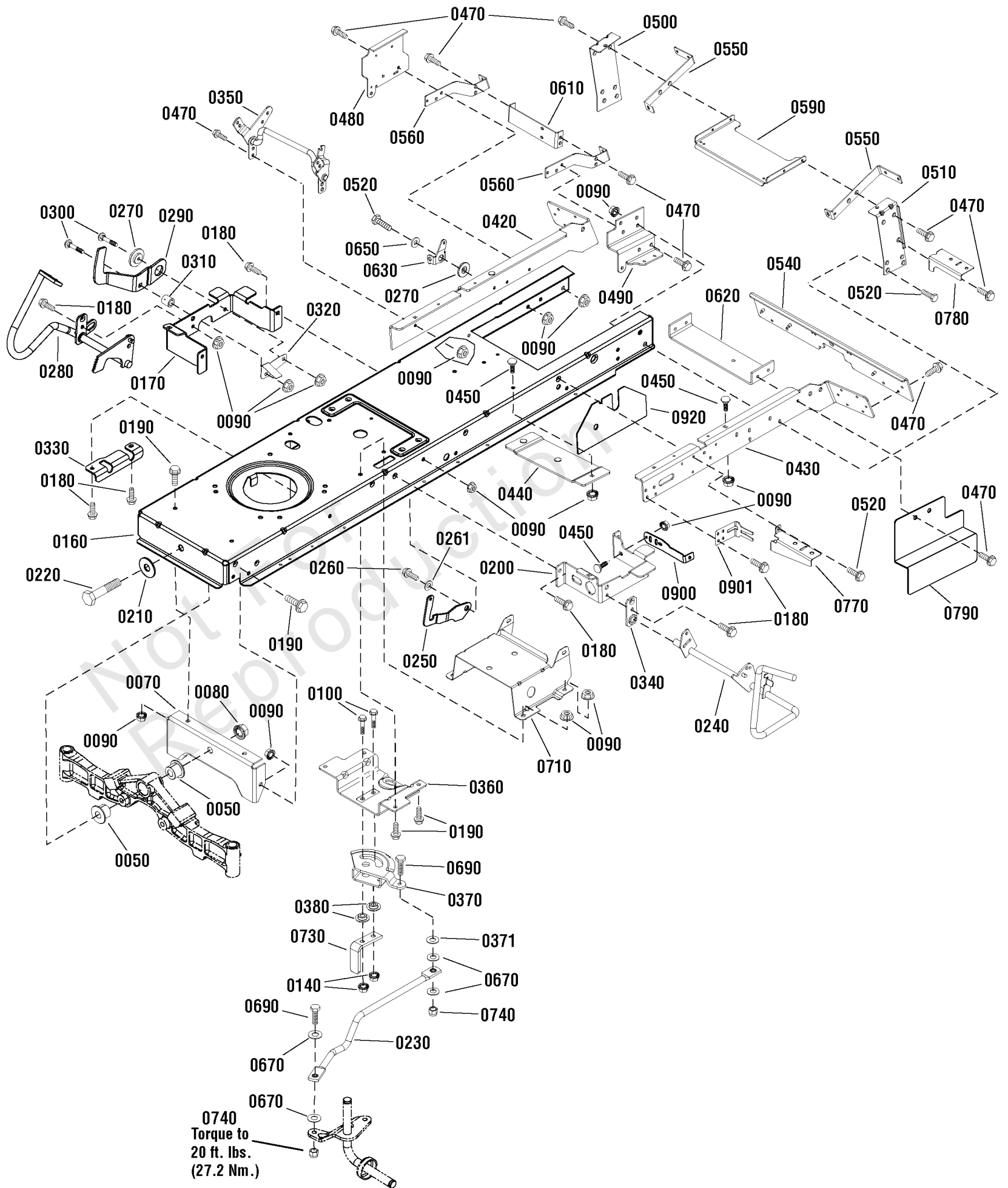

Frame Group

REF NO	PART NO	QTY	DESCRIPTION
0690	703570	2	CAPSCREW, Hex Head, 5/16-18 x 1 1/4
0710	1727282ASM	1	SUPPORT, Battery 12 GA
0730	885791YP	1	UPSTOP
0740	704067	2	NUT, Hex Flange, 5/16-18
0770	1758692YP	1	BRACKET, Fuel Tank, Front
0780	1758691YP	1	BRACKET, Fuel Tank, Rear
0790	885892YP	2	GUARD, Rear
0900	1759729CJYP	2	SUPPORT
0901	1759730CJYP	2	SUPPORT, Frame
0920	1760020BMYP	2	GUARD, Midframe

Not For
Reproduction

Front Axle Group

Note: Unless noted otherwise, use the standard torque specifications

Mfg. No: 2691297-01

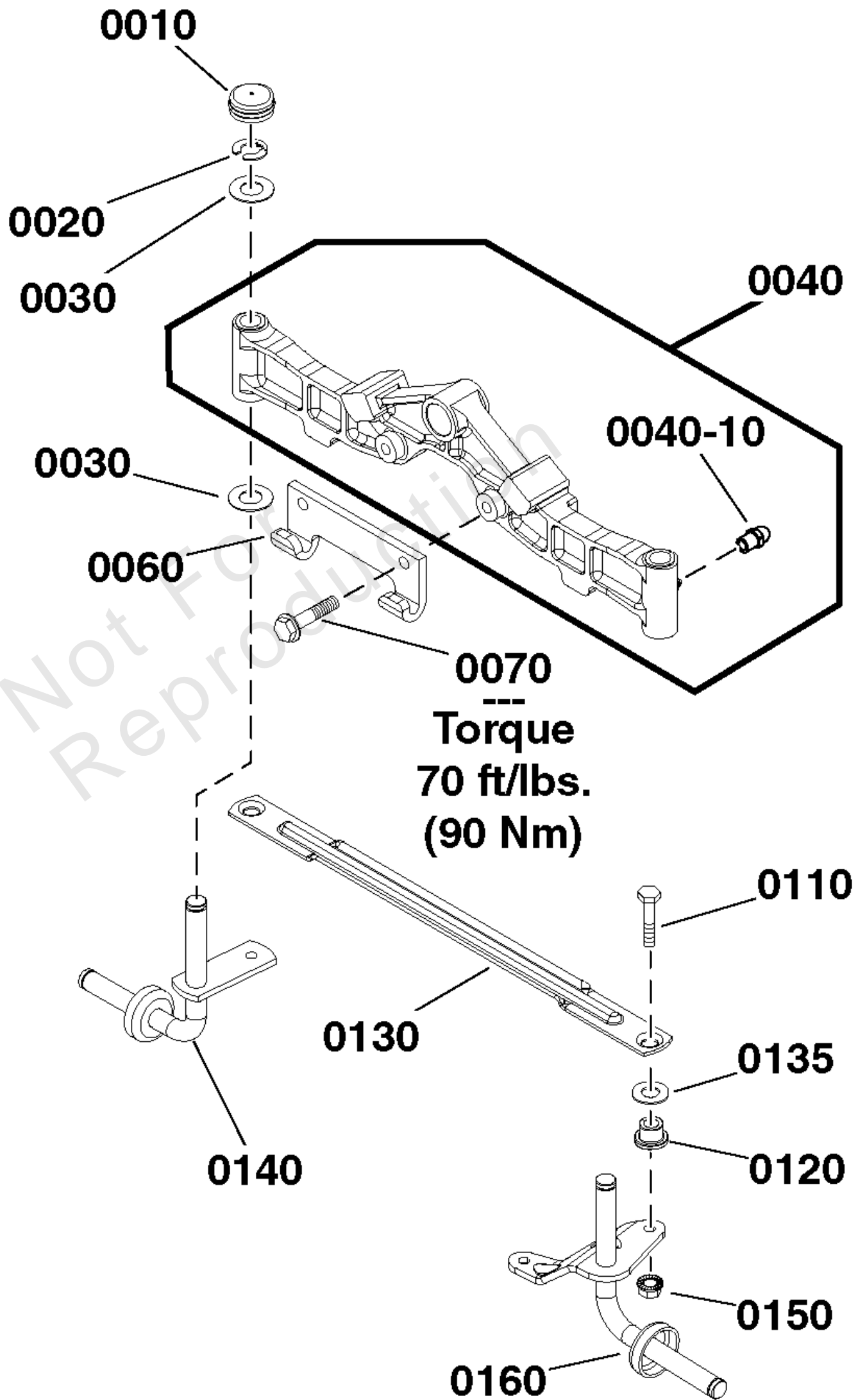

Front Axle Group

REF NO	PART NO	QTY	DESCRIPTION
0010	1734135SM	2	CAP, Hub
0020	1611710SM	2	E-RING, 3/4
0030	2860183SM	4	WASHER, Flat, 3/4
0040	1756386YP	1	AXLE, Front
0040-10	1704314SM	2	FITTING, Zerk -(Included with Ref. No. 0040)
0060	1721918ASM	1	HOOK, Mower, Hitch
0070	1960652SM	2	SCREW, Hex Flange, Whiz Lock, 7/16-14 x 1-1/2
0110	1960032SM	2	SCREW, Hex Head, 3/8-16 x 1 1/4
0120	1731912SM	2	BUSHING, 3/8 ID x 5/8 OD x 1/2
0130	1751964YP	1	TIE ROD
0135	1960703SM	2	WASHER, 5/8
0140	1727872ASM	1	SPINDLE ASSEMBLY, R.H.
0150	703893	2	NUT, Hex, Flange, Two Way Lock, 3/8-16
0160	1751922YP	1	SPINDLE ASSEMBLY, L.H.

Not For
Reproduction

Hood, Grille & Dash Group

Note: Unless noted otherwise, use the standard torque specifications

Mfg. No: 2691297-01

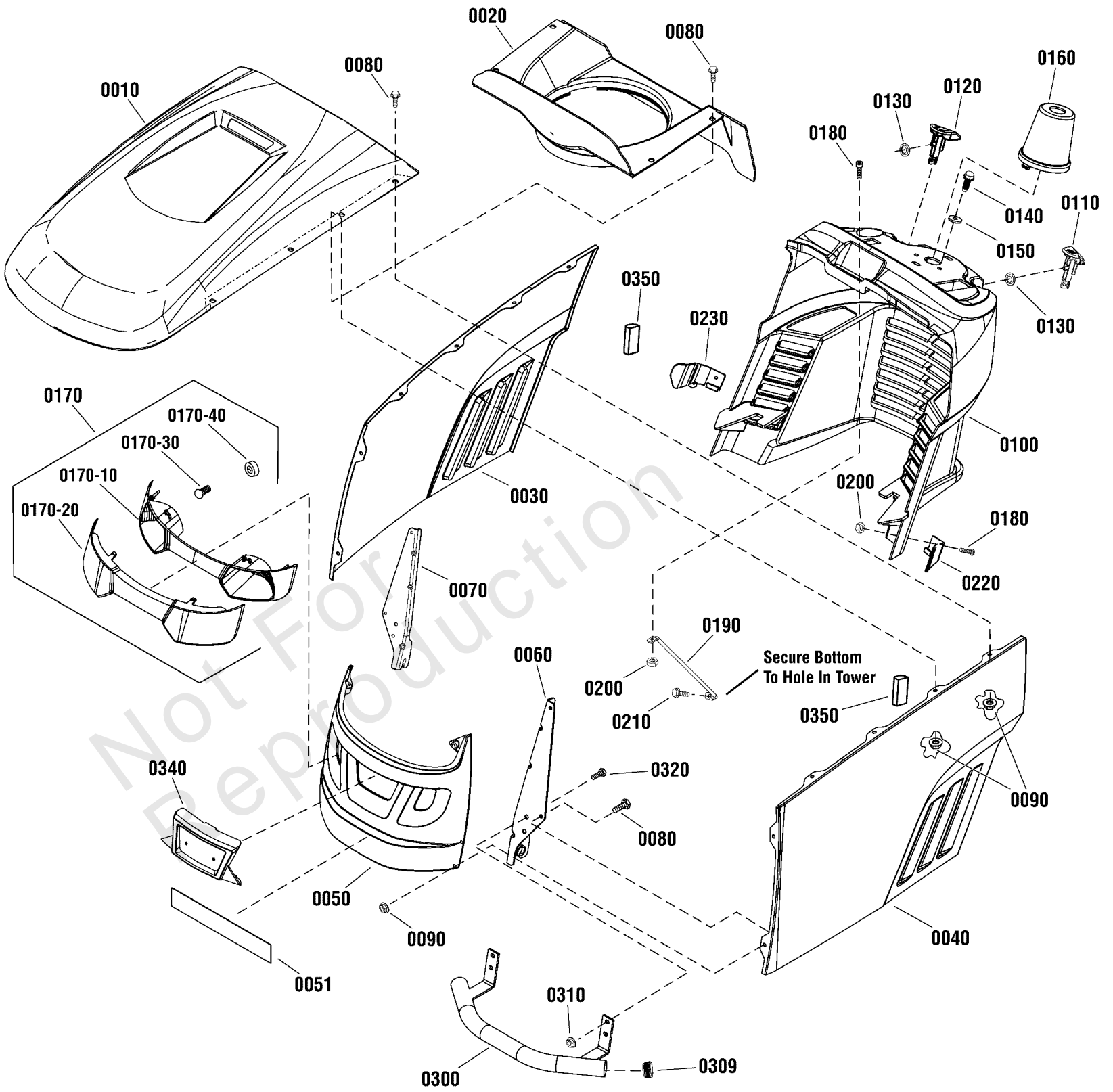

Hood, Grille & Dash Group

REF NO	PART NO	QTY	DESCRIPTION
0010	1754921CYP	1	HOOD, Top
0020	7102326YP	1	DUCT, Air Inlet Plastic
0030	1755497CYP	1	PANEL, Hood R.H.
0040	1755498CYP	1	PANEL, Hood, L.H.
0050	1727297CSM	1	GRILLE
0051	1758731YP	1	INSULATION
0060	1727279BMYP	1	HINGE, Hood L.H.
0070	1727280ASM	1	HINGE, Hood R.H.
0080	1960295SM	12	CAPSCREW, Whizlock, 1/4-20 x 5/8
0090	703161	12	NUT, 1/4-20, Hex Flange Whiz Lock
0100	1758660YP	1	DASHBOARD
0110	1728089SM	1	KNOB, Brake Lock Plastic
0120	1728090SM	1	KNOB, Cruise Lock Green Plastic
0130	1960518SM	2	NUT, Push Pal
0140	703228	2	SCREW, Washer Head Taptite, 5/16-18 X 3/4
0150	703298	2	WASHER, 5/16
0160	1727999SM	1	COVER, Steering Shaft Plastic
0170	1727296SM	1	HEADLIGHT ASSEMBLY (Includes Ref. Nos. 0170-10, 0170-20, 0170-30 &
0170-10	1728973SM	1	REFLECTOR, Headlight
0170-20	1728974SM	1	LENS, Headlight
0170-30	1755317YP	2	BULB, LED (1156) -(Use Before Serial Number 2017697319)
0170-30	1760239YP	2	LED HEADLIGHT AND SOCKET ASSEMBLY -(Use After Serial Number 2017697318)
0170-40	1723451SM	2	SOCKET ASSEMBLY
0180	1960392SM	3	SCREW, Pan Head Phillips, #10-24 x 1
0190	1723123SM	1	ROD, Dash Support
0200	703412	3	NUT, Nylock, #10-24
0210	1925003SM	1	SCREW, Self-Tap
0220	1732030SM	1	GUIDE, Hood L.H.
0230	1732031SM	1	GUIDE, Hood R.H.
0300	1731270BMYP	1	BUMPER
0309	7102347YP	1	PLUG
0310	703409	4	NUT, Serrated Lock Flange, 5/16-18
0320	703354	4	SCREW, Flange, Whiz-Lock, 5/16-18 X 3/4
0340	1755583YP	1	INSERT, Headlight
0350	1754094YP	2	POSITIONER, Hood

Lift Group (885450)

Note: Unless noted otherwise, use the standard torque specifications

Mfg. No: 2691297-01

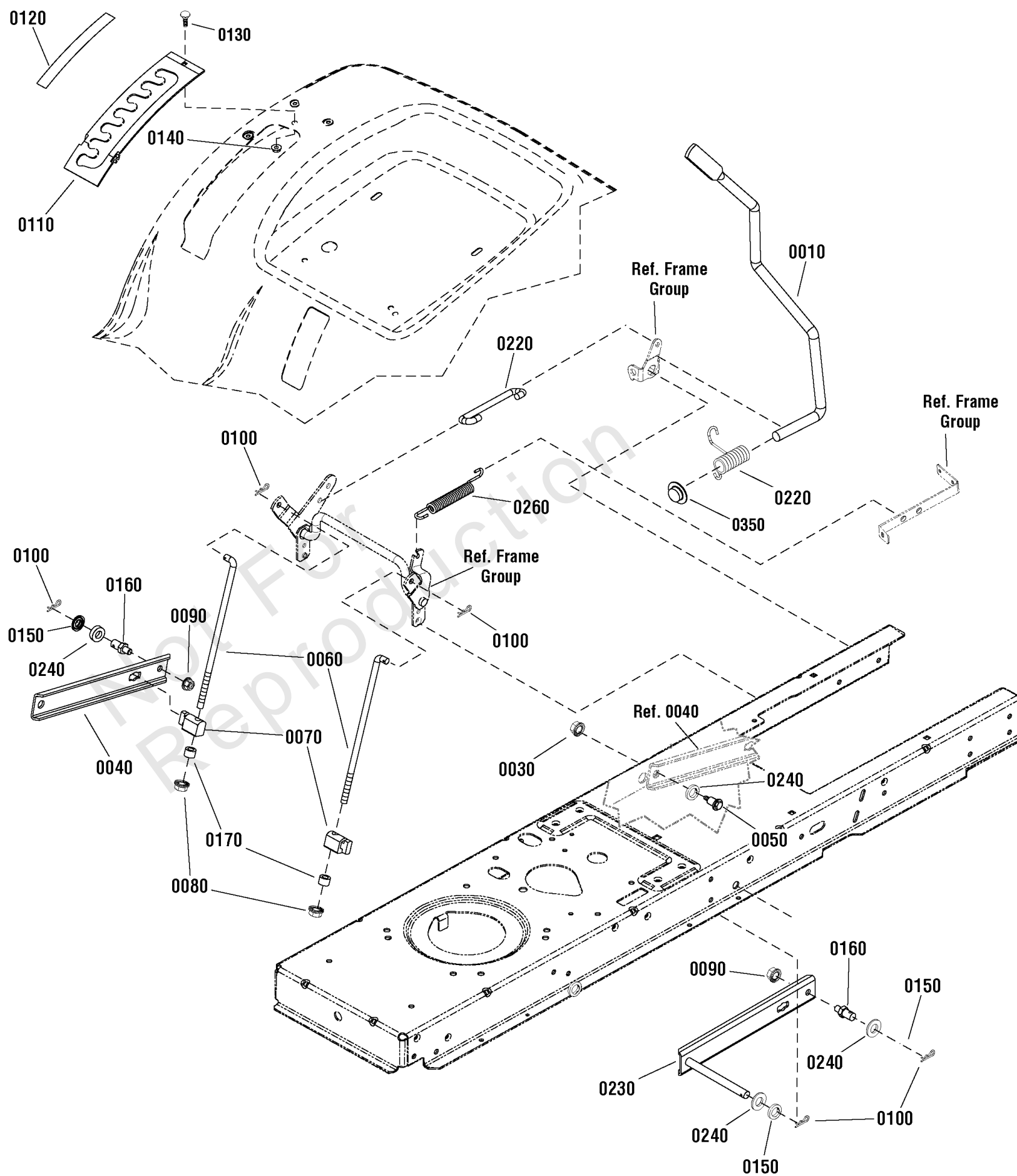

Lift Group (885450)

REF NO	PART NO	QTY	DESCRIPTION
0010	1728070SM	1	ROD, Lift Handle, 18-7/8"
0020	1729652SM	1	SPRING, Torsion
0030	1931277SM	1	NUT, Hex Flange Whiz Lock Small, 5/16-18
0040	1731417BMYP	1	ARM, Rear Lift
0050	1732426SM	1	BOLT, Shoulder, 5/16-18
0060	1727955SM	2	ROD, Lift, Lower, 3/8 x 10 Long
0070	1731894SM	2	TRUNNION
0080	1960687SM	2	NUT, Hex Flange Nylock, ESNA, 3/8-16
0090	1931211SM	2	NUT, Hex Flange Whiz Lock Small, 3/8-16
0100	1960074SM	5	CLIP, Hair Pin, 1-5/8
0110	1727985ASM	1	QUADRANT, Lift Height
0120	1730264SM	1	DECAL, Height Of Cut
0130	1960252SM	1	BOLT, Carriage, 1/4-20 x 5/8
0140	1930641SM	1	NUT, Hex Flange Whiz Lock, 1/4 - 20
0150	1960170SM	2	WASHER, 1/2 x 1 OD
0160	721221	2	PIN, Threaded, Shoulder, 3/8-16x1-7/16 Long
0170	1666294SM	2	SPACER, .385 ID x .6697 OD x .455 Long
0220	1727954SM	1	ROD, Lift .375 dia
0230	885523AYP	1	ARM, Rear Lift, LH
0240	885382YP	4	WASHER, Rubber
0250	720173	1	WASHER, Flat, 13/16
0260	722453	1	SPRING, Extension
0350	771009	1	PUSHNUT

Mulch Plug Group

Note: Unless noted otherwise, use the standard torque specifications

Mfg. No: 2691297-01

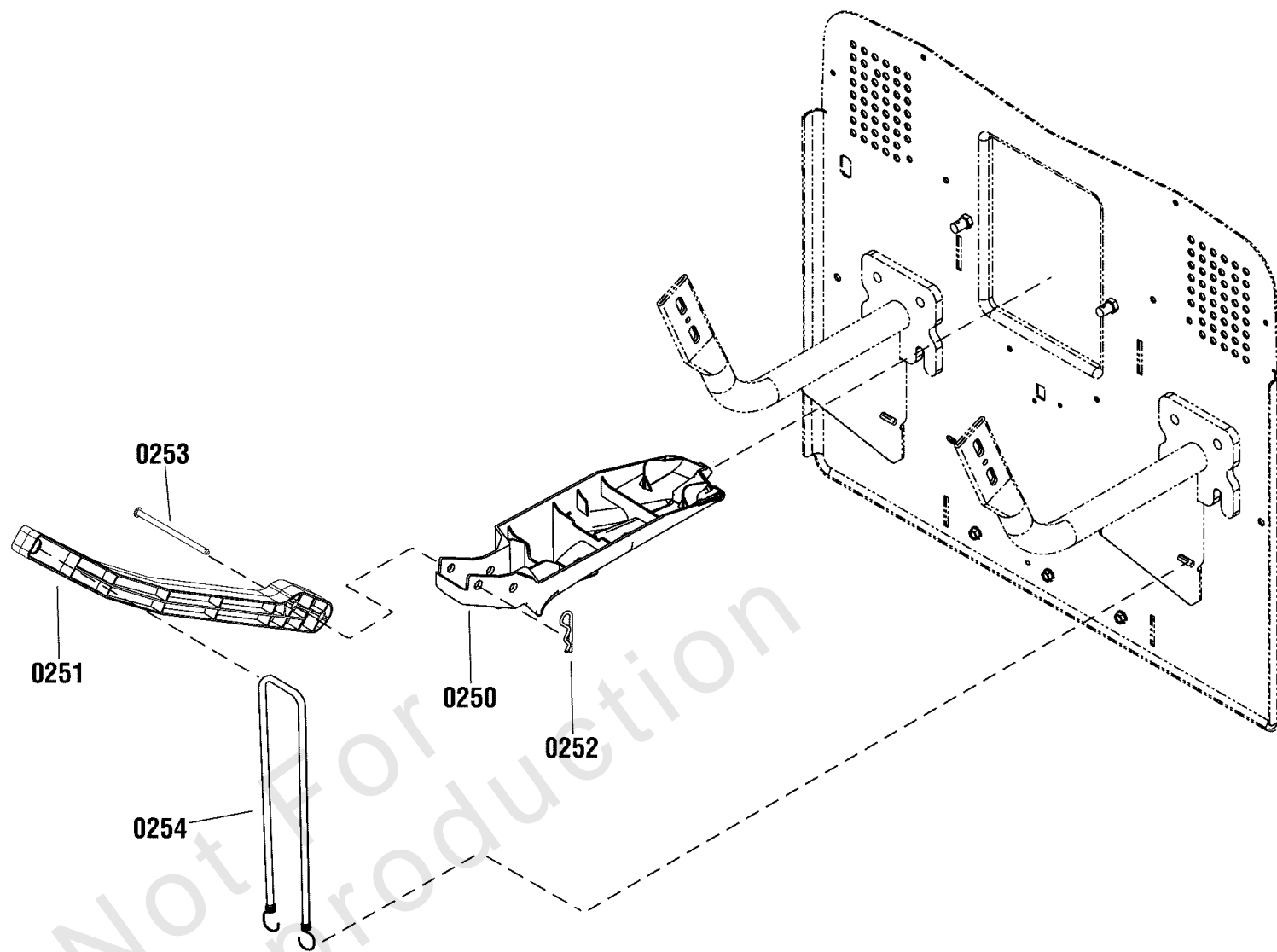

Mulch Plug Group

REF NO	PART NO	QTY	DESCRIPTION
0250	885642	1	Plug, Mulch, 96cm (38")
0250	885960	1	Plug, Mulch, 107cm (42")
0251	885643	1	HANDLE, Mulch Plug
0252	885647	2	PIN, Clevis, 3/8
0253	1960074	2	PIN, Hair Pin
0254	885648	1	CORD, Retainer

Not For
Reproduction

Seat Deck & Fuel Tank Group

REF NO	PART NO	QTY	DESCRIPTION
0010	1758849CYP	1	SEAT DECK, Orange
0020	703185	4	BOLT, Carriage, 5/16-18 X 3/4
0030	703409	6	NUT, Serrated Lock Flange, 5/16-18
0031	1709256SM	4	WASHER, Spring, 5/16 x 1 1/4
0040	1728007SM	1	PAD, Footrest, RH
0050	1728006SM	1	PAD, Footrest, LH
0060	1758414YP	1	FUEL TANK ASSEMBLY
0060-10	1654930SM	1	BUSHING, Fuel Tank
0060-20	-----	1	FUEL TANK
0060-30	1758506YP	1	TUBE, Fuel Pickup
0060-40	1758611YP	1	SENDER, Fuel
0060-50	1758898YP	1	PLATE, Mounting, Fuel Sender
0060-60	2860665SM	5	SCREW, Pan Head Torx, #10-32 x 1/2
0060-70	5101651SM	1	CAP, Fuel
0063	197546GS	5	MOUNT, Vibration
0070	1758774YP	1	POD, LH
0081	1738013YP	1	SEAT, Bottom
0082	1738014YP	1	SEAT, Top
0083	1737848BMYP	2	Support, Seat
0084	703354	8	SCREW, Flange, Whiz-Lock, 5/16-18 X 3/4
0085	1738015YP	1	SWITCH, Seat
0090	1731300SM	4	SPACER, 5/16 ID x 1-1/4 OD x 5/16"
0100	1755767BMYP	1	SUPPORT, Seat
0110	1727268BMYP	1	LATCH, Seat
0120	1930595SM	4	Screw, Whiz Lock, 5/16 x 1 1/4
0130	703298	4	WASHER, 5/16
0180	1739934YP	2	BUMPER
0190	885538AYP	1	PIVOT, Seat
0200	703949	2	SCREW, Hex Washer Head, Taptite, 5/16-18 x 5/8
0210	1739537YP	1	POD, RH
0220	1960536SM	6	SCREW, Hex Washer Head, Plastite, 1/4 x 1/2
0230	1722302SM	1	GRIP
0250	703851	2	BOLT, Shoulder, 5/16-18 x 1 1/8
0260	703115	4	NUT, Flange Nylock, 5/16-18
0300	885382YP	2	WASHER, Rubber
0390	1923114SM	1	CAPSCREW, Hex Head, 1/2-13 x 1, GR 5
0400	703853	1	WASHER, 1/2
0410	5025038SM	1	NUT, Hex, 1/2-13
0430	5022673SM	1	FOAM
0450	5022673SM	1	BUMPER
0460	703233	1	NUT, 1/4-20

Transmission Group - Hydro Gear

Note: Unless noted otherwise, use the standard torque specifications

Mfg. No: 2691297-01

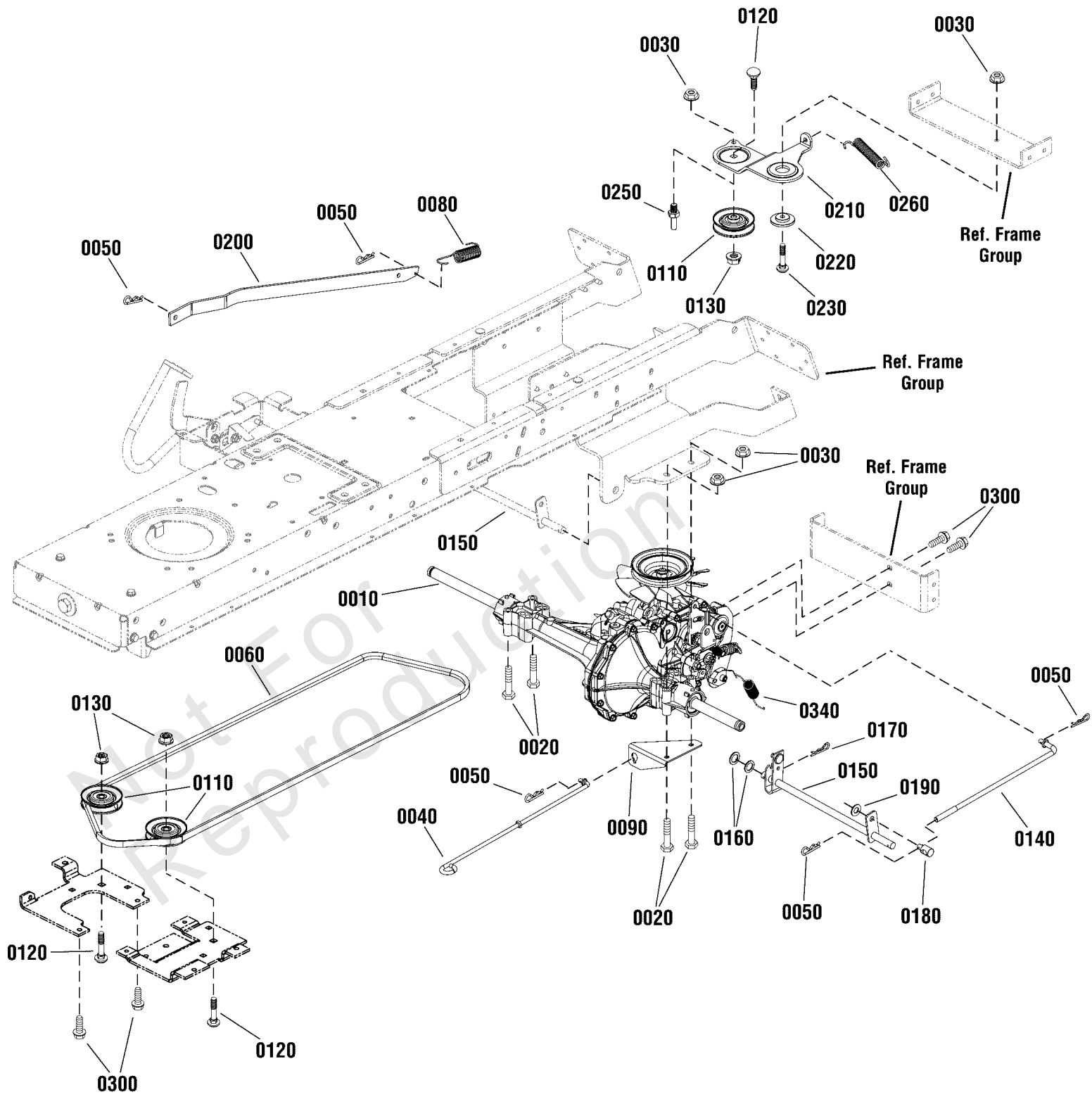

Transmission Group - Hydro Gear

REF NO	PART NO	QTY	DESCRIPTION
0010	885528YP	1	* TRANSMISSION, Hydro Gear, 610
0020	1923141SM	4	SCREW, Hex Head Flange Lock, 5/16-18 x 2-3/4, G5
0030	1931277SM	4	NUT, Hex Flange, Whiz Lock, 5/16-18
0040	885436YP	1	LEVER, Roll Release
0050	1722460SM	5	PIN, Quick
0060	885495YP	1	BELT, Secondary
0080	165X75MA	1	SPRING, Extension
0090	885868BMYP	1	BRACKET, Roll Release
0110	1760012YP	3	PULLEY, Idler
0120	1931352SM	3	BOLT, Carriage, Short Neck, 3/8-16 x 1-1/2
0130	015X84MA	3	NUT, Hex Flange, Centerlock, 3/8-16
0140	885476YP	1	SPEED CONTROL, Short Link
0150	885477AYP	1	SPEED CONTROL ASSEMBLY
0160	017X91MA	2	WASHER, Flat, 13/16
0170	1960074SM	1	PIN, Cotter
0180	021920ZMA	1	NUT, Adjusting
0190	017X53MA	1	WASHER, Flat
0200	885480AYP	1	LINK, Speed Control
0210	885409AYP	1	BRACKET, Idler, Rear
0220	1727935SM	1	SPACER, Pivot
0230	1931335SM	1	BOLT, Carriage, Short Neck, 5/16-18 x 1
0250	885077YP	1	BELT GUIDE
0260	1731939SM	1	SPRING, Extension
0300	703228	4	SCREW, Washer Head Taptite, 5/16-18 X 3/4 -(Only 2 used on Rev - 01)
0340	165X92MA	1	SPRING, Extension

Transmission SERVICE PARTS - Hydro Gear 324-0610 (885528)

Note: Unless noted otherwise, use the standard torque specifications

Mfg. No: 2691297-01

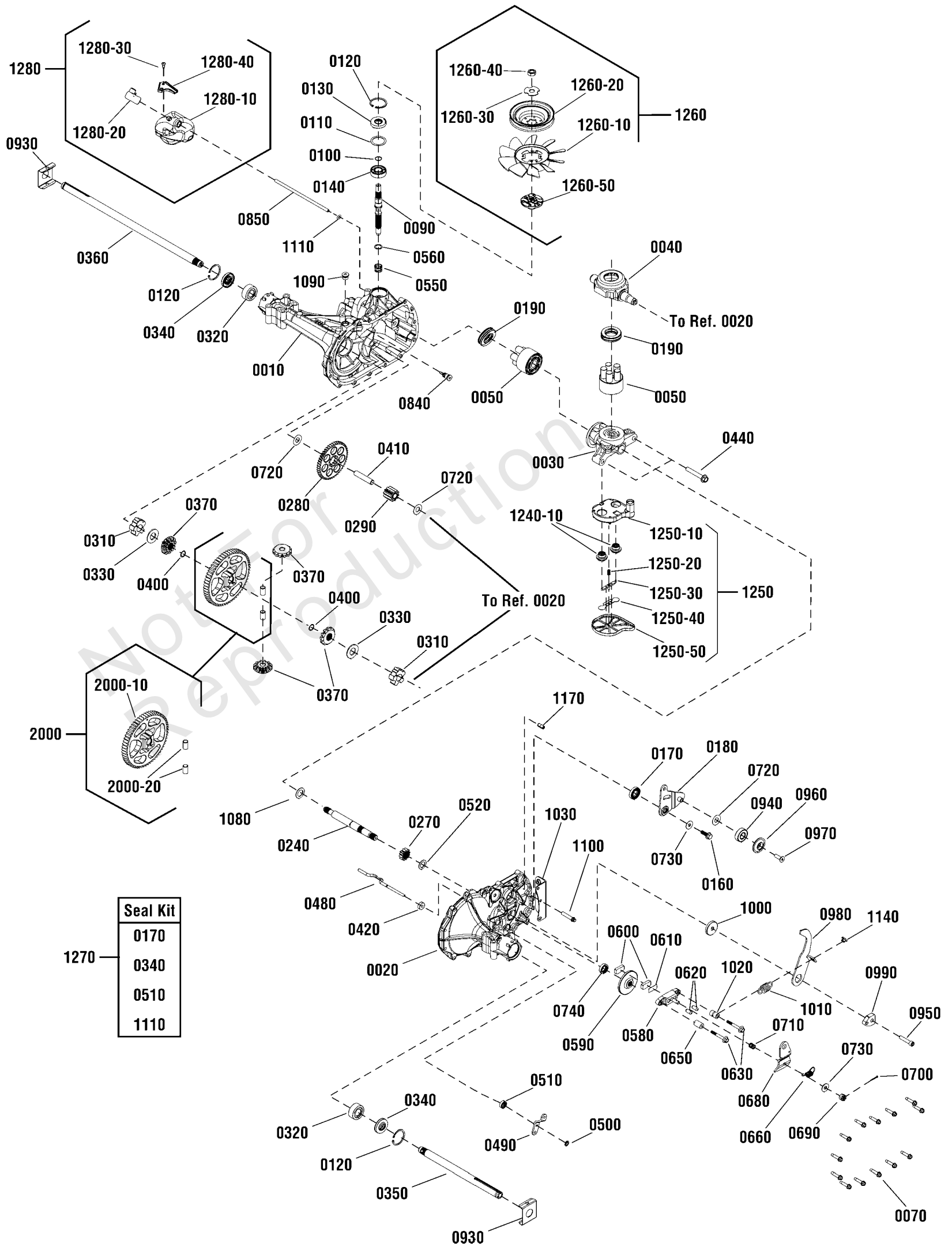

Transmission SERVICE PARTS - Hydro Gear 324-0610 (885528)

REF NO	PART NO	QTY	DESCRIPTION
0010	-----	1	* MAIN HOUSING ASSEMBLY
0020	-----	1	* SIDE HOUSING ASSEMBLY
0030	-----	1	* CENTERSECTION ASSEMBLY
0040	-----	1	* TRUNNION, Swashplate
0050	-----	2	* BLOCK ASSEMBLY
0060	-----	1	* SEALANT, 10.1 oz. -(Not Illustrated)
0070	-----	14	* SCREW, Hex Washer, 1/4-20 x 1-1/8
0090	1752461	1	SHAFT, Input
0100	1715270	1	RING, Retaining
0110	1752462	1	WASHER, Flat, 1.23 x 1.57 x .04
0120	1752463	3	RING, RETAINING
0130	1752464	1	SEAL, LIP 17 x 40 x 12
0140	1752465	1	BEARING, BALL 17 x 40 x 12
0160	-----	1	* SCREW, Hex Flange, With Patch, 5/16-24 x 15/16
0170	-----	1	* SEAL, Lip, 18 x 32 x 7 -(Not a servicable part, order kit # 1270)
0180	-----	1	* ARM, Control
0190	1715144	2	* BEARING, Thrust, 30 x 52 x 13
0240	-----	1	* SHAFT, Motor
0270	-----	1	* GEAR, Pinion, 12T
0280	-----	1	* GEAR, 10T/49T
0290	-----	1	* GEAR, Jackshaft, 10T
0310	-----	2	* BUSHING, Sleeve (Inboard)
0320	-----	2	* BUSHING, Sleeve, 3/4 x 1-1.571 x 5/8
0330	-----	2	* WASHER, Flat, 3/4 x 1-1/2 x 7/64
0340	-----	2	* SEAL, Lip, 3/4 x 1.577 x 1/4 -(Not a servicable part, order kit # 1270)
0350	-----	1	* SHAFT, Axle, 3/4 x 11.39 (Key, RH)
0360	-----	1	* SHAFT, AXLE, 3/4 x 16.99 (Key, LH)
0370	-----	1	* KIT, Miter Gear
0400	-----	2	* RING, Retaining Spiral
0410	-----	1	* PIN, Jackshaft, 1/2 x 2.43
0420	-----	1	* MAGNET, Ring
0440	1717965	2	SCREW, Hex Flange, 3/8-24 x 2-1/2
0480	-----	1	* ROD, Actuator Bypass
0490	-----	1	* ARM, Bypass
0500	-----	1	* RING, Retaining, External, 1/4
0510	-----	1	* SEAL, Lip, 1/4 x 3/4 x 1/4 TC -(Not a servicable part, order kit # 1270)
0520	-----	1	* WASHER, Flat, 5/8 x 1 x 1/2
0530	-----	1	* RING, Retaining
0540	-----	1	* BUSHING, Center Block
0550	-----	1	* SPRING, Block
0560	-----	1	* WASHER, Thrust, .59 x .79 x .04
0580	-----	1	* BRAKE YOKE KIT
0590	-----	1	* DISK, Brake
0600	-----	2	* PUCK, Brake
0610	-----	1	* PLATE, Puck

Footnotes:

Note:* See your local authorized dealership for parts and warranty or contact Hydro Gear at www.hydro-gear.com/Support/NorthAmerica.aspx (U.S. 1-877-728-7410 Int'l 32 (0) 12 670 631)

Transmission SERVICE PARTS - Hydro Gear 324-0610 (885528)

Note: Unless noted otherwise, use the standard torque specifications

Mfg. No: 2691297-01

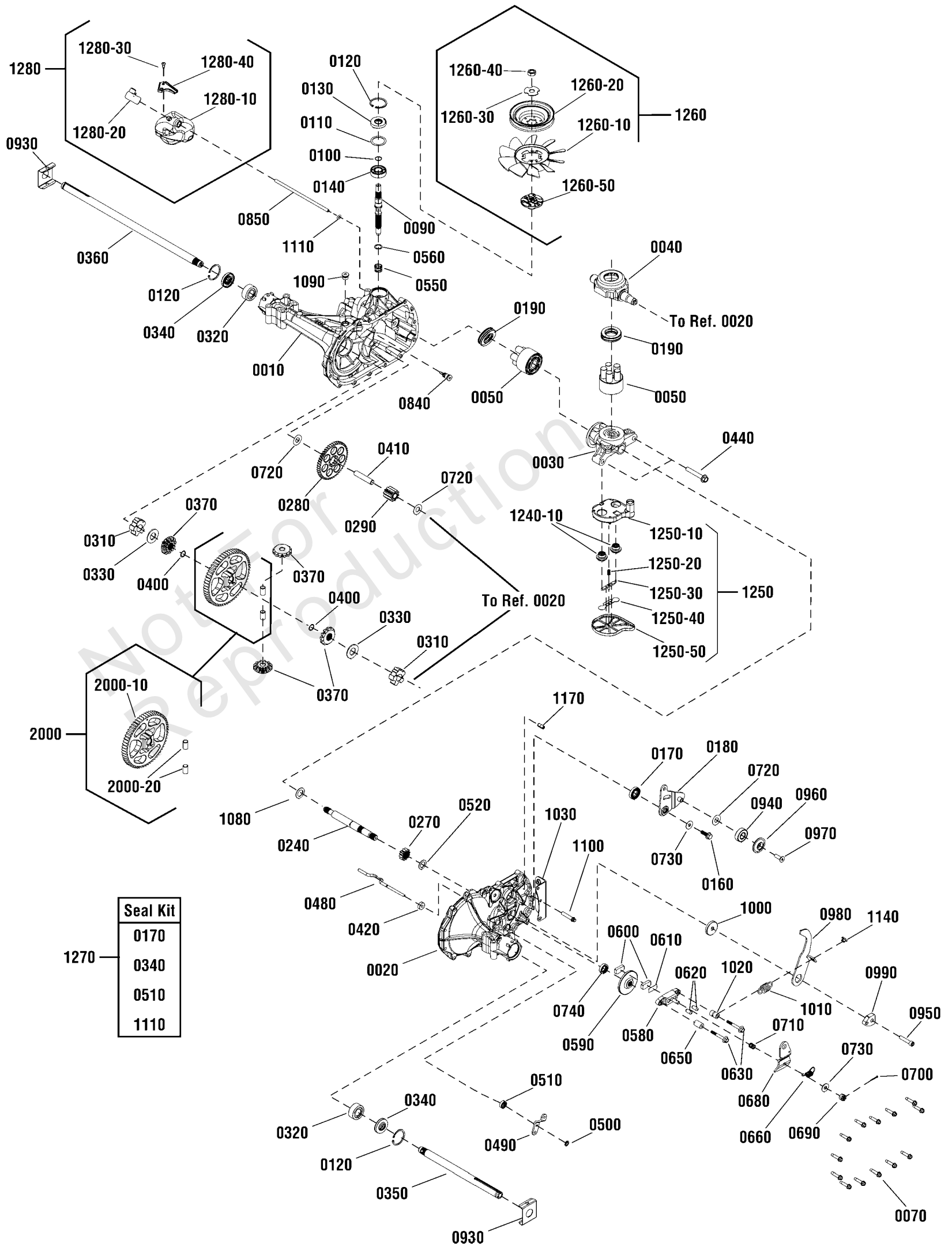

Transmission SERVICE PARTS - Hydro Gear 324-0610 (885528)

REF NO	PART NO	QTY	DESCRIPTION
0620	-----	2	* PIN, Brake Actuating
0630	-----	2	* SCREW, Hex Head, With Patch, 1/4-20 x 2
0650	1715199	1	SPACER, .26 x .57 x .87
0660	-----	1	* SPRING, Brake arm Bias
0670	1706160	1	SCREW, Square Head, Ribbed, 5/16-24
0680	-----	1	* ARM, Brake
0690	-----	1	* NUT, Castle, 5/16-24
0700	-----	1	* PIN, Cotter, 3/32 x 3/4
0710	-----	1	* SPRING, Compression Brake, Anti-Drag
0720	-----	3	* WASHER, Flat, .51 x 1.0 x .03
0730	-----	2	* WASHER, Flat, .34 x .88 x .06
0740	-----	1	* KIT, Seal
0840	-----	1	* FITTING, 5/16 SAE 5/32 TUBE
0850	-----	1	* HOSE, Expansion Tank, 7.56 In.
0930	1752466	2	SPRING CLIP, Housing Thrust (3/4" Axle)
0940	-----	1	* BEARING, Ball, .62 x 1.38 x .44
0950	-----	1	* CAPSCREW, Socket Head, 5/16-24 x 1-1/2
0960	-----	1	* SPACER, Locating
0970	-----	1	* SCREW, Countersunk, 5/16-18 x 1
0980	-----	1	* ARM, Return
0990	-----	1	* PUCK, Adjusting
1000	-----	1	* WASHER, Flat, .32 x 1.60 x .24
1010	-----	1	* SPRING, Extension, Double Loop
1020	-----	1	* SPACER, .26 x .56 x .87
1030	-----	1	* BRACKET, Torque
1080	-----	1	* WASHER, Flat, .71 x 1.16 x .04
1090	-----	1	* PLUG, 9/16-18 (METAL)
1100	-----	1	* SCREW, Torx Head, 5/16-18 x 1-1/2
1110	-----	1	* O-RING, .299 x .505 x .103 -(Not a serviceable part, order kit # 1270)
1140	-----	1	* SPRING, Guide
1170	-----	1	* PIN, Spring, .304 x .75
1240	-----	1	* CENTERSECTION ASSEMBLY, Filter, Bypass -(Not Illustrated) (Includes Ref. Nos. 0030, 1240-10 & 1250)
1240-10	-----	1	* CENTERSECTION (5-Piston) -(Not a serviceable part, order kit #1240)
1250	-----	1	* FILTER ASSEMBLY -(Includes Ref. Nos. 1250-10, 1250-20, 1250-30, 1250-40 & 1250-50)
1250-10	-----	1	* BASE, Filter, With Poppet -(Not a serviceable part, order kit #1250)
1250-20	-----	1	* SPRING, Bypass, 1/2" -(Not a serviceable part, order kit #1250)
1250-30	-----	1	* ACTUATOR, Bypass -(Not a serviceable part, order kit #1250)
1250-40	-----	1	* DEFLECTOR -(Not a serviceable part, order kit #1250)
1250-50	-----	1	* BOTTOM, Filter -(Not a serviceable part, order kit #1250)
1260	1752467	1	FAN & PULLEY KIT -(Includes Ref. Nos. 1260-10, 1260-20, 1260-30, 1260-40 & 1260-50)
1260-10	-----	1	* FAN, 7" (10 BLADE) -(Not a serviceable part, order kit #1260)

Footnotes:

Note:* See your local authorized dealership for parts and warranty or contact Hydro Gear at www.hydro-gear.com/Support/NorthAmerica.aspx (U.S. 1-877-728-7410 Int'l 32 (0) 12 670 631)

Transmission SERVICE PARTS - Hydro Gear 324-0610 (885528)

Note: Unless noted otherwise, use the standard torque specifications

Mfg. No: 2691297-01

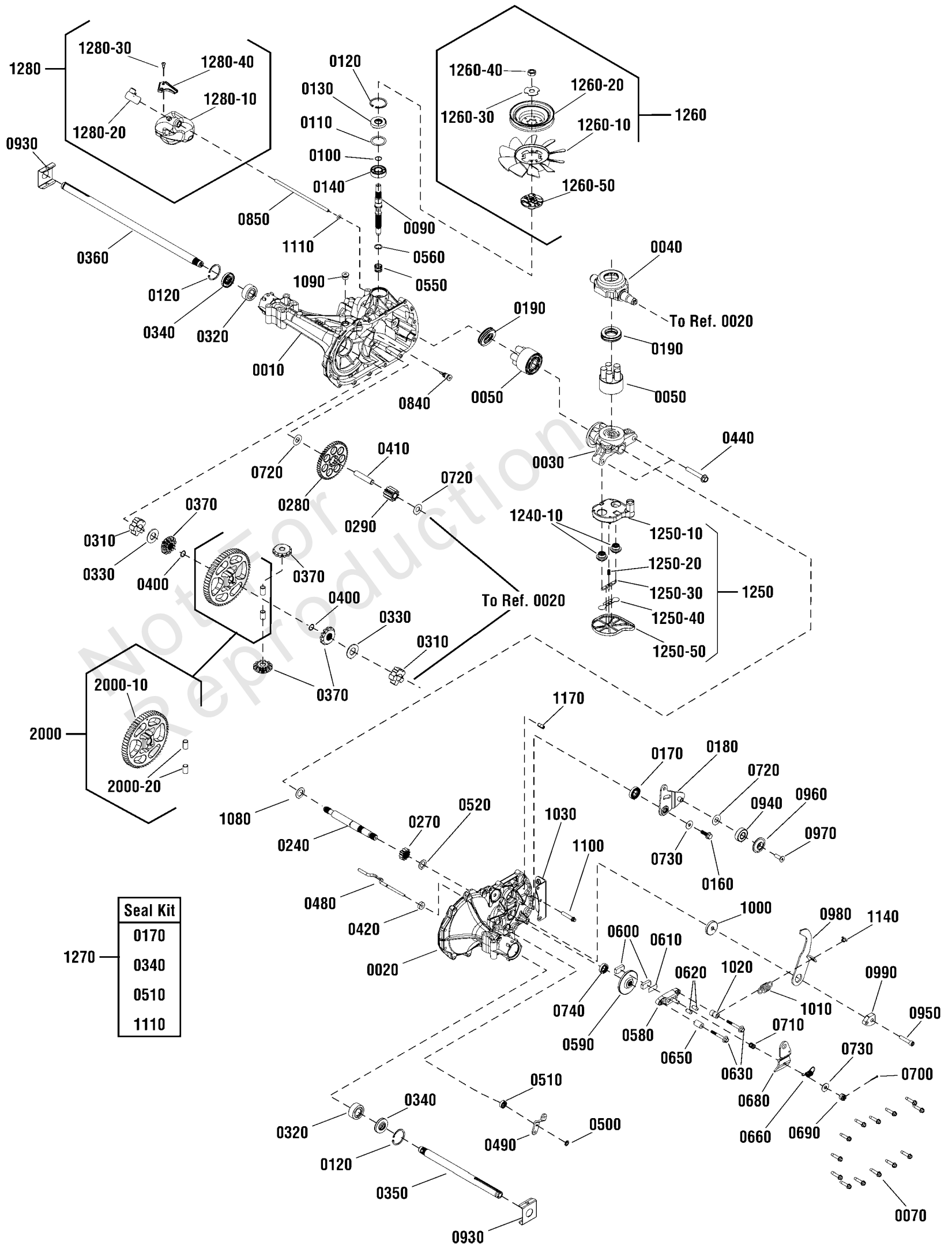

Transmission SERVICE PARTS - Hydro Gear 324-0610 (885528)

REF NO	PART NO	QTY	DESCRIPTION
1260-20	-----	1	* PULLEY, Cupped, 4-1/2" -(Not a serviceable part, order kit #1260)
1260-30	-----	1	* NUT, Hex Jam, With Patch, 1/2-20 -(Not a serviceable part, order kit #1260)
1260-40	-----	1	* WASHER, Slotted, .53 x 1.63 x .06 -(Not a serviceable part, order kit #1260)
1260-50	-----	1	* HUB, Pulley -(Not a serviceable part, order kit #1260)
1270	1752468	1	SEAL & O-RING KIT -(Includes Ref. Nos. 0170, 0340, 0510 & 1110)
1280	1752469	1	EXPANSION TANK KIT -(Includes Ref. Nos. 1280-10, 1280-20, 1280-30 & 1280-40)
1280-10	-----	1	* TANK, Expansion -(Not a serviceable part, order kit #1280)
1280-20	-----	1	* CAP, Expansion Tank -(Not a serviceable part, order kit #1280)
1280-30	-----	1	* BOLT, Self Tapping, 10-32 x 1/2 -(Not a serviceable part, order kit #1280)
1280-40	-----	1	* BRACKET, Expansion Tank -(Not a serviceable part, order kit #1280)
2000	-----	1	* KIT, 60T Bull Gear Diff Pins -(Includes Ref. Nos. 2000-10 & 2000-20)
2000-10	-----	1	* GEAR, 60T
2000-20	-----	2	* PIN, 1/2

Not For
Reproduction

Footnotes:

Note:* See your local authorized dealership for parts and warranty or contact Hydro Gear at www.hydro-gear.com/Support/NorthAmerica.aspx (U.S. 1-877-728-7410 Int'l 32 (0) 12 670 631)

Wheel & Tire Group (885914)

Note: Unless noted otherwise, use the standard torque specifications

Mfg. No: 2691297-01

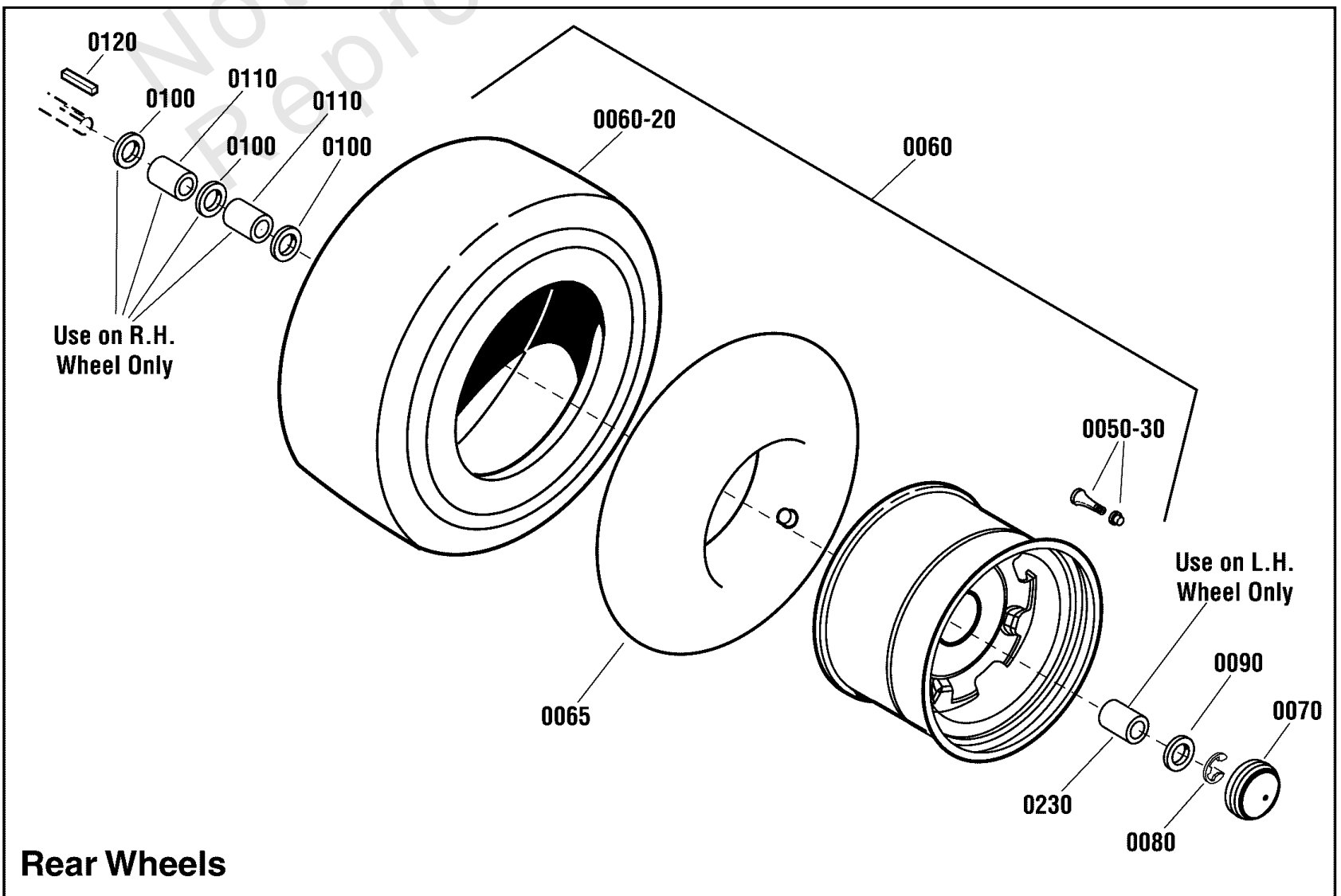
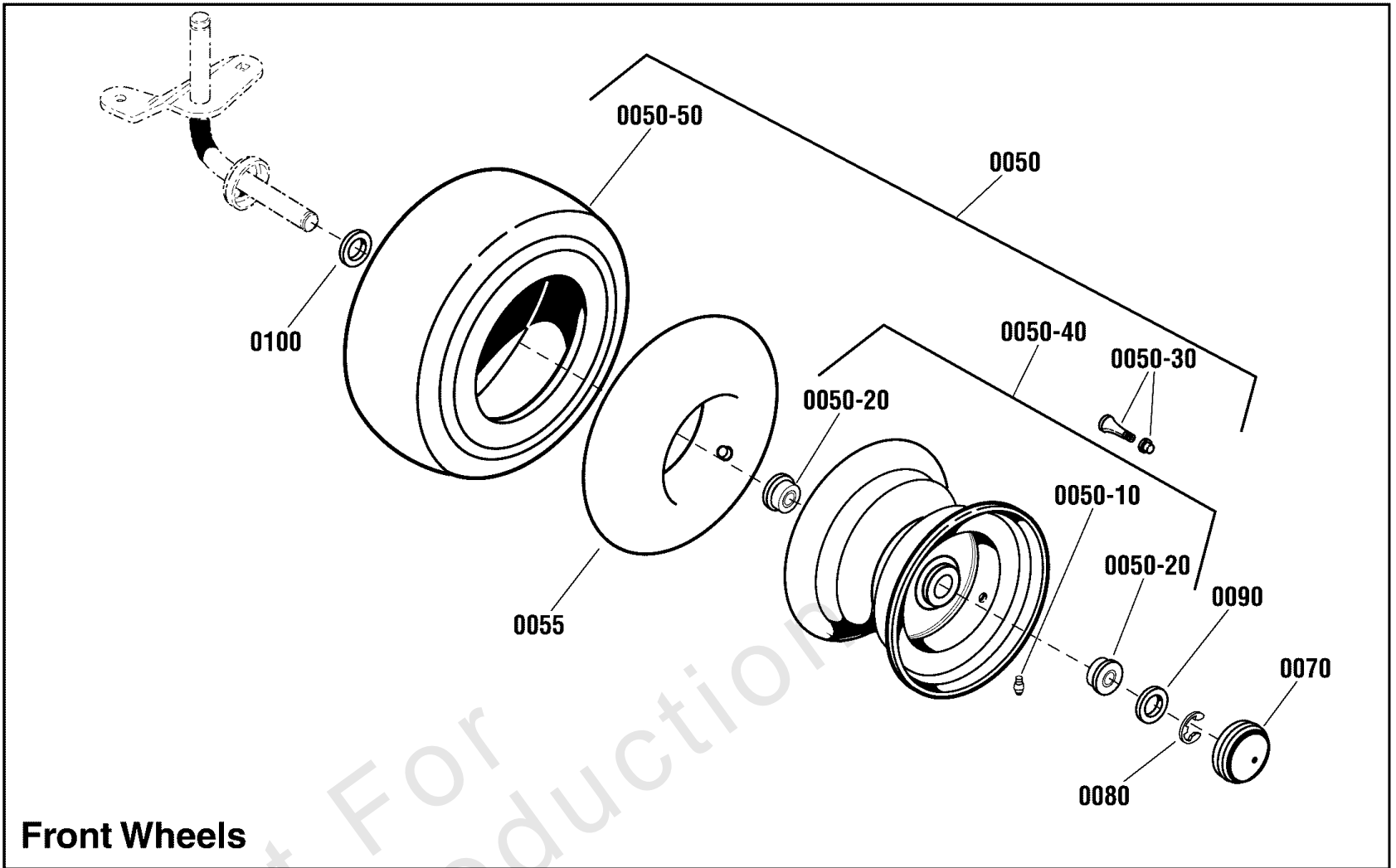

Wheel & Tire Group (885914)

REF NO	PART NO	QTY	DESCRIPTION
0050	1729708SM	2	WHEEL& TIRE ASSEMBLY, Front -(Includes Ref. Nos. 0050-10, 0050-20, 0050-30, 0050-40 & 0050-50)
0050-10	2812808SM	1	FITTING, Lube
0050-20	1713167SM	2	BEARING, 3/4
0050-30	2172353SM	4	VALVE STEM & CAP
0050-40	1726301SM	2	WHEEL & BUSHINGS ASSEMBLY, Front -(Includes Ref. Nos. 0050-10 & 0050-30)
0050-50	1731951SM	2	TIRE, Kenda, Turf Rider, Front, 15 x 6.00 - 6
0055	1664090SM	2	TUBE, Tire, Front
0060	885457YP	2	WHEEL & TIRE ASSEMBLY, Rear, 20 X 8-8 -(Includes Ref. Nos. 0050-30 & 0060-20)
0060-20	-----	2	TIRE, Rear, K358 -(Not a serviceable part, order Ref. 0060)
0065	2164247SM	2	TUBE, Tire, Rear
0070	094618MA	4	HUB CAP
0080	0011X3MA	4	E-RING
0090	1722717SM	4	WASHER, Flat
0100	17X160MA	6	WASHER, Flat, 3/4 x 1-1/4
0110	1730181SM	2	SPACER, 3/4 ID x 1-1/4 OD x 1-5/8, RH -(Use on R.H. Side Only)
0120	021553MA	2	KEY, Square, 3/16
0230	885578YP	1	SPACER, Wheel, LH -(Use on L.H. Side Only)

Not For
Reproduction

Hardware Identification & Torque Specifications

Torque Specification Chart								
FOR STANDARD METRIC MACHINE HARDWARE (Tolerance ± 20%)								
Property Class	5.6		8.8		10.9		12.9	
	Class 5.6		Class 8.8		Class 10.9		Class 12.9	
Size Of Hardware	in/lbs	Nm.	in/lbs	Nm.	in/lbs	Nm.	in/lbs	Nm.
	ft/lbs		ft/lbs		ft/lbs		ft/lbs	
M3	5.88	.56	13.44	1.28	19.2	1.80	22.92	2.15
M4	13.44	1.28	30.72	2.90	43.44	4.10	52.56	4.95
M5	26.4	2.50	60.96	5.75	5.97	8.10	7.15	9.7
M6	44.64	4.3	7.3	9.9	10.3	14	12.1	16.5
M7	5.2	7.1	12.1	16.5	16.9	23	19.9	27
M8	7.7	10.5	17.7	24	25	34	29	40
M10	15	21	35	48	50	67	59	81
M12	26	36	61	83	86.2	117	103	140
M14	42	58	101	132	136	185	162	220
M16	64	88	147	200	210	285	250	340
M18	89	121	202	275	287	390	346	470
M20	126	171	290	390	405	550	486	660
M22	169	230	390	530	559	745	656	890
M24	217	295	497	375	708	960	840	1140
M27	320	435	733	995	1032	1400	1239	1680
M30	435	590	995	1350	1401	1900	1681	2280
M33	590	800	1349	1830	1902	2580	2278	3090
M36	759	1030	1740	2360	2441	3310	2935	3980
M39	988	1340	2249	3050	3163	4290	3798	5150

Torque Specification Chart						
FOR STANDARD MACHINE HARDWARE (Tolerance ± 20%)						
Hardware Grade	No Marks		SAE Grade 5		SAE Grade 8	
	SAE Grade 2		SAE Grade 5		SAE Grade 8	
Size Of Hardware	in/lbs	Nm.	in/lbs	Nm.	in/lbs	Nm.
	ft/lbs		ft/lbs		ft/lbs	
8-32	19	2.1	30	3.4	41	4.6
8-36	20	2.3	31	3.5	43	4.9
10-24	27	3.1	43	4.9	60	6.8
10-32	31	3.5	49	5.5	68	7.7
1/4-20	66	7.6	8	10.9	12	16.3
1/4-28	76	8.6	10	13.6	14	19.0
5/16-18	11	15.0	17	23.1	25	34.0
5/16-24	12	16.3	19	25.8	29	34.0
3/8-16	20	27.2	30	40.8	45	61.2
3/8-24	23	31.3	35	47.6	50	68.0
7/16-14	30	40.8	50	68.0	70	95.2
7/16-20	35	47.6	55	74.8	80	108.8
1/2-13	50	68.0	75	102.0	110	149.6
1/2-20	55	74.8	90	122.4	120	163.2
9/16-12	65	88.4	110	149.6	150	204.0
9/16-18	75	102.0	120	163.2	170	231.2
5/8-11	90	122.4	150	204.0	220	299.2
5/8-18	100	136	180	244.8	240	326.4
3/4-10	160	217.6	260	353.6	386	525.0
3/4-16	180	244.8	300	408.0	420	571.2
7/8-9	140	190.4	400	544.0	600	816.0
7/8-14	155	210.8	440	598.4	660	897.6
1-8	220	299.2	580	788.8	900	1,244.0
1-12	240	326.4	640	870.4	1,000	1,360.0

The guides and ruler furnished below are designed to help you select the appropriate hardware.



Nut, M8

Thread Diameter (mm)

Inside Diameter (in) Threads per inch

Nut, 1/2-16

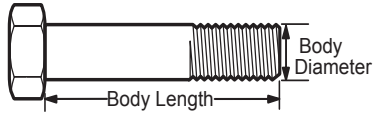

Screw, M8- 1.25 x 25

Thread Diameter (mm) Distance between threads (mm) Body Length (mm)

Body Diameter Threads per inch Body Length (in)

Screw, 1/2- 16 x 2



Standard Hardware Sizing

When a washer or nut is identified as 1/2" (M8), this is the *Nominal size*, meaning the *inside diameter* is 1/2 inch (8mm metric thread diameter); if a second number is present it represents the *threads per inch* (distance between threads).

When bolt or capscrew is identified as 1/2 - 16 x 2" (M8 - 1.25 x 50), this means the *Nominal size*, or body diameter is 1/2 inch (8mm metric thread diameter), the second number, 16, represents the *threads per inch*, (*distance between threads*). The final number is the body length of the bolt or screw, 2 inches (50mm).

NOTES

- These torque values are to be used for all hardware excluding: locknuts, self-tapping screws, thread forming screws, sheet metal screws and socket head setscrews.
- Recommended seating torque values for locknuts:
 - for prevailing torque locknuts - use 65% of grade 5 torques.
 - for flange whizlock nuts and screws - use 135% of grade 5 torques.
- Unless otherwise noted on assembly drawings, all torque values must meet this specification.

Common Hardware Types

Hex Head Capscrew



Washer



Carriage Bolt



Hex Nut

Wrench & Fastener Size Guide

1/4" Bolt or Nut Wrench—7/16"	5/16" Bolt or Nut Wrench—1/2"	3/8" Bolt or Nut Wrench—9/16"	7/16" Bolt or Nut Wrench (Bolt)—5/8" Wrench (Nut)—11/16"	1/2" Bolt or Nut Wrench—3/4"
M6 Bolt or Nut Wrench—10mm	M8 Bolt or Nut Wrench—13mm	M10 Bolt or Nut Wrench—17mm	M12 Bolt or Nut Wrench—19mm	M14 Bolt or Nut Wrench—22mm

