

ECHO®

shindaiwa®

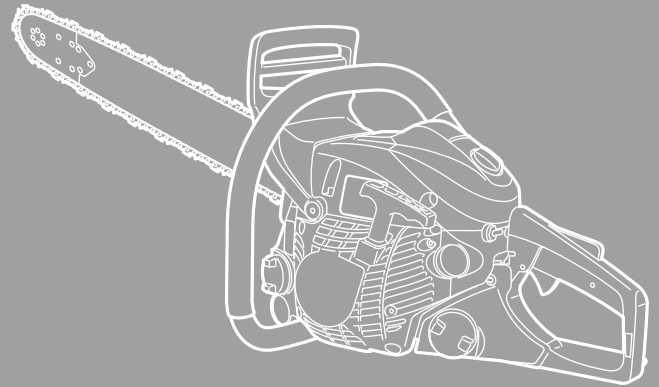

SERVICE MANUAL

ECHO: CS-501SX
CS-501SXH

shindaiwa: 501sx

(Serial number: 3700001 and after)

(Serial number: 3800001 and after)

INTRODUCTION

This service manual contains information for service and maintenance of **ECHO CHAIN SAW**, model **CS-501SX, CS-501SXH**, **shindaiwa CHAIN SAW**, model **501sx**.

For systematic diagnosis, to avoid extra work, time loss and to meet Emission regulation, please refer to “Troubleshooting guide” that describes problems, testing, remedies and references. We recommend you make use of Operator’s Manual and Parts Catalogue together with this manual when servicing.

We are constantly working on technical improvement of our products. For this reason, technical data, equipment and design are subject to change without notice. All specifications, illustrations and directions in this manual are based on the latest product information available at the time of publication.

NOTE: This service manual contains pictures with different model name for other markets and different colored model.

	Page		Page
1 SERVICE INFORMATION	2	5 CLUTCH SYSTEM	36
1-1 Specifications	2	5-1 Inspectng clutch parts	37
1-2 Technical data	3	5-2 Replacing clutch parts	38
1-3 Torque limits	4	5-3 Installing clutch assembly.....	38
1-4 Special repairing materials.....	4		
1-5 Service Limits	5	6 CHAIN BRAKE SYSTEM	40
1-6 Special tools	6	6-1 Disassembling chain brake	41
		6-2 Assembling brake parts.....	42
2 STARTER SYSTEM	7		
2-1 Disassembling starter assembly.....	8	7 SAW CHAIN LUBRICATION SYSTEM	43
2-2 Replacing starter rope	9	7-1 Inspecting oil cap and strainer.....	44
2-3 Assembling starter.....	10	7-2 Inspecting auto-oiler assembly and oil line....	45
2-4 Replacing starter pawl.....	12	7-3 Inspecting oil tank vent.....	46
3 IGNITION SYSTEM	13	8 ENGINE	47
3-1 Troubleshooting guide.....	14	8-1 Testing cylinder compression	48
3-2 Testing spark	15	8-2 Cleaning cooling air passages	48
3-3 Inspecting spark plug	15	8-3 Inspecting muffler and exhaust port	49
3-4 Inspecting ignition switch.....	16	8-4 Testing crankcase and cylinder seal.....	50
3-5 Replacing ignition switch	16	8-5 Inspecting cylinder.....	51
3-6 Inspecting ignition coil resistance.....	17	8-6 Inspecting piston and piston ring.....	52
3-7 Replacing spark plug cap and coil.....	18	8-7 Replacing oil seal	53
3-8 Replacing ignition coil.....	18	8-8 Disassembling crankcase.....	54
3-9 Setting pole shoe air gaps.....	19	8-9 Replacing ball bearing and oil seal.....	54
3-10 Inspecting flywheel and key	19	8-10 Assembling crankshaft and crankcase.....	55
		8-11 Installing piston.....	56
4 FUEL SYSTEM	21	8-12 Installing piston ring and cylinder	57
4-1 Inspecting air filter	22		
4-2 Inspecting fuel cap and fuel strainer.....	22	9 REAR HANDLE AND CONTROL SYSTEM	58
4-3 Inspecting fuel tank and line.....	23	9-1 Replacing cushions	59
4-4 Inspecting and replacing tank vent.....	24	9-2 Replacing throttle trigger	61
4-5-1 Replacing fuel line	26	9-3 Service hint for heated handle (CS-501SXH only) ...	63
4-5-2 Replacing fuel vent pipe	27	9-3-1 Inspecting heated handle	64
4-6 Adjusting carburetor	28	9-3-2 Replacing stator assembly	66
4-6-1 General adjustment rules	28	9-3-3 Replacing rear handle heater	67
4-6-2 Initial setting Throttle adjust screw, L mixture needle and H mixture needle	28	9-3-4 Replacing heater switch	69
4-6-3 Adjusting carburetor	29		
4-7 Air shutter.....	30	10 GUIDE BAR MOUNTING SYSTEM	70
4-8 Testing carburetor.....	31	10-1 Replacing chain tensioner	71
4-9 Inspecting crankcase pulse passage	32	10-2 Replacing guide bar stud.....	71
4-10 Inspecting metering lever height	32	10-3 Installing guide bar stud	72
4-11 Inspecting inlet needle valve	33		
4-12 Inspecting diaphragm	33	11 MAINTENANCE GUIDE	73
4-13 Replacing Welch plug.....	34	11-1 Disassembly Chart	73
4-14 Installing carburetor.....	35	11-2 Troubleshooting guide	74
		11-3 Service Intervals.....	76

1 SERVICE INFORMATION

1-1 Specifications

Models		CS-501SX, 501sx	CS-501SXH
Dimensions	Length*	mm(in)	395 (15.6)
	Width	mm(in)	235 (9.3)
	Height	mm(in)	290 (11.4)
Dry weight*		kg(lb)	4.7 (0.2) 4.9 (10.8)
Engine	Type	YAMABIKO, air-cooled, two-stroke, single cylinder	
	Rotation	Clockwise as viewed from the output end	
	Displacement	cm ³ (in ³)	50.2 (3.063)
	Bore	mm(in)	44.0 (1.732)
	Stroke	mm(in)	33.0 (1.299)
	Compression ratio	7.2	
Carburetor	Type	Diaphragm horizontal-draft	
	Model	Walbro WT-1139	
	Venturi size-Throttle bore	mm(in)	13.5 - 15.85 (0.531 - 0.624)
Ignition	Type	CDI (Capacitor discharge ignition) system	
	Spark plug	NGK BPMR8Y	
Exhaust	Muffler type	Spark arrester muffler	
Starter	Type	Automatic Rewind	
	Rope diameter x length	mm(in)	3.8 x 910 (0.15 x 35.8)
Fuel	Type**	Mixed two-stroke fuel	
	Mixture ratio	50 : 1 (2 %)	
	Gasoline	Minimum 89 octane petrol	
	Two-stroke air cooled engine oil	ISO-L-EGD (ISO/CD13738), JASO FC/FD	
	Tank capacity	L (U.S.fl.oz.)	0.5 (16.9)
Clutch	Type	Centrifugal type	
Guide bar / Saw chain lubrication type		Automatic with volume adjuster	
Oil	Tank capacity	L (U.S.fl.oz.)	0.28 (9.5)
Auto oiler	Type	Clutch driven type	
Sprocket	Type	Floating rim	
	Number of teeth	7	
	Pitch	in	0.325
Heated handle		---	Equipped

* Without guide bar and saw chain.

** Premixed alkylate fuel for 2-stroke can be used.

Cutting devices				
Guide bar	Type	V40R21-68AA	V45R21-72AA	V50R21-80AA
	Called length	cm	40	45 50
	Gauge	in	0.058	
Saw chain	Type	Oregon 21BPX, Carlton K2L		
	Number of drive links	68	72	80
	Pitch	in	0.325	
	Gauge	in	0.058	

1-2 Technical data

Models	CS-501SX, 501sx	CS-501SXH
Engine		
Compression pressure	MPa (kgf/cm ²) (psi) 0.95 (9.7) (138)	
Clutch engagement speed	r/min 3,900	
Ignition system		
Spark plug gap	mm(in) 0.6 - 0.7 (0.024 - 0.028)	
Spark test	Tester gap w/ spark plug	mm(in) 4.0 (0.16)
	Tester gap w/o spark plug	mm(in) 6.0 (0.24)
Secondary coil resistance	kΩ 2.5 - 2.9	
Pole shoe air gaps	mm(in) 0.3 - 0.4 (0.012 - 0.016)	
Ignition timing	at 3,000 r/min	°BTDC 20
	at 8,000 r/min	°BTDC 32
	at 10,000 r/min	°BTDC 34
Carburetor		
Test Pressure, minimum	MPa (kgf/cm ²) (psi) 0.05 (0.5) (7.0)	
Metering lever height	mm(in) 1.65 (0.06) lower than diaphragm seat	
Tool to adjust mixture needles	D-shaped tool (L) P/N X645-000031 (Carb. adjustment tool P/N Y089-000094)	
Carburetor adjustment		
Before carburetor adjustment :		
	---	Turn off heater switch.
1) Initial setting	H mixture needle	turn out 3 5/8
	L mixture needle	turn out 1 3/4
	Throttle adjust screw	turn in*1 2 1/8
Engine warm-up	Idle - WOT : Total	sec. 5 - 5 : 100
2) Find idle maximum speed	Adjust L mixture needle to maximum idle speed*2	
3) Set idle maximum speed w/ TAS	r/min	3,500
4) Set idle speed by turning L mixture needle CCW	r/min	2,700
5) Confirm H mixture needle position before WOT setting	Turn H mixture needle CCW to confirm engine speed decreases less than or equal to 12,500 r/min.	
6) WOT setting	r/min	Turn H mixture needle CW in 1/8 turn increments with the engine at idle, then accelerate to WOT and check engine speed. The final engine speed should fall within: 13,000 - 13,800
7) Verify final engine speed with standard equipment		Idle: 2,300 - 3,100
	r/min	WOT: 13,000 - 13,800
8) Verify clutch engagement speed	Confirm clutch engagement speed. If it is less than 1.25 times the idle speed, adjust the idle speed by turning TAS CCW.	
Chain oil discharge volume at 7,000 r/min	mL/min (US.fl.oz./min) Ajustable: 3.0 - 16.5 (0.12 - 0.65) (Factory set: 7 mL/min)	

BTDC: Before top dead center **WOT:** Wide open throttle **CCW:** Counterclockwise **TAS:** Throttle adjust screw

*1 Set Throttle adjust screw to the point that its tip just contacts throttle plate before initial setting.

*2 If chain starts to rotate during adjustment process step 2), decrease engine speed by turning TAS CCW until chain stops and then redo step 2). Repeat this until chain no longer rotates after the adjustment step 2).

1-3 Torque limits

Descriptions		Size	kgf•cm	N•m	in•lbf	
Starter system	Starter pawl	M5	90 - 120	9 - 12	80 - 105	
	Starter case	M4	20 - 30	2 - 3	18 - 25	
Ignition system	Magneto rotor (Flywheel)	M8	150 - 170	15 - 17	130 - 150	
	Ignition coil	M4	30 45	3 4.5	25 40	
	Igniton switch	M10	20 - 30	2 - 3	18 - 25	
	Spark plug	M14	130 - 170	13 - 17	113 - 150	
Fuel system	Carburetor	M5	20 - 30	2 - 3	18 - 25	
	Carburetor elbow	M4	20 - 30	2 - 3	18 - 25	
Clutch	Clutch shoe	LM10	280 - 300	28 - 30	245 - 265	
	Clutch drum	M8	150 - 170	15 - 17	130 - 150	
Engine	Crankcase	M5	70 - 90	7 - 9	60 - 80	
	Muffler	M5	70 - 90	7 - 9	60 - 80	
	Cylinder	M5	70 - 90	7 - 9	60 - 80	
	Cylinder cover	M4	25 - 35	2.5 - 3.5	22 - 30	
Others	Auto-oiler	M4	20 - 35	2 - 3.5	18 - 30	
	Oiler cover	M4	30 - 45	3 - 4.5	25 - 40	
	Crankcase (at oil tank)	M5	50 - 70	5 - 7	45 - 60	
	Cushion (on Front handle)	M5	20 - 30	2 - 3	18 - 25	
	Front handle	M5	40 - 55	4 - 5.5	35 - 48	
		M4	30 - 45	3 - 4.5	25 - 40	
	Rear handle assembly	(M side)	M5	40 - 55	4 - 5.5	35 - 48
		(D side)	M5	40 - 55	4 - 5.5	35 - 48
	Handle grip	M4	20 - 30	2 - 3	18 - 25	
	Brake lever	(D side)	M5	40 - 60	4 - 6	35 - 40
		(M side)	M5	50 - 70	5 - 7	45 - 60
	Brake cover	M4	10 - 20	1 - 2	9 - 18	
	Washer (at brake band)	M4	15 - 25	1.5 - 2.5	13 - 22	
	Sprocket guard plate	M4	10 - 15	1 - 1.5	9 - 13	
	Guide bar nut	M8	200 - 230	20 - 23	175 - 200	
	Chain catcher	M5	50 - 70	5 - 7	45 - 60	
	Spike	M5	50 - 70	5 - 7	45 - 60	
Regular bolt, nut, and screw	M3	6 - 10	0.6 - 1	5 - 9		
	M4	15 - 25	1.5 - 2.5	13 - 22		
	M5	25 - 45	2.5 - 4.5	22 - 40		
	M6	45 - 75	4.5 - 7.5	40 - 65		

LM: Left-hand thread

1-4 Special repairing materials

Material	Location	Remarks
Adhesive	Cushion	Loctite #406 (424) or equivalent
Grease	Auto-oiler worm	EPNOC AP2 (Lithium based grease) P/N X695-000060
	Clutch needle bearing	
	Choke knob	
	Oil seal inner lips	
	Chain brake (metal contact part)	
	Throttle rod	
	Bevel gear, Screw, Chain tensioner	

1-5 Service Limits

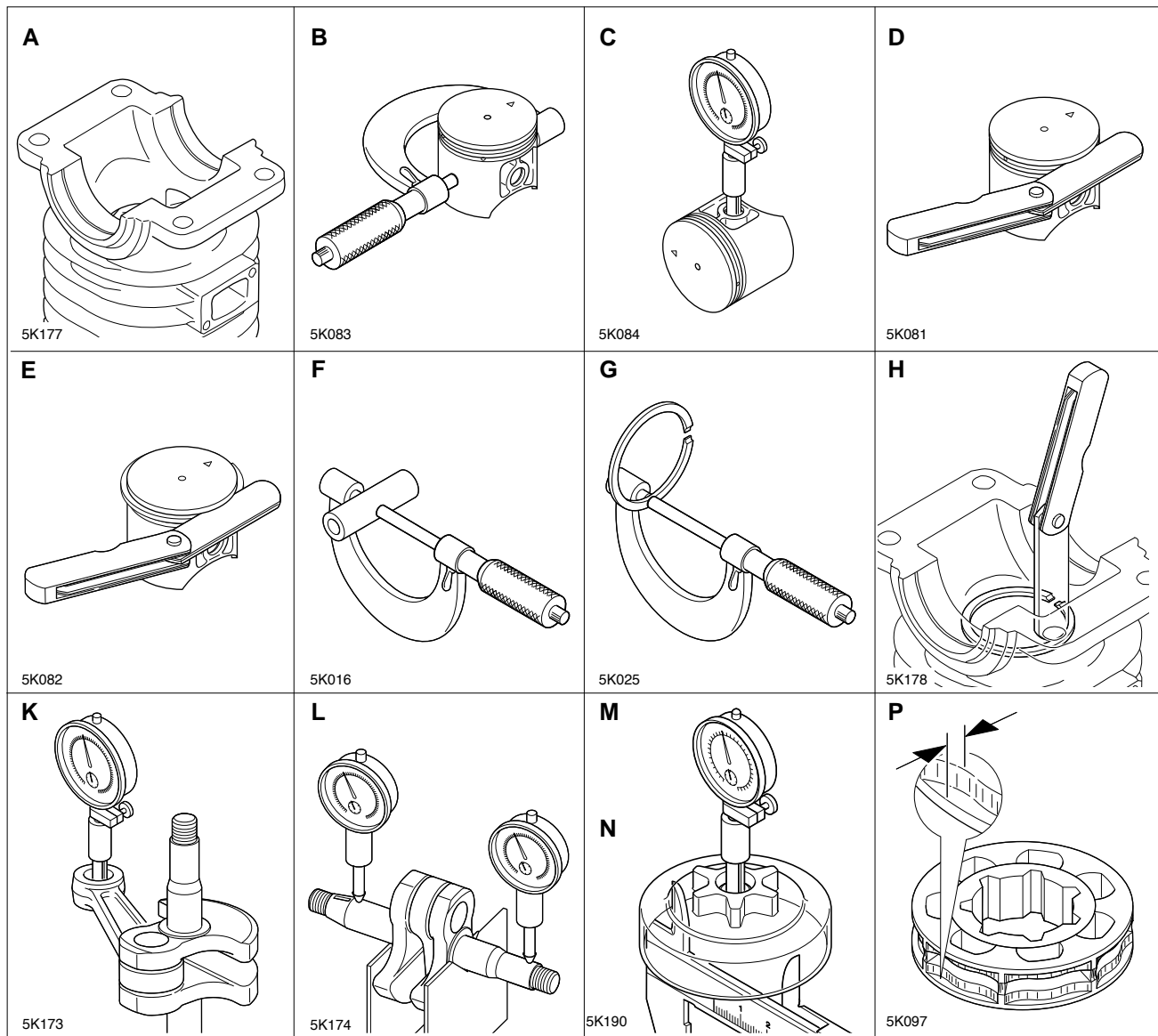

Description			mm (in)	
A	Cylinder bore		When plating is worn and aluminium can be seen	
B	Piston outer diameter	Min.	43.87	(1.727)
C	Piston pin bore	Max.	11.025	(0.4341)
D	Piston ring groove	Max.	1.6	(0.063)
E	Piston ring side clearance	Max.	0.1	(0.004)
F	Piston pin outer diameter	Min.	10.98	(0.4323)
G	Piston ring width	Min.	1.45	(0.057)
H	Piston ring end gap	Max.	0.8	(0.03)
K	Con-rod small end bore	Max.	15.025	(0.5915)
L	Crankshaft runout	Max.	0.02	(0.001)
M	Sprocket bore	Max.	12.75	(0.5020)
N	Clutch drum bore	Max.	73.5	(2.89)
P	Sprocket wear limit	Max.	0.5	(0.02)

1-6 Special tools

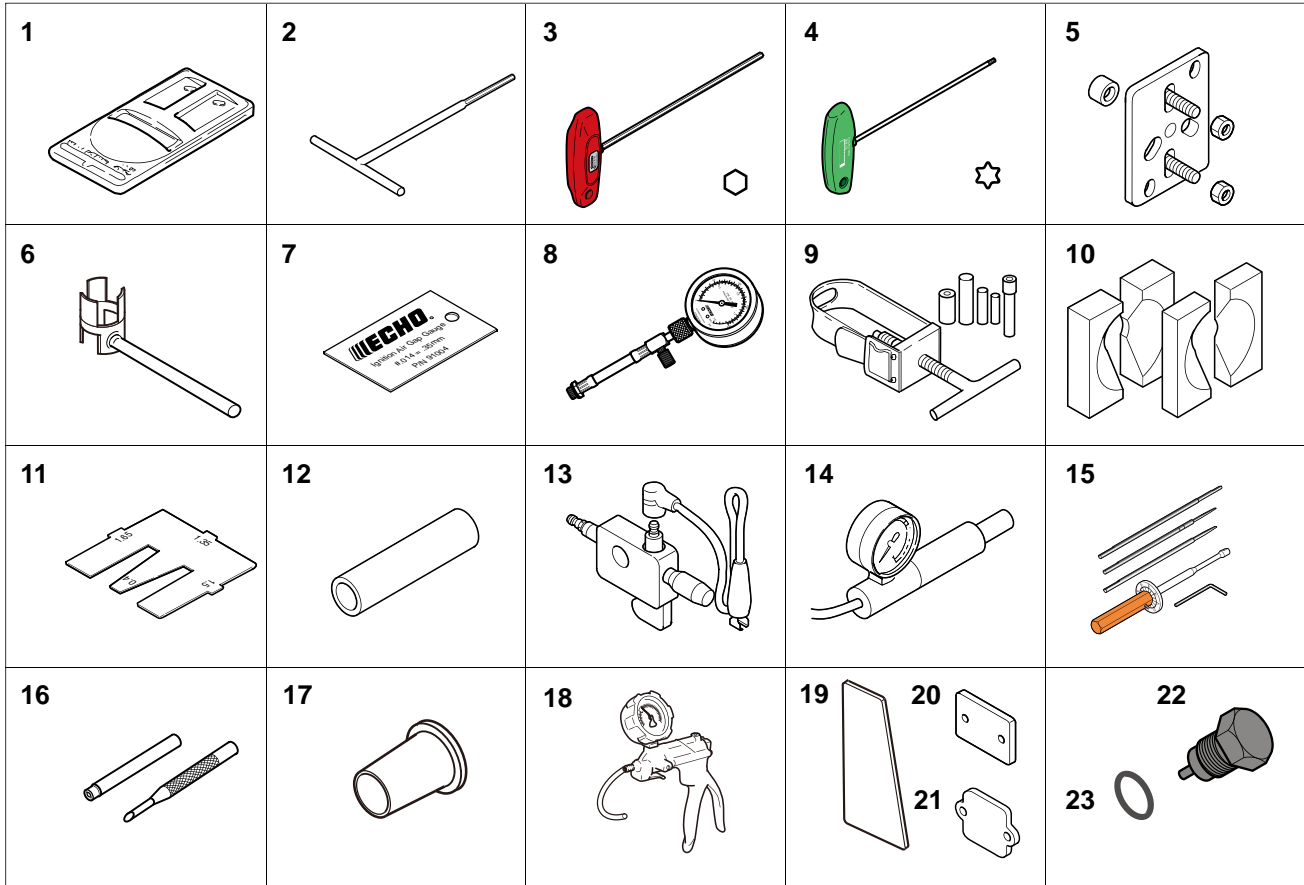

Key	Part Number	Description	Reference
1	897802-33330	Tachometer PET-1000R	Measuring engine speed to adjust carburetor
2	897559-02831	T-hex. wrench (4 mm)	Removing and installing hex. socket bolt (M5)
3	X602-000230	T-hex. wrench (5 mm)	Removing and installing hex. socket bolt (M6)
4	X602-000340	Torx wrench (T27)	Removing and installing torx bolt
5	Y089-000111	Puller	Removing magneto rotor (flywheel) and crankcase
6	X640-000370	Clutch spanner	Removing and installing clutch assembly
7	91004	Module air gap gauge	Adjusting pole shoe air gaps
8	91037	Compression gauge	Measuring cylinder compression
9	897702-30131	Piston pin tool	Removing and installing piston pin
10	897701-02830	Bearing wedge	Removing ball bearings on crankshaft
11	897563-19830	Metering lever gauge	Measuring metering lever height on carburetor
12	X646-000360	Oil seal tool	Installing oil seals and clutch plate
13	897800-79931	Spark tester	Checking ignition system
14	897803-30133	Pressure tester	Testing carburetor and crankcase leakage
15	Y089-000094	Carburetor adjustment tool	Adjusting carburetor
16	500-500	Welch plug tool (Walbro)	Removing and installing welch plug
17	X646-000150	Collar oil seal tool	Set oil seal collect position
18	91149	Pressure / vacuum tester	Testing crankcase / cylinder leakages
19	91041	Pressure rubber plug	Plugging exhaust port to test crankcase/cylinder leakages
20	897826-16131	Pressure rubber plug	Plugging intake port to test crankcase/cylinder leakages
21	897827-16131	Pressure plate	Plugging intake port to test crankcase/cylinder leakages
22	101115-37531	Plug	Testing crankcase / cylinder leakages
23	900720-00009	O-ring	Testing crankcase / cylinder leakages

2 STARTER SYSTEM

- (A) Starter case
- (B) Rope guide
- (C) Starter grip
- (D) Rewind spring
- (E) Rewind spring case
- (F) Rope reel
- (G) Starter rope
- (H) Fan cover
- (J) Starter pawl
- (K) Flywheel
- (L) Needle grommet

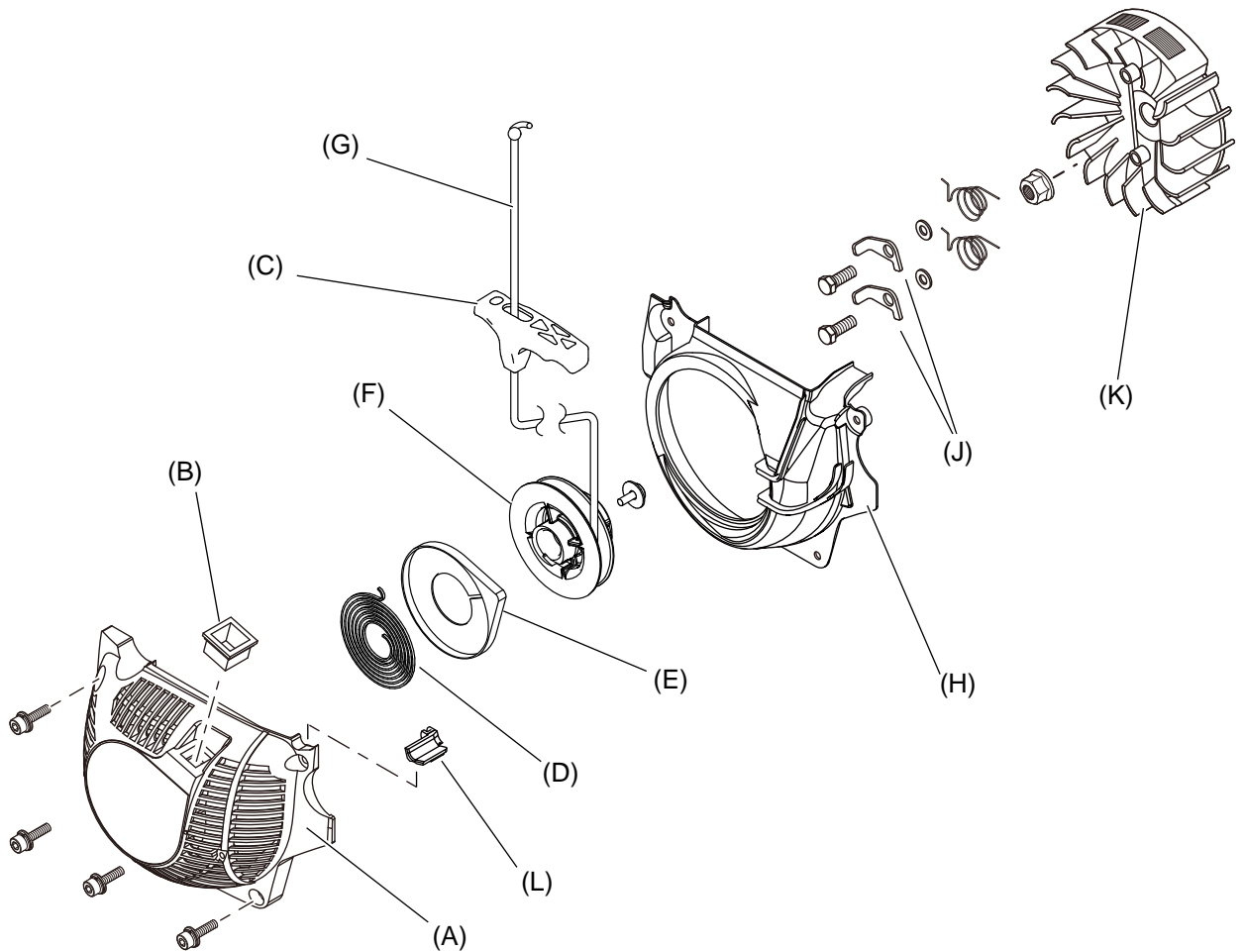

2-1 Disassembling starter assembly



1. Remove four screws and remove starter assembly (A) from unit.

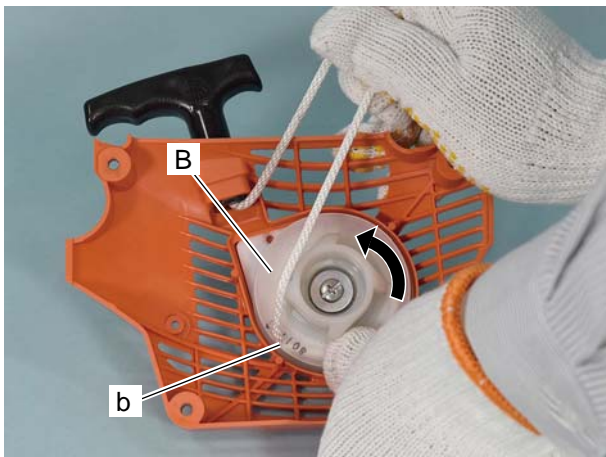

2. Pull out starter rope about 30 cm (12 in) and hold rope reel (B) by hand. Loop excess rope in rope reel notch (b) as shown.

3. Rotate rope reel (B) counterclockwise to release tension of rewind spring.

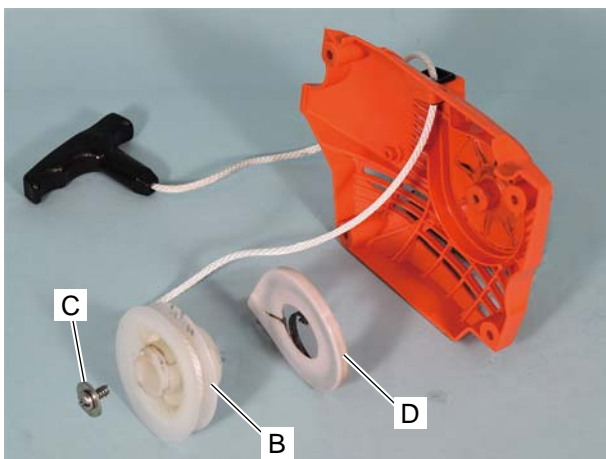

4. Remove bolt (C).

5. Remove rope reel (B) and rewind spring case (D) with rewind spring.

6. Carefully remove rewind spring and case (D) as one piece. Rewind spring is under tension and may release unexpectedly.

WARNING  **DANGER**

Wear eye protection and take care when removing starter drum. Rewind spring may unwind suddenly and cause personal injury.

2-2 Replacing starter rope

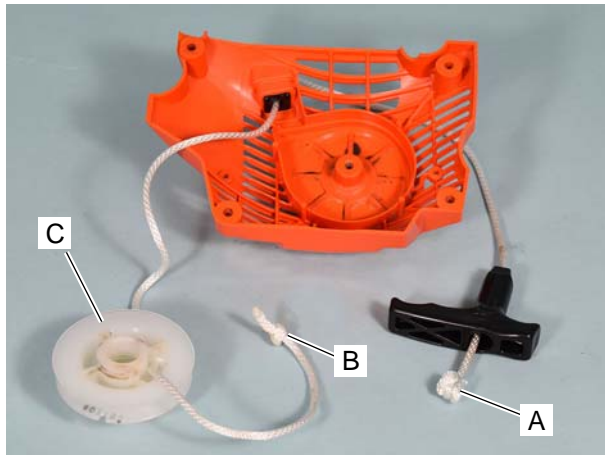

1. Pull out and untie knot (A).
2. Pull knot (B) to remove rope from rope reel (C).

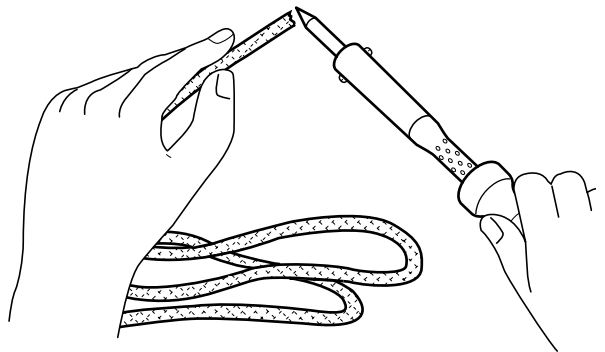

3. When installing a new starter rope, singe both ends of the rope to prevent fraying.

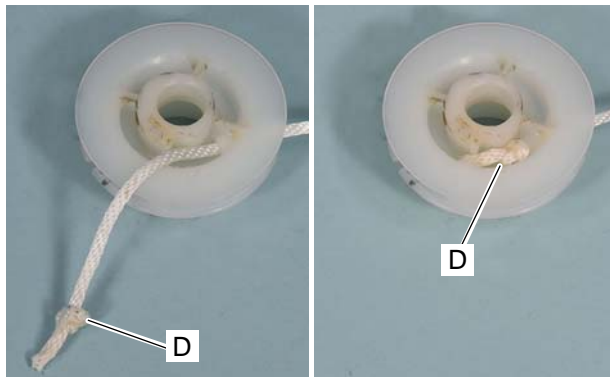

4. Make a knot (D) at end of starter rope and pass the rope through hole of rope reel, then press the knot (D) into recess as shown.

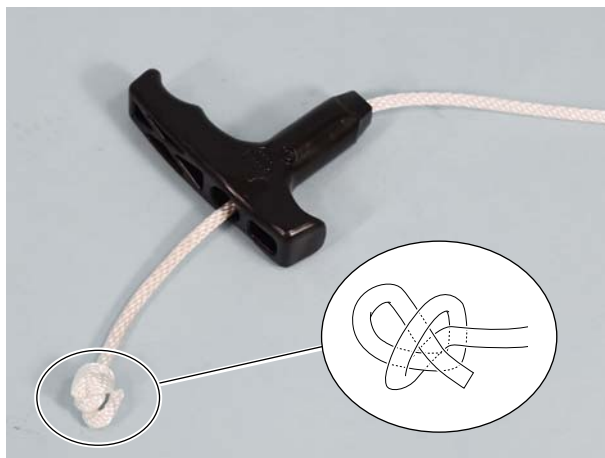

5. Pass the other end of starter rope through rope guide on starter case, then pass starter rope through starter grip and make a knot as shown.
6. Tighten knot. Push knot into recess of starter grip.

2-3 Assembling starter



1. If rewind spring (A) is removed from spring case (B), rewind inside case as shown.

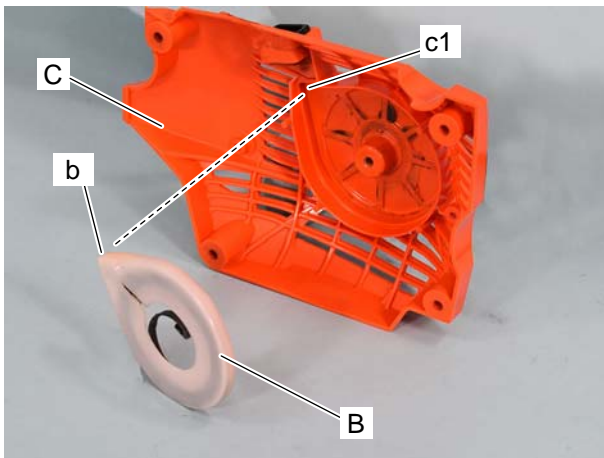

2. Carefully install rewind spring and case (B) on starter case (C) as one piece. Match ear (b) and with ear (c1) on starter case.

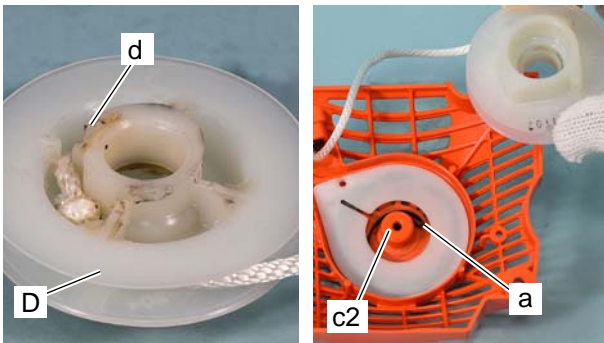

3. Assemble rope reel (D) engaging hook (d) with hook (a) of rewind spring.

NOTE: Apply lithium based grease, ECHO XTended Protection Lubricant or Red Armor Lubricant on around startet shaft (c2) of starter case (C) if dry.

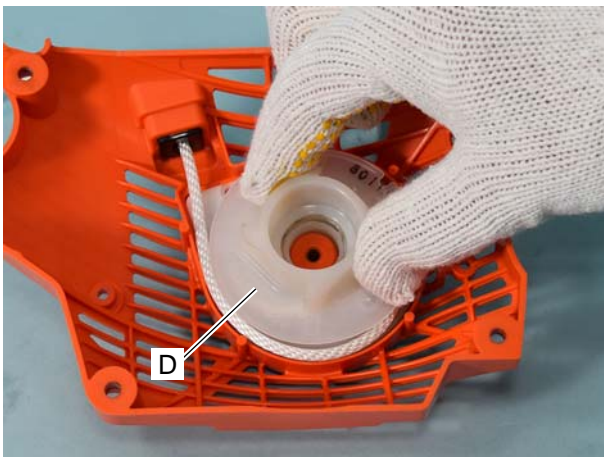

4. Check for proper engagement of rewind spring and rope reel by turning rope reel (D) clockwise and counterclockwise.

2-3 Assembling starter (continued)

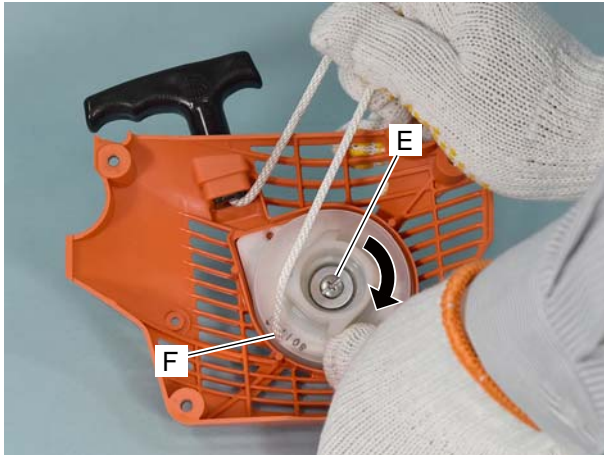

5. Reinstall bolt (E) on starter post.

6. Pull out starter rope inside starter case. Rotate rope reel clockwise several turns with starter rope hooked at notch (F) as shown. Hold rope reel to prevent it from unwinding and pull out starter grip to take the rope slack.



7. Pull starter several times to check rewind spring tension. If starter is not rewinding fully, increase spring tension by rotating rope reel one more turn clockwise following above step (6).

8. Pull out starter rope all the way, and check that rope reel can be rotated an additional half or more turn clockwise as shown, to prevent rewind spring from breaking.

9. If rope reel can not be turned clockwise, reduce tension by rotating rope reel counterclockwise one turn with starter rope hooked at notch (F).

2-4 Replacing starter pawl

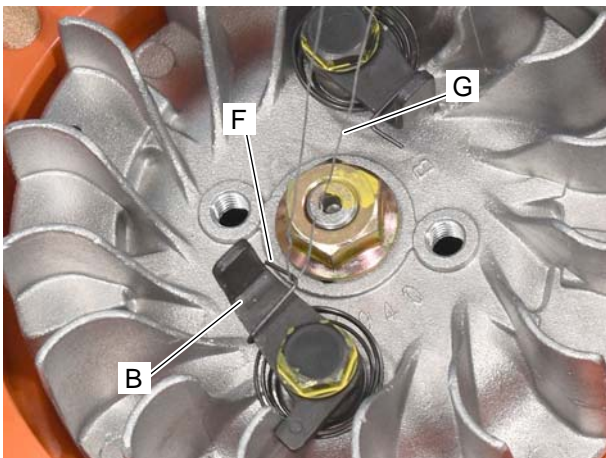
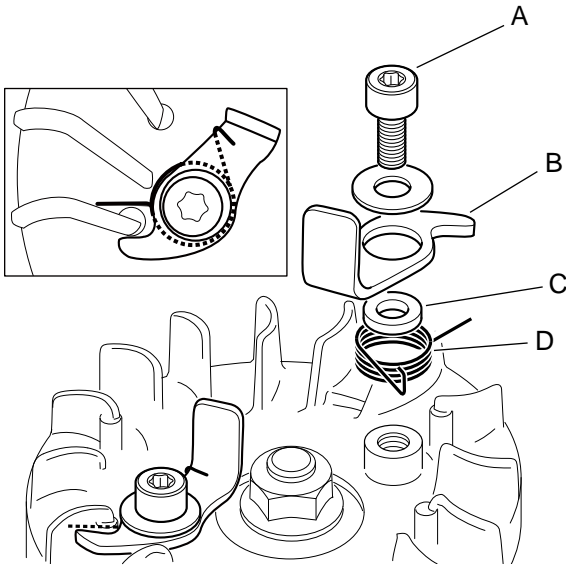

1. Remove starter assembly from unit.

2. Loosen bolt (A) and remove washer, pawl (B), spacer (C) and torsion spring (D). Replace damaged or worn parts.

NOTE: When it is hard to loosen bolt, install clean rope (E) in spark plug hole to stop crankshaft rotation and remove bolt easily.

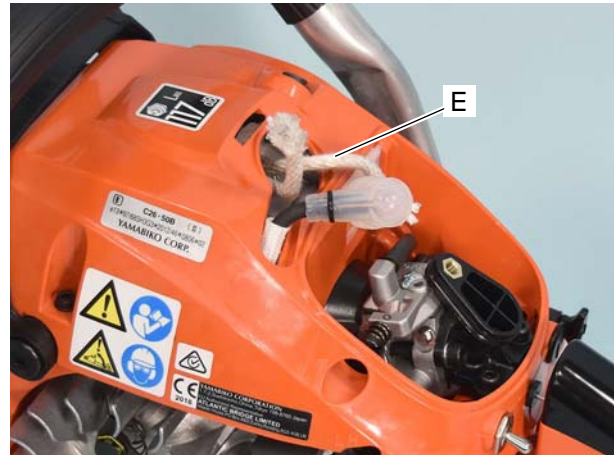

3. Install torsion spring, spacer, pawl, washer and bolt. To avoid pinching of torsion spring, install these parts without setting the end (F) of torsion spring on starter pawl. The bolt is pre-coated with sealant on the thread. If the sealant is peeled off, apply thread locking sealant (Loctite #242, Three-Bond #1324 or equivalent).

4. Using fine wire (G) or appropriate tool, place the end (F) of torsion spring on pawl (B), by hooking and passing under pawl as shown. Remove fine wire or tool.

5. Make sure pawl can move smoothly. If it does not move smoothly, check parts for correct installation.

3 IGNITION SYSTEM

- (A) Flywheel
- (B) Ignition coil
- (C) Spark plug
- (D) Spark plug cap coil
- (E) Spark plug cap
- (F) Switch lead
- (G) Ignition switch

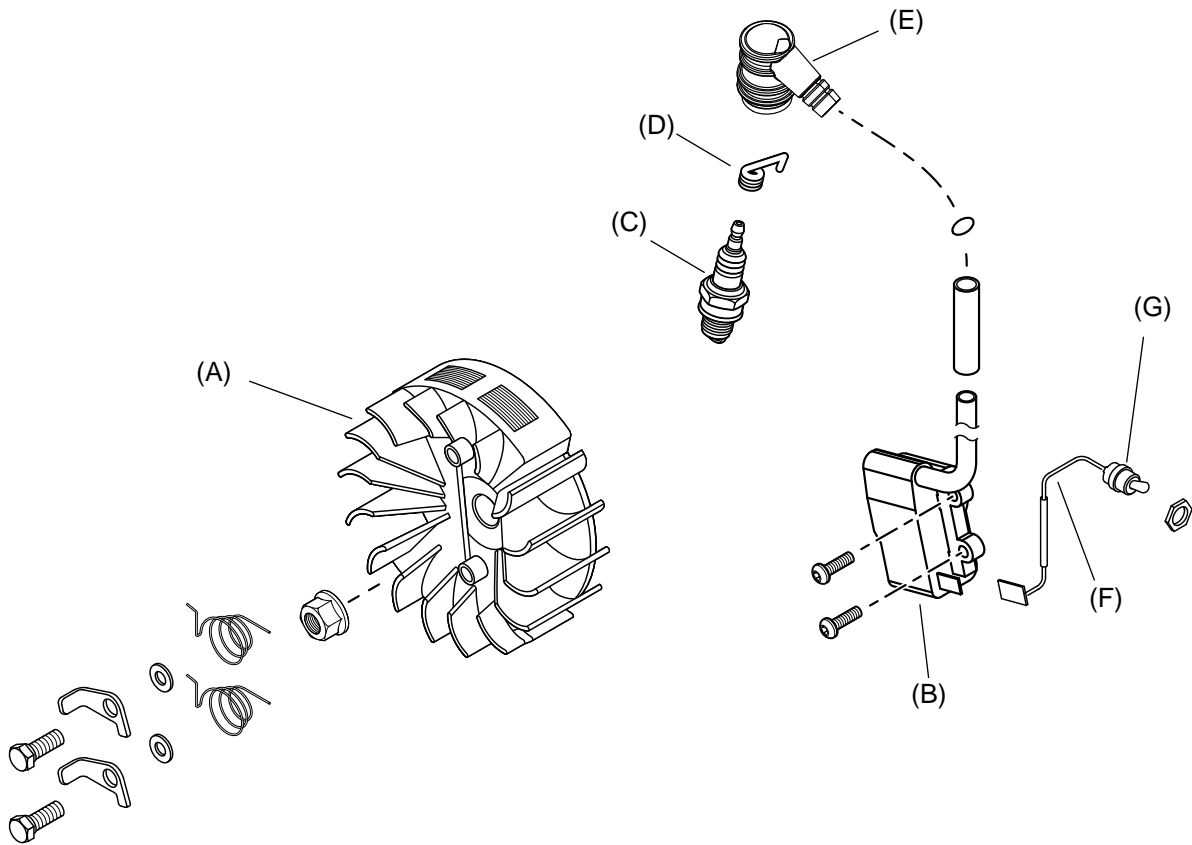

3-2 Testing spark

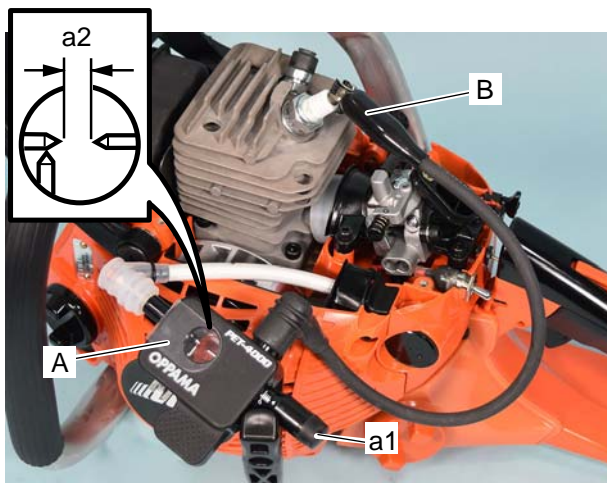

1. Remove cleaner lid, air filter and cylinder cover. Remove spark plug cap from spark plug.
2. Connect Spark tester 897800-79931 (A) to high tension lead and connect tester lead (B) on spark plug.
3. Screw in adjuster (a1) until the needle tips contact. Turn out adjuster (a1) 4 turns to set spark tester gap (a2) to 4 mm (0.16 in).
4. Turn ignition switch to "I" position. Pull starter grip several times.
5. If spark is steady blue or white at the tester gap, ignition system is considered good. Go to inspecting spark plug.
6. If no spark exists or spark is intermittent in yellow, orange, or red, continue with further inspection.

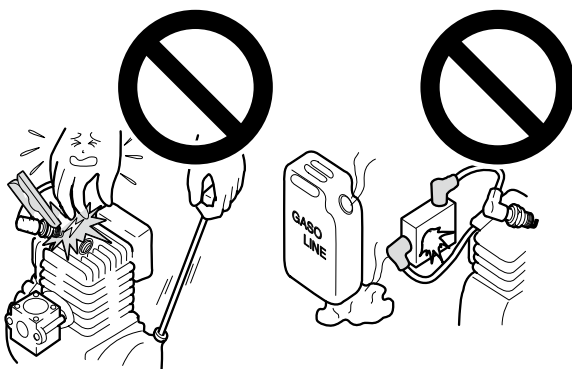

! DANGER

- *Do not test near spark plug hole without spark plug installed, otherwise there is a chance to ignite fuel mixture inside cylinder.
- *Do not touch metal parts of spark tester while performing the test to avoid receiving electrical shock.
- *Do not check spark in area where gasoline is spilled or flammable gases may exist.

3-3 Inspecting spark plug

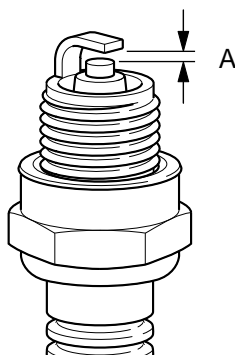

1. Remove spark plug to inspect for spark plug gap fouling, cracked or broken insulator, cracked outer electrode, or rounded center electrode. Replace spark plug as required.

Spark plug gap (A) standard
: 0.6 to 0.7 mm (0.024 to 0.028 in)

2. If engine does not start with correct spark plug, inspect if spark plug is wet or dry. If it is excessively wet or dry, inspect fuel system.

3-4 Inspecting ignition switch

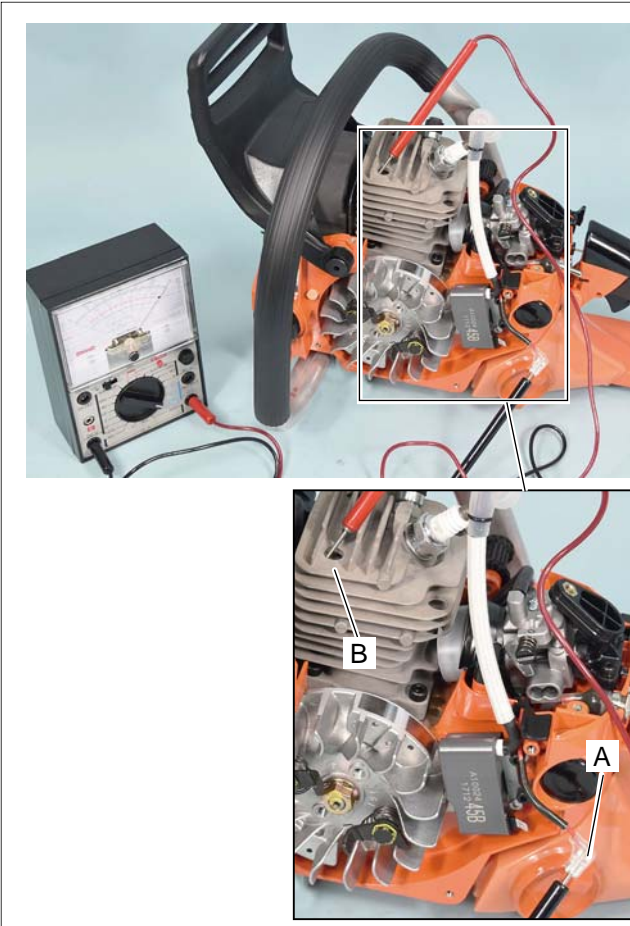

1. Remove cleaner lid, air filter and cylinder cover.
2. Remove switch lead (A) from ignition coil.
3. Connect one probe of Ohm-meter or multi-meter to switch lead. Connect the other probe to cylinder fin (B).
4. When ignition switch is in "I" position, tester should indicate infinite resistance.
5. When ignition switch is in "O (STOP)" position, tester should show that the circuit is in conducting state (closed circuit).
6. If ignition switch is defective, replace with a new one.

3-5 Replacing ignition switch

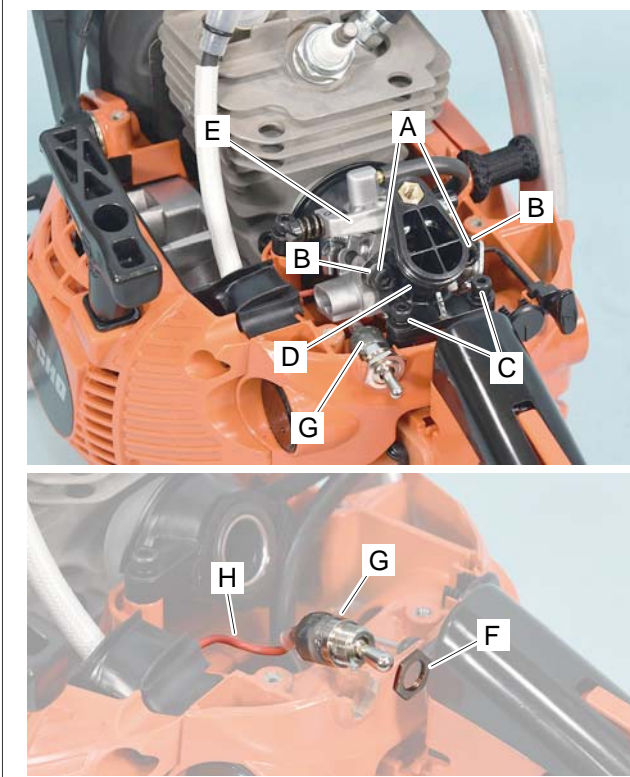

1. Remove cleaner lid, air filter and cylinder cover.
2. Remove bolts (A), washers (B) and bolts (C).
3. Remove carburetor elbow (D) and carburetor (E).
4. Loosen nut (F), and remove ignition switch (G) with switch lead (H) from the unit.
5. Assemble new ignition switch with switch lead on the unit. Fasten nut (F) on ignition switch.

3-6 Inspecting ignition coil resistance

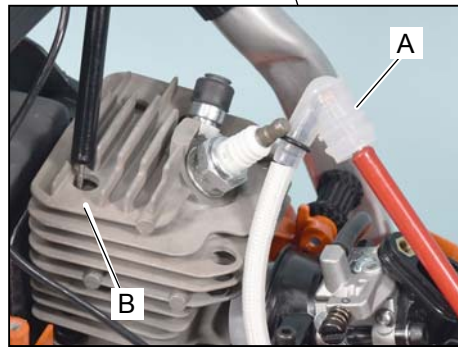

1. Remove cleaner lid, air filter and cylinder cover.
2. Connect one probe of Ohm-meter or multimeter to spark plug cap coil (A).
3. Connect the other probe to cylinder fin (B) to measure secondary coil resistance. Secondary coil resistance should be in the range of 2.5 to 2.9 k Ω .
4. If the meter reading indicates infinite resistance, remove spark plug cap and spark plug cap coil, and measure resistance between the conduction wire of high tension lead and ignition coil core.
5. If the reading at step 2 or 3 is not in the range of 2.5 to 2.9 k Ω , replace with a new ignition coil (Go to "3-8 Replacing ignition coil").

3-7 Replacing spark plug cap and coil

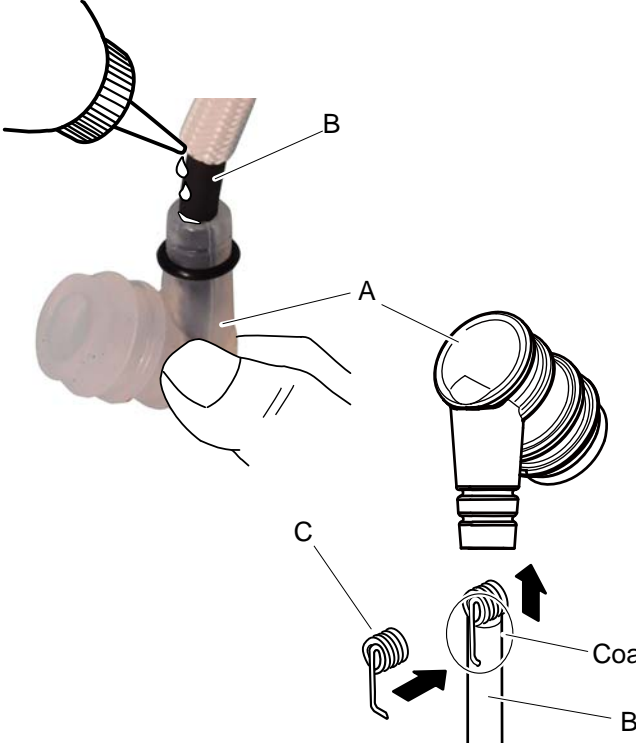

1. Disconnect spark plug cap (A) from spark plug. Remove cap cover from spark plug cap.
2. Apply some oil in spark plug cap (A) for easy removal from high tension lead (B).
3. Pull spark plug cap away from high tension lead.
4. Inspect spark plug cap coil (C) for corrosion and correct connection. Inspect spark plug cap for cracks. Replace as required.

NOTE: Make sure spark plug cap coil (C) contacts center core of high tension lead when reinstalling it.

5. Coat end of high tension lead (B) with small amount of oil, and insert it into spark plug cap (A) as shown, until the spark plug cap coil is properly seated in the cap.

3-8 Replacing ignition coil

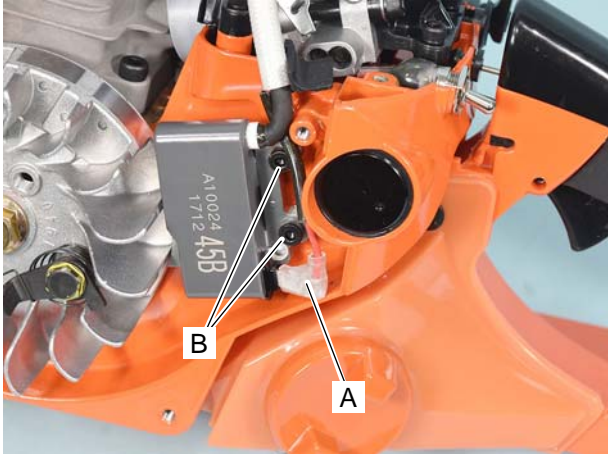

1. Remove cleaner lid. Disconnect spark plug cap from spark plug. Remove cylinder cover.
2. Remove starter assembly and fan cover referring to "2-1 Disassembling starter assembly".
3. Disconnect switch lead (A) from ignition coil. Loosen bolts (B) of ignition coil.
4. Remove ignition coil from cylinder.
5. Remove spark plug cap and spark plug cap coil from high tension lead (Refer to "3-7 Replacing spark plug cap and coil").
6. Install spark plug cap and spark plug cap coil, switch lead (A) to new ignition coil.
7. Loosely install new ignition coil with two bolts (B). Set air gap (Refer to "3-9 Setting pole shoe air gaps"). Tighten two bolts (B). Reinstall fan cover, starter assembly and cylinder cover.
8. Connect spark plug cap to spark plug. Reinstall cleaner lid.

3-9 Setting pole shoe air gaps

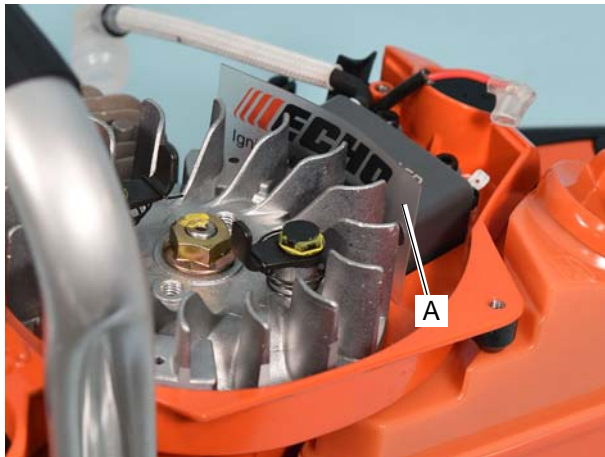

1. Insert Module air gap gauge: 91004 (A) or 0.3 - 0.4 mm (0.012 - 0.016 in) thick feeler gauge between flywheel and ignition coil shoes.
2. Rotate flywheel until magnetic poles of flywheel face ignition coil shoes.
3. Hold ignition coil against flywheel and tighten the bolts to specified torque (Refer to "Service information 1-3 Torque limits"). After tightening bolts, remove Module air gap gauge: 91004 (A) (or feeler gauge).

NOTE: When air gap is too narrow, contact with flywheel may result. When the air gap is too wide, spark is weak.

3-10 Inspecting flywheel and key

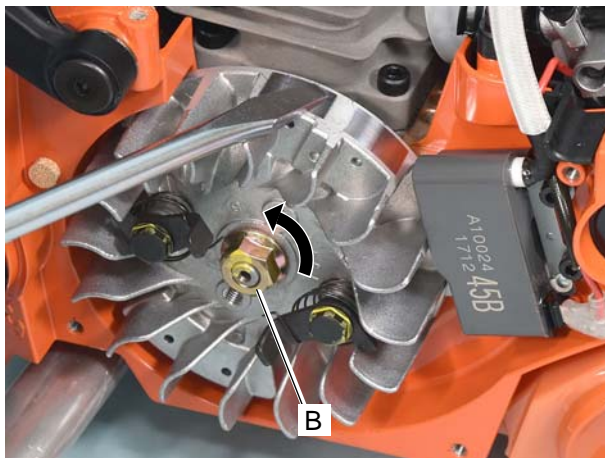

1. Inspect magnetic force of flywheel using flux meter, or bridging with flat head screwdriver as shown.
2. If magnetic force is weak, replace flywheel as follows.

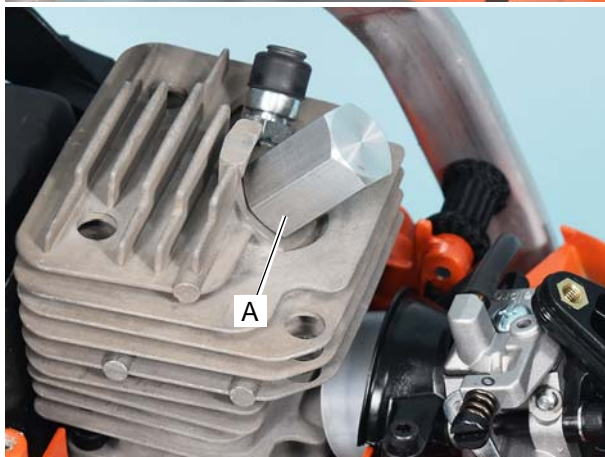

3. Install piston stopper X644-000020 (A) or clean rope into spark plug hole by hand, to stop crankshaft rotation.

NOTE: Do not use power tool to remove nut (B). Otherwise, piston damage may occur.

4. Remove nut (B) by rotating counterclockwise.

3-10 Inspecting flywheel and key (continued)

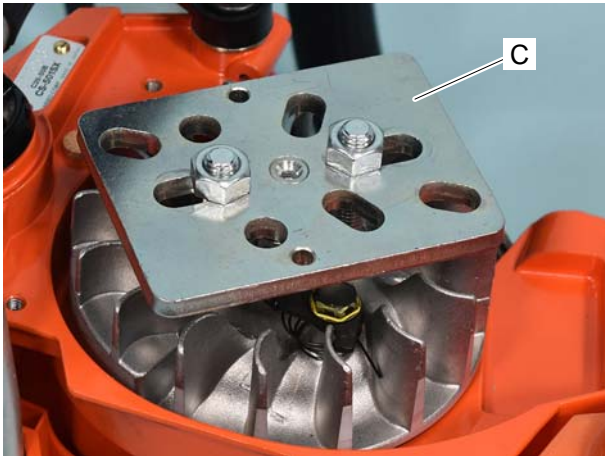

5. Remove starter pawls. Then set Puller Y089-000111 (C) on flywheel as shown.

6. Tighten two nuts on the puller alternately to remove flywheel.

7. Inspect woodruff key for damage or shearing. Replace as required.

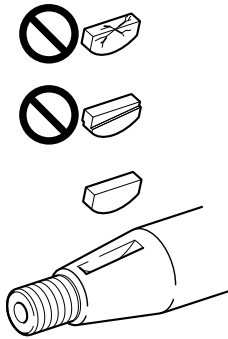

8. Wipe off oil from taper part of crankshaft before assembling flywheel.

9. Install woodruff key into key groove.

10. Reinstall starter pawls (Refer to "2-4 Replacing starter pawl").

11. Align flywheel key groove with woodruff key on crankshaft. Install flywheel and fasten flywheel nut clockwise.

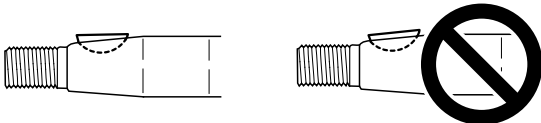

4 FUEL SYSTEM

- (A) Fuel cap
- (B) O-ring
- (C) Fuel tank vent
- (D) Fuel tank
- (E) Fuel strainer
- (F) Fuel line
- (G) Pulse line
- (H) Carburetor
- (J) Carburetor elbow
- (K) Gasket
- (L) Air filter
- (M) Cleaner lid

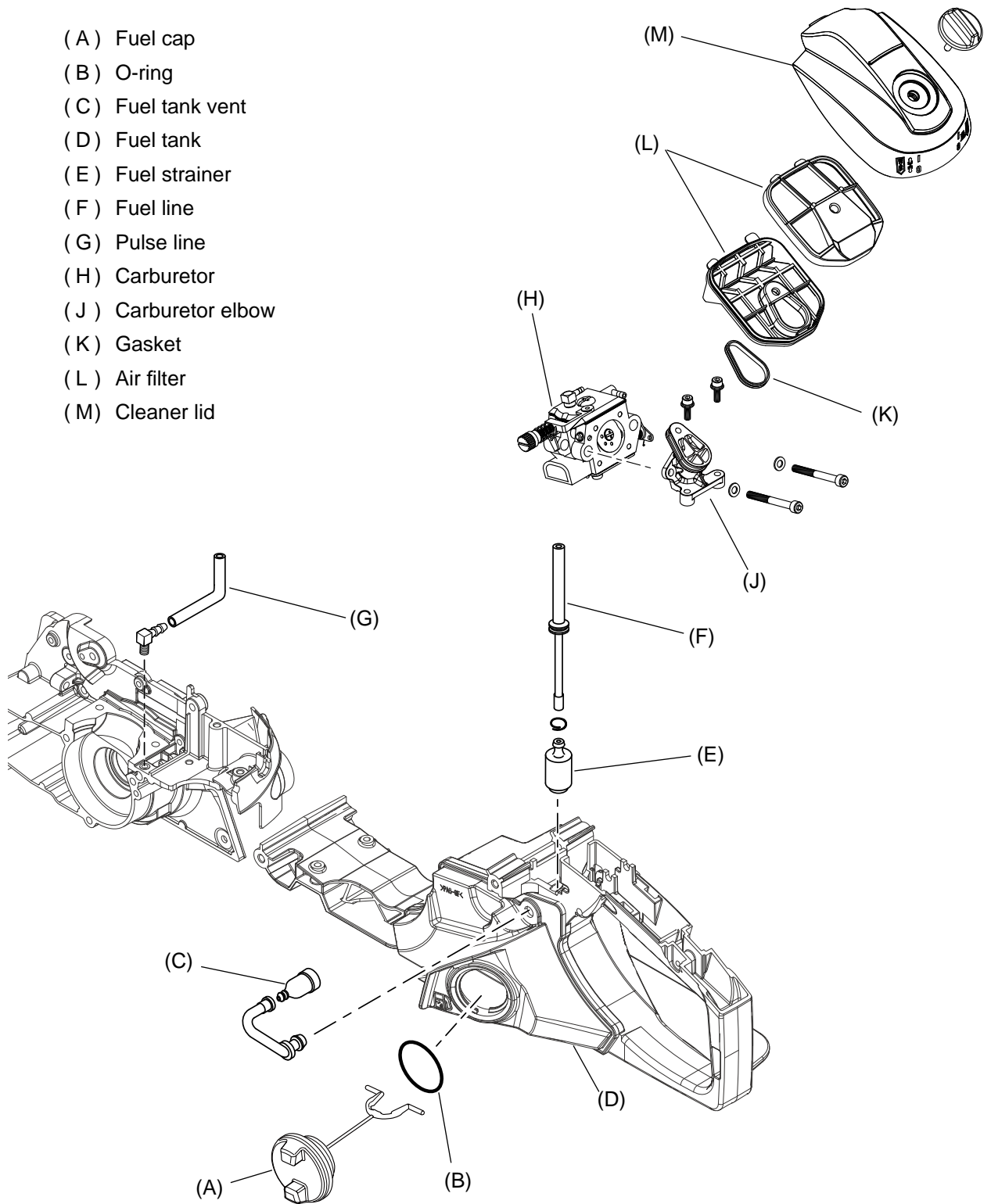

4-1 Inspecting air filter

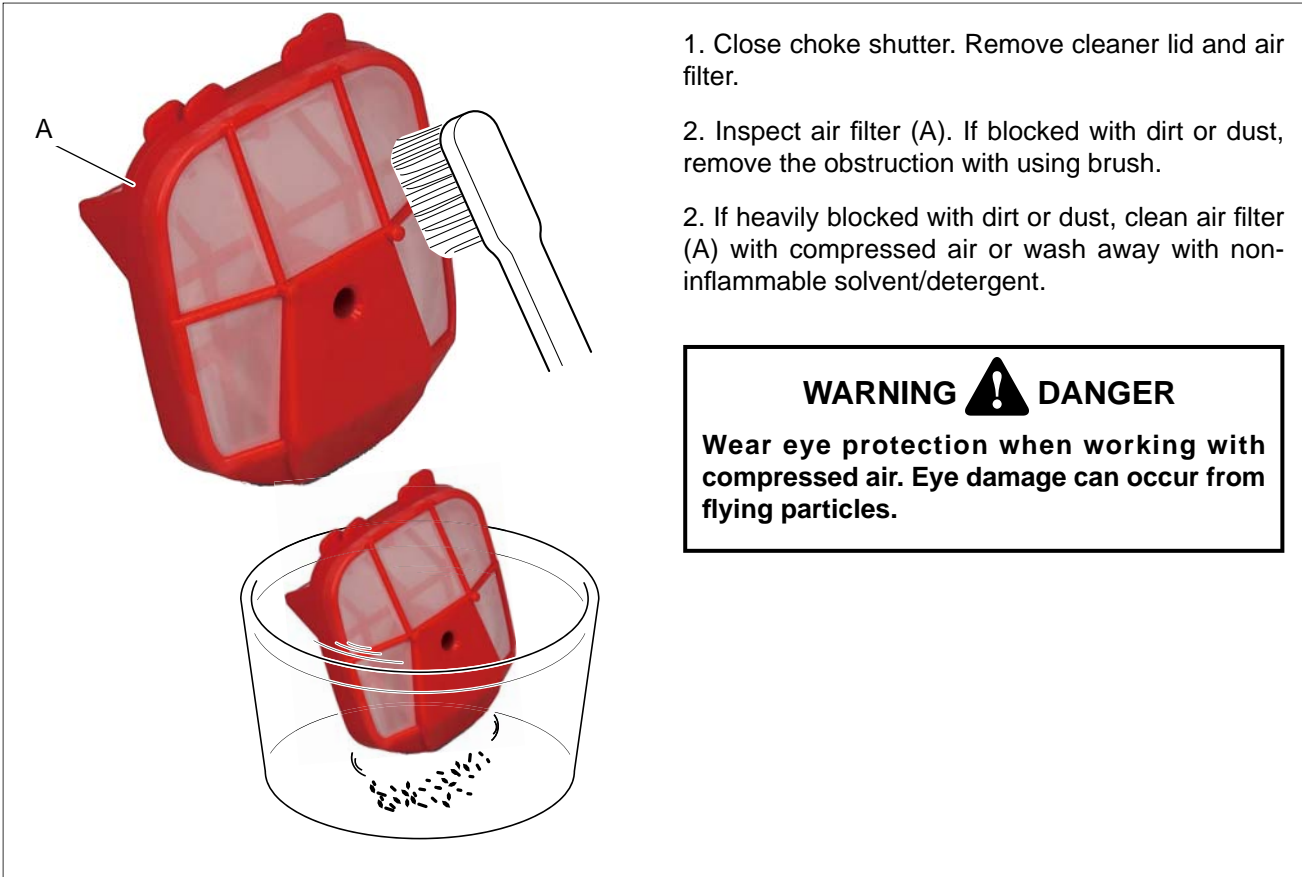

4-2 Inspecting fuel cap and fuel strainer

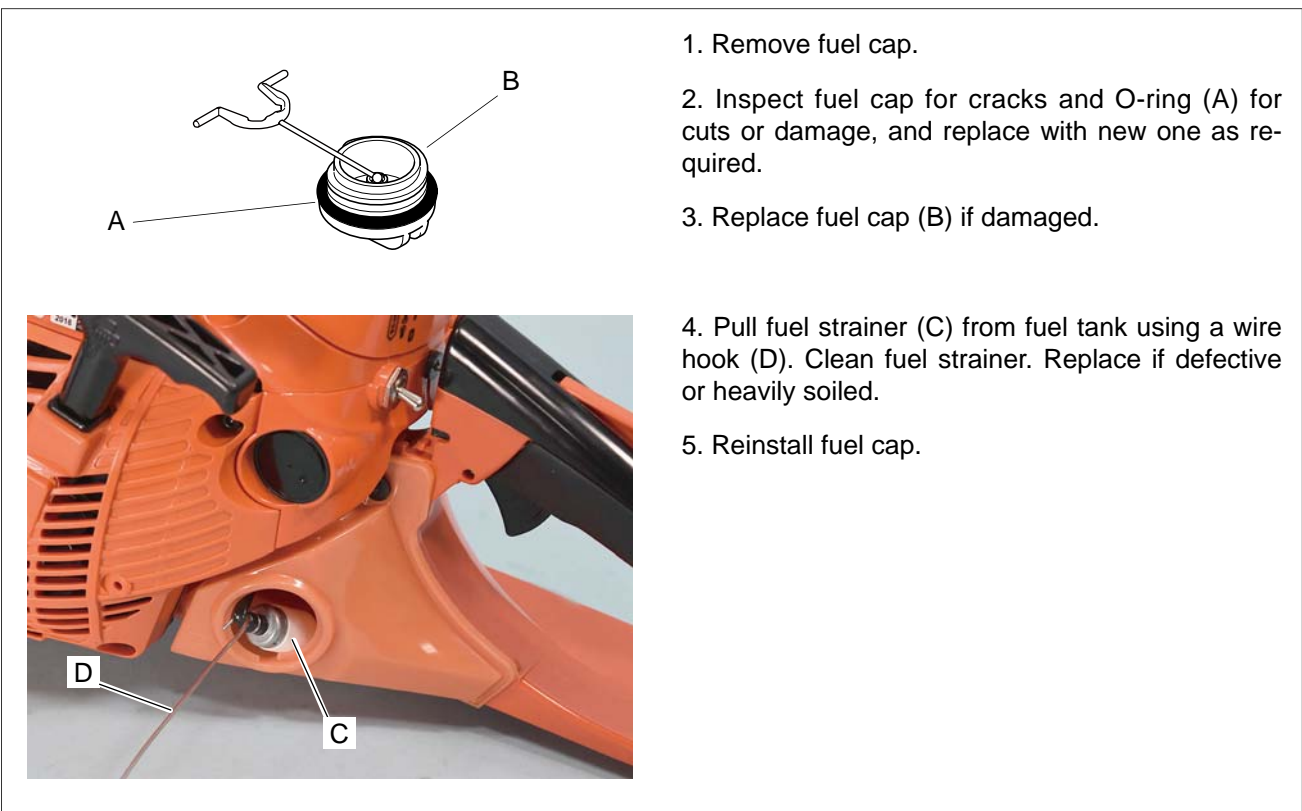

4-3 Inspecting fuel tank and line

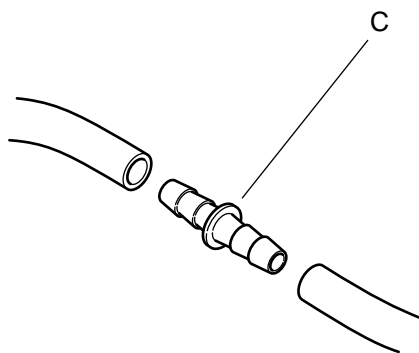
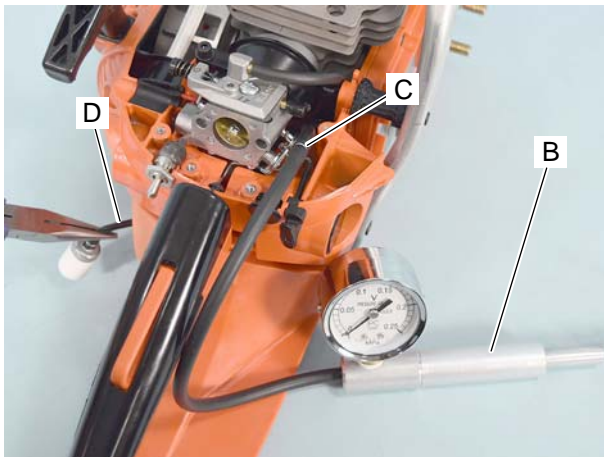

1. Clean fuel tank inside as required.
2. Remove cleaner lid, air filter and cylinder cover.
3. Disconnect fuel line (A) from carburetor.

4. Connect Pressure tester 897803-30133 (B) to fuel line.

NOTE: To connect pressure tester to fuel line, it is recommended to use pipe joint V186-000020 (C).

5. Remove fuel cap and pull out fuel strainer from fuel tank.

6. Pinch fuel line (D) with longnose pliers as shown.

NOTE: Wrap the ends of longnose pliers with tape (or cover with soft pipes) to protect fuel line from damage.

7. Apply pressure approx. 49 kPa (0.5 kgf/cm²) (7 psi).

8. If pressure drops, replace fuel line.

9. Put fuel strainer in fuel tank and fasten fuel cap securely.

10. Apply pressure approx. 9.8kPa (0.1 kgf/cm²) (1.4 psi).

11. Pressure should not drop. If pressure drops, leakage may occur from fuel cap, fuel cap O-ring, mating surface of fuel tank on rear handle, grommet, or tank vent. Inspect and replace defective part(s) with new one.

12. Remove pressure tester and connect fuel line to carburetor.

4-4 Inspecting and replacing tank vent

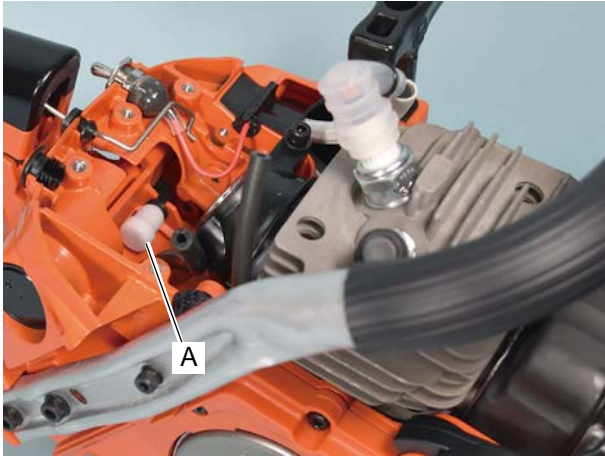

NOTE: Tank vent prevents a vacuum from forming in fuel tank when fuel in fuel tank is being consumed. When pressure in fuel tank becomes too high, tank vent releases the pressure.

1. Remove cleaner lid, air filter and cylinder cover. Remove tank vent (A) from fuel tank (Refer to “9-1 Replacing cushions”) and connect Pressure / vacuum tester 91149 (B).

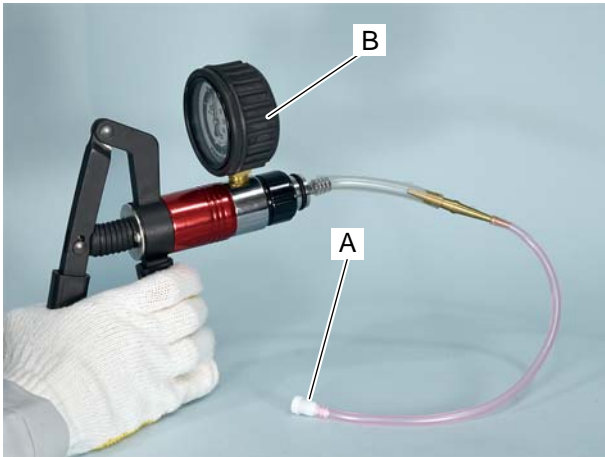

2. Apply pressure approx. 49 kPa (0.5 kgf/cm²) (7 psi). Make sure pressure is stable in range of 9.8 - 39.2 kPa (0.1 - 0.4 kgf/cm²) (1.4 - 5.7 psi).

3. If it is not in the range, gently clean tank vent with compressed air or replace with new one.

NOTE: Do not disassemble valve in tank vent assembly. Damage to valve will occur.

4. Apply negative pressure 19.6 kPa (0.2 kgf/cm²) (3 psi).

5. Tank vent should pass air freely without holding any pressure. If it does not, replace tank vent with new one.

4-4 Inspecting and replacing tank vent (continued)

NOTE: Inspection using 897803-30133

If Pressure / vacuum tester 91149 is not available, tank vent can be inspected with Pressure tester 897803-30133 as follows.

1. Connect tank vent (A) to Pressure tester 897803-30133 (B).
2. Apply pressure approx. 49 kPa (0.5 kgf/cm²) (7 psi), make sure pressure is stable in range of 9.8 - 39.2 kPa (0.1 - 0.4 kgf/cm²) (1.4 - 5.7 psi).
3. If it is not in the range, gently clean tank vent with compressed air or replace with new one.

NOTE: Do not disassemble valve in tank vent assembly as shown. Damage to valve will occur.

4. Remove cap (C) of tank vent, and clean sponge (D).
5. Cut pipe 363011-00210 (E: 7x11x170mm) and 382011-01110 (F: 9x13x350) in approx. 30mm (1 1/4 in) length, and connect them to pressure tester as shown. Connect tank vent (A) without cap to pipe as shown.
6. Plug hole (a) with finger and apply pressure 19.6 kPa (0.2 kgf/cm²) (3 psi). The pressure should hold steady.
7. Remove finger from hole (a). Tank vent should pass air freely without holding any pressure. If it does not, replace tank vent with new one.

4-5-1 Replacing fuel line

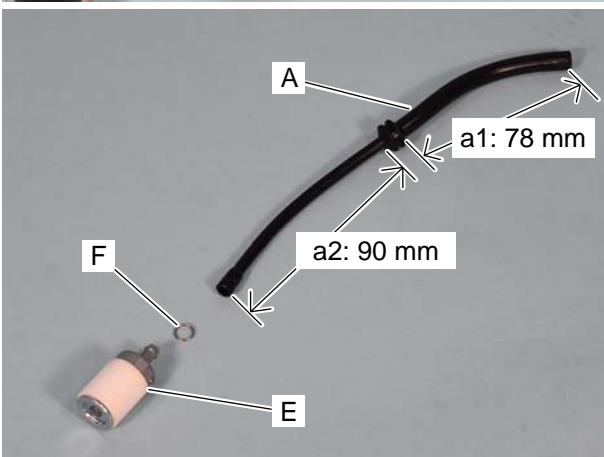
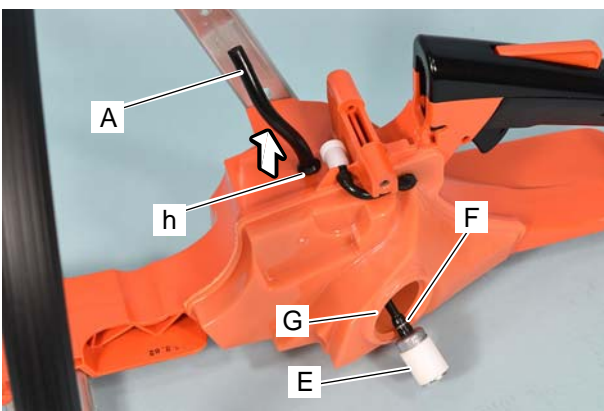
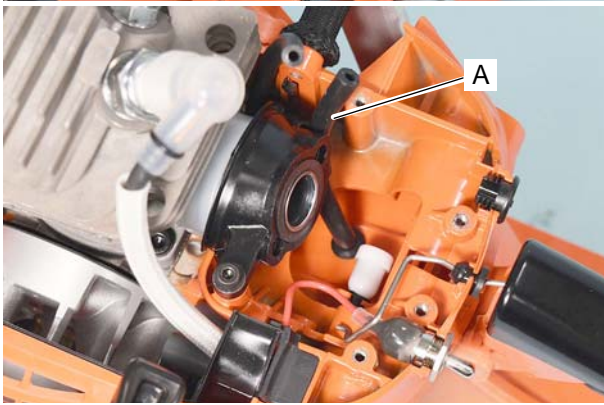
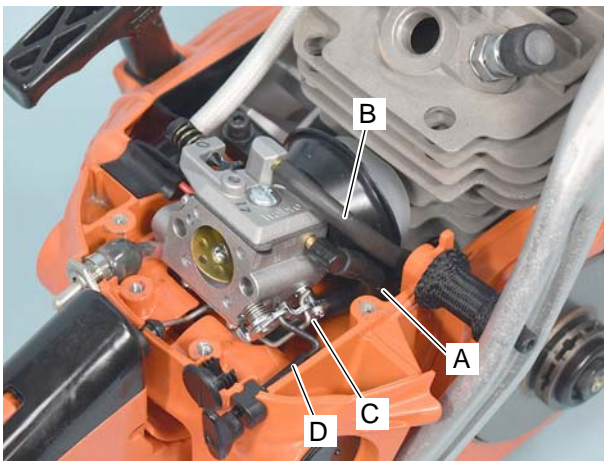

1. Remove cleaner lid, air filter and cylinder cover.
2. Disconnect fuel line (A) and pulse line (B) from carburetor.
3. Remove carburetor by disconnecting throttle rod (C) and choke knob (D).
4. Remove crankcase assembly (Refer to "9-1 Replacing cushions").
5. Remove fuel cap, and remove fuel strainer (E) and clip (F) from fuel line (A).
6. Pull out fuel line (A) in direction of arrows. Replace them if defective.
7. Set clip (F) on new fuel line (A) and connect fuel strainer (E).
8. Insert shorter side (a1) of new fuel line (A) through fuel tank (G). Pull out fuel line (A) through hole (h) in direction of arrows.
9. Reinstall crankcase assembly (Refer to "9-1 Replacing cushions"), carburetor (Refer to "4-14 Installing carburetor"), cleaner case, air filter and cleaner lid.

4-5-2 Replacing fuel vent pipe

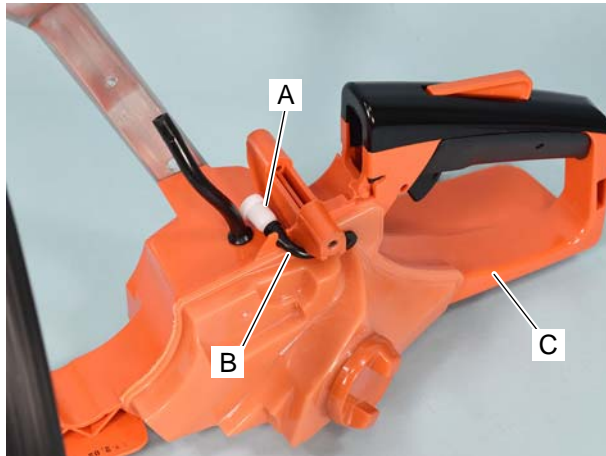

1. Remove fuel tank vent (A) with pipe (B) from rear handle assembly (C).

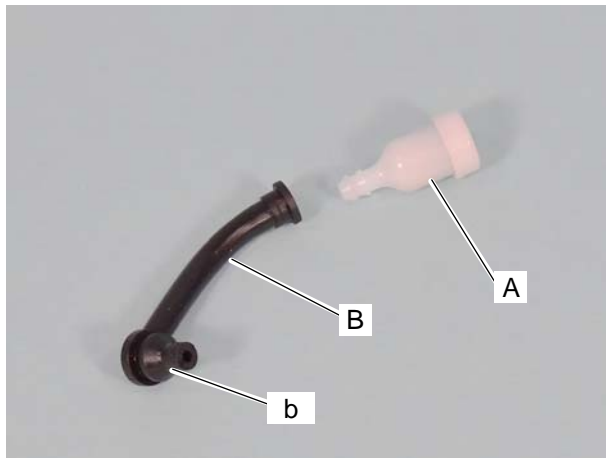

2. Disconnect pipe (B) from fuel tank vent (A). Replace them if defective (Refer to "4-4 Inspecting and replacing tank vent").

3. Connect pipe (B) to fuel tank vent (A).

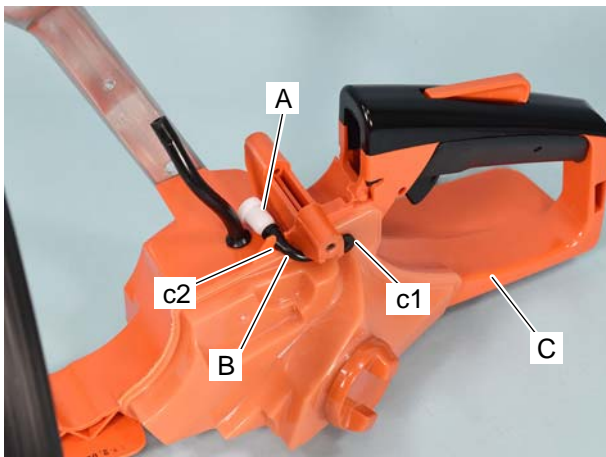

4. Insert pipe (b) to hole (c1) on rear handle assembly (C). Pass pipe (B) through notch (c2) on rear handle assembly (C).

5. Reinstall crankcase assembly (Refer to "9-1 Replacing cushions"), carburetor (Refer to "4-14 Installing carburetor"), cleaner case, air filter and cleaner lid.

4-6 Adjusting carburetor

4-6-1 General adjusting rules

A. Before adjustment, check the following items.

1. The correct spark plug must be clean and properly gapped.
2. The air filter element must be clean and properly installed.
3. The muffler exhaust port must be clear of carbon.
4. The fuel lines, tank vent and fuel filter are in good condition and clear of debris.
5. The fuel is fresh (> 89 octane : RON) and properly mixed at 50 : 1 with "ISO L-EGD" or "JASO FC/FD" 2-stroke oil.
6. 40, 45 or 50 cm bar and chain must be installed, and properly tensioned.
7. For CS-501SXH, turn off the heater switch.

B. Preliminary adjustment. Adjustment by Throttle adjust screw of carburetor.

Start and run engine for 100 seconds alternating engine speed between WOT and idle every 5 seconds. Adjust throttle adjust screw to 2,700 +/- 200 r/min. Make sure WOT engine speed in range 13,000 - 13,800 r/min. If engine does not run correctly after this adjustment, proceed to the next step 2-2.

4-6-2 Initial setting Throttle adjust screw, L mixture needle and H mixture needle

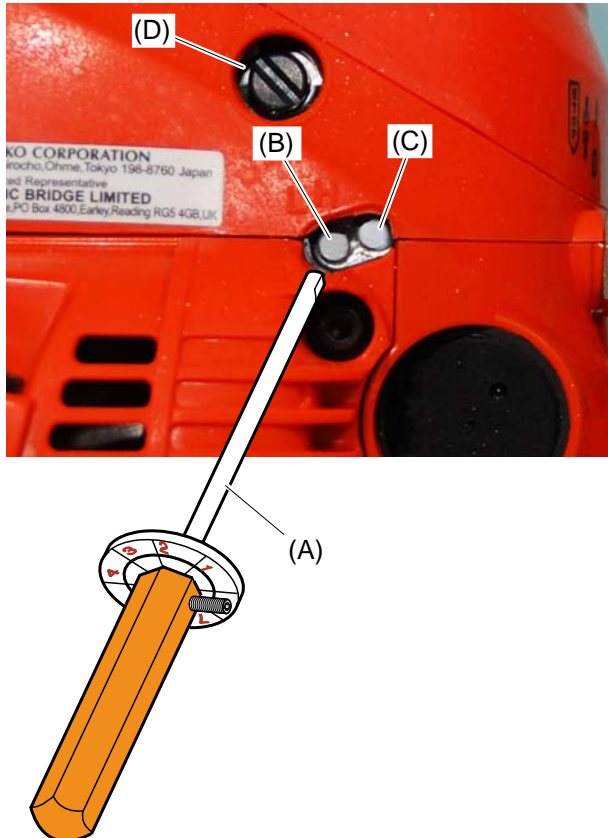

Tools Required: Small flat head screwdriver with 2.5 mm blade, P/N 897802-33330 tachometer PET-1000R, P/N Y089-000094 Carburetor adjustment tool (A).

1. Turn L and H mixture needles clockwise until lightly seated, and then turn out both mixture needles following turns:

L mixture needle (B) : 1 3/4

H mixture needle (C) : 3 5/8

NOTE: If needles are overtightened during seating, damage to carburetor may occur.

2. Remove air cleaner lid and air filter to expose the Throttle adjust screw and throttle plate. Turn Throttle adjust screw (D) counterclockwise until Throttle adjust screw tip just touches throttle plate. Then turn Throttle adjust screw (D) 2 1/8 turns clockwise. Reinstall air filter, and cleaner lid.

NOTE : The initial carburetor settings for Throttle adjust screw, L and H mixture needles are intended to start and run the engine before final carburetor adjustments are made through this procedure. The actual number of turns needed for engine operation may vary.

4-6-3 Adjusting carburetor

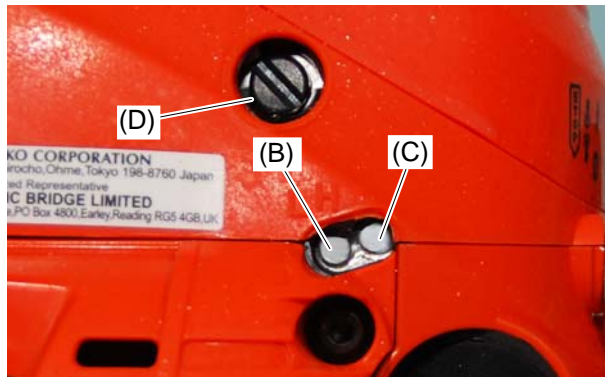

1. Start and warm engine for 100 seconds alternating engine speed between WOT and idle every 5 seconds. Turn H mixture needle (C) counterclockwise until engine speed drops to approx. 12,500 r/min at WOT.

NOTE : Do not run engine at high speed without load longer than 10 seconds, or engine damage may occur.

2. Adjust L mixture needle (B) using Carburetor adjustment tool (A) to reach maximum engine speed just before lean drop off.

If chain starts to rotate during adjustment, decrease engine speed by turning throttle adjust screw (D) counterclockwise until chain stops and then readjust L mixture needle (B).

3. Set idle speed to 3,500 r/min by turning Throttle adjust screw (D). Engine speed should be stable at 3,500 +/- 50 r/min after Throttle adjust screw adjustment.

4. Turn L mixture needle (B) counterclockwise reducing engine idle speed 800 r/min to set idle speed at 2,700 r/min. The engine idle speed ranges is 2,600 - 2,800 r/min.

NOTE : Engine speed must be allowed to stabilize a minimum of 20 seconds after each adjustment of L mixture needle to assure accurate tachometer readings.

5. Before adjustment, WOT engine speed should be 12,500 r/min or less. If engine speed is higher, turn H mixture needle (C) counterclockwise until 12,500 r/min is achieved. To make the final WOT engine speed adjustment, turn H mixture needle (C) clockwise in 1/8 turn increments with the engine at idle, then squeeze throttle trigger and check WOT engine speed. The final WOT engine speed should fall within 13,000 - 13,800 r/min.

6. Start engine, and verify engine idle speed ranges from 2,300 to 3,100 r/min, and WOT engine speed ranges from 13,000 to 13,800 r/min. Make sure the chain does not rotate when engine is idling. When final adjustment is completed, the engine should idle, accelerate smoothly, and attain WOT per above specifications.

NOTE : WOT and idle engine speed in field operation may vary from final adjustment specifications due to changing ambient conditions and fuel. Engine speed variances should be within the safe ranges for WOT and idle engine speed as listed in Section 1-2 Technical data, otherwise the carburetor should be readjusted.

4-7 Air shutter

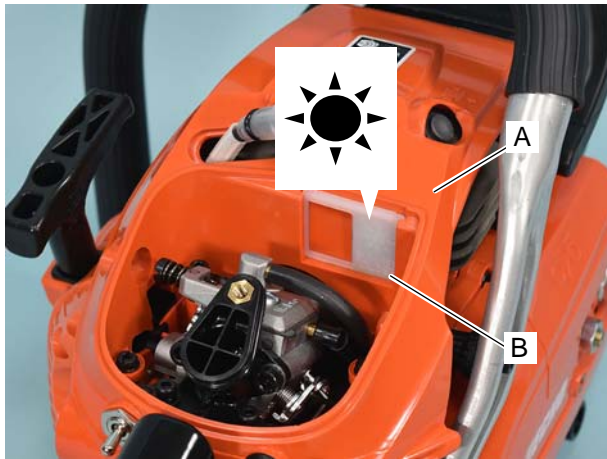

When it is cold weather (outside air temperature is 5 °C/41°F or lower) and acceleration is poor, release air shutter.

1. Air shutter is located in cylinder cover (A).
2. Picture shows normal position (sun mark) of air shutter (B).

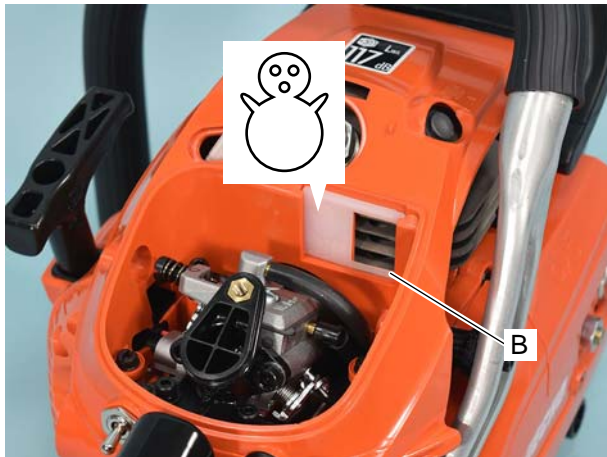

3. Reverse air shutter (B) to open position (snowman mark) to open air duct and introduce warm air from cylinder side to carburetor side.

NOTE: In order to avoid carburetor vapor lock, return air shutter to normal position (sun mark) when temperature is above freezing.

4-8 Testing carburetor

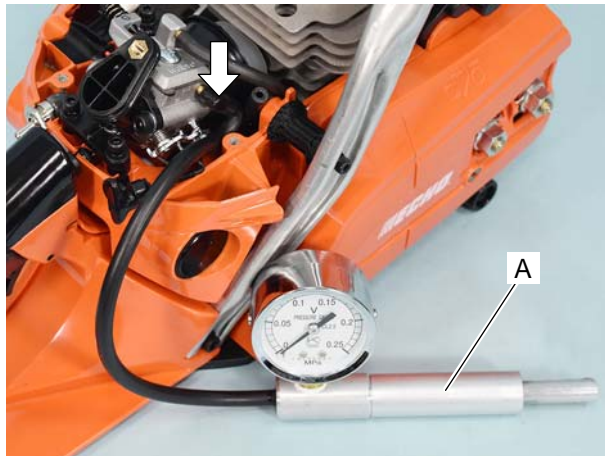

NOTE: To perform this test, carburetor interior should be wet with fuel. If dry, a little leakage may occur from diaphragms and/or inlet needle seat.

1. Remove cleaner lid, air filter and cleaner case. Disconnect fuel line from carburetor. Connect Pressure tester 897803-30133 (A) to carburetor fuel inlet.

2. Apply pressure approx. 98 kPa (1 kgf/cm²) (14 psi).

3. If pressure remains steady, follow step 4 and 5. If pressure drops, proceed to step 6.

4. Pull starter grip. Pressure tester reading should drop and remain above 49 kPa (0.5 kgf/cm²) (7 psi).

5. If reading does not drop, inspect inlet needle valve for sticking or metering lever height is too low.

6. If pressure drops at step 2, or if pressure drops below standard figure at step 4, remove carburetor from the unit, disconnecting pulse line, throttle rod and choke knob.

7. Submerge carburetor in suitable clean solvent to locate the leak by applying pressure approx. 98 kPa (1 kgf/cm²) (14 psi).

8. If air bubbles come out between pump cover and carburetor body (B), inspect pump diaphragm, pump gasket, and diaphragm seat of carburetor body (Refer to "4-12 Inspecting diaphragm").

9. If air bubbles come out from throttle bore (C), inspect inlet valve, metering lever spring, and metering lever height (Refer to "4-11 Inspecting inlet needle valve").

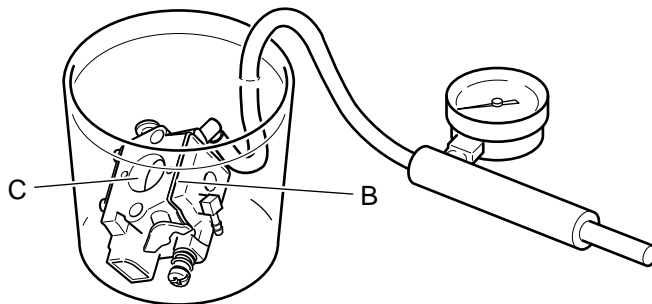

4-9 Inspecting crankcase pulse passage

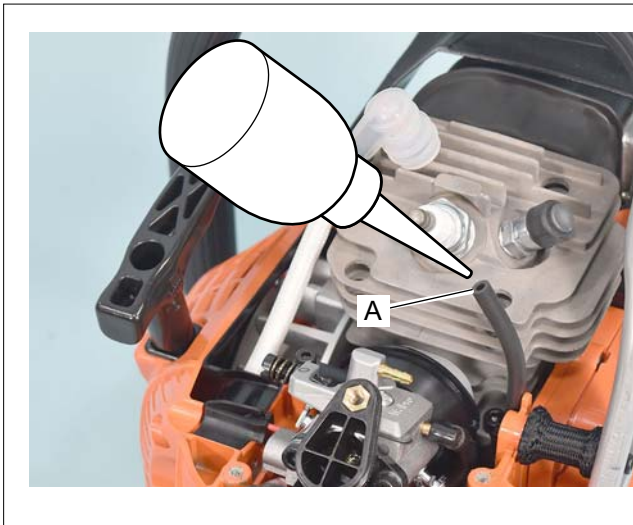

1. Drop a little oil in the end of pulse line (A) as shown.
2. Remove spark plug and pull starter grip several times. Oil should spit back from the hole.
3. If not, inspect whether pulse passage is clogged. Repair or replace as required.

4-10 Inspecting metering lever height

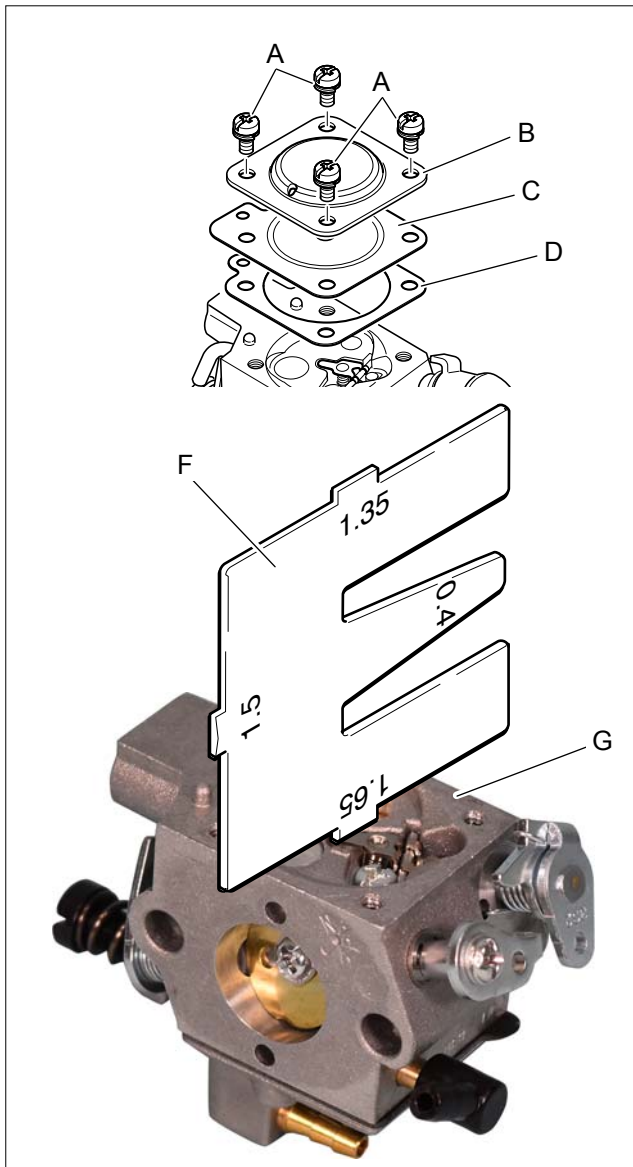

1. Remove carburetor.
2. Remove four screws (A), metering diaphragm cover (B), metering diaphragm (C) and gasket (D).

3. Inspect metering lever (E) height by Metering lever gauge 897563-19830 (F).

Metering lever height: 1.65 mm (0.065 in) lower than diaphragm seat (G).

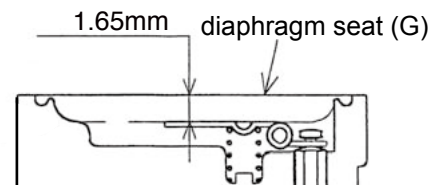

4. If necessary, gently bend metering lever (E) up or down to set metering lever to proper position.

NOTE: When metering lever is:

Too high → Fuel flooding occurs

Too low → Fuel starvation / overheating occurs

4-11 Inspecting inlet needle valve

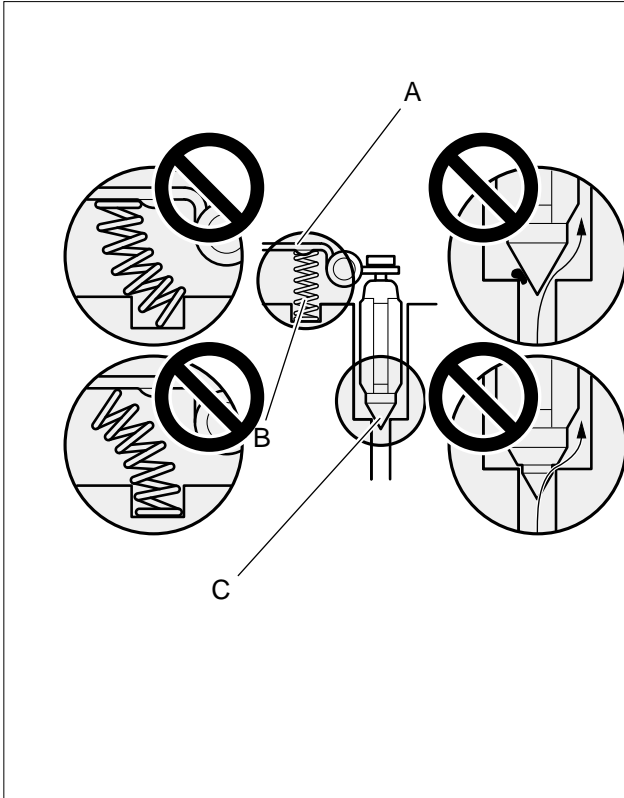

1. Remove metering lever (A) and pivot pin. Remove spring (B) and inlet needle valve (C).

2. Inspect inlet needle valve if worn or sticky. Clean or replace as required.

NOTE: Causes of fuel flooding from carburetor to cylinder are as follows:

- Improper assembling of metering lever and spring.
- Dirt between inlet needle valve and valve seat.
- Worn inlet needle valve tip.

3. Clean inlet needle valve seat using suitable clean solvent (do not use metal tools).

4. Reassemble inlet needle valve, spring, metering lever and pivot pin.

NOTE: Insure proper metering lever installation as follows.

- (1) Spring is seated in its hole at chamber floor.
- (2) Spring is under dimple of metering lever.
- (3) metering lever fork is holding inlet needle valve.

4-12 Inspecting diaphragm

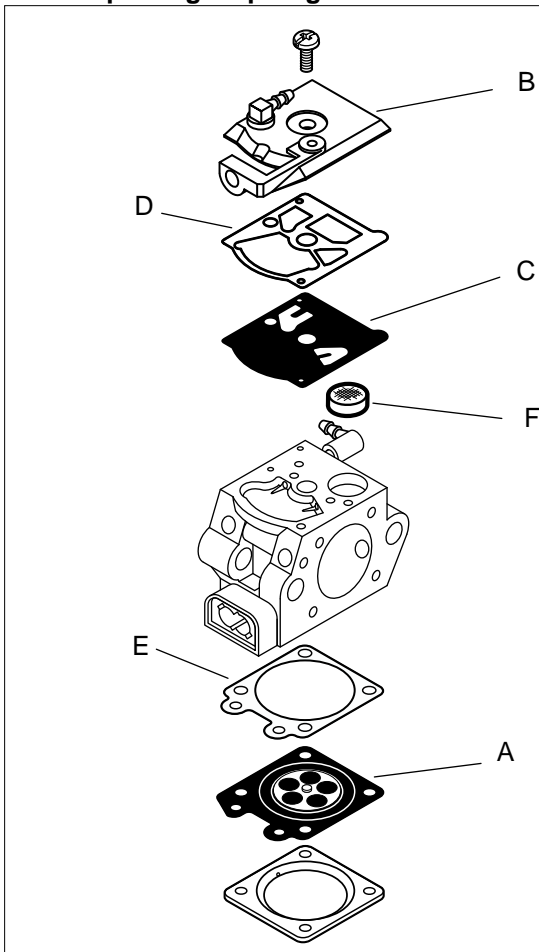

1. Inspect metering diaphragm (A) for hardening, distortion, or pin hole. Replace as required.

2. Remove pump cover (B), pump diaphragm (C) and pump gasket (D).

3. Inspect pump diaphragm (C) and replace if hardened or curled at valve tabs.

4. Inspect metering gasket (E) and pump gasket (D) and replace if defective.

5. Inspect inlet screen (F) if blocked, remove and clean it, or replace.

6. Clean fuel passages in carburetor body with compressed air.

NOTE: Before cleaning metering side with compressed air, turn "H" needle clockwise until lightly seated and remove inlet needle valve. Otherwise, main nozzle check valve and inlet needle valve spring may be damaged by the compressed air.

NOTE: When cleaning pump side with compressed air, take care not to blow inlet screen (F) away.

4-13 Replacing Welch plug

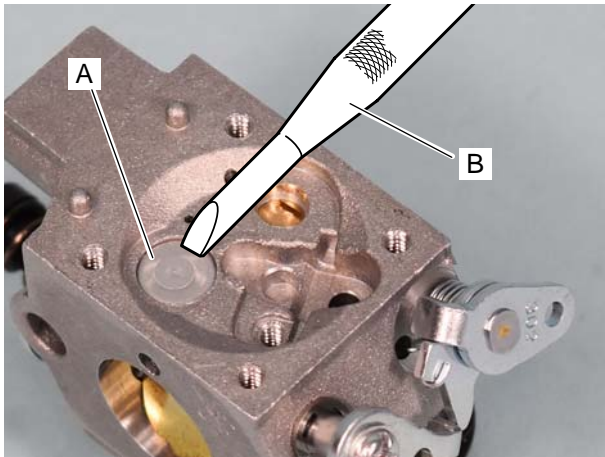

If engine does not run smoothly even after readjusting carburetor and inspecting carburetor parts, inspect low speed ports on carburetor as follows:

1. Remove metering lever and related parts to protect them from damage.
2. To remove Welch plug (A), punch the remover tool (B) through Welch plug at low angle and pry it out.

NOTE: Remover tool (B) and welch plug installer (C) are included in Welch plug tool kit (Part number: 500-500).

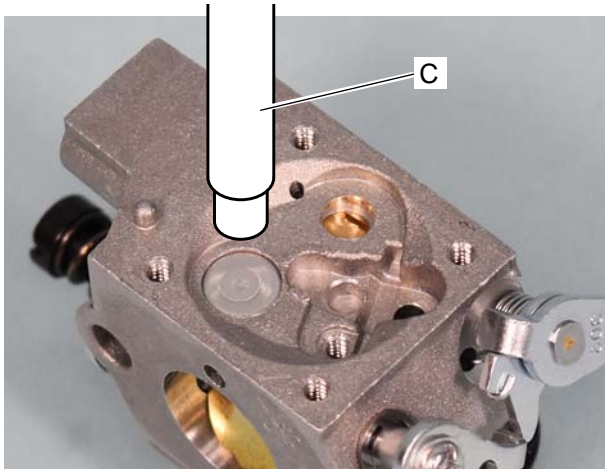

3. Clean low speed ports with compressed air.
4. Place a new Welch plug over the opening and gently tap it until flush using welch plug installer (C).
5. Install all removed parts to carburetor body.

4-14 Installing carburetor

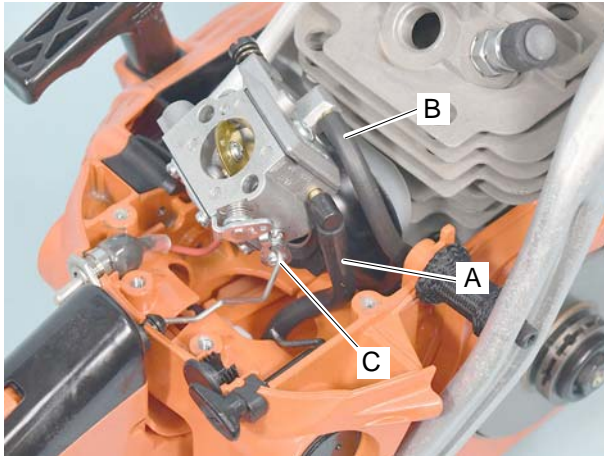

1. Connect fuel line (A) and pulse line (B) to carburetor as shown.

2. Connect throttle rod (C) to carburetor.

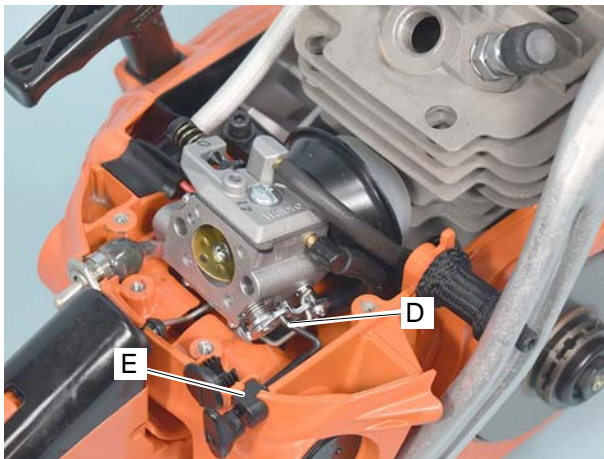

3. Connect choke rod (D) with choke grommet (E) to carburetor.

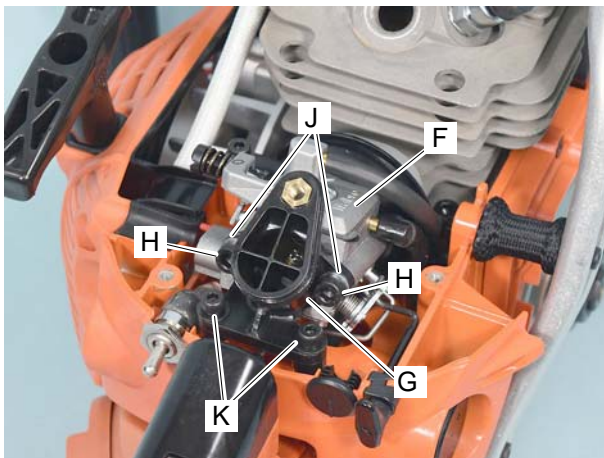

4. Secure carburetor (F) and carburetor elbow (G) with bolts (H), washers (J) and bolts (K).

5 CLUTCH SYSTEM

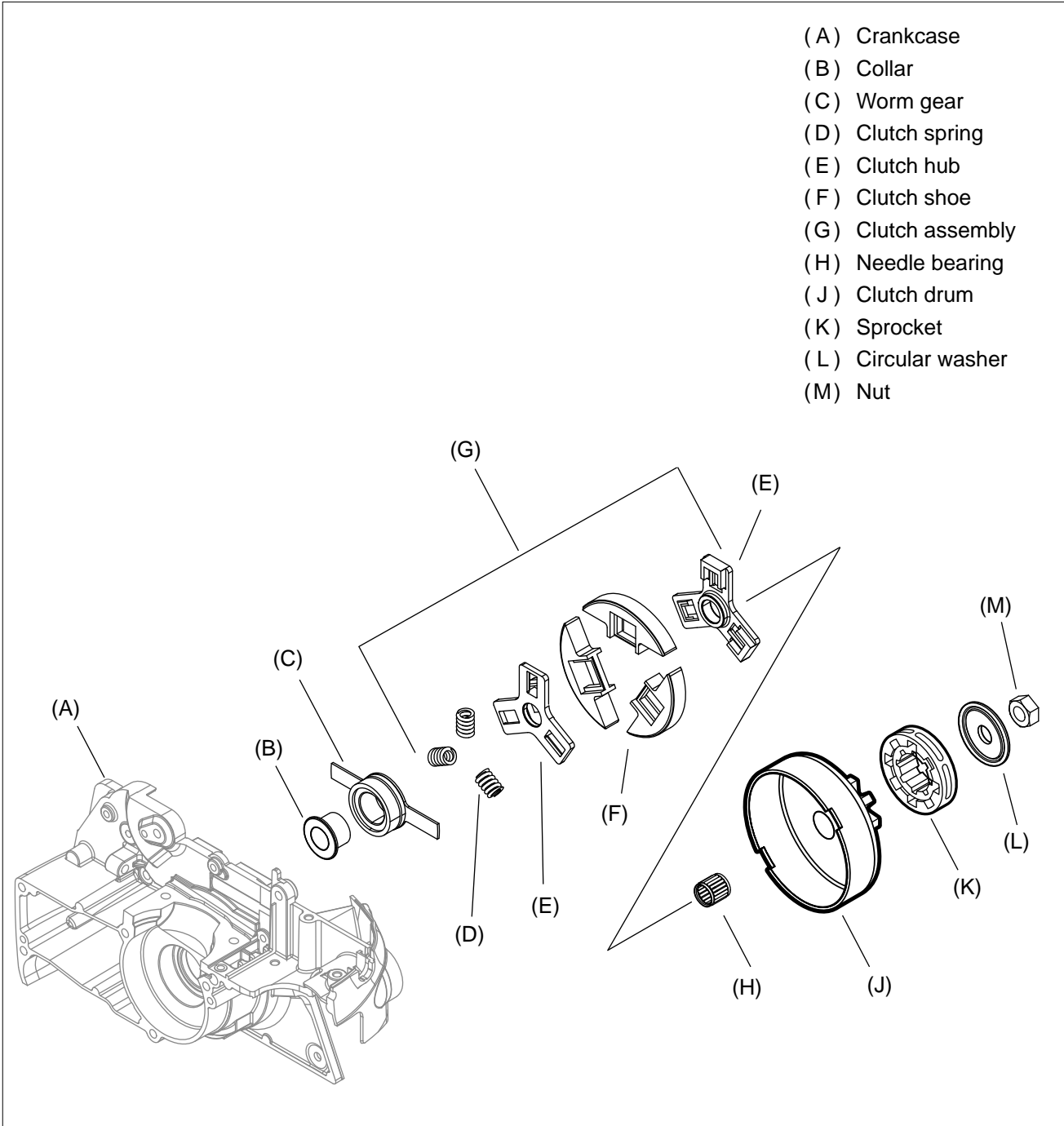

- (A) Crankcase
- (B) Collar
- (C) Worm gear
- (D) Clutch spring
- (E) Clutch hub
- (F) Clutch shoe
- (G) Clutch assembly
- (H) Needle bearing
- (J) Clutch drum
- (K) Sprocket
- (L) Circular washer
- (M) Nut

5-1 Inspecting clutch parts

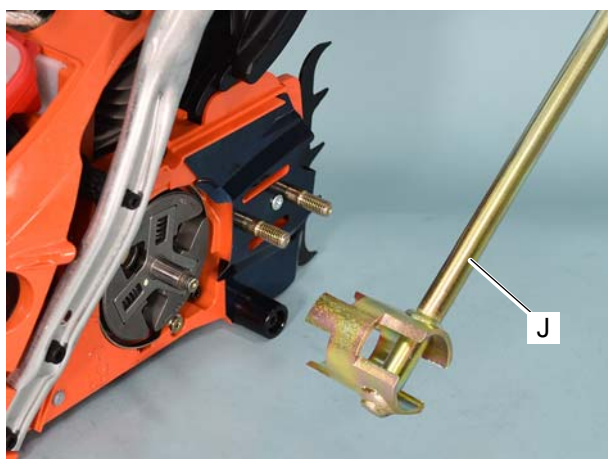
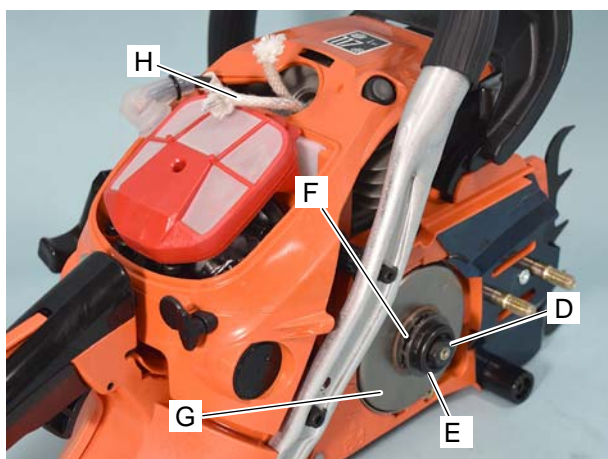

1. Remove sprocket guard (A), cleaner lid (B) and air filter.

NOTE: If starter assembly is installed, pull starter rope out about 20 cm (8 in), and make a temporary knot (C) to prevent starter damage when installing clutch assembly.

2. Disconnect spark plug cap and remove spark plug.

3. Install clean rope (H) or piston stopper X644-000020 in spark plug hole to stop crankshaft rotation.

4. Rotate clutch assembly clockwise by hand until it cannot be rotated further.

5. Remove nut (D), circular washer (E) and sprocket (F).

6. Remove clutch drum (G) with needle bearing inside.

7. Loosen clutch assembly (Left-hand thread) rotating clockwise with Clutch tool X640-000370 (J) and remove it.

8. Remove collar and worm gear.

9. Inspect clutch shoes for wear and spring for weakness or damage. Replace clutch parts as required.

10. Inspect clutch drum, sprocket, nut and circular washer. Replace if deformed or worn out.

11. Inspect needle bearing, collar and worm gear for damage, discoloration or deformation. Replace as required.

5-2 Replacing clutch parts

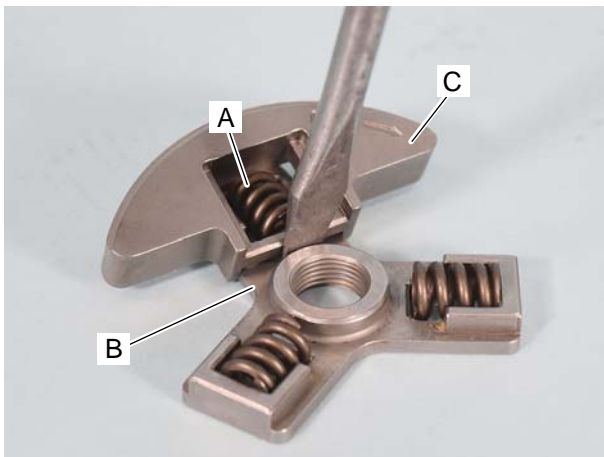

1. Install three clutch spring (A) to outside clutch hub (B).

2. Set three clutch shoes (C) to each arms of clutch hub (B) by flat head screwdriver.

3. Set inside clutch hub (D) to clutch assembly by small flat head screwdriver.

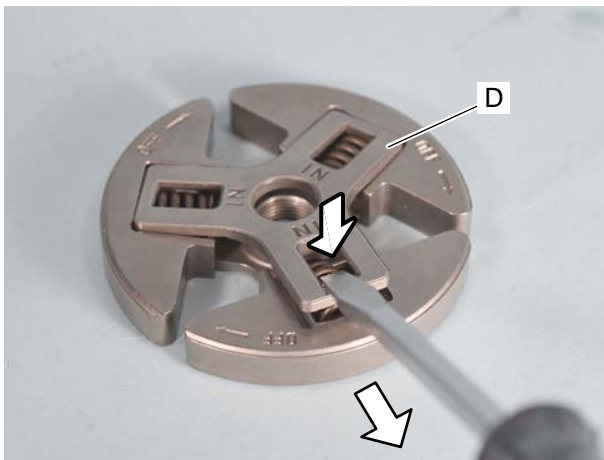

5-3 Installing clutch assembly

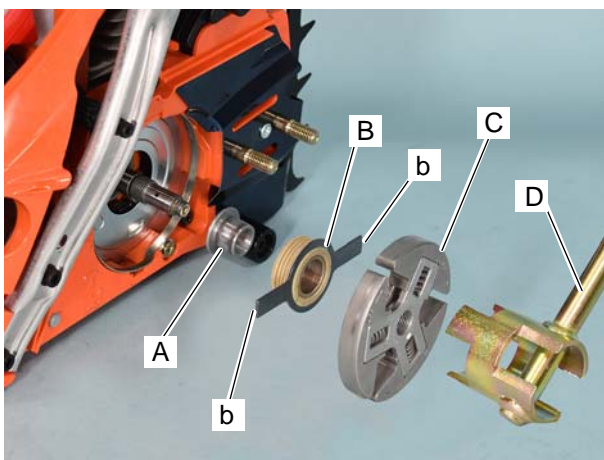

1. Install collar (A) and worm gear (B) in the order shown, making sure collar and worm gear are engaging.

2. Install clutch assembly (C; Left-hand thread) to crankshaft turning anticlockwise by hand until it can not be turned further.

NOTE: If starter assembly is installed, untie temporary knot holding starter grip (tied in the first NOTE of "5-1 Inspecting clutch parts"). While holding starter grip, turn clutch assembly anticlockwise until it cannot rotate further.

3. Tighten clutch assembly (C) with Clutch tool X640-000370 (D).

5-3 Installing clutch assembly (Continued)

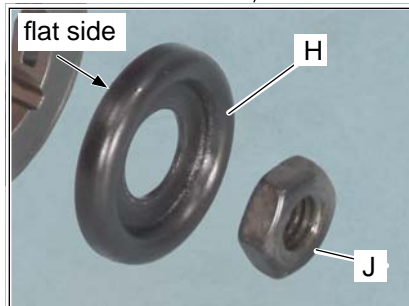
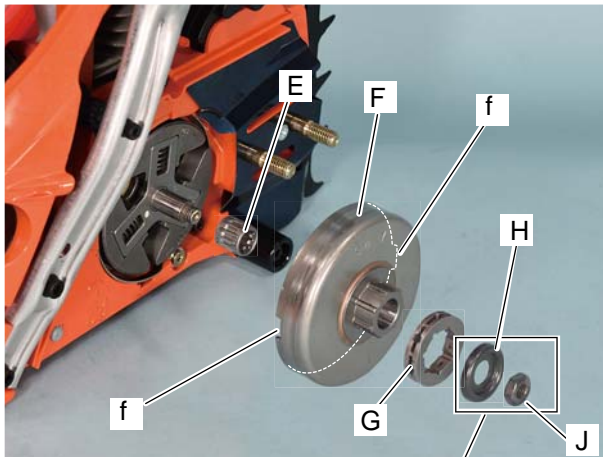

4. Apply lithium-based grease to needle bearing (E). Install clutch drum (F) and needle bearing (E) on crankshaft, placing the hands (b) of worm gear (B) in cutouts (f) of clutch drum.

5. Install sprocket (G). Install circular washer (H), facing flat side to sprocket (G).

6. Install nut (J).

7. Remove rope and reinstall all removed parts.

6 CHAIN BRAKE SYSTEM

- | | |
|------------------------|----------------------------|
| (A) Brake lever | (J) Brake cover |
| (B) Collar | (K) Sprocket guard plate |
| (C) Torsion spring | (L) Sprocket guard plate |
| (D) Brake seal plate | (M) Chain tensioner |
| (E) Brake band | (N) Collar |
| (F) Spring pin | (P) Bevel gear |
| (G) Coil spring | (R) Sprocket guard |
| (H) Brake connector | (S) Crankcase |

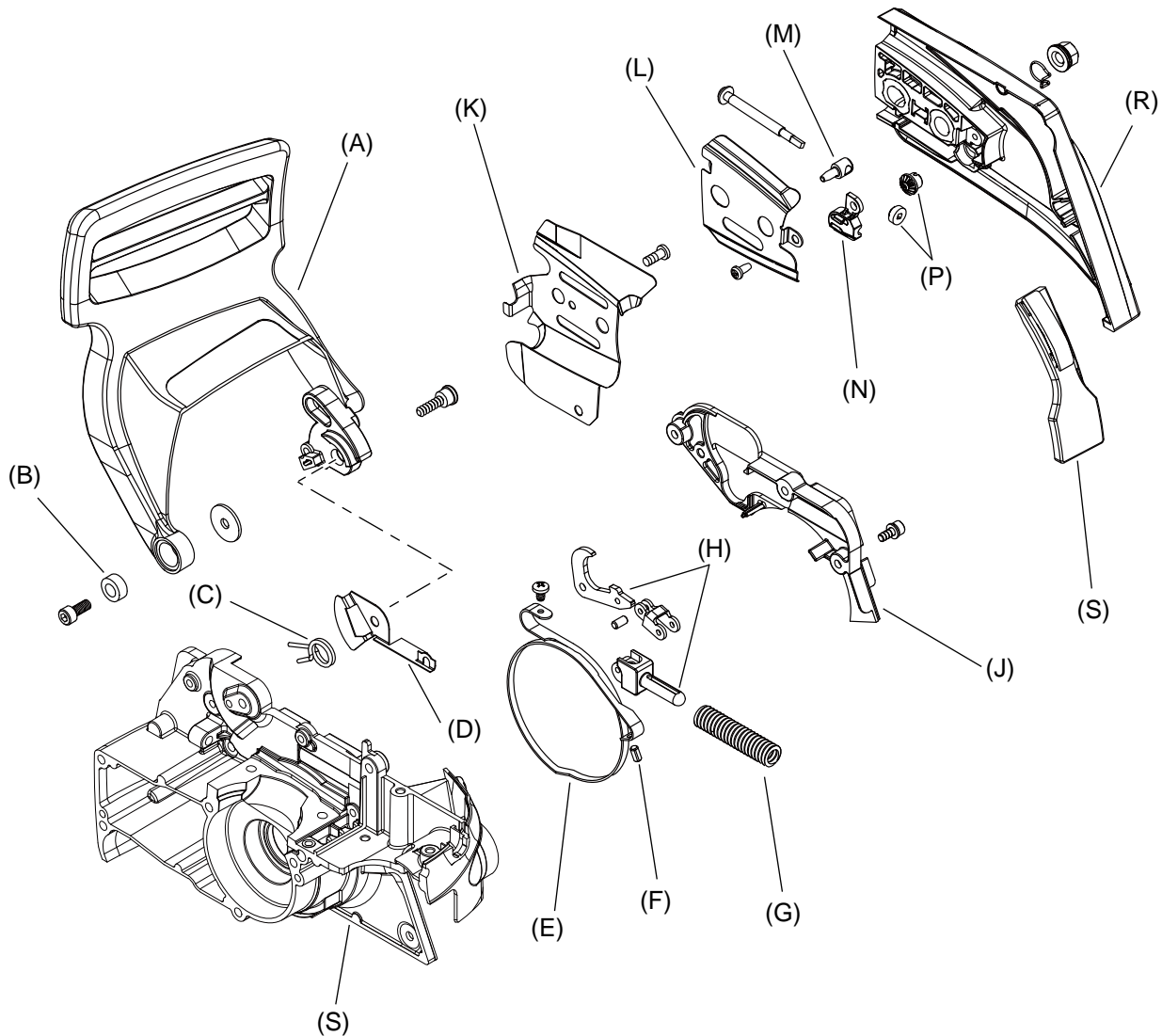

6-1 Disassembling chain brake

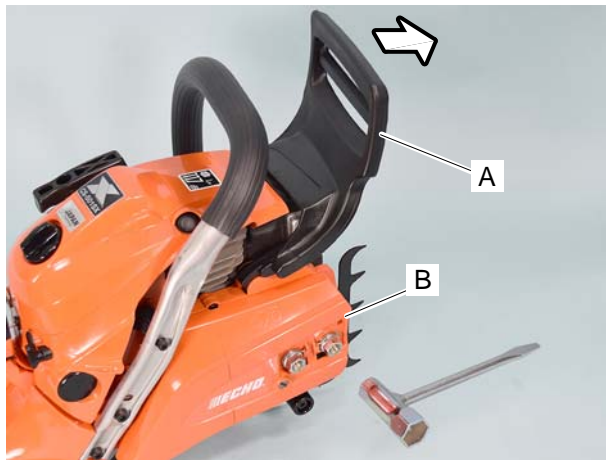

WARNING  **DANGER**
Wear eye protection and safety gloves when disassembling or assembling chain brake to protect eye and hand from injury.

1. Move brake lever (A) to chain brake engaging position.
2. Remove sprocket guard (B).

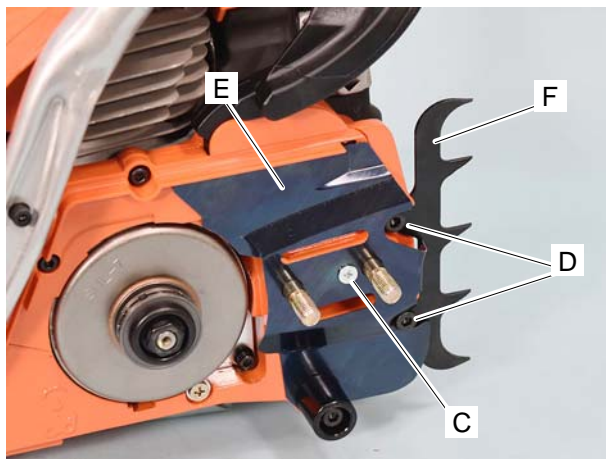

3. Remove screw (C) and two bolts (D) to remove sprocket guard plate (E) and spike (F).

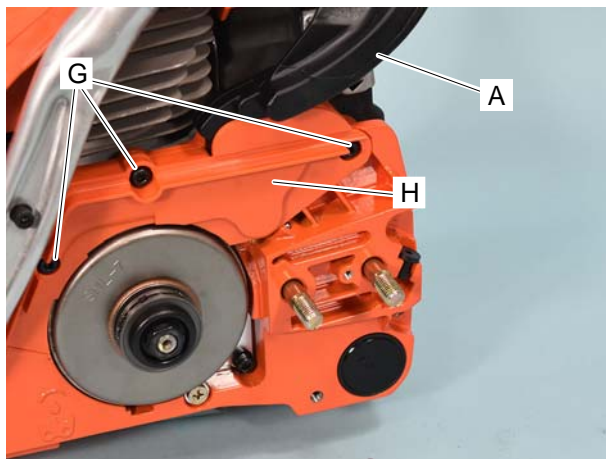

4. Remove three bolts (G) and brake cover (H).
5. Inspect all the brake parts for damage. Replace them as required.
6. Remove brake lever (Refer to "7-2 Inspecting auto-oiler assembly and oil line").
7. Inspect the brake lever for damage. Replace it as required.

6-2 Assembling brake parts

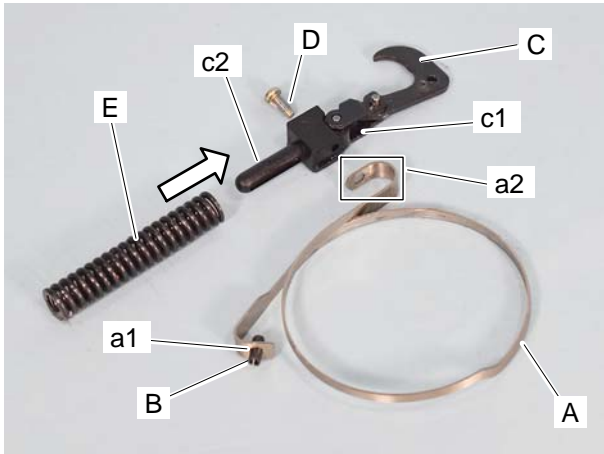

1. Install spring pin (B) through hole (a1) of brake band (A). Hook end (a2) of brake band (A) through hole (c1) of brake connector (C). Tighten brake band (A) and brake connector (C) with screw (D). Slide in coil spring (E) to the end (c2) of brake connector (C).

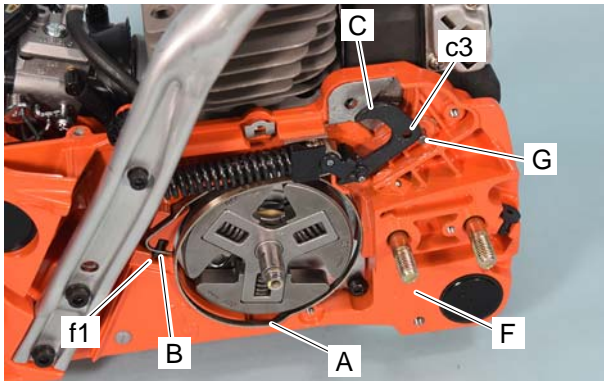

2. Install brake band (A) and other parts (Refer to the above 1.) on crankcase (F) as shown. Make sure the pin (B) in brake band (A) is engaging with the groove (f1) of crankcase.

3. Install boss (G) through hole (c3) of brake connector (C).

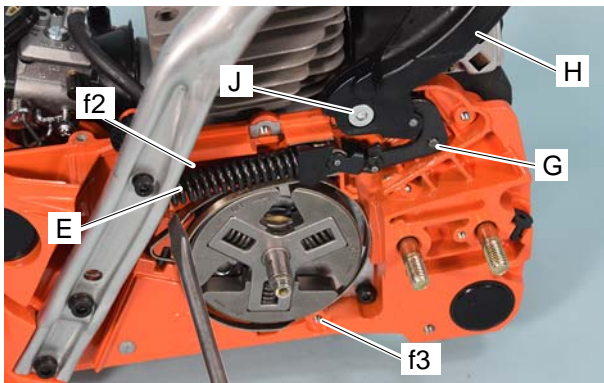

4. Set brake lever (H) with bolt (J).

5. Set the end of coil spring (E) on crankcase groove (f2) by pushing with flat head screwdriver as shown.

6. Tighten screw (K) and washer (L) in hole (f3) of crankcase.

7. Set brake lever (H) with bolt (M) and collar (N) on flywheel side.

8. Apply molybdenum grease on entire compression spring and other friction parts.

9. Reinstall guide plate, brake cover and other parts.

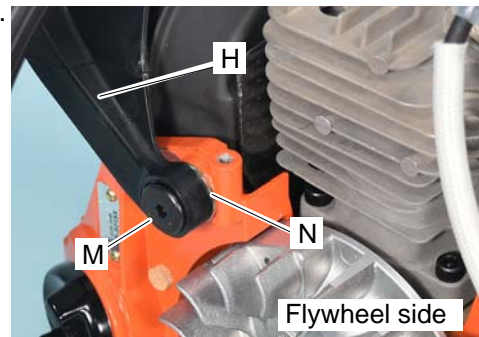
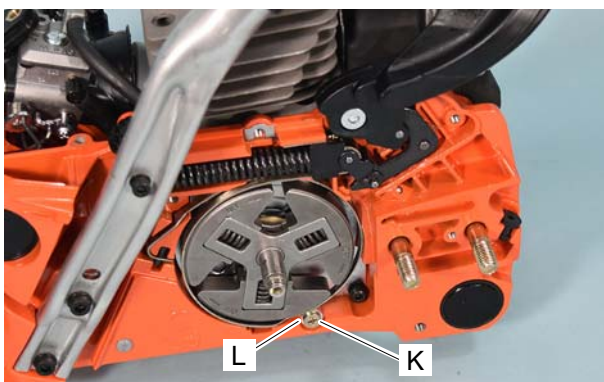

Flywheel side

7 SAW CHAIN LUBRICATION SYSTEM

- (A) Oil cap
- (B) O-ring
- (C) Connector
- (D) Oil tank vent
- (E) Crankcase
- (e) Oil tank
- (F) Oil strainer
- (G) Oil line
- (H) Auto-oiler assembly
- (J) Oiler cover

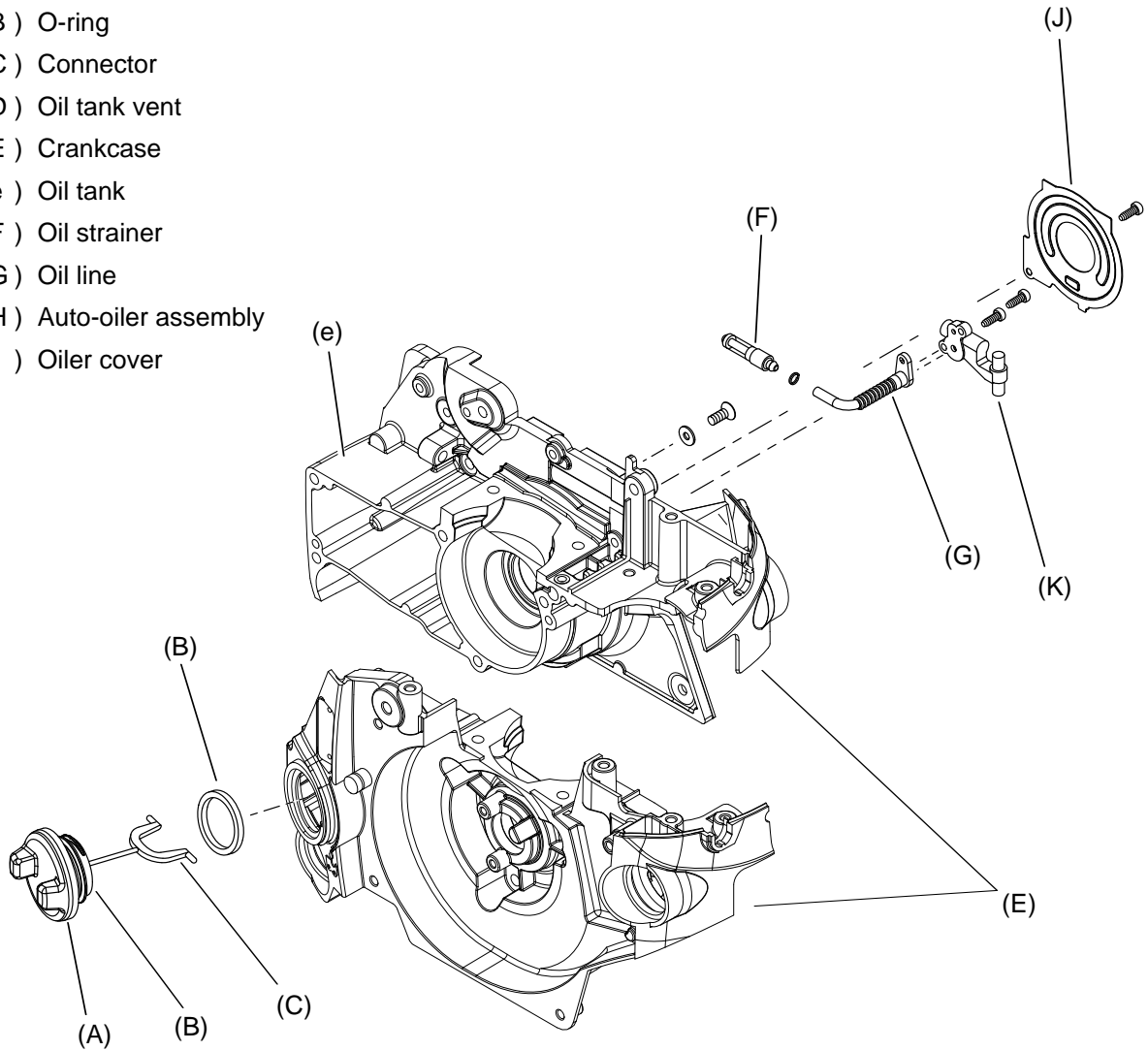

7-1 Inspecting oil cap and strainer

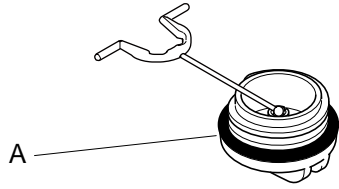

1. Remove oil cap.

2. Inspect oil cap for cracks and O-ring (A) for cuts or damage. Replace worn or damaged parts as required.

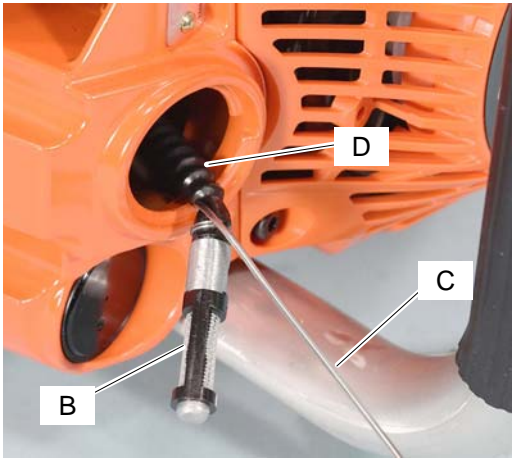

3. Pull oil strainer (B) from oil tank using a wire hook (C).

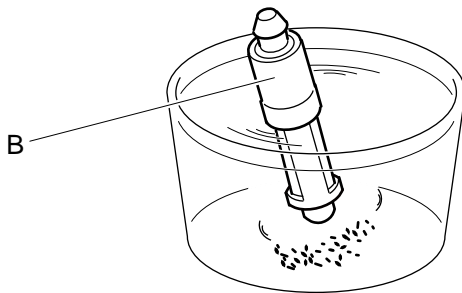

4. Remove oil strainer (B) from oil line (D) and clean oil strainer in suitable solvent, or replace if damaged.

7-2 Inspecting auto-oiler assembly and oil line

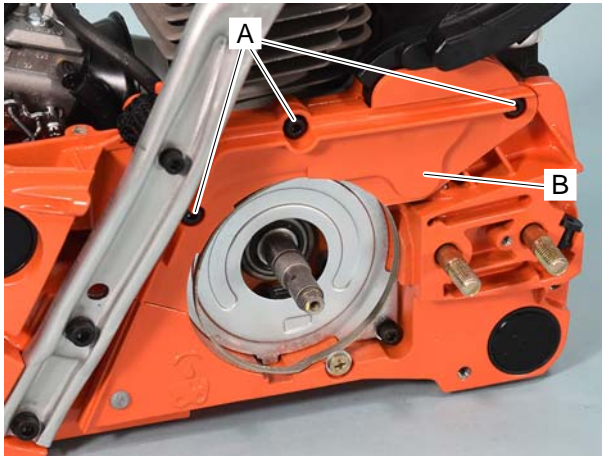

1. Remove three bolts (A) and brake cover (B).

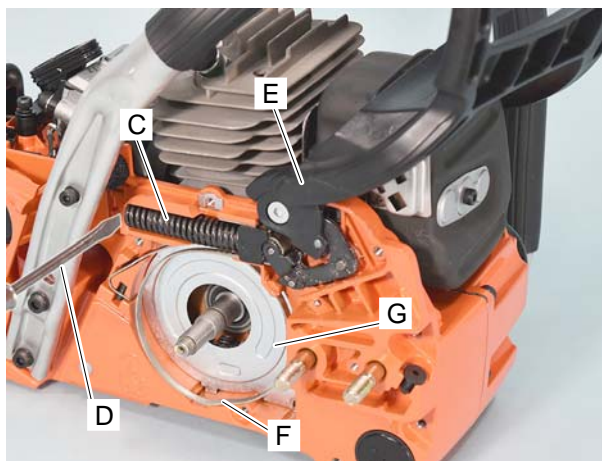

2. Remove coil spring (C) using flat head screwdriver (D).

3. Remove brake lever (E), coil spring (C), brake band (F), oiler cover (G) and related parts.

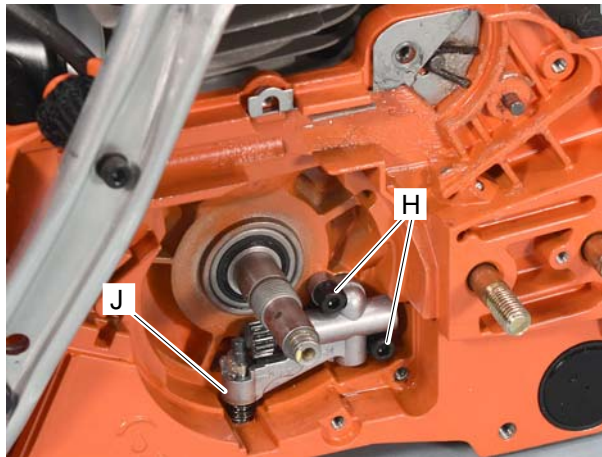

4. Remove two bolts (H) and auto oiler assembly (J).

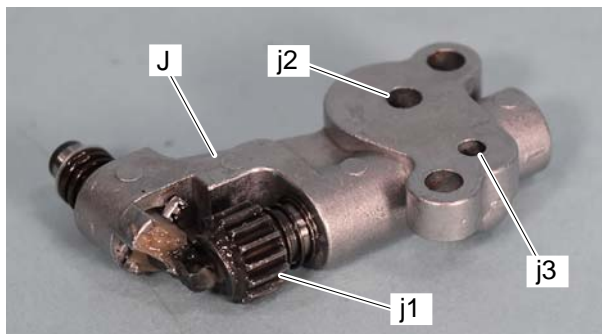

5. Inspect auto-oiler assembly (J) for discoloration or deformation. Inspect gear (j1) for wear, damage and rotate smoothly. Inspect oil inlet (j2) and outlet (j3) for clog. Replace as required.

7-3 Inspecting oil tank vent

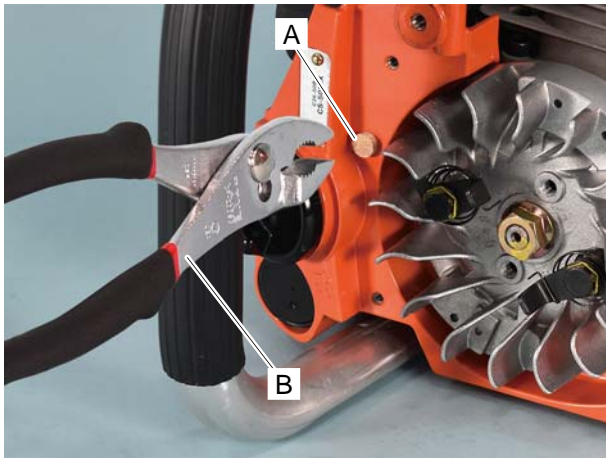

NOTE: Oil tank vent prevents a vacuum from forming in oil tank when chain oil in the tank is consumed.

1. Inspect oil tank vent (A) for clog or deformation. Replace as required.

2. Remove oil tank vent (A) using pliers (B).

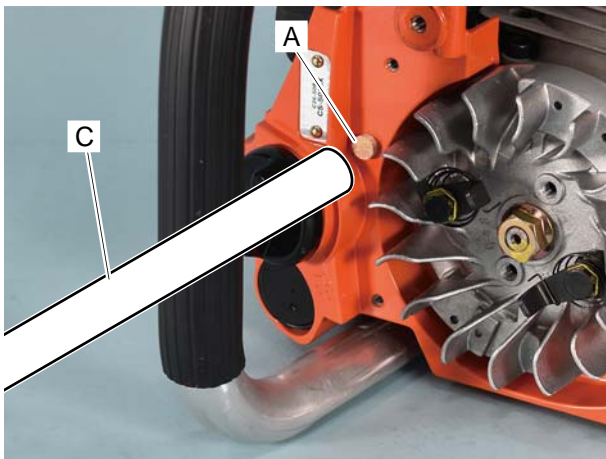

3. Install oil tank vent (A) using suitable tool (C) as shown.

8 ENGINE

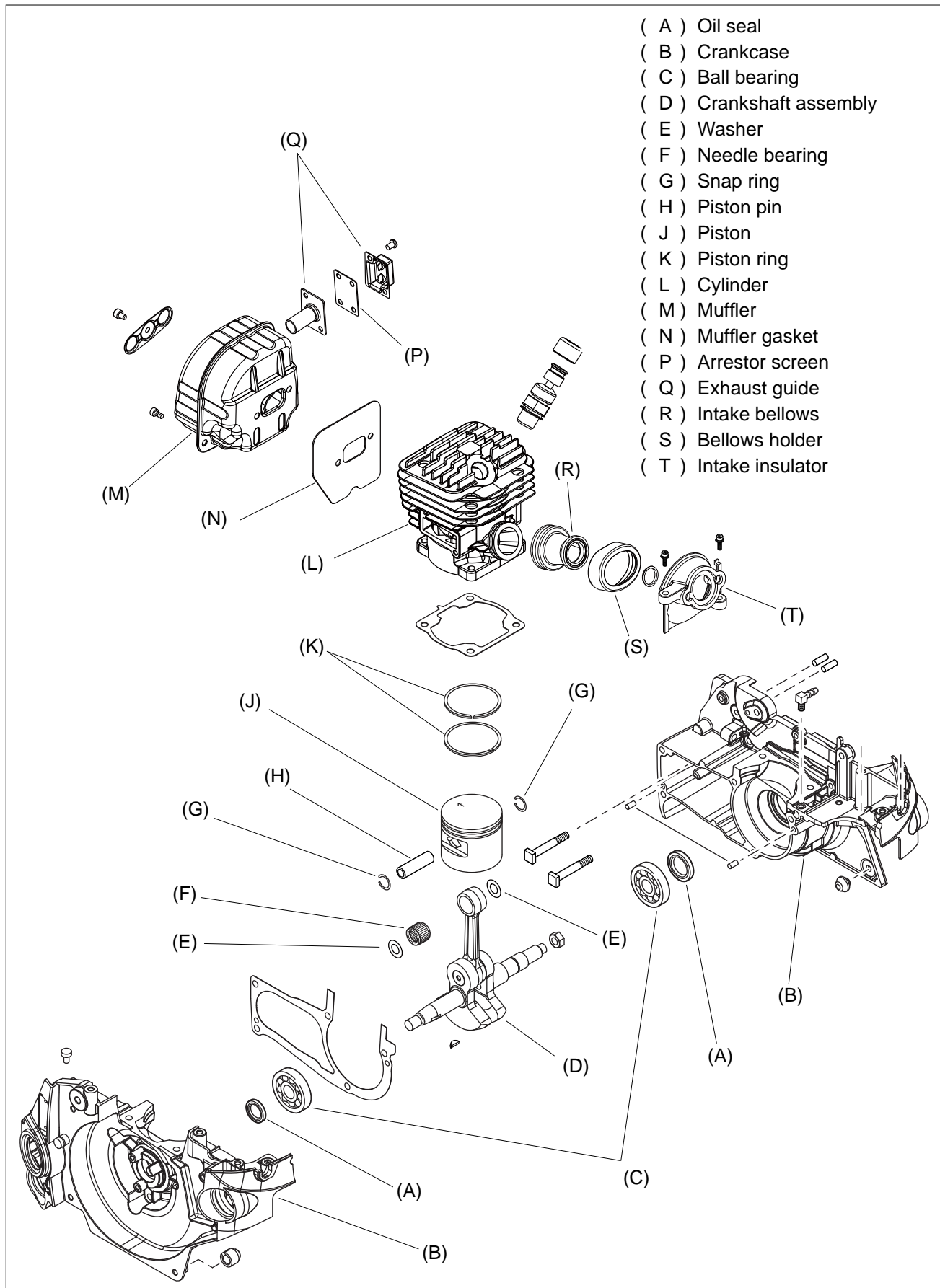

8-1 Testing cylinder compression

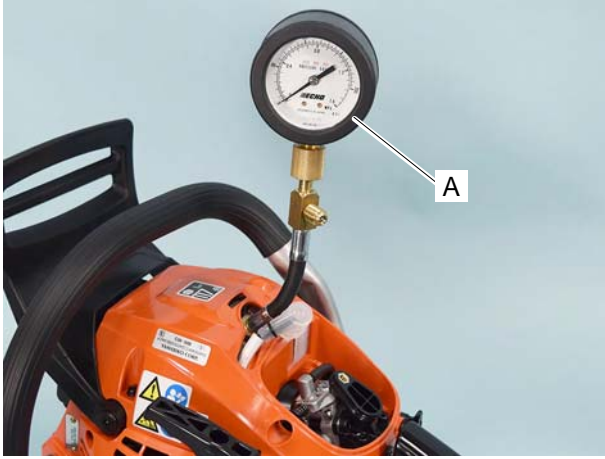

NOTE: Test cylinder compression when engine is cold.

1. Move ignition switch to STOP position. Then remove spark plug.
2. Install Compression gauge 91037 (A) in spark plug hole and tighten by hand. Pull starter several times to stabilize reading on compression gauge.
3. If pressure is lower than approx. 75% of standard compression pressure (Refer to "1-2 Technical data"), inspect cylinder bore, piston, and piston ring for wear or damage.

4. If pressure is more than approx. 125% of standard compression pressure, inspect cylinder combustion chamber and exhaust port, piston crown, and muffler for carbon deposits.

NOTE: Compression pressure varies with volume of compression gauge tip occupying cylinder combustion chamber. If gauge tip volume is considerably different from spark plug volume, it is recommended to measure and note compression pressure of brand-new engines as standard pressure in advance.

8-2 Cleaning cooling air passages

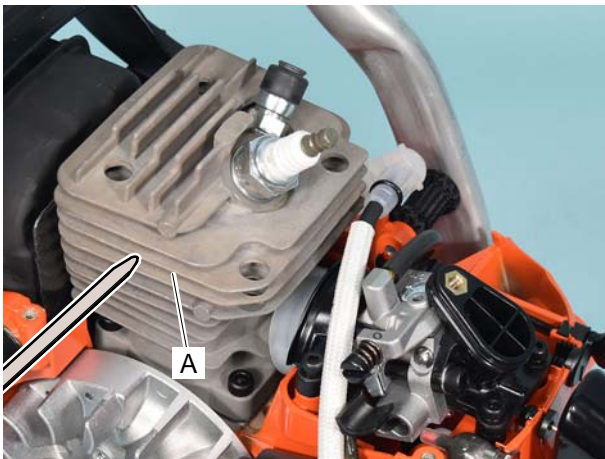

1. Remove cleaner lid, air filter and cylinder cover. Remove starter assembly (Refer to "2-1 Disassembling starter assembly").

WARNING  **DANGER**

Always wear eye protection when using compressed air for cleaning. Otherwise, eye damage can occur from flying particles.

2. Inspect cylinder cooling fins (A) for blockage with dirt and/or saw dust. Clean them with wooden or plastic stick or compressed air as required.
3. Install all removed parts.

8-3 Inspecting muffler and exhaust port



1. Remove cleaner lid, air filter and cylinder cover.
2. Remove muffler with muffler gasket.
3. Inspect cylinder exhaust port and clean the port using wooden or plastic stick if carbon is found.

NOTE: When cleaning exhaust port, always position piston at Top Dead Center (TDC) to prevent carbon from entering cylinder. Do not use metal tool, and be careful not to scratch piston or cylinder.

NOTE: Replace muffler gasket with new one when removing muffler.

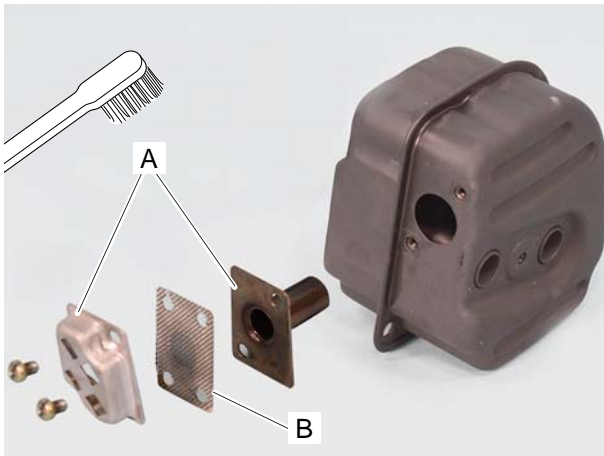

4. Remove exhaust guides (A) and spark arrestor screen (B) from muffler.
5. Remove carbon deposits from spark arrestor screen and exhaust guides. If screen has heavy deposits, replace with new one.
6. Reinstall spark arrestor screen and exhaust guides to muffler.

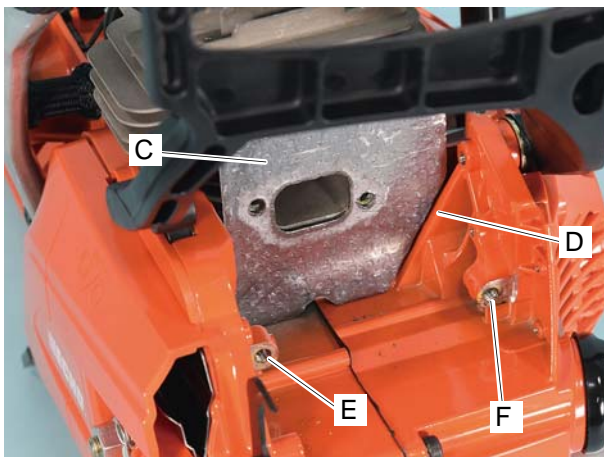

7. Reinstall muffler with new muffler gasket.
- NOTE:** Before reinstalling muffler, apply 2-stroke oil on muffler gasket surface and temporarily paste muffler gasket (C) on cylinder as shown, in order to avoid damage to muffler gasket from wall (D) of crankcase.

NOTE: New bolts for bolt hole (E) and (F) are pre-coated with sealant on the thread. If the sealant is peeled off, apply thread locking sealant (Loctite #242, ThreeBond #1324 or equivalent).

8-4 Testing crankcase and cylinder seal

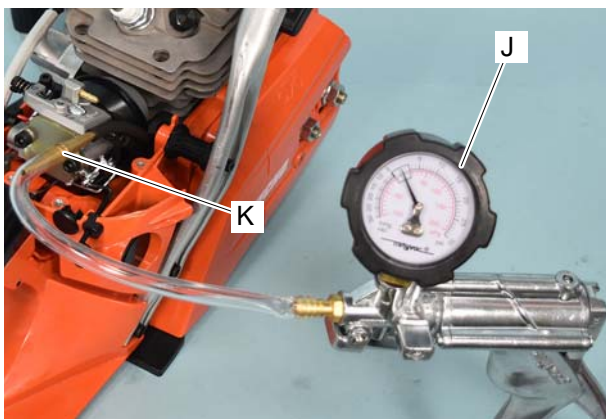
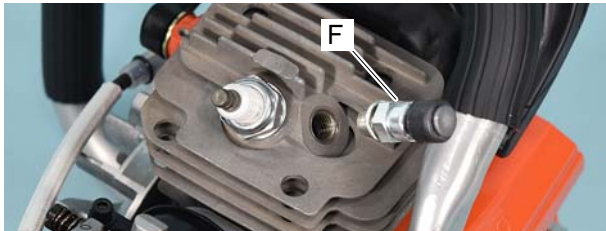
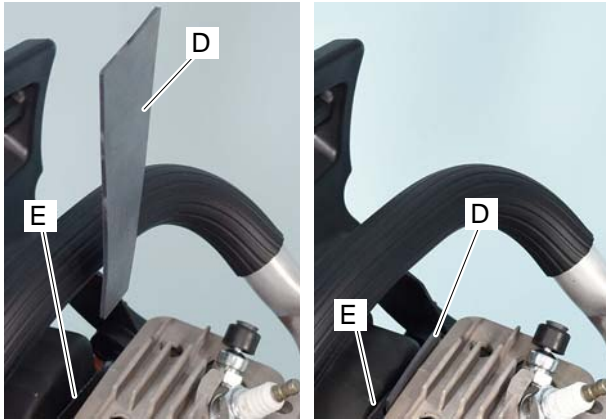
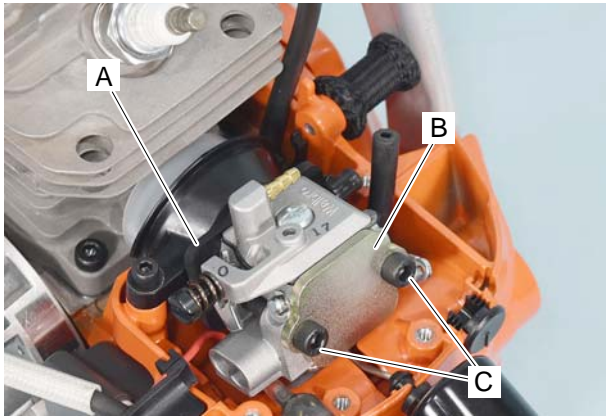

1. Remove cleaner lid, air filter and cylinder cover.

2. Disconnect fuel line, pulse line and choke rod from carburetor, and remove carburetor from the unit.

3. To seal intake port, install Pressure rubber plug 897826-16131 (A) between intake insulator and carburetor, using carburetor screws (C). Install Pressure plate 897827-16131 (B) between carburetor and screw heads as spacer. Tighten screws (C).

4. Loosen 4 muffler bolts. To seal exhaust port, insert pressure rubber plug 91041 (D) between cylinder exhaust port and muffler gasket (E), until the rubber plug covers exhaust port.

5. Tighten upper 2 bolts of muffler.

6. Remove decompressor (F) and install plug 101115-37531 (G) and O-ring 900720-00009 (H) as shown.

7. Connect pressure / vacuum tester 91149 (J) to pulse line using provided pipe joint (K).

8. Apply pressure approx. 50 kPa (0.5 bar) (7.1 psi) by the tester (J).

9. If the pressure drops, leakage may occur.

10. Leakage may occur from crankcase seam, cylinder base, oil seal and spark plug. Use soapy water to locate leakage.

11. Apply negative pressure approx. 30 kPa (0.3 bar) (4.3 psi) by the tester (J).

12. If the pressure decreases, leakage may occur from oil seal. Inspect oil seal for damage or wear.

13. Remove pressure / vacuum tester (J), pipe joint (K) from pulse pipe. Remove pressure rubber plugs (A) (D) and pressure plate (B) from intake bellows and exhaust port. Remove plug (G) and O-ring (H) and install decompressor (F).

8-5 Inspecting cylinder

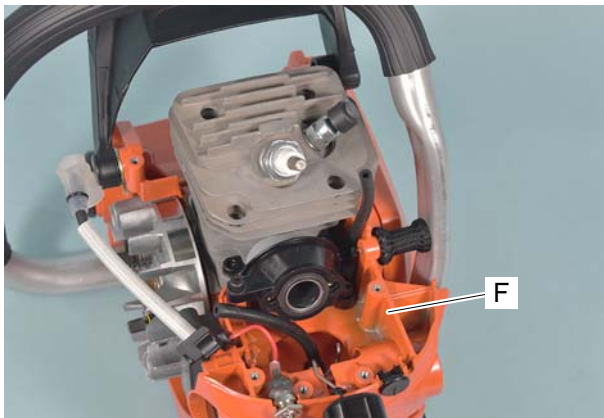
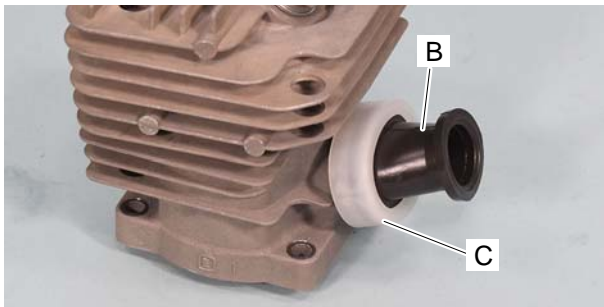
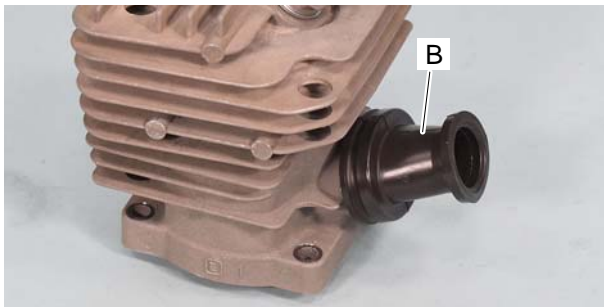
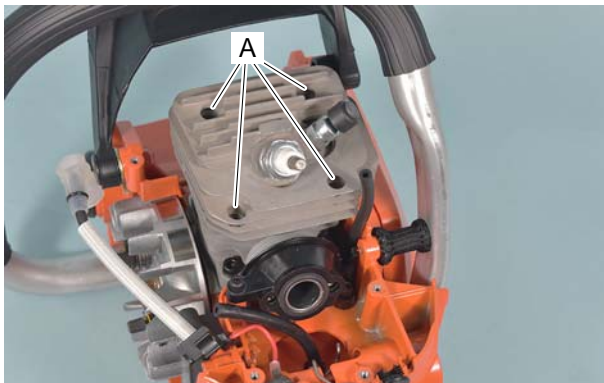

1. Remove carburetor from the unit (Refer to “4-5-1 Replacing fuel line”).
2. Remove muffler with muffler gasket (Refer to “8-3 Inspecting muffler and exhaust port”).
3. Remove 4 bolts from cylinder base through holes (A).
4. Inspect cylinder combustion chamber and clean with a plastic or wooden scraper if carbon is found.
NOTE: Do not use metal tools, or damage to cylinder wall may result.
5. Inspect cylinder wall and replace with new one if plating is worn, peeled away, scored or exposing cylinder base metal.
6. Install intake bellows (B) to cylinder.

7. Install bellows holder (C) on intake bellows (B).

8. Install intake insulator (D) on intake bellows (B).
9. Install collar (E) in intake bellows (B).

10. Install cylinder in crankcase (F).

8-6 Inspecting piston and piston ring

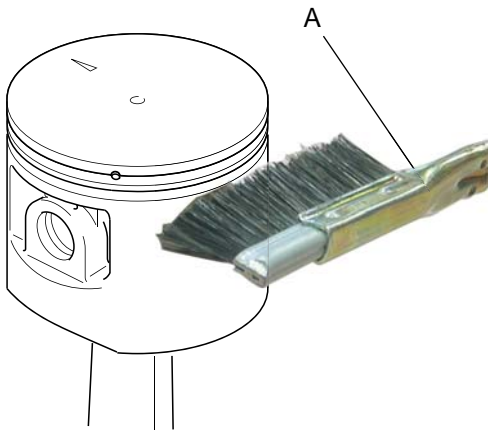

1. Inspect piston ring and replace it if broken or scored, or if it exceeds service limits (Refer to “1-5”).

2. Inspect piston crown. Clean with fine sand paper, oil stone, or soft cleaning brush (A) if carbon is found.

3. Inspect top land, ring groove and skirt. Clean them with soft cleaning brush (A) if carbon is found.

NOTE: Do not use square end of broken piston ring when cleaning piston ring groove, otherwise piston ring groove might be damaged.

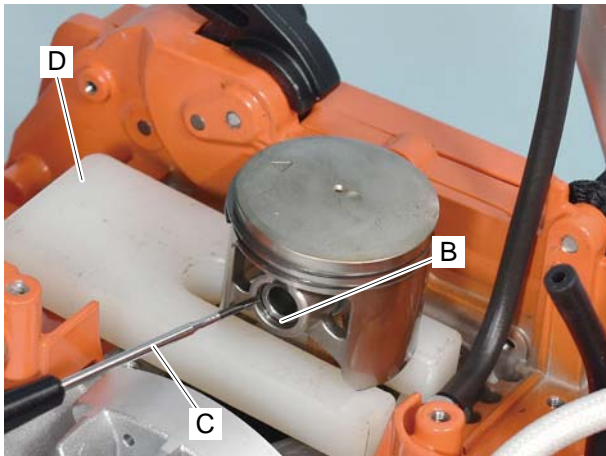

4. Remove snap ring (B) from both sides of piston pin, using small flat head screwdriver (C).

NOTE: Piston holder 897719-02830 (D) is recommended.

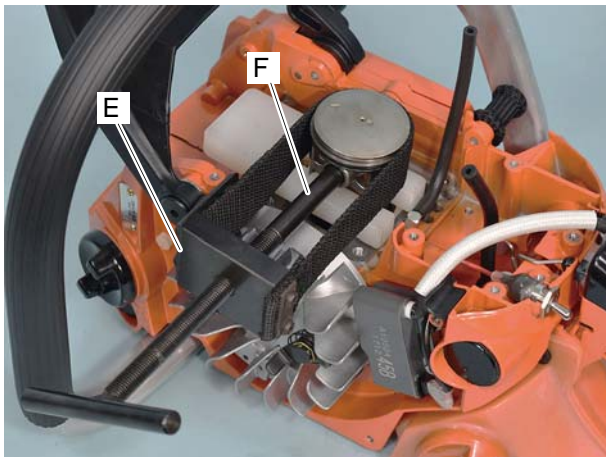

5. Push piston pin out from piston.

NOTE: If piston pin is tight, use Piston pin tool 897702-30131 (E) with adapter (F) stamped “11” on an end.

6. Inspect needle bearing and washers, and replace if wear or discoloration is noted.

8-7 Replacing oil seal

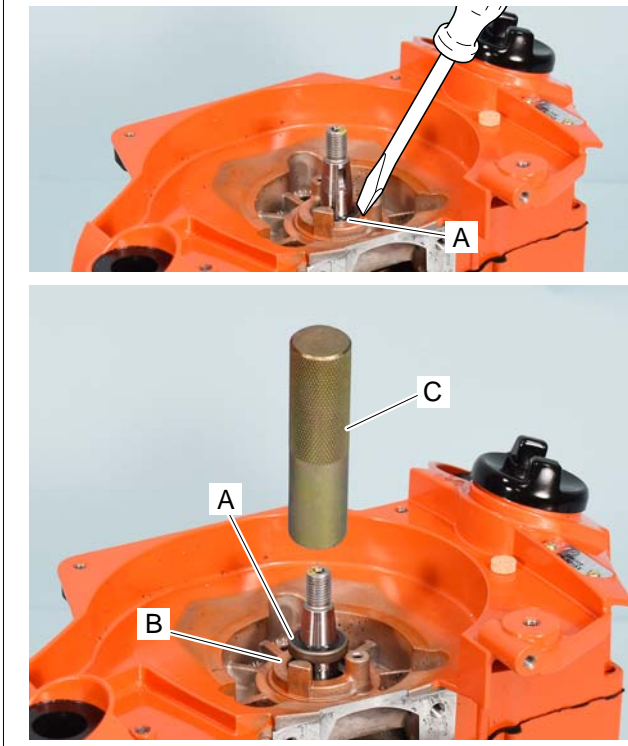

1. Pry oil seal from crankcase.

NOTE: Be careful not to damage crankshaft and oil seal housing.

NOTE: Before removing flywheel side oil seal, remove woodruff key.

2. Remove oil seal (A) using flat head screwdriver.

3. Apply lithium based grease, ECHO XTended Protection Lubricant or Red Armor Lubricant on inner rubber lips of new oil seal.

4. Lubricate circumferences of new oil seal with high melting point grease.

5. Push in new oil seal (A) until flush with crankcase surface (B) using Oil seal tool X646-000360 (C).

8-8 Disassembling crankcase

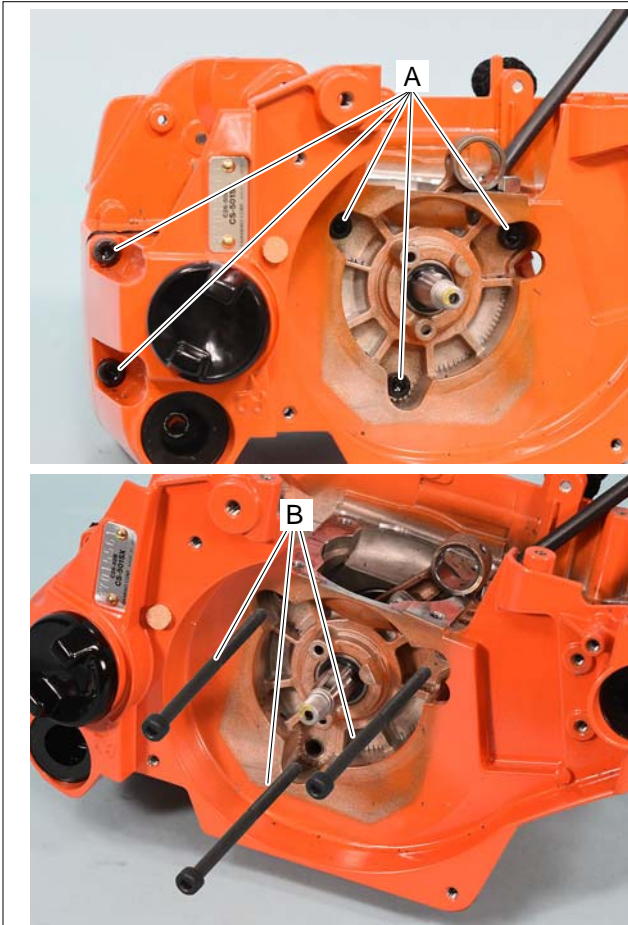

1. Referring to “11-1 Disassembly chart”, remove necessary parts for crankcase disassembly.

2. Remove 5 bolts (A) from crankcase.

3. Install long 3 bolts (B) (length: approx. 80 mm) on one side of crankcase halves (in the picture, flywheel side is shown).

4. Tighten bolts (B) to pull crankcase halves apart.

5. Crankshaft remains on the other side of crankcase halves, and can be removed by the same procedure with long 3 bolts (B).

6. Clean and inspect crankshaft and crankcase for damage and discoloration.

8-9 Replacing ball bearing and oil seal

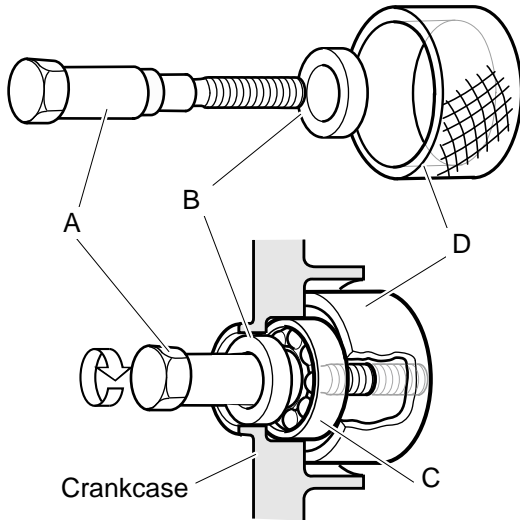

1. After disassembling crankshaft, check ball bearing for smooth rotation. If rough, replace it (them) with new one.

NOTE: At the same time, replace oil seal with new one.

2. Remove ball bearing from crankcase half using bearing tool 897701-14732 as follows.

3. Set shaft (A) through oil seal (B) and ball bearing (C), with boss (D) as shown.

4. Tighten shaft (A) with wrench to remove ball bearing (C) and Oil seal (B).

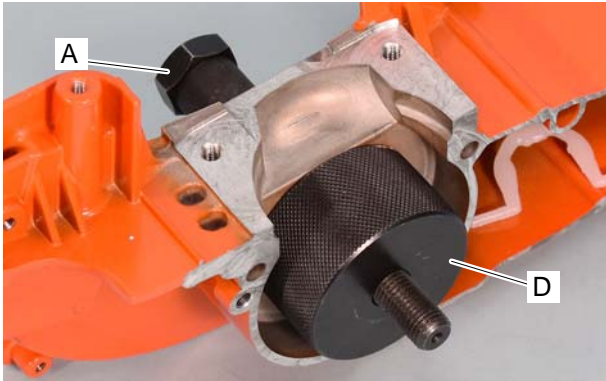

5. Coat bearing housing in crankcase with a lithium based grease.

6. Set ball bearing with shaft (A), adapter (G) (inner dia. 15 mm, outer dia. 40 mm) and boss (D).

NOTE: Set adapter (G) mating full flat side (g) to ball bearing.

7. Tighten shaft (A) with wrench to press ball bearing into the crankcase half until flush.

8. Check that bearing rotates smoothly.

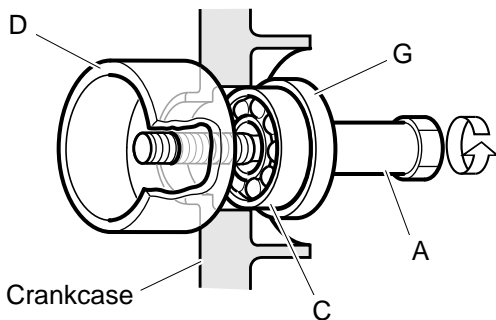
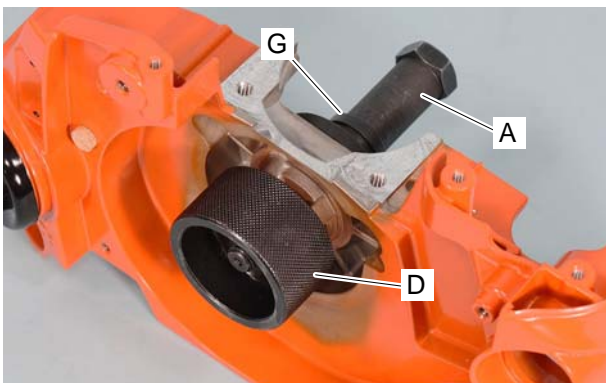

8-9 Replacing ball bearing and oil seal (continued)

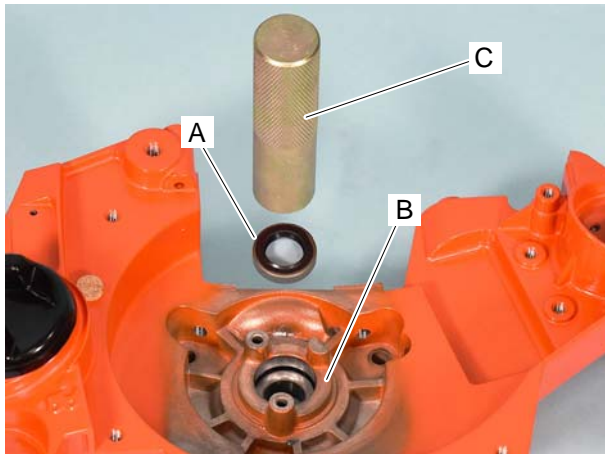

9. Apply lithium based grease, ECHO XTended Protection Lubricant or Red Armor Lubricant on inner rubber lips of new oil seal.

10. Lubricate circumferences of new oil seal with high melting point grease.

11. Push in new oil seal (A) until flush with crankcase surface (B) using Oil seal tool X646-000360 (C).

8-10 Assembling crankshaft and crankcase

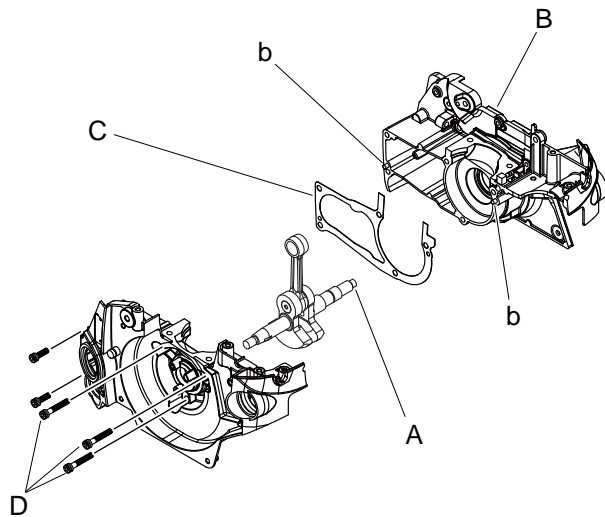

1. Clean mating surface of each crankcase half.

2. Insert crankshaft clutch end (A) into clutch side crankcase half (B) until properly seated.

NOTE: If it is hard to insert crankshaft to crankcase, preheat ball bearing for easier installation.

3. Put new crankcase gasket (C) on clutch side crankcase half (B).

4. Reassemble both crankcase halves together ensuring that dowel pins (b) on clutch side crankcase half (B) are properly seated in holes on the other half.

5. Tighten 3 bolts (D) diagonally to secure crankcase halves together, and check crankshaft for smooth rotation.

6. Tighten other 2 bolts.

NOTE: Tighten bolts referring to "1-3 Torque limits".

8-11 Installing piston

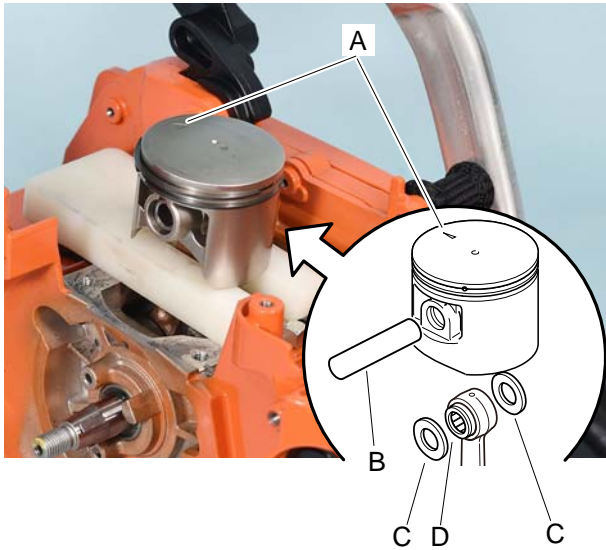

1. Place piston over the small end of connecting rod, so that the arrow mark (A) on piston points front as shown.

2. Insert piston pin guide (B) stamped "11", through piston, washers (C) and needle bearing (D) in connecting rod as shown.

NOTE: Piston pin guide (B) is included in piston pin tool 897702-30131.

3. Insert piston pin (E) in piston pushing out piston pin guide (B) using piston pin tool 897702-30131 (G) and Piston holder 897719-02830 (F).

4. Install new snap rings to piston using small flat head screwdriver and be sure that they are correctly seated in the grooves.

NOTE: If it is hard to install snap rings, modify flat head screwdriver end as shown to hook snap ring.

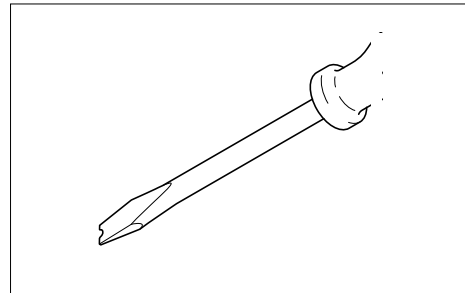
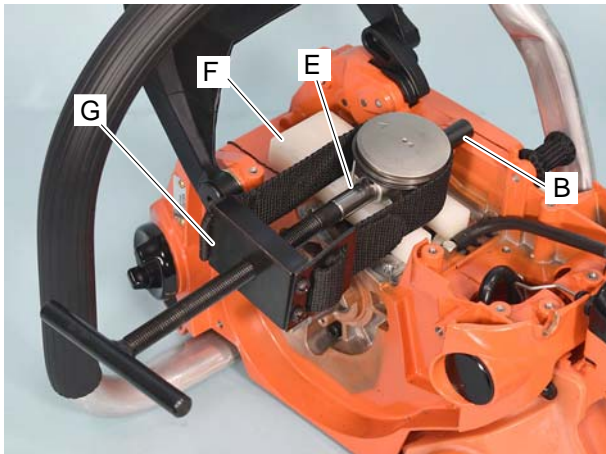

8-12 Installing piston ring and cylinder

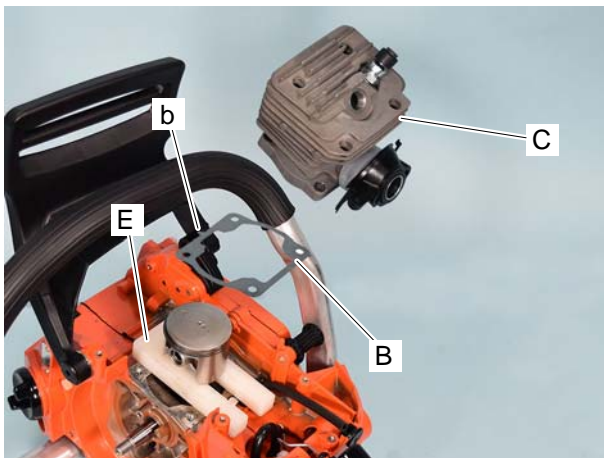
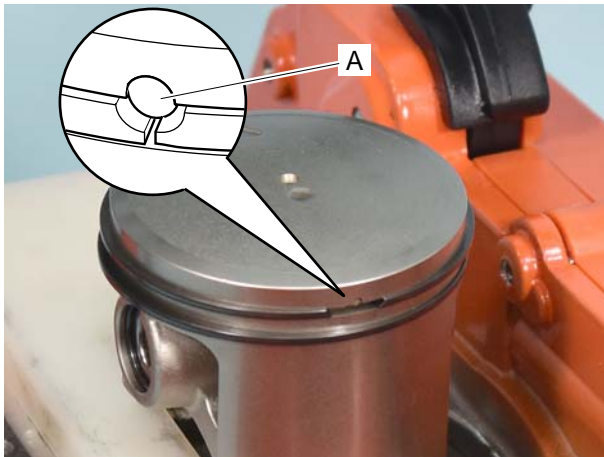

1. Install piston ring on piston, ensuring the end gaps of piston ring are properly positioned around locating pin (A) as shown.

2. Temporarily paste new cylinder gasket (B) on cylinder base with a little glue for easier installation of cylinder.

NOTE: Projection (b) of cylinder gasket (B) is towards brake lever side.

3. Apply oil to piston ring and internal wall of cylinder.

4. Install cylinder (C) with intake bellows, bellows holder and intake insulator with over piston, ensuring that the exhaust side of cylinder should face front as shown.

NOTE: When installing cylinder, it is convenient to use Piston holder 897719-02830 (E) to stabilize piston.

NOTE: When installing piston in cylinder, do not twist cylinder to avoid breakage of piston ring and scoring cylinder bore.

5. Reinstall all removed parts in place.

9 REAR HANDLE AND CONTROL SYSTEM

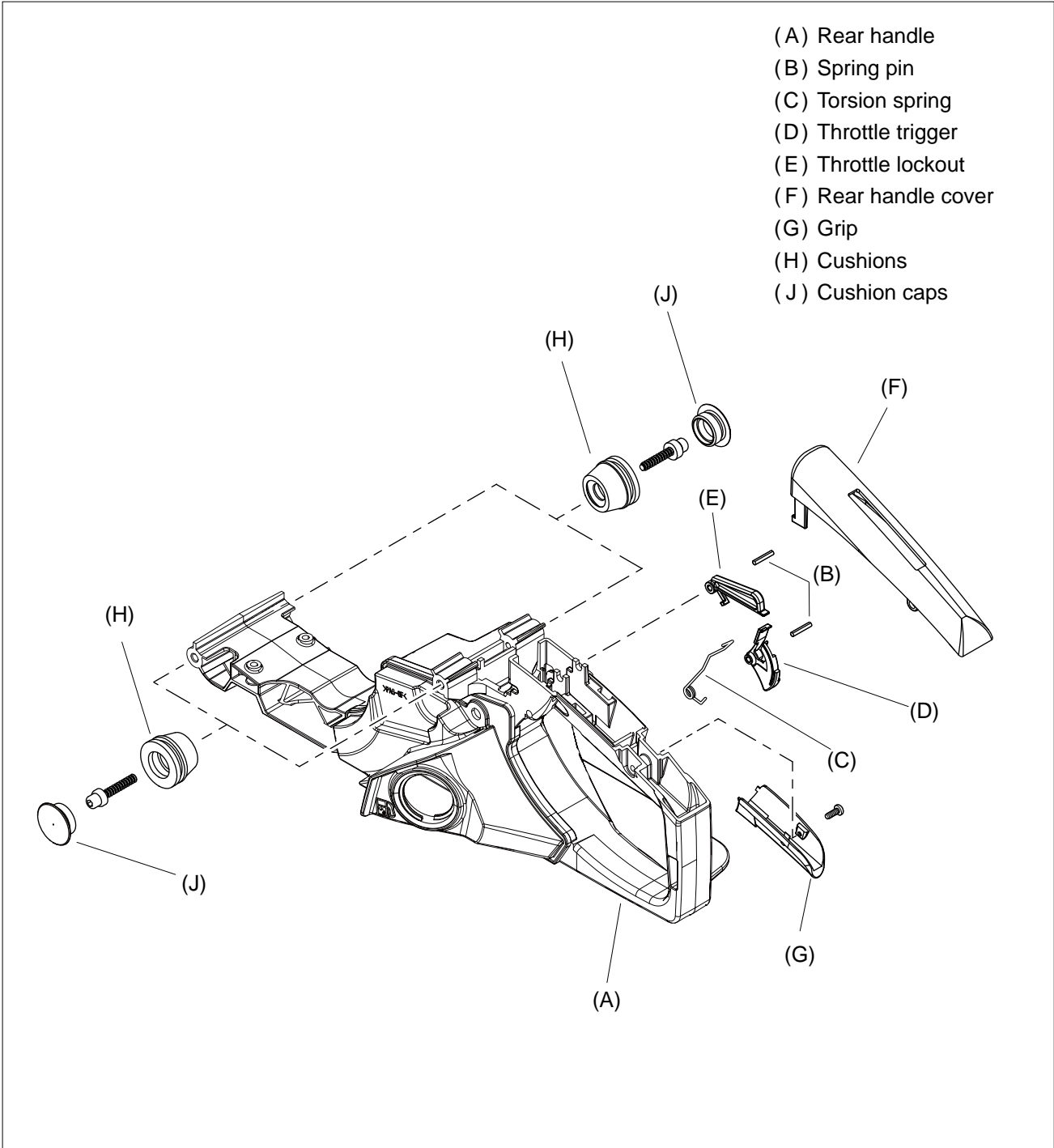

9-1 Replacing cushions

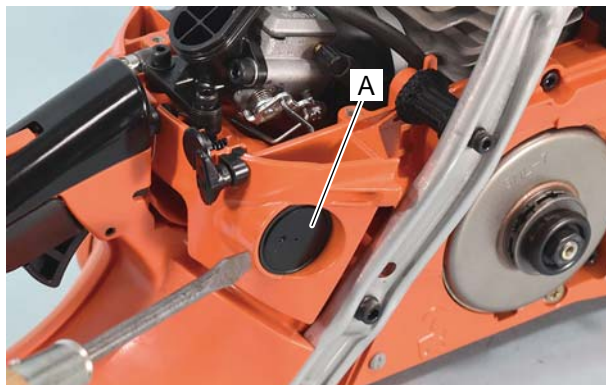

1. Remove four cushion caps (A) (Refer to cushion caps (J) of "9 REAR HANDLE AND CONTROL SYSTEM" on previous page).

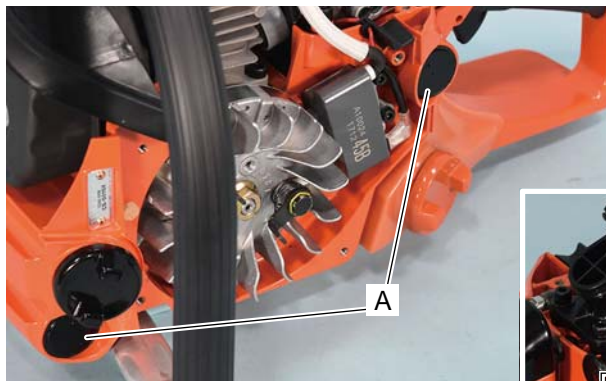

2. Remove a bolt (B), four cushion caps (A), four bolts (C) under cushion caps (A) and rear handle from unit.

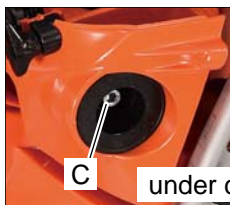

under cushion cap

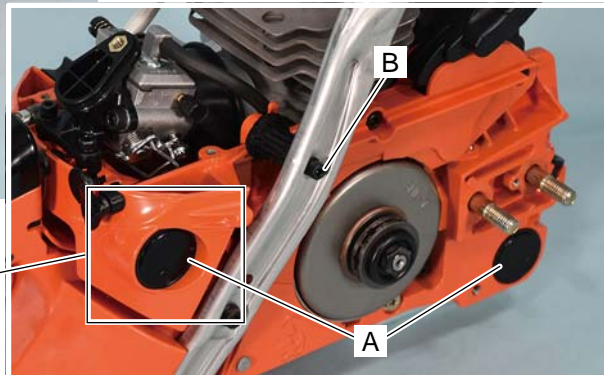

3. Inspect cushions (D) for cracking and wear. If damaged replace with new cushions as follows.

4. To remove cushions (D), push by hand in direction of arrows.



5. Install new cushions by pushing in direction of arrows.

9-1 Replacing cushions (continued)

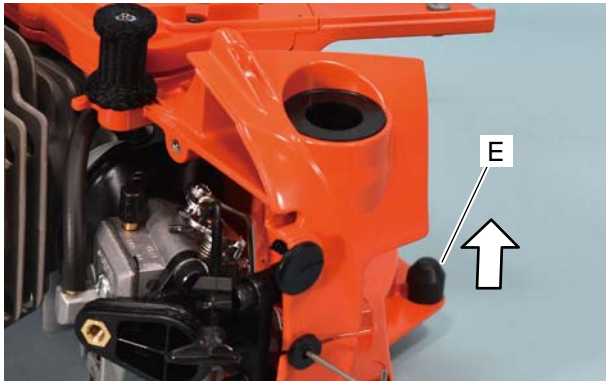

6. Inspect cushions (E) for cracking or wear. If damaged, replace with new cushions as follows.

7. To remove cushions (E), pull by hand in direction of arrows.

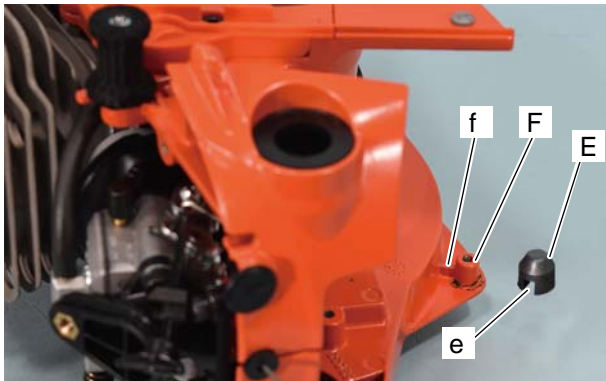

8. Clean the surrounding of cushion boss (F) if adhesive is struck.

9. Install new cushion (E) mating groove (e) to projection (f) of the boss (F).

10. Apply adhesive Loctite 422 or equivalent to the base of cushion (E).

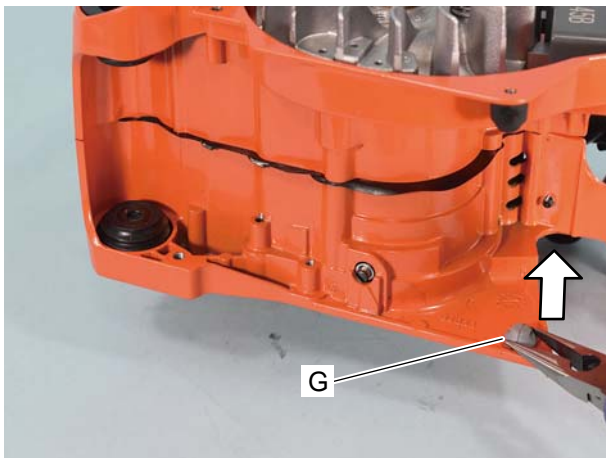

11. Inspect cushions (G) for cracking or wear. If damaged, replace with new cushions as follows.

12. To remove cushions (G), pull by hand in direction of arrows.

13. Clean the surrounding of cushion hole (H) if adhesive is struck.

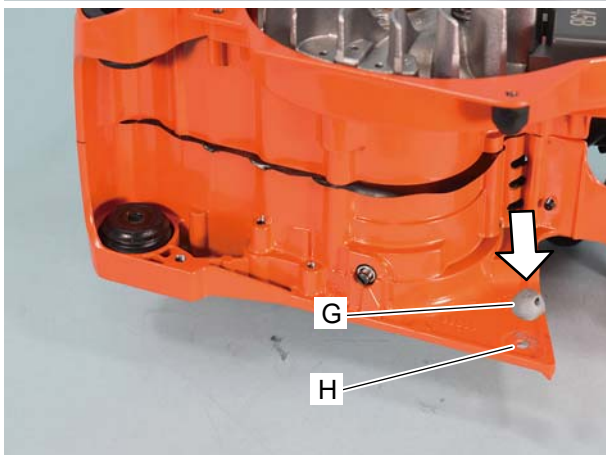

14. Install new cushion (G) by pushing in direction of arrows.

15. Apply adhesive Loctite 422 or equivalent to the base of cushion (G).

16. Reassemble rear handle to the unit. Reassemble all related parts.

9-2 Replacing throttle trigger

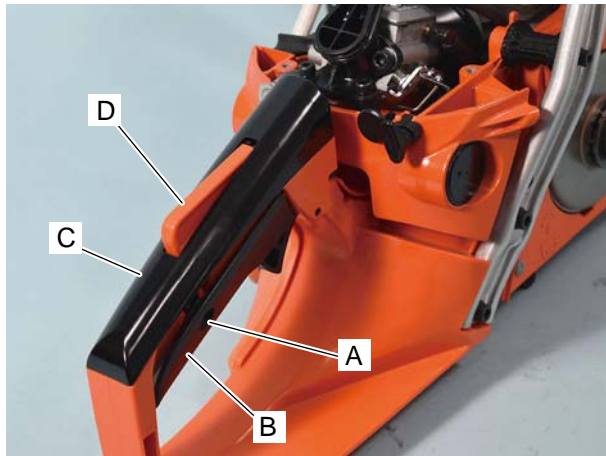

1. Loosen screw (A) and remove grip (B), rear handle cover (C) and throttle lockout (D).

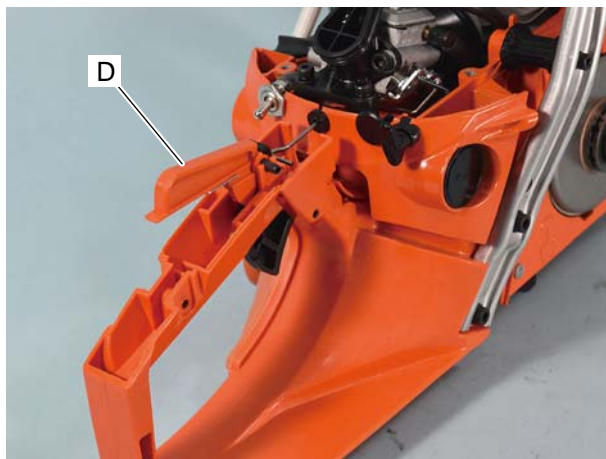

2. Inspect grip (B), rear handle cover (C) and throttle lockout (D) for cracking or wear. If damaged, replace it as required.

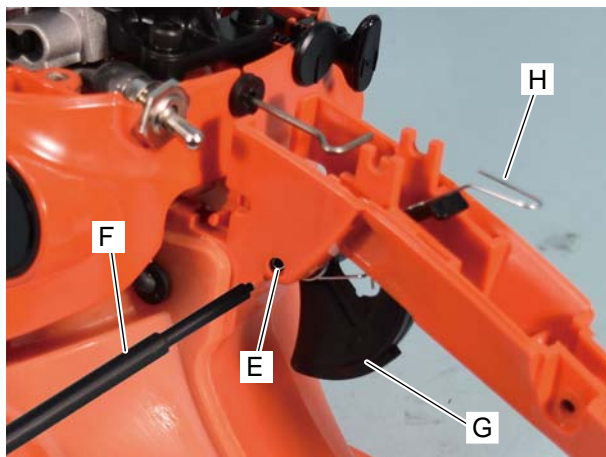

3. Push out spring pin (E) from rear handle using Spring pin tool 897724-01361 (F).

4. Remove throttle trigger (G) together with torsion spring (H).

9-2 Replacing throttle trigger (continued)

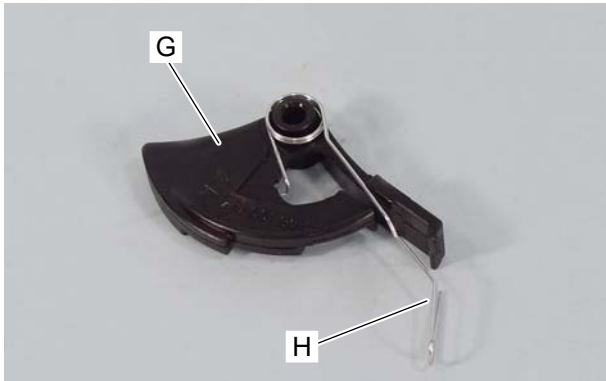

5. Set torsion spring (H) on throttle trigger (G) as shown.

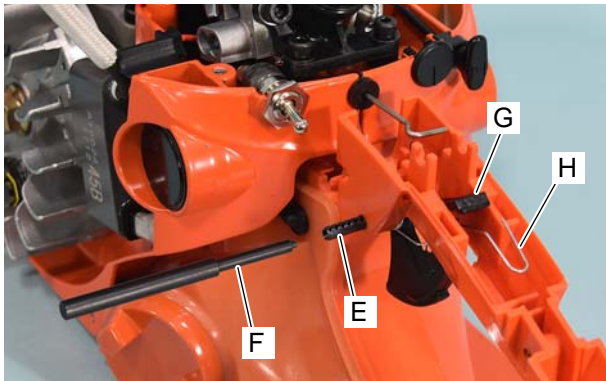

6. Install throttle trigger (G) with torsion spring (H) and insert spring pin (E) as follows.

1) Insert spring pin (E) in the hole of rear handle so the tip of spring pin does not protrude inside handle.

2) Align spring pin (E) and the hole of throttle trigger (G) with torsion spring (H), and insert spring pin (E) in the hole of throttle trigger (G).

3) Lightly tap in spring pin (E), using spring pin tool 897724-01361 (F).

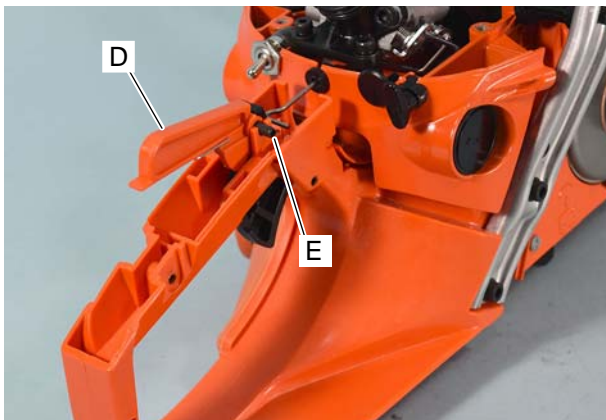

7. Install throttle lockout (D) with spring pin (E) as shown.

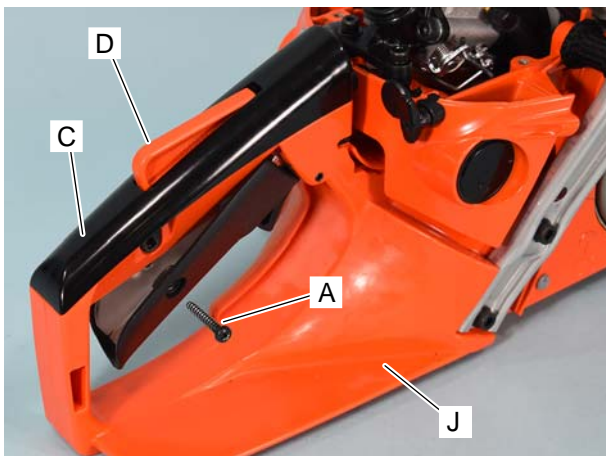

8. Install rear handle cover (C) on rear handle (J), setting torsion spring (H) with throttle lockout (D) as shown (Refer to "9-3-3 Replacing rear handle heater").

9. Tighten screw (A) to secure rear handle cover (C). Check throttle trigger (G) and throttle lockout (D) for correct movement.

9-3 Service hint for heated handle (CS-501SXH only)

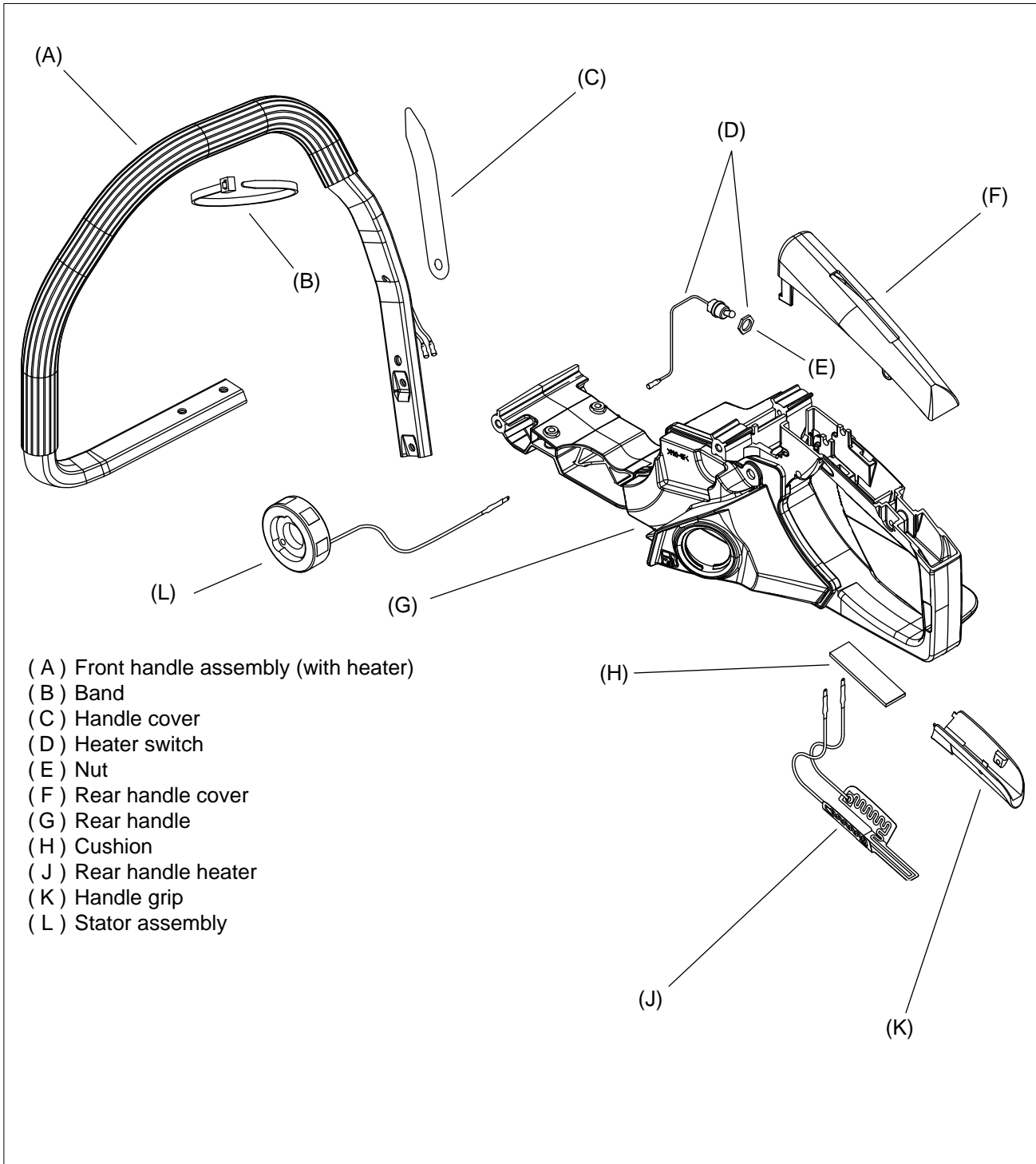

9-3-1 Inspecting heated handle

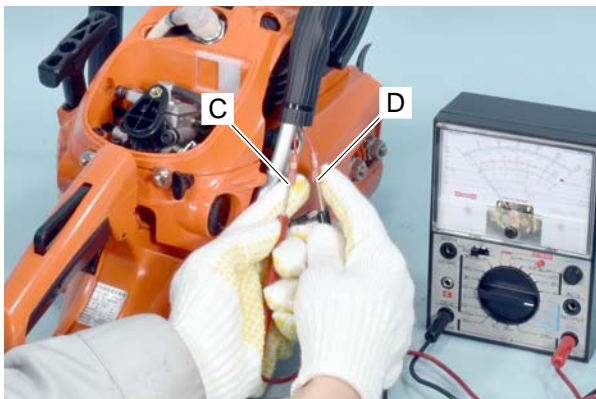
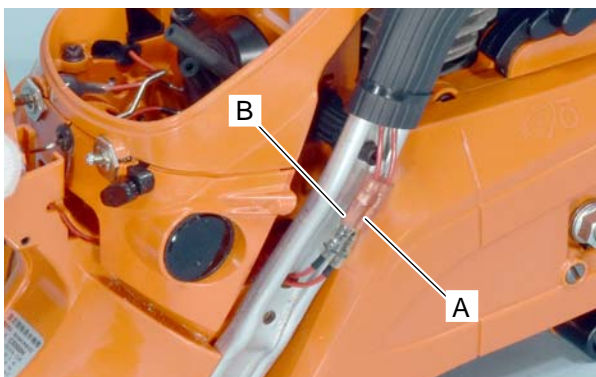
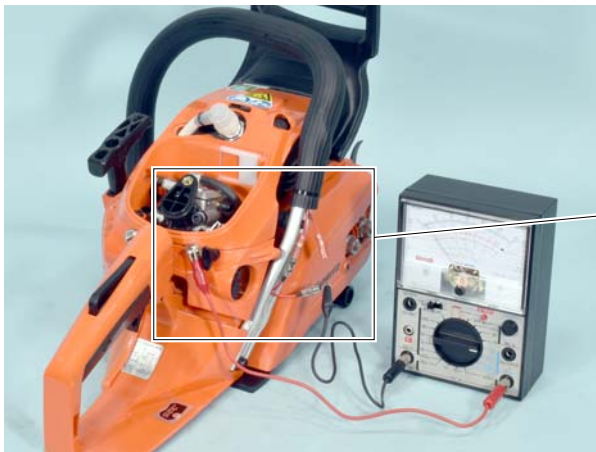
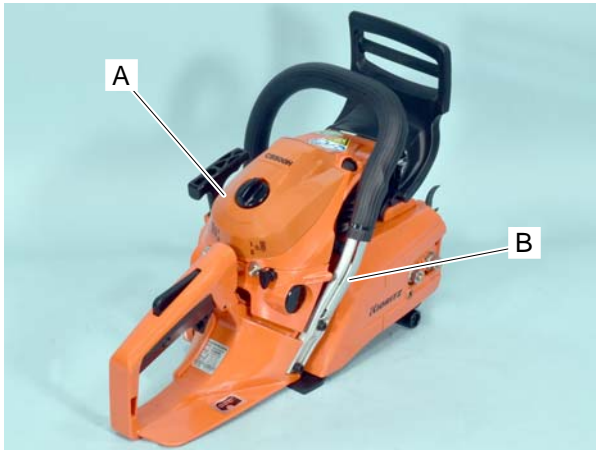
**Inspecting stator assembly**

1. Remove air cleaner cover (A), air filter and handle cover (B).

2. Disconnect stator lead coupler (C).

NOTE: If it is not clear which is stator lead coupler (C), remove carburetor and carburetor elbow, and check where the lead is connected to.

3. Connect one probe of ohm-meter or multi-meter to stator lead (D) as shown.

4. Connect the other probe to heater switch lever (E) or a clean ground as shown.

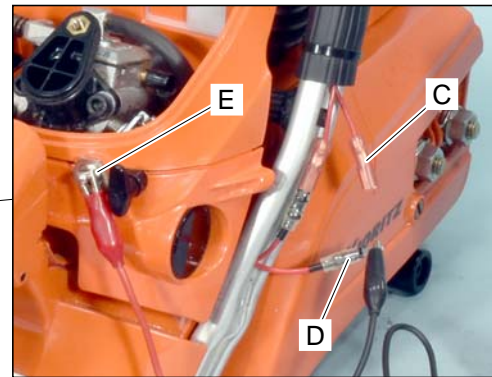

5. Tester should show that the circuit is in conducting state.

6. If stator assembly is defective, replace with a new one (Refer to 9-3-2 "Replacing stator assembly").

Inspecting front handle heater

1. Disconnect stator lead coupler (A) and rear handle heater coupler (B).

2. Connect one probe of ohm-meter or multi-meter to one lead of front handle heater (C) as shown.

3. Connect the other probe to other lead of front handle heater (D) as shown.

4. Tester should show that the circuit is in conducting state.

5. If front handle heater is defective, replace with a new one.

9-3-1 Inspecting heated handle (continued)

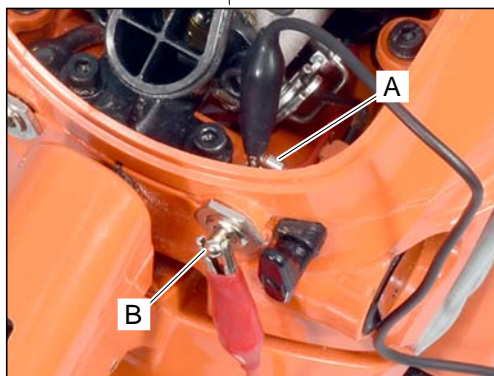
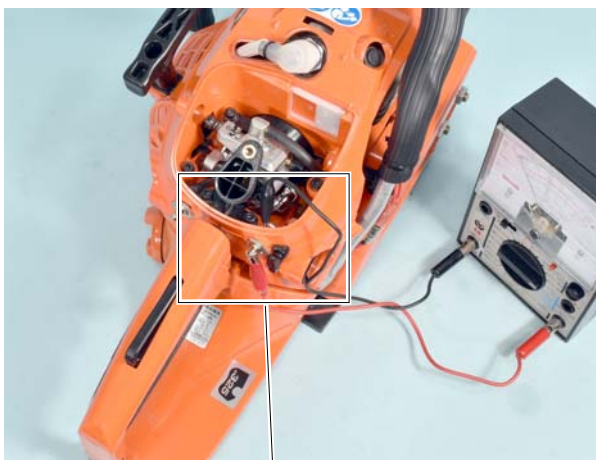
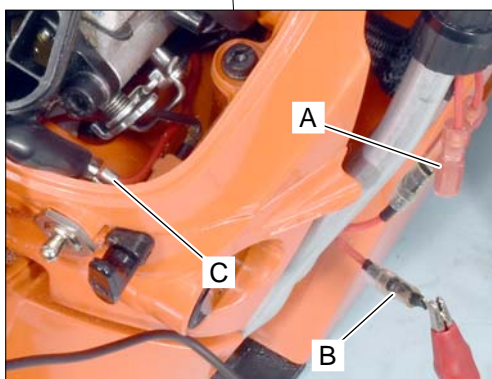
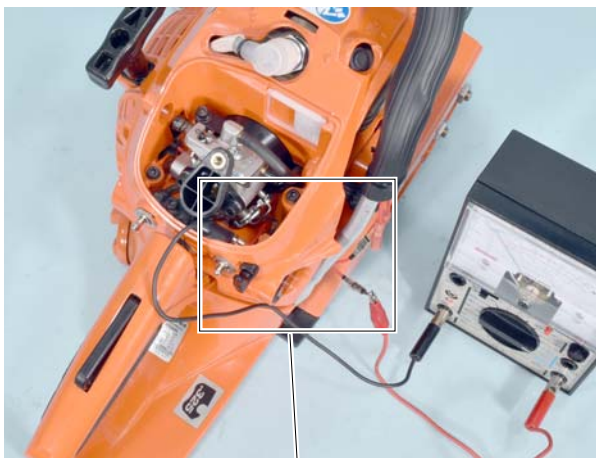

Inspecting rear handle heater

1. Disconnect rear handle heater lead coupler (A).

NOTE: If it is not clear which is rear handle heater lead coupler (A), remove carburetor and carburetor elbow, and check where the lead is connected to.

2. Connect one probe of ohm-meter or multi-meter to rear handle heater lead (B) as shown.
3. Connect the other probe to heater switch terminal (C) as shown.
4. Tester should show that the circuit is in conducting state.
5. If rear handle heater is defective, replace with a new one (Refer to 9-3-3 "Replacing rear handle heater").

Inspecting heater switch

1. Connect one probe of ohm-meter or multi-meter to heater switch terminal (A) as shown.
2. Connect the other probe to heater switch lever (B) as shown.
3. When heater switch is in "RUN" position, tester should show that the circuit is in conducting state.
4. When heater switch is in "STOP" position, tester should indicate infinite resistance.
5. If heater switch is defective, replace with a new one (Refer to 9-3-4 "Replacing heater switch").

9-3-2 Replacing stator assembly

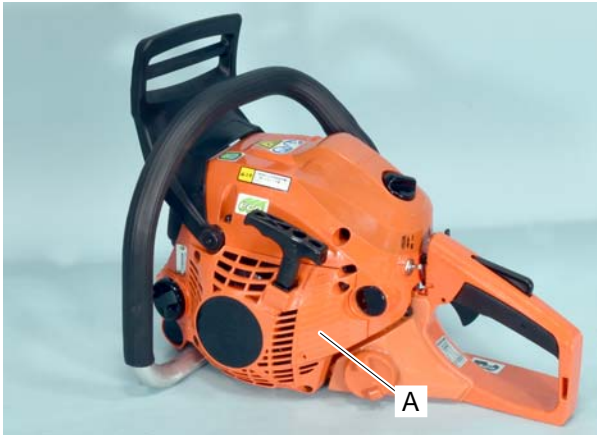

1. Remove air cleaner cover and handle cover.
2. Remove four bolts and remove starter assembly (A) from unit.

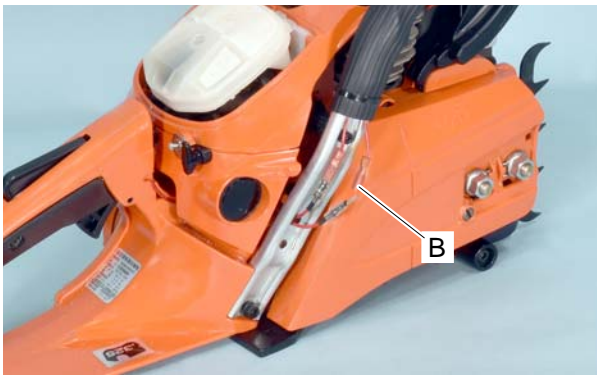

3. Disconnect stator lead coupler (B).

NOTE: If it is not clear which is stator lead coupler (B), remove carburetor and carburetor elbow, and check where the lead is connected to.

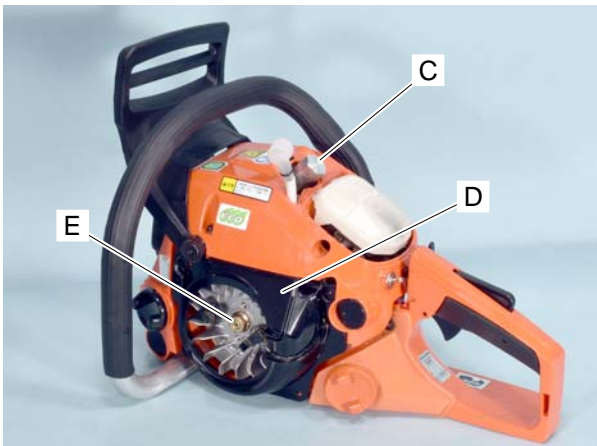

4. Install piston stopper X644-000020 (C) into spark plug hole by hand to stop crankshaft rotation.
5. Remove fan cover (D).
6. Remove nut (E) by rotating counterclockwise.

NOTE: Do not use power tool to remove nut (E). Otherwise, piston damage may occur.

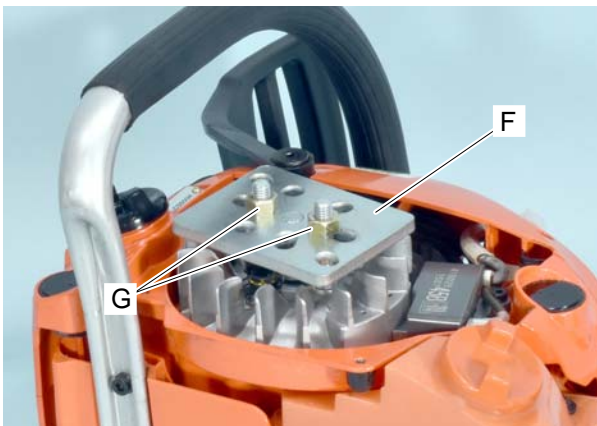

7. Set puller Y089-000111 (F) on flywheel as shown.
8. Tighten two nuts (G) on the puller alternately to remove flywheel.

9-3-2 Replacing stator assembly (continued)

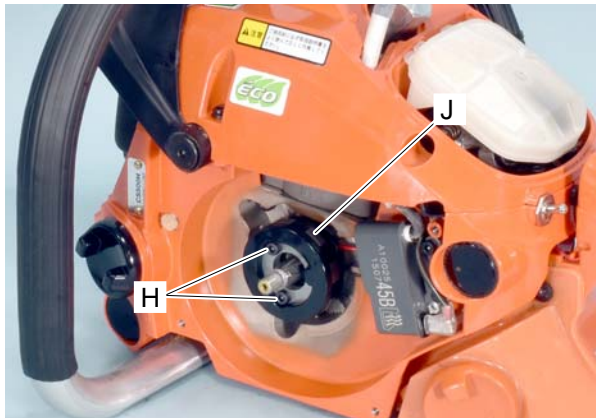

9. Remove two bolts (H) and remove stator assembly (J).

10. Install new stator assembly, and connect stator lead coupler (B).

11. Reinstall disassembled parts.

9-3-3 Replacing rear handle heater

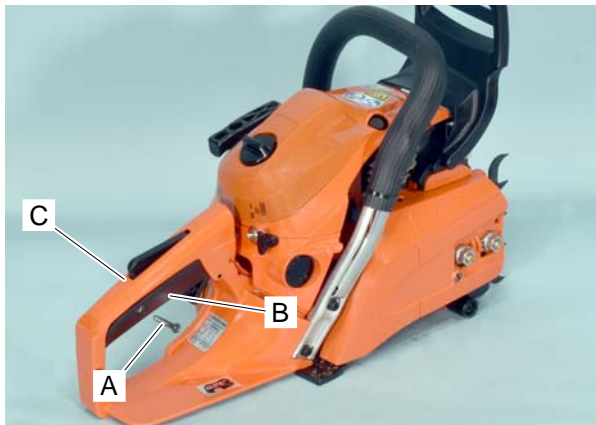

1. Remove air cleaner cover, air filter and handle cover.

2. Remove screw (A). Remove handle grip (B) and rear handle cover (C).

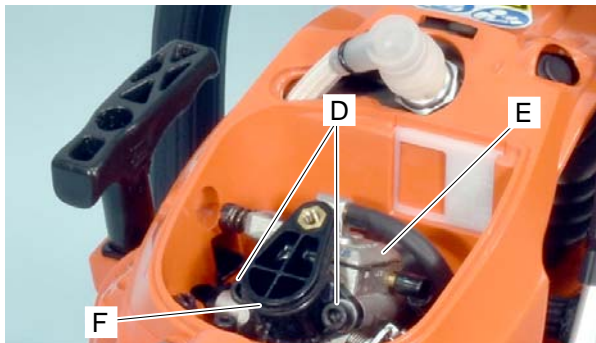

3. Remove two bolts (D) and remove carburetor (E) and carburetor elbow (F).

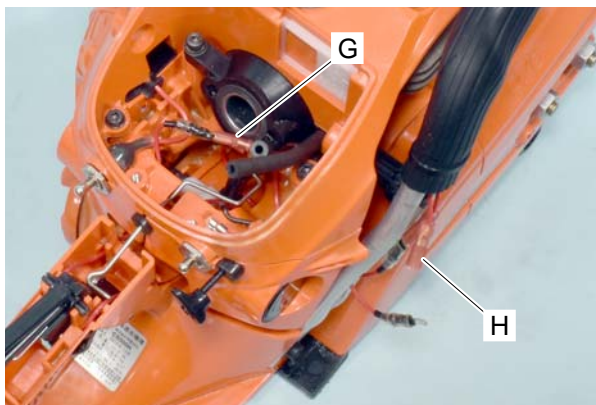

4. Disconnect heater switch coupler (G) and rear handle heater coupler (H).

9-3-3 Replacing rear handle heater (continued)

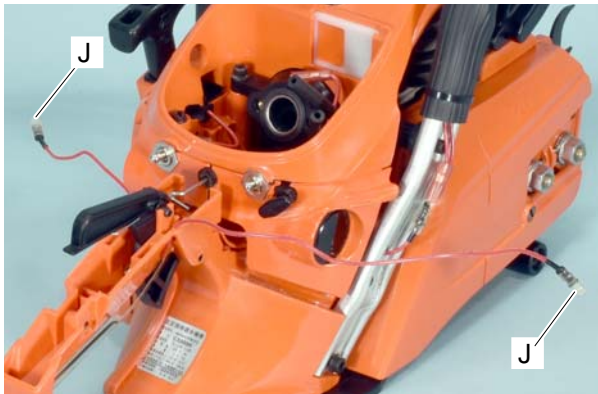

4. Remove boots (J) and + rear handle heater.

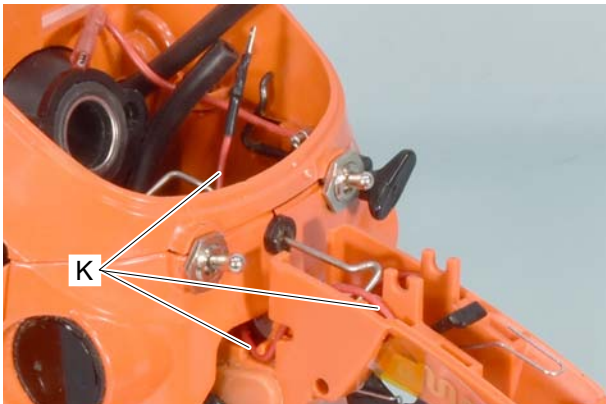

5. Install new rear handle heater.

6. Pass the rear handle heater lead (K) as shown.

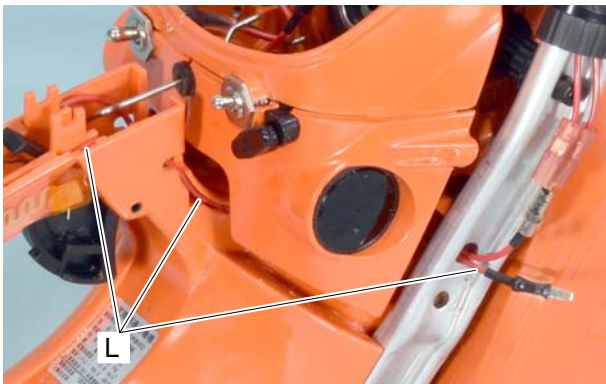

7. Pass the rear handle heater lead (L) as shown.

8. Reinstall boots (J) to each lead terminal as shown.

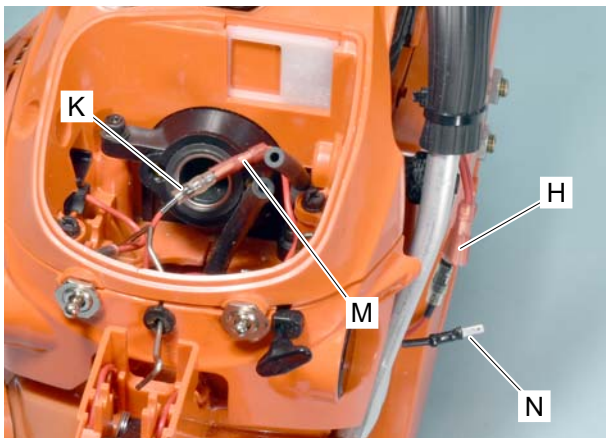
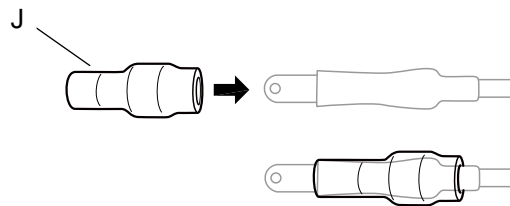

9. Connect rear handle heater lead (K) to heater switch lead (M) and rear handle heater lead (N) to coupler (H).

NOTE: Check if heater switch lead (M) is mounted without contacting with the side (P).

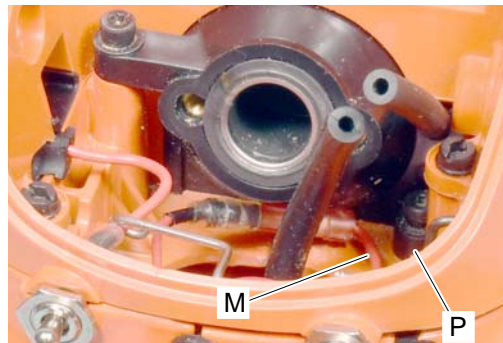

9-3-3 Replacing rear handle heater (continued)

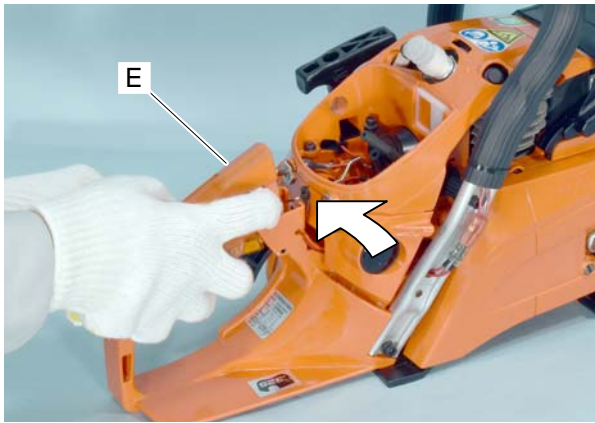

10. Insert the tab (e) of rear handle cover (E) into rear handle, and install rear handle cover (E) on rear handle, while pushing the rear handle cover (E) as shown.

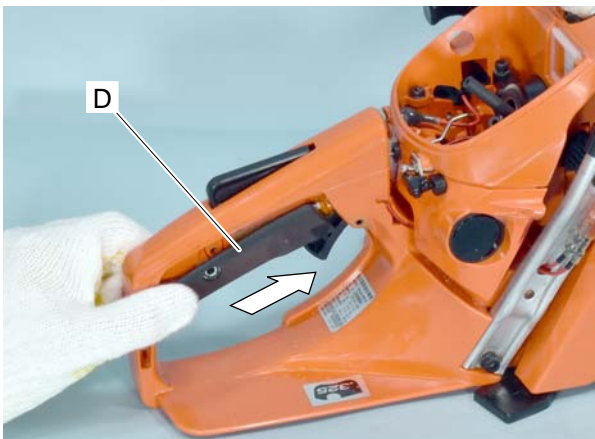
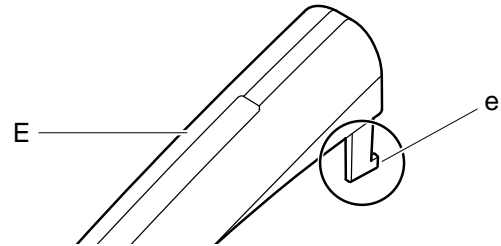

11. Insert the tab (d) of handle grip (D) into rear handle, and install handle grip (D) as shown.

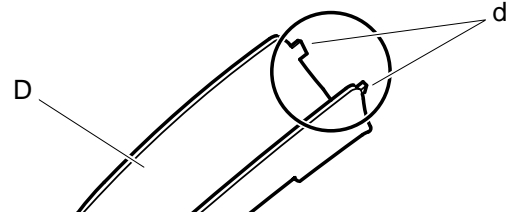

12. Reinstall disassembled parts.

9-3-4 Replacing heater switch

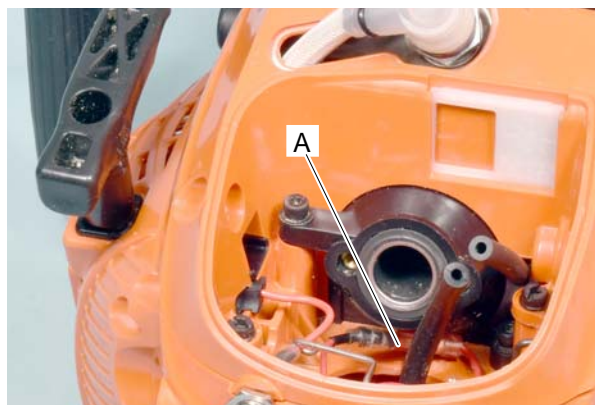

1. Remove air cleaner cover and air filter.
2. Remove carburetor and carburetor elbow.
3. Disconnect heater switch coupler (A) and remove heater switch.

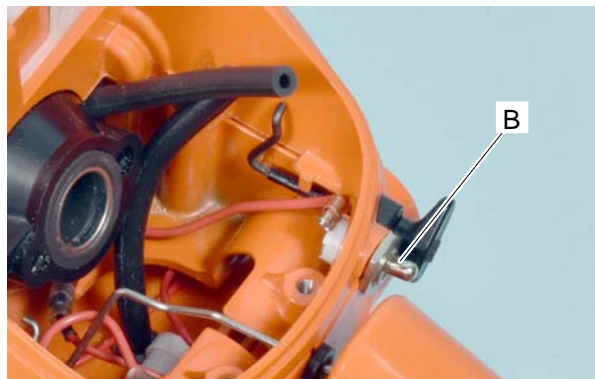

4. Install new heater switch (B) as shown.
5. Connect heater switch coupler (A).
6. Reinstall disassembled parts.

10 GUIDE BAR MOUNTING SYSTEM

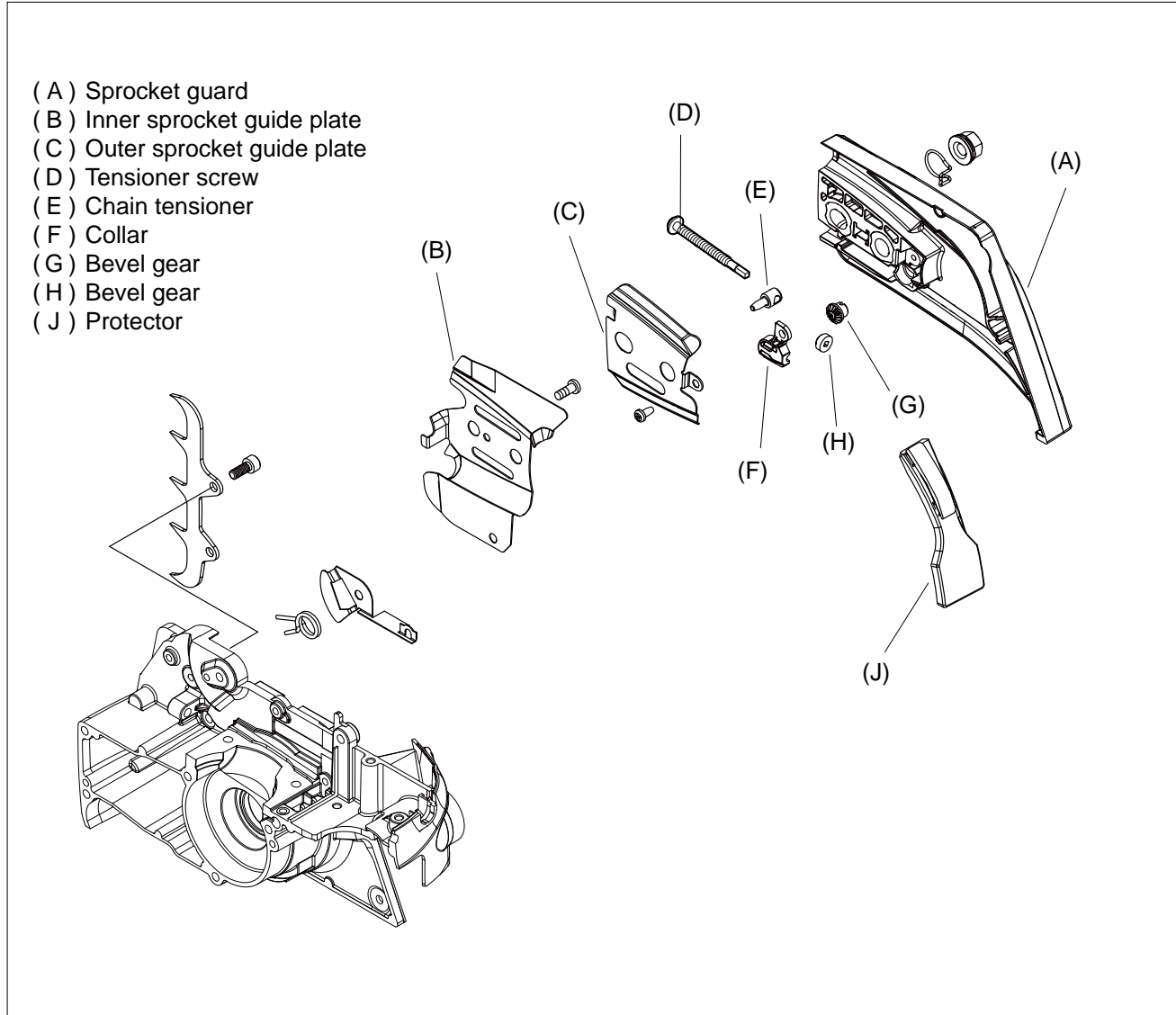

10-1 Replacing chain tensioner

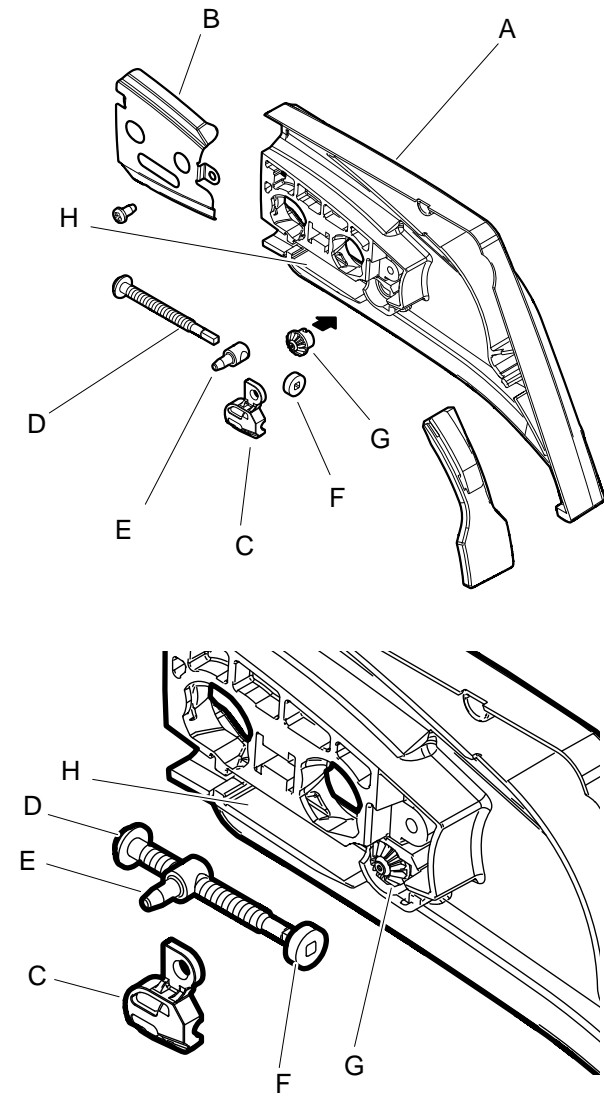

The diagram shows an exploded view of the chain tensioner assembly. Part A is the sprocket guard, B is the outer guide plate, C is the collar, D is the tensioner screw, E is the chain tensioner, F and G are bevel gears, and H is a slot in the sprocket guard. The top part of the diagram shows the disassembly process, and the bottom part shows the reassembly process.

1. Remove sprocket guard (A) from the unit.
2. Remove outer guide plate (B) and collar (C) from sprocket guard. Remove tensioner screw (D), chain tensioner (E) and bevel gears (F) (G).
3. Inspect them for damage or wear. Replace as required.
4. Install bevel gear (G) into sprocket guard.
5. Screw chain tensioner (E) on tensioner screw (D).
6. Insert bevel gear (F) in tensioner screw (D) with chain tensioner (E).
7. Install sub-assembled tensioner screw in slot (H) of sprocket guard, confirming engagement of bevel gear (F) and (G).
8. Reassemble outer guide plate (B) and collar (C).

10-2 Replacing guide bar stud

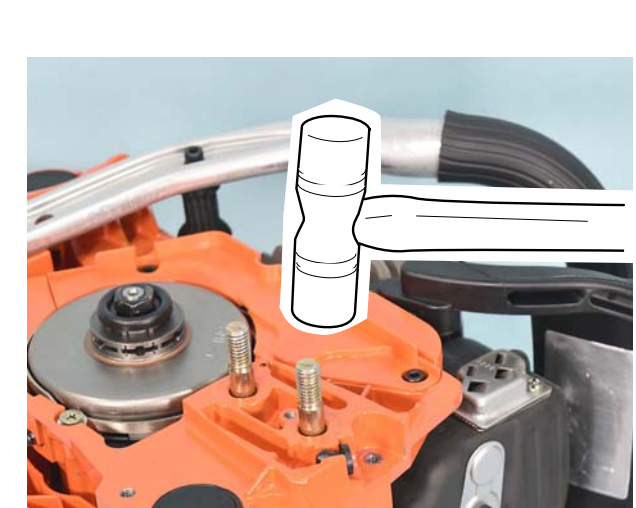

The photograph shows the guide bar stud being replaced. A hammer is used to tap the stud into the oil tank. The diagram shows the hammer tapping the stud into the oil tank.

1. Remove oil cap and empty oil from tank.
2. Tap guide bar stud lightly with copper hammer, and push into oil tank. Remove stud from oil tank.

10-3 Installing guide bar stud

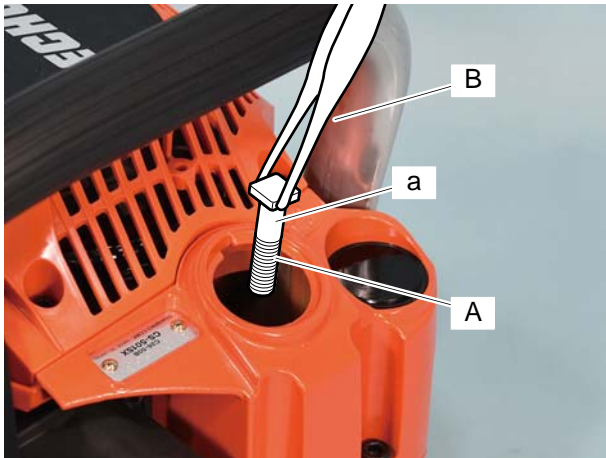

1. Apply adhesive (Loctite #609, ThreeBond 1373 or equivalent) to un-threaded part (a) of new guide bar stud (A).

2. Install new stud (A) to the stud-hole of oil tank using a pair of tweezers (B).

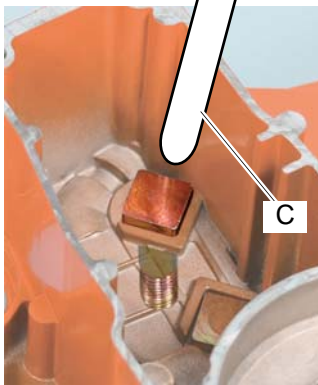

3. Lightly tap square head of stud with long bar tool (C) and hammer.

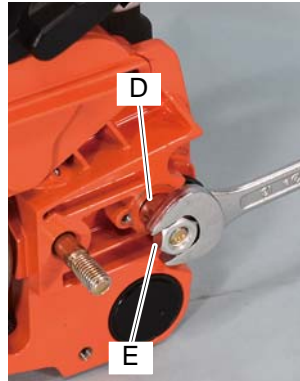
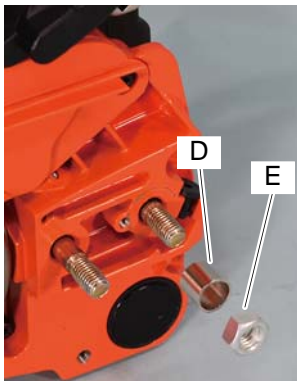

4. Install spacer [Bore: 8 to 10 mm (0.32 to 0.39 in), Height: 10 to 12 mm (0.39 to 0.47 in)] (D). Thread M8 nut (E) clockwise onto stud. Turn nut clockwise to pull stud through oil tank mounting hole. The square head of the stud should seat against the oil tank wall parallel with inner ribs.

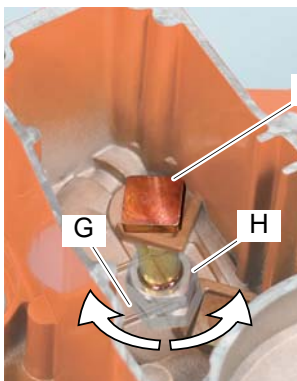

5. Look into oil tank and check if square head (F) of the stud is properly seated inside crankcase. If not, install two nuts to the stud and secure them against each other.



6. Turn nut (G) clockwise or nut (H) counterclockwise to correct the position of the square head.

7. Repeat step 4 to seat the stud correctly in square hollow inside oil tank.

8. Install all removed parts.

11 MAINTENANCE GUIDE

11-1 Disassembly chart

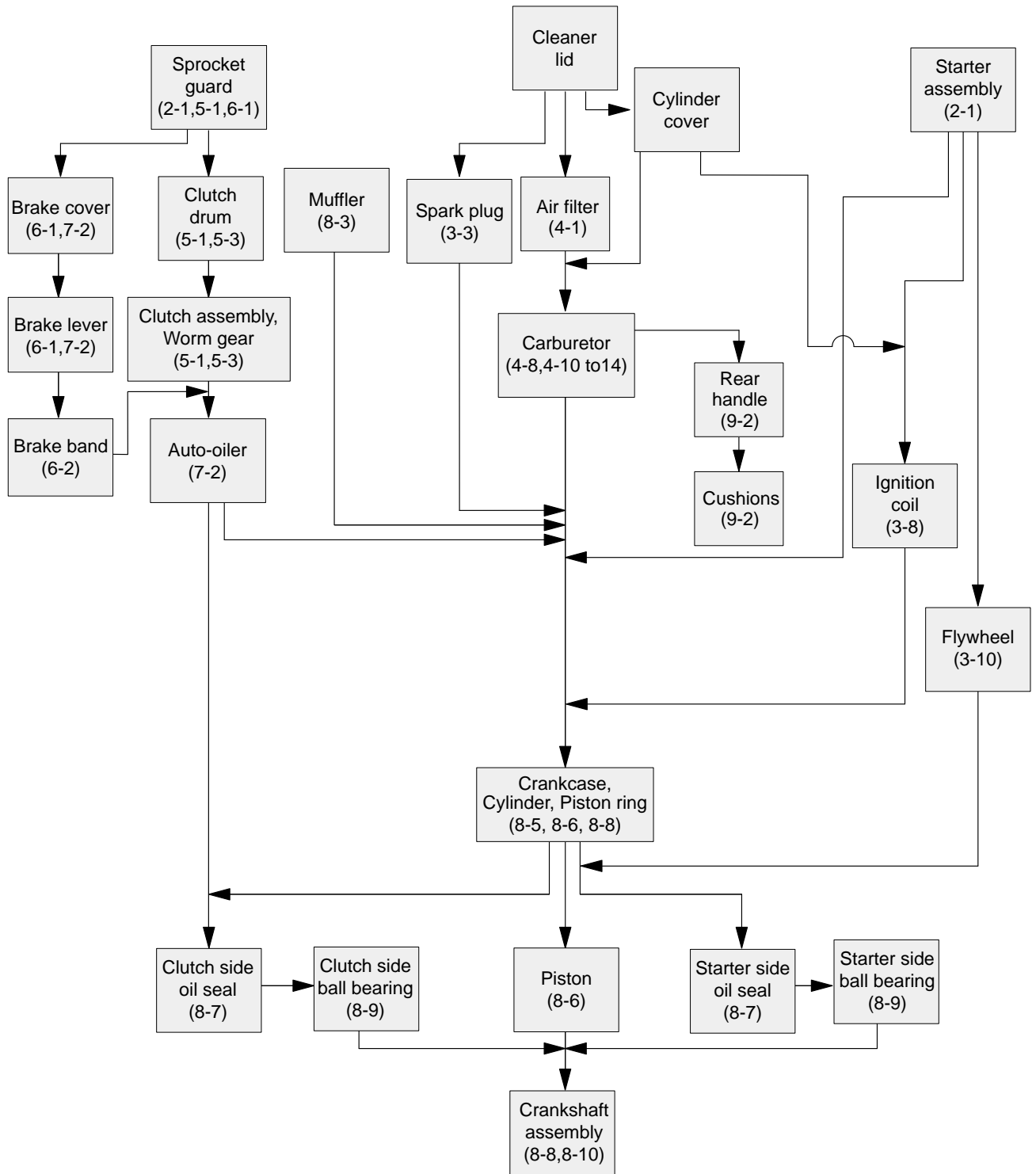

11-2 Troubleshooting guide

TROUBLE	
Engine does not crank.	01
Engine does not start.	02
Fuel leaks.	03
Idling is not stable.	04
Acceleration is poor.	05
Engine stalls at high speed.	06
Engine lacks power.	07
Engine seizure / overheat	08
Engine misfires.	09
Engine/others are extremely noisy.	10
Fuel consumption is excessive.	11
Vibration is excessive.	12
Engine does not stop.	13
Oiler does not function.	14
Saw chain does not cut well.	15

INSPECTING	REFERENCES	Inspecting <input checked="" type="radio"/> first.														
		15	14	13	12	11	10	09	08	07	06	05	04	03	02	01
Starter system																
Starter pawl/spring	2-4															<input checked="" type="radio"/>
Starter drum/rope	2-2															<input type="radio"/>
Rewind spring	2-3															<input type="radio"/>
Ignition system																
Sparks	3-2							<input checked="" type="radio"/>			<input type="radio"/>	<input type="radio"/>	<input type="radio"/>			<input checked="" type="radio"/>
Spark plug	3-3							<input type="radio"/>	<input type="radio"/>		<input type="radio"/>	<input type="radio"/>	<input type="radio"/>			<input type="radio"/>
Spark plug cap / coil	3-7							<input type="radio"/>								<input type="radio"/>
Ignition switch	3-4			<input checked="" type="radio"/>				<input type="radio"/>								<input type="radio"/>
Ignition coil	3-6, 3-8							<input type="radio"/>			<input type="radio"/>	<input type="radio"/>	<input type="radio"/>			<input type="radio"/>
Pole shoe air gaps	3-9							<input type="radio"/>	<input type="radio"/>				<input type="radio"/>			<input type="radio"/>
Flywheel	3-10				<input type="radio"/>			<input type="radio"/>					<input type="radio"/>			<input type="radio"/>
Flywheel key	3-10							<input type="radio"/>	<input type="radio"/>	<input type="radio"/>		<input type="radio"/>	<input type="radio"/>			<input type="radio"/>
Clutch system																
Clutch shoes/spring/bearing	5-1 to 5-3	<input type="radio"/>			<input type="radio"/>		<input type="radio"/>									
Clutch drum	5-1, 5-3	<input type="radio"/>			<input type="radio"/>		<input type="radio"/>									
Sprocket	1-5, 5-1	<input type="radio"/>			<input type="radio"/>											

(Continued)

11-3 Service Intervals

Inspecting point	Service	Reference	Intervals	
			Before use	3 months or 100 hour
Screws and bolts *	Retighten / Replace		○	
Air filter	Inspect / Replace / Clean	4-1	○	
Choke system	Inspect / Replace		○	
Carburetor	Inspect / Repair	4-8 to 4-14		○
Fuel leaks	Inspect / Repair	4-2, 4-3	○ **	
Fuel line	Inspect / Repair	4-3, 4-5-1	○	
Cooling system	Inspect / Clean	8-2	○	
Spark plug	Inspect / Replace	3-3		○
Fuel strainer	Clean / Replace	4-2		○
Leads and connections	Inspect / Repair	3-5		○
Fuel tank	Clean inside.	4-3		○
Muffler and exhaust port	Clean	8-3		○
Starter system	Inspect / Repair	2-1 to 2-4	○	
Oil tank	Clean inside.			○
Oil strainer	Clean / Replace	7-1		○
Sprocket	Inspect / Replace	1-5, 5-1		○
Guide bar	Inspect / Clean		○	
Chain brake	Inspect / Repair	6-1, 6-2	○	

IMPORTANT: Service intervals shown above are maximum. Actual use and your experience will determine the frequency of required maintenance.

* Retighten the following screws and bolts after first 1 week use, and every 3 months.

Cylinder cover screws (3 pcs.)

Starter assembly screws (4 pcs.)

Cushion bolts (4 pcs.)

Front handle screws (5 pcs.)

Muffler bolts (4 pcs.)

** Inspect after every refuel.

ECHO[®]

shindaiwa[®]

YAMABIKO

Published by
YAMABIKO Corp.
Tokyo Japan

1902