

TECHNICAL INFORMATION

SUBJECT: Control cable assembly and Handle grip on
ECHO PB-580 and shindaiwa EB600RT

Number: Y2017-634 (1/3)

Issued: Sep. 29, 2017

Revised: Feb. 28, 2019

To prevent accumulation of static electricity on the unit, changed handle grip rubber to conductive elastomer and added discharge clip on switch lead.

PB-580(37)	Serial Number 37004004* to 37004508	Serial Number 37004509 and after
EB600RT(37)	Serial Number 37001211 and before	Serial Number 37001212 and after

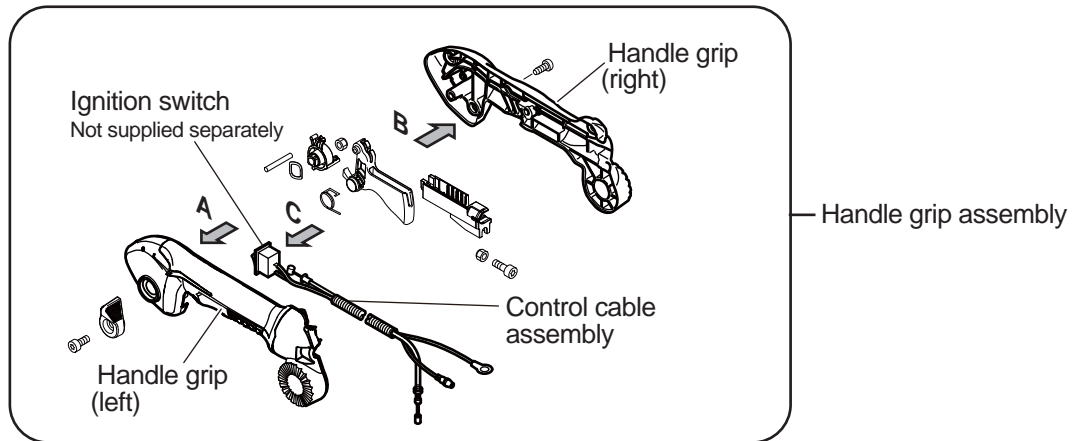

Handle grip assembly

Handle grip (left)

Handle grip (right)

P021-051890 : PB-590
P021-051990** : EB600RT

C400-001530 or C400-001531

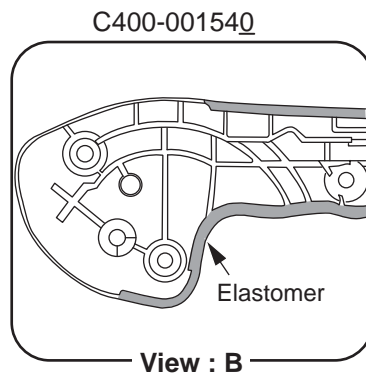
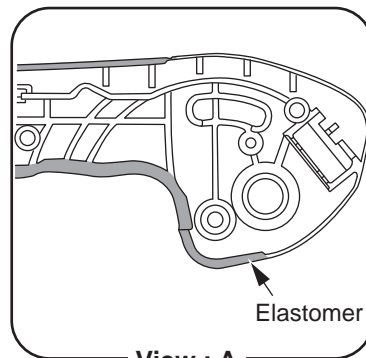

P021-052250 : PB-590
P021-052230 : EB600RT

C400-001532

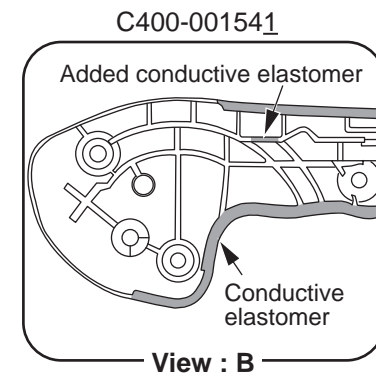
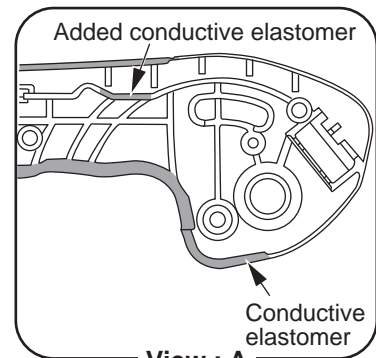

* Refer to Technical Information No.Y2016-611 before this serial number.

** Handle grip assembly P021-051990 does not include control cable assembly.

(Continued)

TECHNICAL INFORMATION Number: Y2017-634 (2/3)

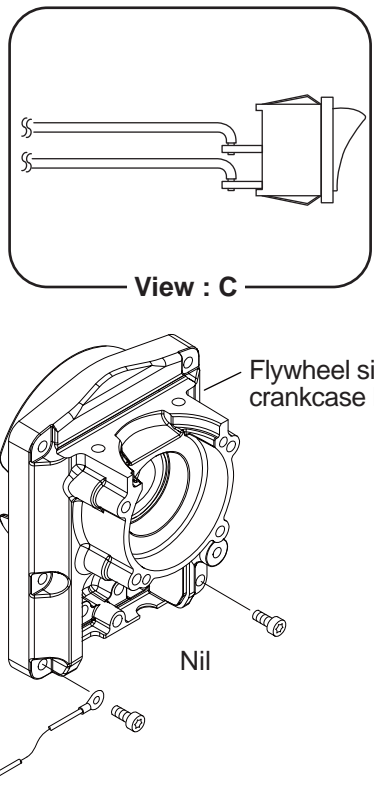
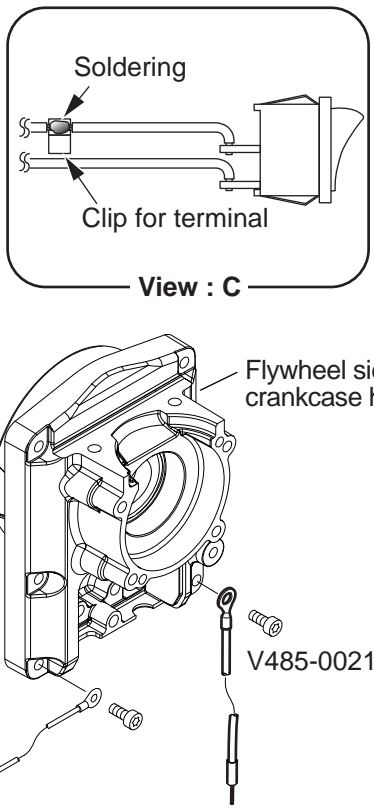
<p>Control cable assembly</p> <p>Lead</p>	<p>V043-001120</p>  <p>View : C</p> <p>Flywheel side crankcase half</p> <p>Nil</p>	<p>V043-001180 or V043-001190</p>  <p>Soldering</p> <p>Clip for terminal</p> <p>View : C</p> <p>Flywheel side crankcase half</p> <p>V485-002181</p>
<p>Handle grip assembly P021-051890 and P021-051990 can be replaced with P021-052250 and P021-052230 respectively.</p> <p>Handle grip (left) C400-001530 and C400-001531 can be replaced with C400-001532. Handle grip (left) C400-001532 has been already installed on some units before these serial numbers.</p> <p>Handle grip (right) C400-001540 can be replaced with C400-001541. Handle grip (right) C400-001541 has been already installed on some units before these serial numbers.</p> <p>Control cable assembly V043-001120 and V043-001180 can be replaced with V043-001190.</p> <p>Lead V485-002181 can be used on the unit before this change.</p>		
<p>See the next page for details on new parts installation.</p>		

Clip on control cable assembly V043-001180 or V043-001190 installation

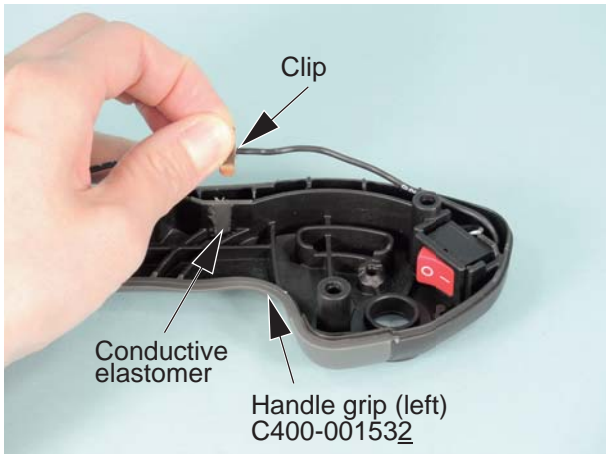

Install clip on control cable assembly V043-001180 or V043-001190 to the rib made of conductive elastomer.

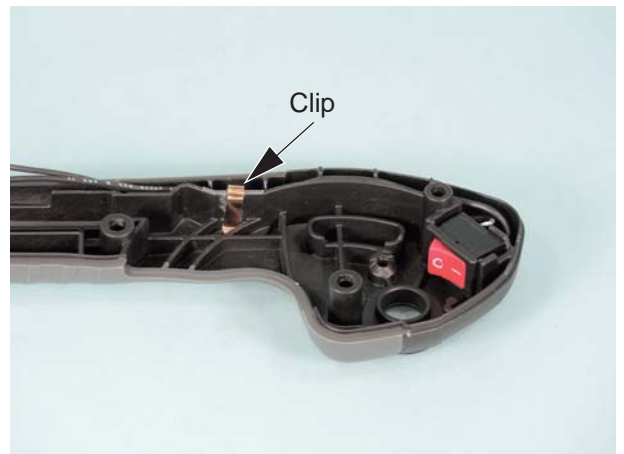

After the installation

Lead V485-002181 installation

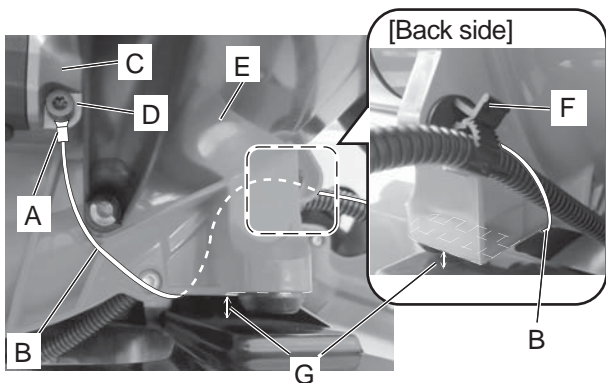

1. Install terminal (A) of lead V485-002181(B) to flywheel side crankcase half (C) and tighten bolt (D).
2. Route the lead (B) below fan case (E) as shown and clip the lead (B) into throttle cable retaining clip (F).

NOTE : Don't pass the lead (B) to gap (G).

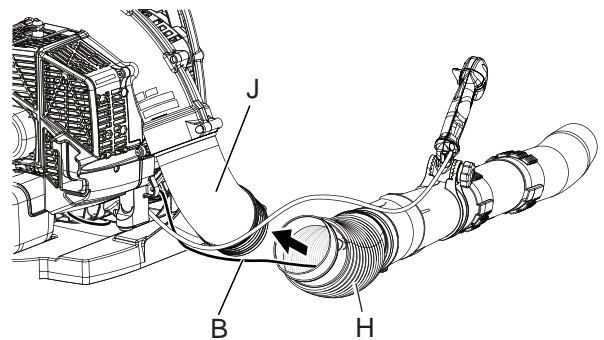

3. Install the lead (B) through flexible pipe (H). Leave enough slack in the lead (B) to allow for full rotation of elbow (J).
4. Assemble flexible pipe (H) to elbow (J) on blower.