



Parts Manual

Mfg. No: 1695329
L1428EX, 28" 13.5GT Two Stage Large

Model Components	Page
Auger Drive Group.....	4
Auger Housing & Chute Group.....	6
Decals Group.....	10
Engine Group.....	12
Handle & Controls Group.....	16
Traction Drive Group - EZ Turn - 28" Model.....	20
Wheel & Tire Group.....	22
Torque Specification Chart.....	24

Not For
Reproduction

Auger Drive Group

Note: Unless noted otherwise, use the standard torque specifications

Mfg. No: 1695329

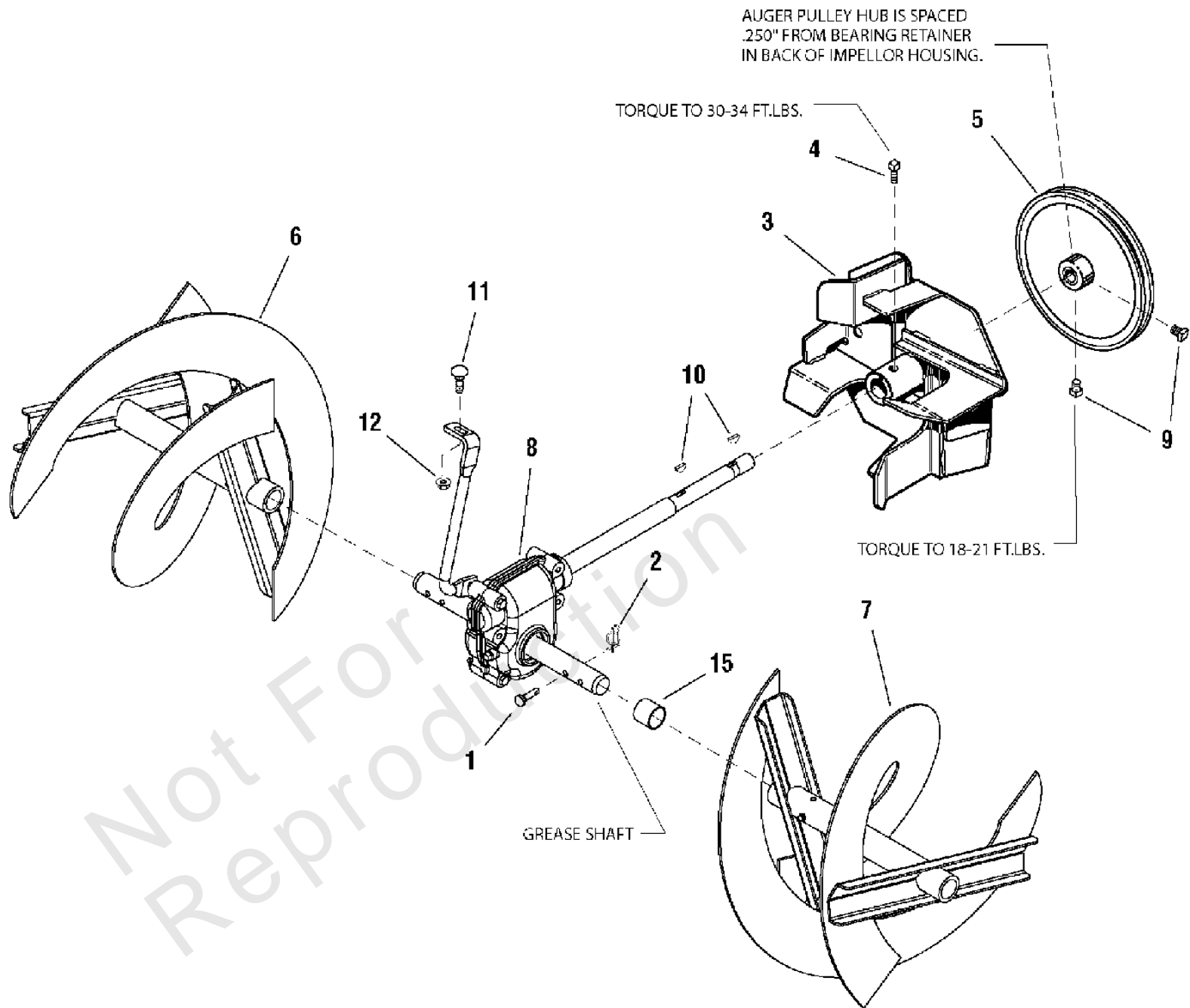

Auger Drive Group

REF NO	PART NO	QTY	DESCRIPTION
1	1668344	2	PIN, SHEAR
2	7023590	2	COTTER PIN, 1/4" Self Locking
3	1612187A	1	IMPELLER ASSEMBLY, Large Frame Snow
4	1960474	1	SCREW, Set, Square Head Cup Point 3/8-16 x 1/2 G8
5	1732185	1	PULLEY, w/Hub
6	1734674A	1	AUGER ASSEMBLY, 24" & 26" R.H.
6	1734676A	1	AUGER ASSEMBLY, 28" & 30" R.H.
6	1734678A	1	AUGER ASSEMBLY, 32" R.H.
7	1734673A	1	AUGER ASSEMBLY, 24" & 26" L.H.
7	1734675A	1	AUGER ASSEMBLY, 24" & 30" L.H.
7	1734677A	1	AUGER ASSEMBLY, 32" L.H.
8	1732303	1	GEAR BOX ASSEMBLY
9	1928721	2	SCREW, Set, Square Head Cup Point 5/16-18 x 1/2 G8
10	2818312	2	KEY, Woodruff
11	1931333	1	CARRIAGE BOLT, 5/16-18 x 3/4 G5
12	1931277	1	NUT, Hex Flange Whiz Lock, 5/16-18HEX FLANGE 5/16-18
15	1733406	2	TUBE

Not For
Reproduction

Auger Housing & Chute Group

Note: Unless noted otherwise, use the standard torque specifications

Mfg. No: 1695329

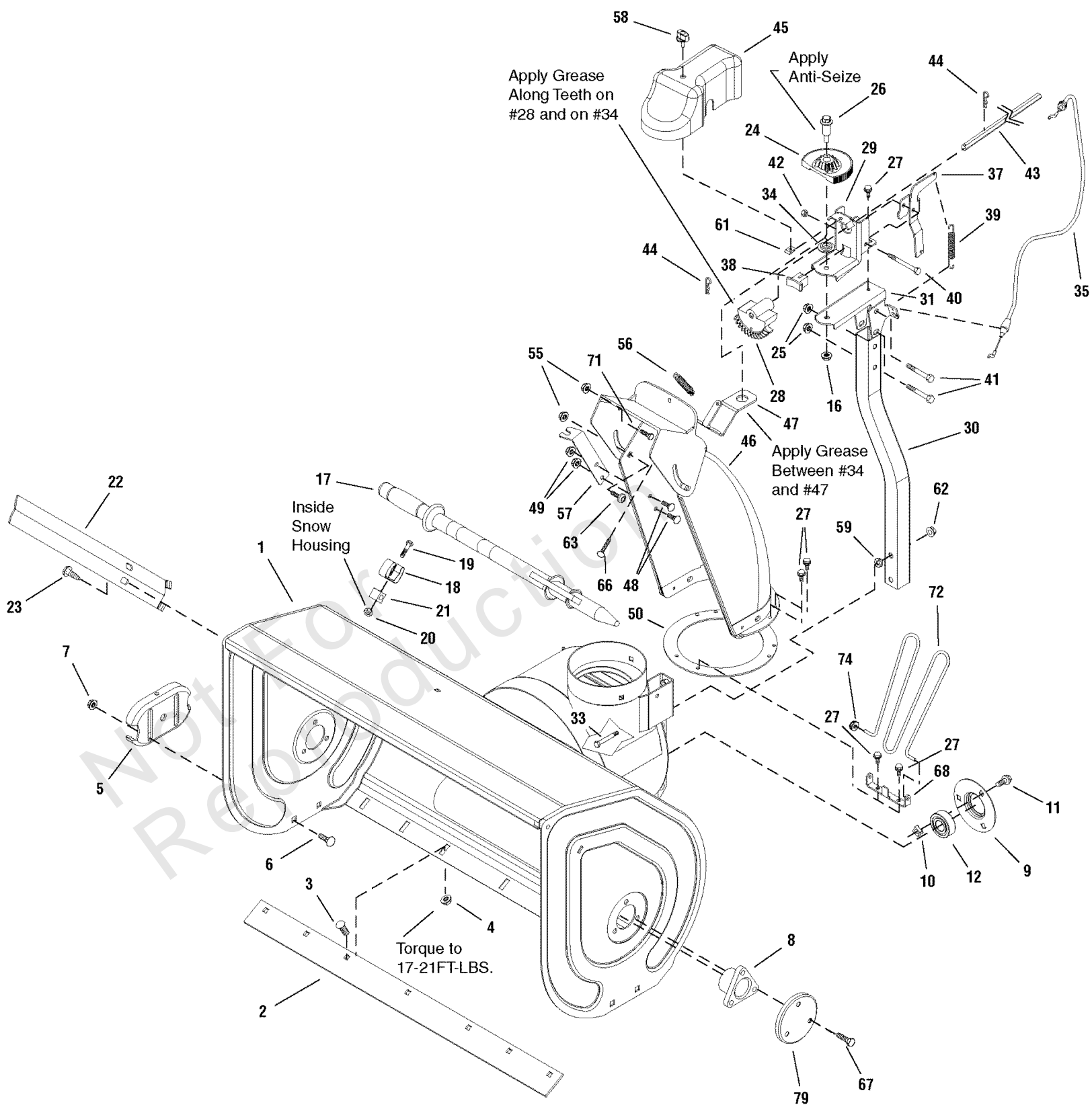

Auger Housing & Chute Group

REF NO	PART NO	QTY	DESCRIPTION
1	1734555D	1	HOUSING ASSEMBLY, 26"
1	1734556D	1	HOUSING ASSEMBLY, 28"
1	1734557D	1	HOUSING ASSEMBLY, 30"
1	1734558D	1	HOUSING ASSEMBLY, 32"
2	1732384A	1	BLADE, Scraper 26"
2	1709947A	1	BLADE, Scraper 28"
2	1732385A	1	BLADE, Scraper 30"
2	1709948A	1	BLADE, Scraper 32"
3	1960699	5/7	CARRIAGE BOLT, 5/16-18 x 5/8 G5 -(Quantity 7 used on 30" & 32" Models)
4	1935048	5/7	NUT, Hex Flange 5/16-18 Two-Way Lock
5	1727854A	2	SKID, Shoe Reversible
6	1960711	4	CARRIAGE BOLT, 3/8-16 x 3/4 G5
7	1960687	4	NUT, Hex Flange 3/8-16 ESNA
8	-----	2	BEARING, Flange
9	-----	1	BEARING, Retainer
10	1930659	3	RETAINER, Nut, 5/16-18
11	1960738	3	SCREW, Hex Whiz Lock Flange 5/16-18 x 3/4
12	-----	1	BEARING
16	1931277	7	NUT, Hex Flange 5/16-18, Whiz Lock
17	1733209	1	STICK, Cleanout w/Brush
18	722242	2	CLIP, Retainer
19	2860604	2	CAPSCREW, Hex Washer, #10 x 1-1/4
20	1933896	2	NUT, Hex Lock 10-24 w/Nylon Insert
21	724565	2	BLOCK, Universal Pivot
22	1733102A	2	CUTTER, Drift w/Tabs
22	1733102C	2	CUTTER, Drift w/Tabs
23	1664847	2	SCREW, Hex Washer Head Taptite 5/16-18 x 3/4
24	1732608	1	GEAR, 13 Tooth
25	1960684	2	NUT, Hex Keps Conical Washer, 5/16-18
26	1732412	1	BOLT, Shoulder 5/16-18 x 3/5
27	1925003	6/8	SCREW, Hex Washer Head Taptite 1/4-20 x 1/2 -(Quantity 8 used only on CE/Export Models)
28	1732607	1	GEAR, Sector 34 Tooth Powdered Metal
29	1732602A	1	SUPPORT, Driver Gear
30	1734414A	1	TUBE
31	1732606A	1	BRACKET, Gear Support
33	1931353	2	CARRIAGE BOLT, 3/8-16 x 1-3/4
34	1733026	1	WASHER, Powdered Metal
35	1732238	1	CABLE, Chute Brake
37	1732837A	1	BRACKET, Brake
38	1732308	1	ARM & PAD ASSEMBLY, Brake
39	1679554	1	SPRING, Extension
40	1923282	1	CAPSCREW, Hex Head 1/4-20 x 2-1/2 G5
41	1922127	2	CAPSCREW, Hex Head 5/16-18 x 1-3/4
42	1923358	1	NUT, Hex Centerlock 1/4-20
43	1732231	1	ROD, Hex Chute
44	1722460	2	PIN, Quick
45	1732241	1	COVER, Chute
46	1732506	1	CHUTE & DEFLECTOR ASSEMBLY
47	1732028	1	BRACKET, Chute Support
48	1960252	2	CARRIAGE BOLT, 1/4-20 x 5/8 G5

Auger Housing & Chute Group

Note: Unless noted otherwise, use the standard torque specifications

Mfg. No: 1695329

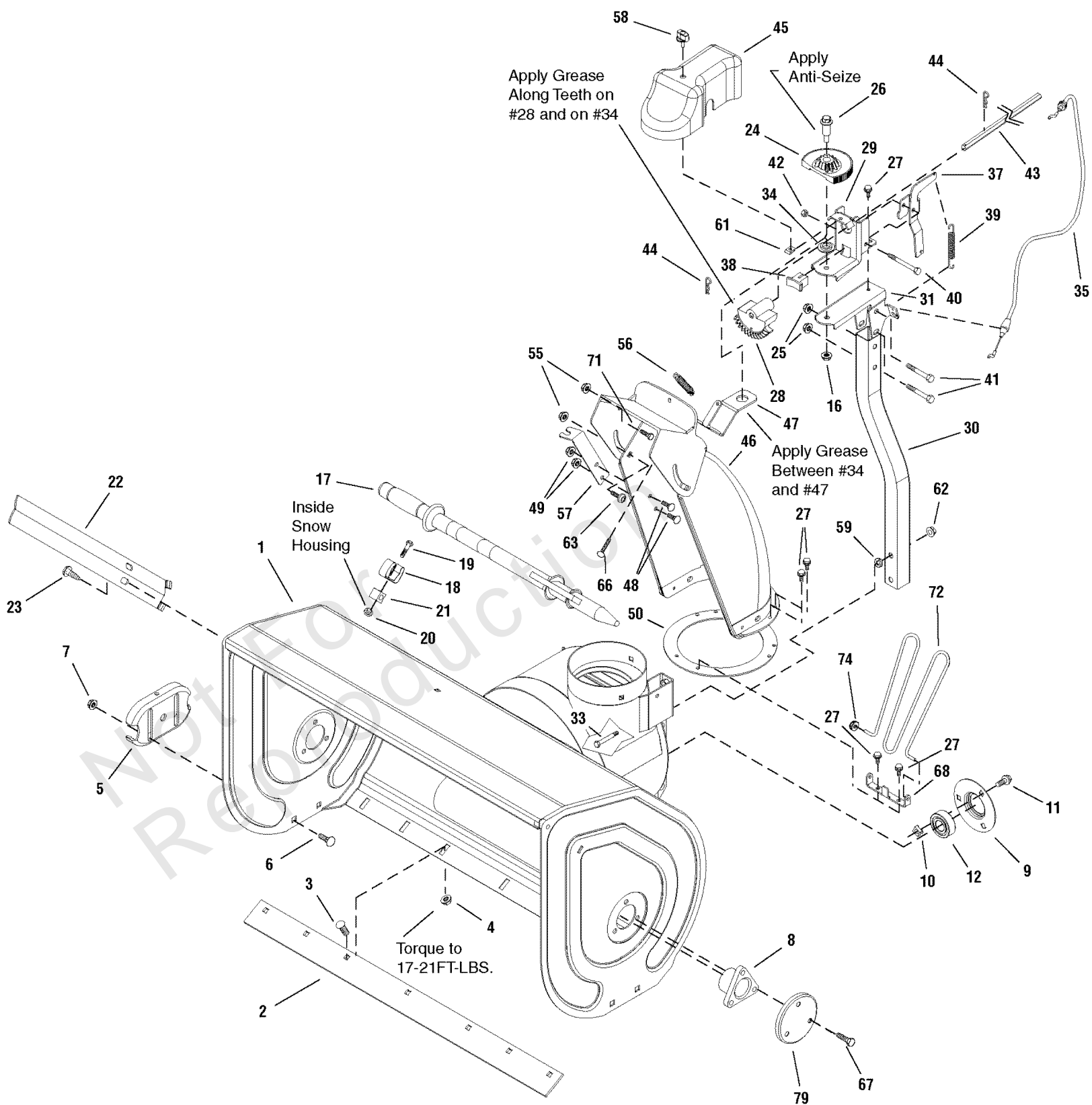

Auger Housing & Chute Group

REF NO	PART NO	QTY	DESCRIPTION
49	1960294	2	NUT, Hex Flange 1/4-20 Whiz Lock
50	1732172A	1	RING, Chute Base
55	1960686	3	NUT, Hex Flange 5/16-18 ESNA
56	1733455	1	SPRING, Extension
57	1733082A	1	BRACKET, Cable
58	696239	1	KNOB & SCREW ASSEMBLY
59	1731942	2	NUT, Push Pal 3/8
61	1960593	1	NUT, Retainer Speed #10-24 w/Extrusion
62	1960680	2	NUT, Hex Keps Conical Washer 3/8-16
63	1960756	2	SCREW, Truss Head Trox Drive 5/16-18 x 3/4
66	7091542	3	SCREW, Pan Head Self Tap Torx 5/16-18 x 1/2
67	1931202	6	SCREW, Hex Washer head Taptite 5/16-18 x 1-1/4
68	1733476A	1	BRACKET, Chute Guard -(CE/Export)
71	1960086	1	SCREW, Truss Head Torx 5/16-18 x 7/8
72	1733475	1	GUARD, Chute -(CE/Export)
74	1960140	2	NUT, Push -(CE/Export)
79	-----		COVER, Bushing

Not For
Reproduction

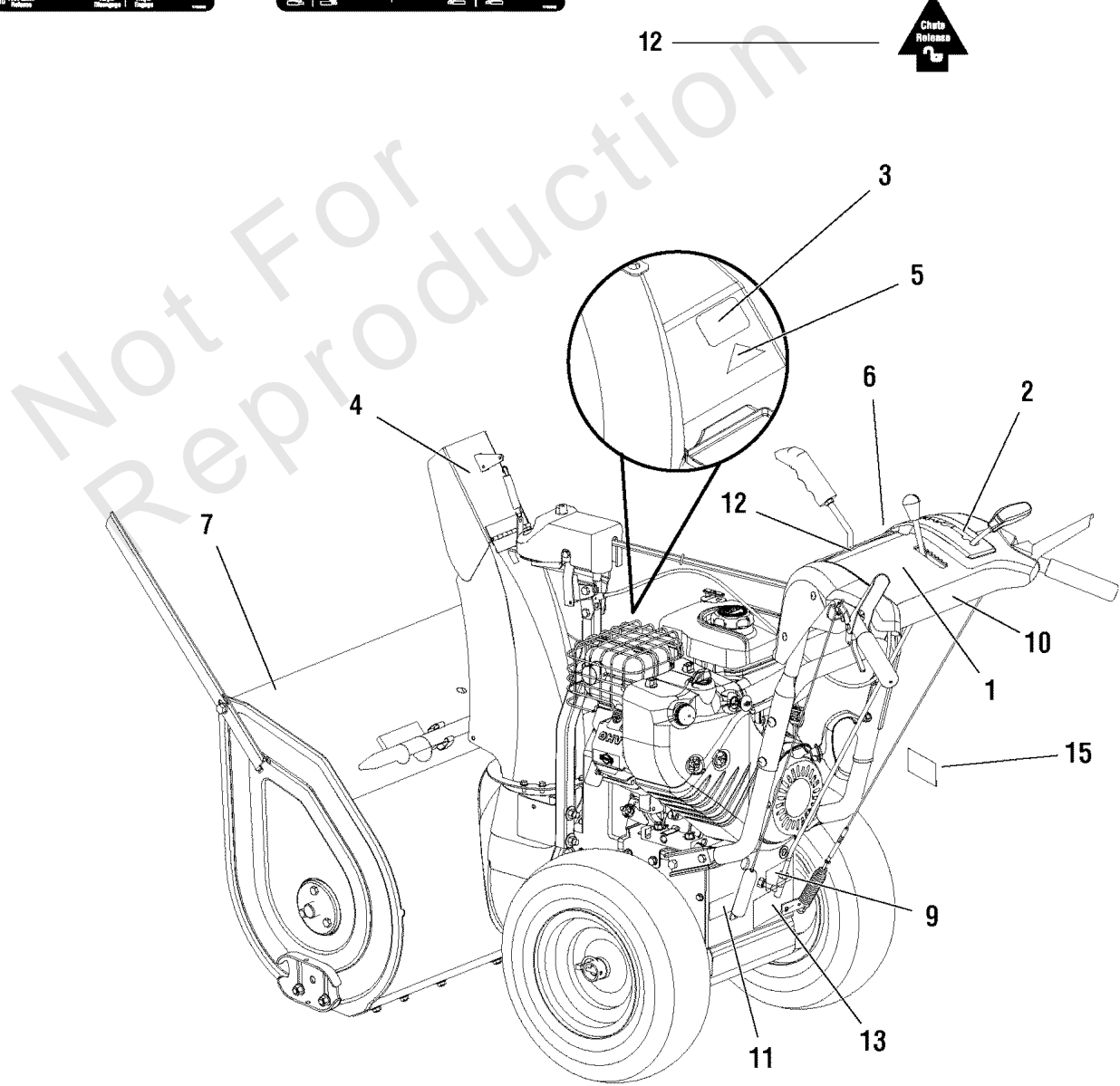
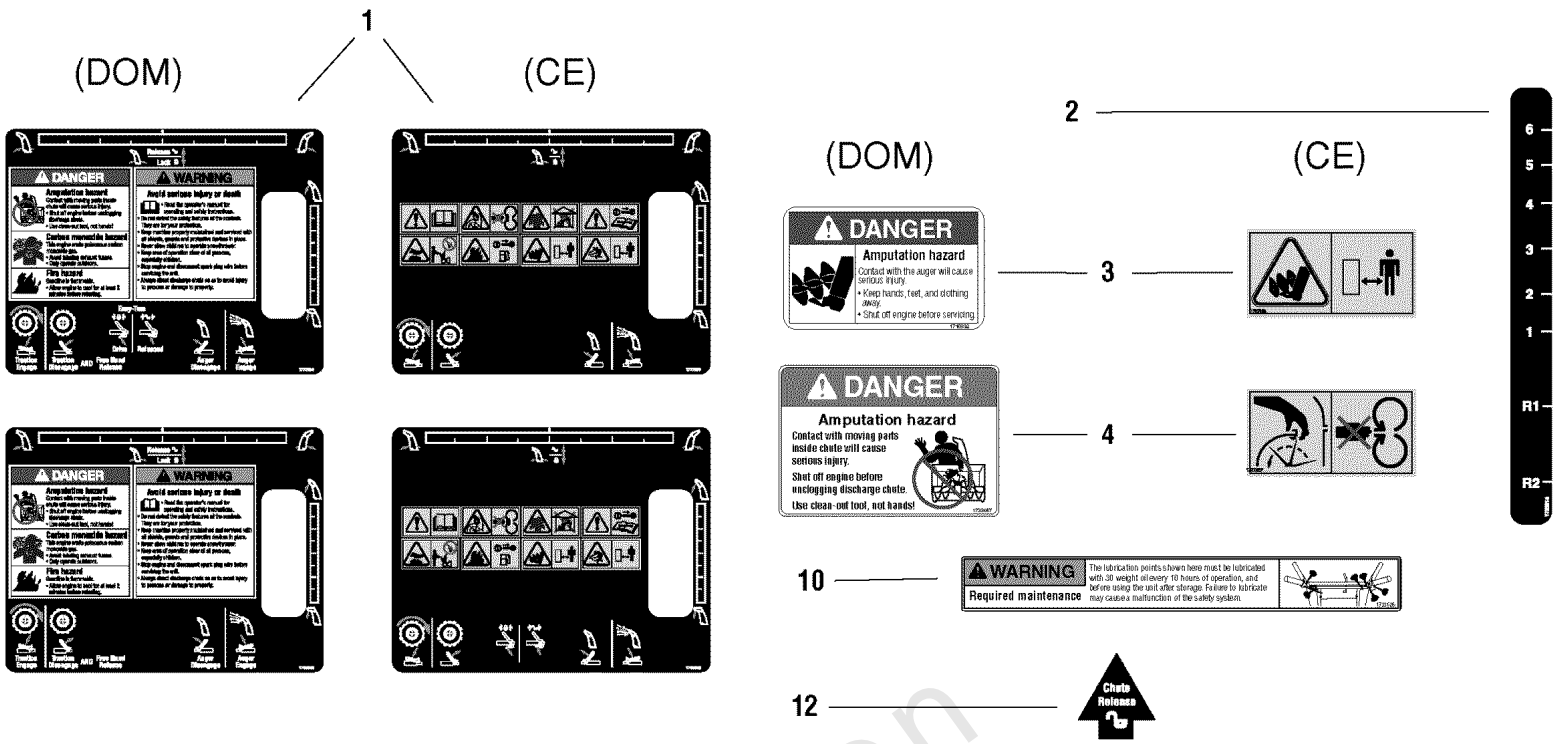

Decals Group

REF NO	PART NO	QTY	DESCRIPTION
1	1733056	1	DECAL, Dashboard Standard Drive -(Domestic Only)
1	1733033	1	DECAL, Dashboard EZ Turn -(Domestic Only)
1	1733059	1	DECAL, Dashboard Standard Drive -(CE/Export Only)
1	1733060	1	DECAL, Dashboard EZ Turn -(CE/Export Only)
2	1733772	1	DECAL, Shift 1,2,3,4,5,6 R1 R2
3	1716532	1	DECAL, Danger Avoid Injury From Auger -(Domestic Only)
3	1727208	1	DECAL, Impeller Warning -(CE/Export Only)
4	1733057	1	DECAL, Danger Amputation Hazard -(Domestic Only)
4	1727207	1	DECAL, Chute Warning -(CE/Export Only)
5	-----	1	DECAL, Opei Certified ANSI -(Domestic Only)
6	1736565	1	DECAL, Snapper, Turtle -was 1733193
7	1736764	1	DECAL, Snapper 1428L, Stripe -was 1734633
7	1734632	1	DECAL, Snapper 1226L, Stripe
7	1734634	1	DECAL, Snapper 1530L, Stripe
7	1734635	1	DECAL, Snapper 1632L, Stripe
7	1736565	1	DECAL, Snapper W/O Turtle
7	1736763	1	DECAL, Snapper, Stripe, 26"
7	1736764	1	DECAL, Snapper, Stripe, 28"
9	728183	1	DECAL, Over Adjustment of Friction Disc -(Domestic Only)
10	1733526	1	DECAL, Warning Lubrication -(Domestic Only)
11	1720454	1	DECAL, Touch Up Paint Orange, Black, Red
12	1733443	1	DECAL, Chute Release Arrow
13	-----	1	STICKER, Serial w/Bar Code
15	725432	1	DECAL, Belt Stretch & Adjustment -(Domestic Only)

Footnotes:

Note *Not a serviceable part.

Engine Group

Note: Unless noted otherwise, use the standard torque specifications

Mfg. No: 1695329

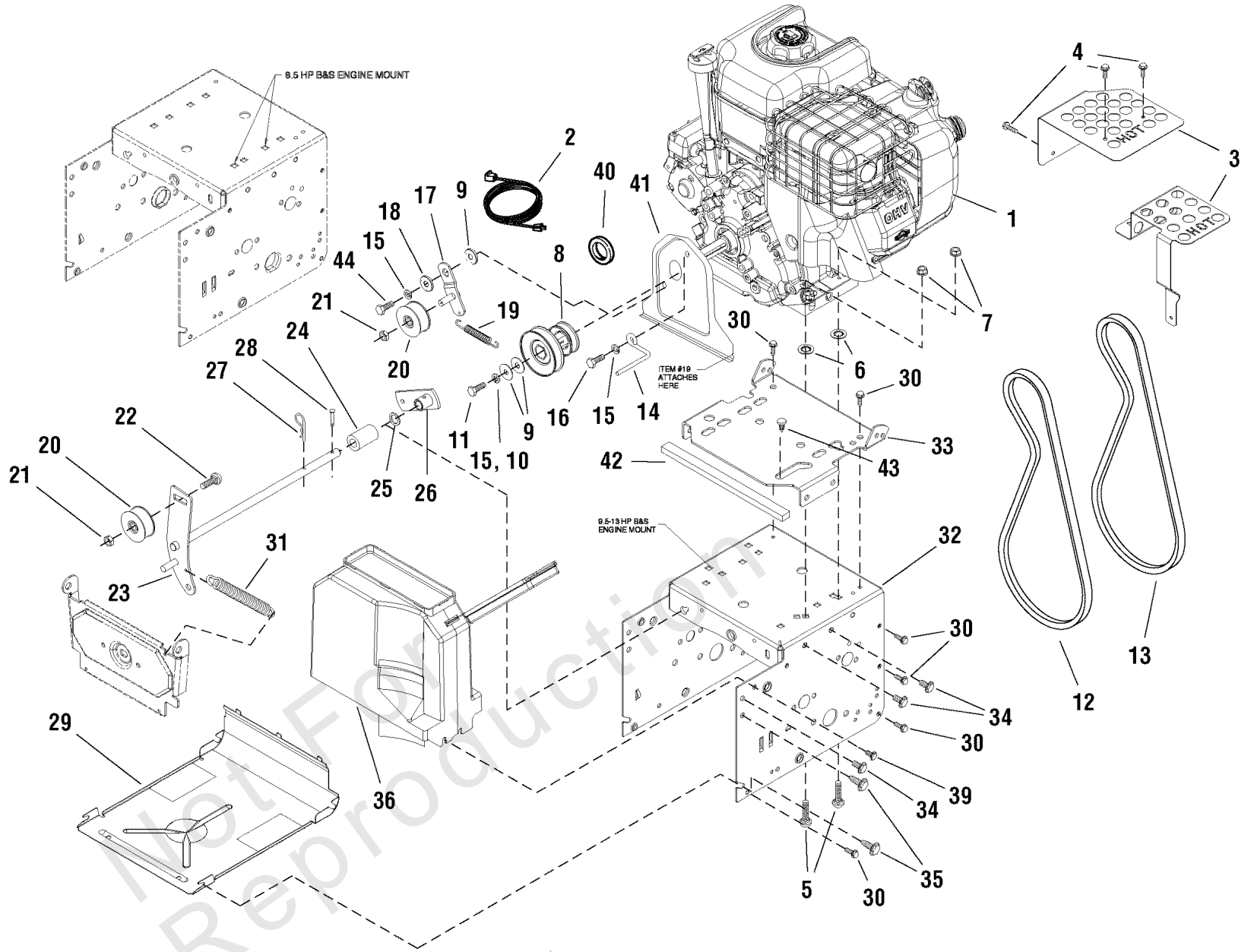

Engine Group

REF NO	PART NO	QTY	DESCRIPTION
1	15C114-0112-E1	1	* ENGINE, 8.5HP B&S Mod. #15C1140112E1
1	20A414-0117-E1	1	* ENGINE, 9.5HP B&S Mod. #20A4140117E1
1	20E214-0118-E1	1	* ENGINE, 10.5HP B&S Mod. #20E2140118E1
1	21C214-0132-E1	1	* ENGINE, 11.5HP B&S Mod. #21C2140132E1
1	15C114-0111-E1	1	* ENGINE, 8.5HP B&S Mod. #15C1140111E1 -(CE/Export)
1	20A414-0119-E1	1	* ENGINE, 9.5HP B&S Mod. #20A4140119E1 -(CE/Export)
1	20E214-0113-E1	1	* ENGINE, 10.5HP B&S Mod. #20E2140113E1 -(CE/Export)
1	21C214-0115-E1	1	* ENGINE, 11.5HP B&S Mod. #21C2140115E1 -(CE/Export)
2	1724064	1	CORD, Electric Start -(Used on Domestic Models)
3	1734698	1	GUARD, Muffler -(Used on Domestic Models)
3	1734732	1	GUARD, Muffler -(Used on Domestic 8.5HP Models)
4	1929477	3	SCREW, Hex Washer Head Taptite
5	720064	4	CARRIAGE BOLT, 5/16-18 x 1-1/2
6	720376	4	NUT, Speed
7	2831277	1	NUT, Hex Flange 5/16-18 Whiz Lock
7	1960686	3	NUT, Hex Flange 5/16-18 ESNA
8	722085	1	PULLEY, Engine
9	1922755	2	WASHER, 3/8
9	1919381	2	WASHER, 5/16-1 -(Used on 8.5HP Models)
10	1916965	1	LOCKWASHER, Spring 3/8
11	1960428	1	CAPSCREW, Hex Head 3/8-24 x 1-1/4 G8
11	1921982	1	CAPSCREW, Hex Head 3/16-24 x 1-1/4 G8 -(Used on 8.5HP Models)
12	1733324	1	V-BELT, 3L 33.13, Drive
13	1733507	1	V-BELT, 4L 38.50, Auger -(Used on 10.5 - 11.5 HP Models)
13	1733051	1	V-BELT, 4L 36.50, Auger -(Used on 8.5 - 9.5 HP Models)
14	1733014	1	STOP, Belt
15	1917356	3/4	LOCKWASHER, Spring 5/16
16	1921515	2	CAPSCREW, Hex Head 5/16-24 x 3/4 G5
17	722090	1	IDLER BRACKET ASSEMBLY, Drive Belt
18	-----	1	BUSHING, Idler Bracket
19	724418	1	SPRING, Extension Idler
20	722378	2	IDLER, Plastic Ball Bearing
21	1960251	2	NUT, Hex Centerlock Jam 3/8-16
22	724823	1	CARRIAGE BOLT, 3/8-16 x 1-1/4
23	722132	1	IDLER, Auger -(Used on 10.5 - 11.5 HP Models)
23	1733055	1	IDLER, Auger -(Used on 8.5 - 9.5 HP Models)
24	722118	1	SPACER/AUGER BRACKET
25	80003590	1	WASHER, 1/2
26	1733451	1	BRACKET & HUB ASSEMBLY, Spring

Footnotes:

Note* See your local Briggs & Stratton Distributor for Parts & Service.

Engine Group

Note: Unless noted otherwise, use the standard torque specifications

Mfg. No: 1695329

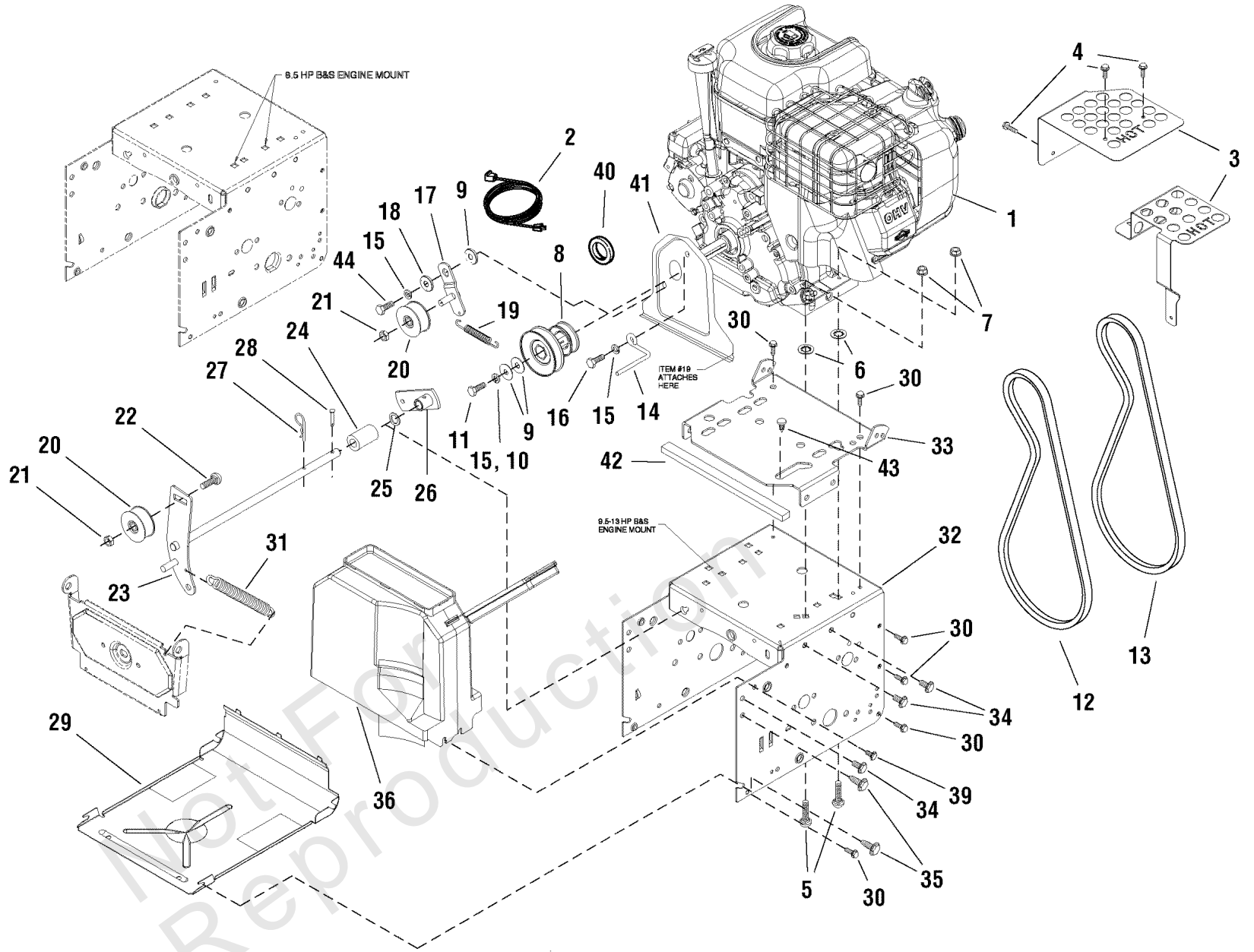

Engine Group

REF NO	PART NO	QTY	DESCRIPTION
27	725367	1	PIN, Hair
28	1735135	1	PIN, Clevis
29	1740906A	1	PANEL, Bottom
30	1927429	12	SCREW, Hex Washer Head Taptite 1/4-20 x 5/8
31	722455	1	SPRING, Extension Auger Idler
32	1733154D	1	FRAME, EZ Turn Axle
32	1739311D	1	FRAME, EZ Turn Axle -(Used on 8.5HP Models) was 1740572D
33	1733583D	1	PLATE, Engine Mount
34	1924856	4	SCREW, Hex Washer Head Taptite 5/16-18 x 1/2
35	1664847	6	SCREW, Hex Washer Head Taptite 5/16-18 x 3/4
36	1733923	1	COVER, Belt w/Toolbox B&S
39	722887	2	SCREW, 1/4-AB x 3/4 Hex
40	1733898	1	SHAFT, Seal
41	1733868A	1	SEAL, Plate
42	1733897	1	SEAL, Strip
43	1733924	1	CLIP, Pine Tree
44	725996	1	CAPSCREW, Hex Head 5/16-24 x 1 G8

Not For
Reproduction

Footnotes:

Note* See your local Briggs & Stratton Distributor for Parts & Service.

Handle & Controls Group

Note: Unless noted otherwise, use the standard torque specifications

Mfg. No: 1695329

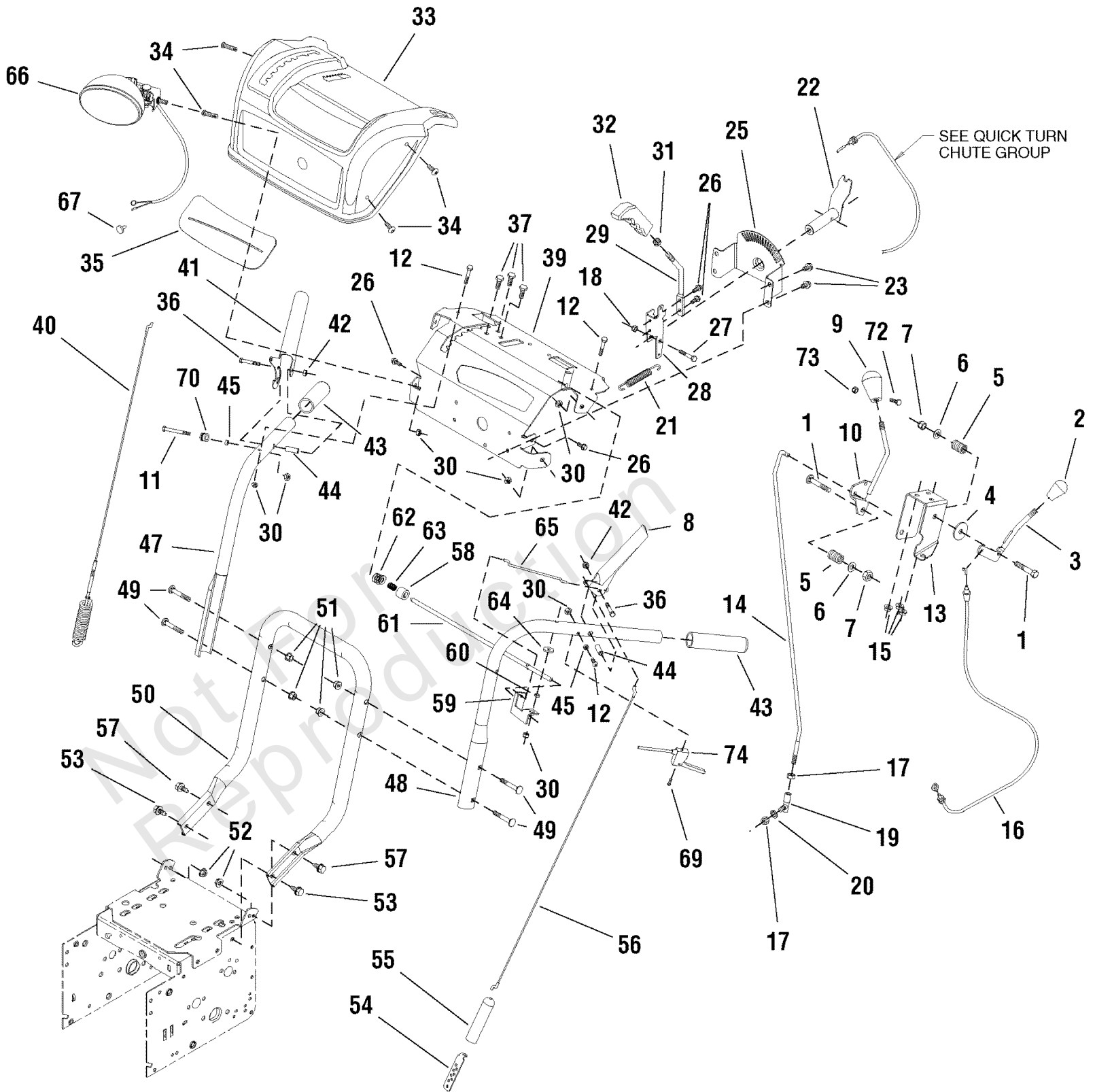

Handle & Controls Group

REF NO	PART NO	QTY	DESCRIPTION
1	1923701	2	CAPSCREW, Hex Head 3/8-16 x 2 G5
2	1732470	1	KNOB, Interior Thread 3/8-16
3	1732427	1	ROD, 3/8 Diameter 5" Large, 3/8-16 x 1 Chute
4	1924356	1	WASHER, 3/8
5	-----	2	SPRING
6	1918266	2	WASHER, 3/8
7	1919439	2	NUT, Hex Lock ESNA Light 3/8-16
8	1722667	1	HANDLE, Clutch L.H.
9	1733192	1	KNOB, Slot Speed
10	1733205	1	ROD & PLATE ASSEMBLY, Speed Control
11	1923282	1	CAPSCREW, Hex Head 1/4-20 x 2-1/2 G5
12	1921962	3	CAPSCREW, Hex Head 1/4-20 x 1-3/4 G5
13	1733045A	1	BRACKET, Trac & Deflector Control
14	1734354	1	ROD
15	1931277	3	NUT, Hex Flange 5/16-18, Whiz Lock Small
16	1732971	1	CABLE, Deflector Control
17	2820263	2	NUT, Hex 5/16-24
18	1960608	1	NUT, Hex Flange 1/4-20 Centerlock Large
19	724360	1	BALLJOINT, Steel
20	1917356	1	LOCKWASHER, Spring 5/16
21	1732970	1	SPRING, Extension
22	1732365	1	TUBE & BRACKET ASSEMBLY, Cable Support
23	1924856	4	SCREW, Hex Washer Head Taptite 5/16-18 x 1/2
25	1732364	1	SUPPORT, Chute Control 14GA
26	1927429	4	SCREW, Hex Washer Head Taptite 1/4-20 x 5/8
27	1732944	1	BOLT, Shoulder 1/4-20
28	1733142	1	BRACKET, Support Quick Turn
29	1732369	1	ROD, Chute
30	1920397	8	NUT, Hex Lock ESNA Light 1/4-20
31	1917421	1	NUT, Hex Jam 3/8-16
32	723122	1	GRIP, Lever
33	1733777D	1	COVER, Panel
34	1960715	4	SCREW, Truss Head Torx Drive 1/4-20 x 3/4
35	1733204	1	BELLOWS, Black Rubber Quick Turn
36	1922837	2	CAPSCREW, Hex Head 1/4-20 x 1-1/2 G5
37	1931333	3	CARRIAGE BOLT, 5/16-18 x 3/4 G5
39	1732064A	1	SUPPORT, Dash Panel Cover
40	1732471	1	CABLE & SPRING ASSEMBLY, Auger Drive R.H.
41	1722638	1	HANDLE, Clutch R.H.
42	1923358	2	NUT, Hex Centerlock 1/4-20
43	1726317	2	GRIP
44	1715655	2	SPACER
45	1678392	2	SPACER
47	1734587A	1	HANDLE, Upper R.H.
48	1734586A	1	HANDLE, Upper L.H.
49	1960723	4	CARRIAGE BOLT, 5/16-18 x 2-1/4 G5
50	1732781A	1	HANDLE, Lower
51	1960686	4	NUT, Hex Flange 5/16-18
52	1935048	2	NUT, Hex Flange 5/16-18 Two-Way Lock
53	1664847	2	SCREW, Hex Washer Head Taptite 5/16-18 x 3/4
54	723259	1	BRACKET, Cable Adjusting

Handle & Controls Group

Note: Unless noted otherwise, use the standard torque specifications

Mfg. No: 1695329

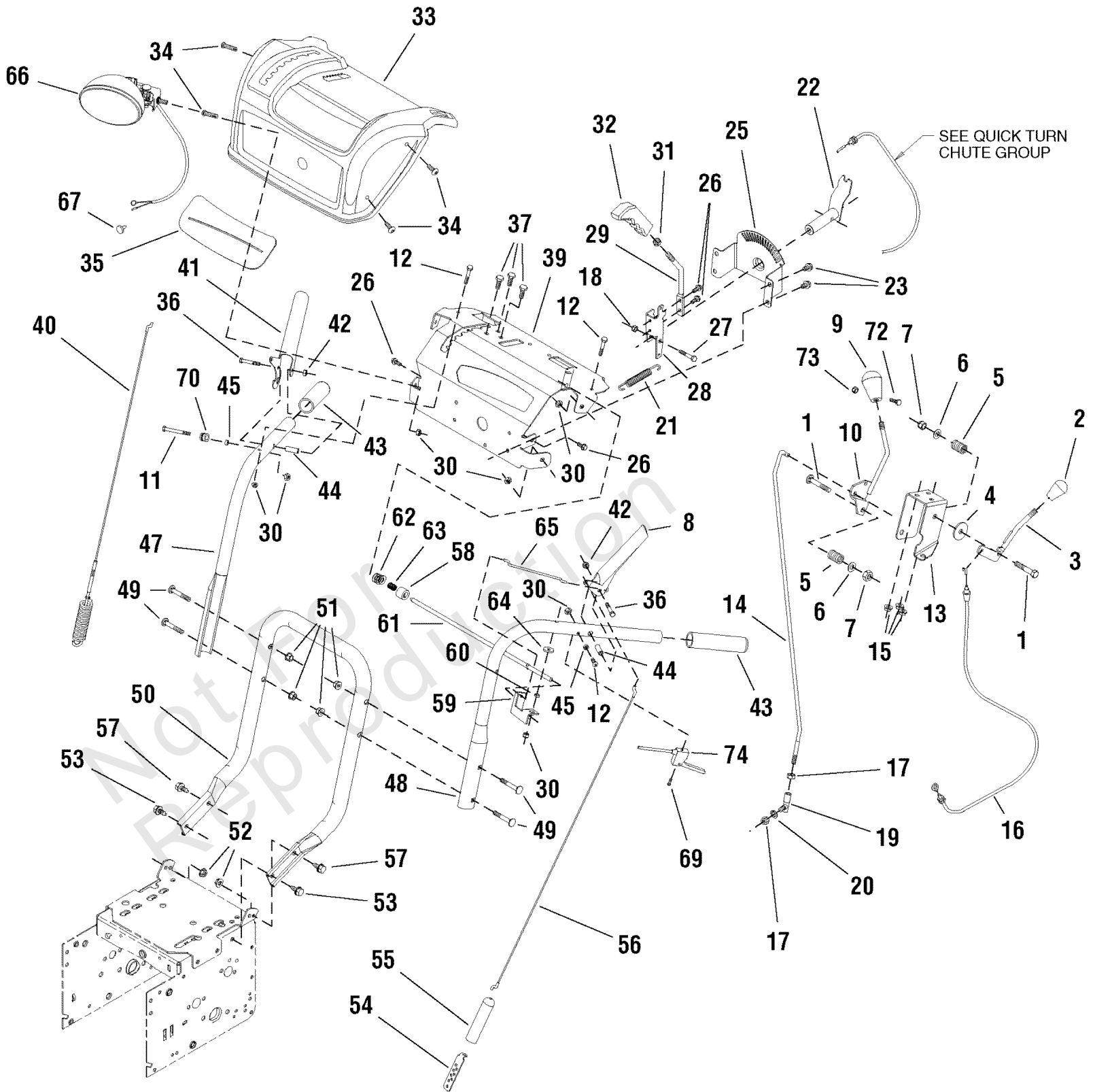

Handle & Controls Group

REF NO	PART NO	QTY	DESCRIPTION
55	723154	1	BOOT, Spring End Cover
56	727331	1	CABLE,
57	1921333	2	CAPSCREW, Hex Head 5/16-18 x 1 G5
58	1679166	1	SPACER, Powdered Metal
59	1733505A	1	BRACKET, Free Hand Control 12GA
60	1733095	1	SPACER, Powdered Metal
61	-----	1	ROD & SPRING ASSEMBLY, w/Pin
62	80003590	4	WASHER, 1/2
63	-----	1	SPRING, Compression
64	1960353	1	WASHER, 1/4
65	1722630	1	ROD, Hold Down E-Coat
66	1732321	1	HEADLIGHT ASSEMBLY, Oval Amber
67	1704351	5	FASTENER, Panel
69	-----	1	SCREW, Pan Head Torx #10 x 1/2 Thick Cut
70	724621	1	SPOOL CABLE, Auger Control
72	1960589	1	SCREW, Round Head Phillips #10-24 x 3/4
73	1933896	1	NUT, Hex Lock 10-24 w/Nylon Insert
74	-----	1	CABLE & HANDLE ASSEMBLY

Not For
Reproduction

Traction Drive Group - EZ Turn - 28" Model

Note: Unless noted otherwise, use the standard torque specifications

Mfg. No: 1695329

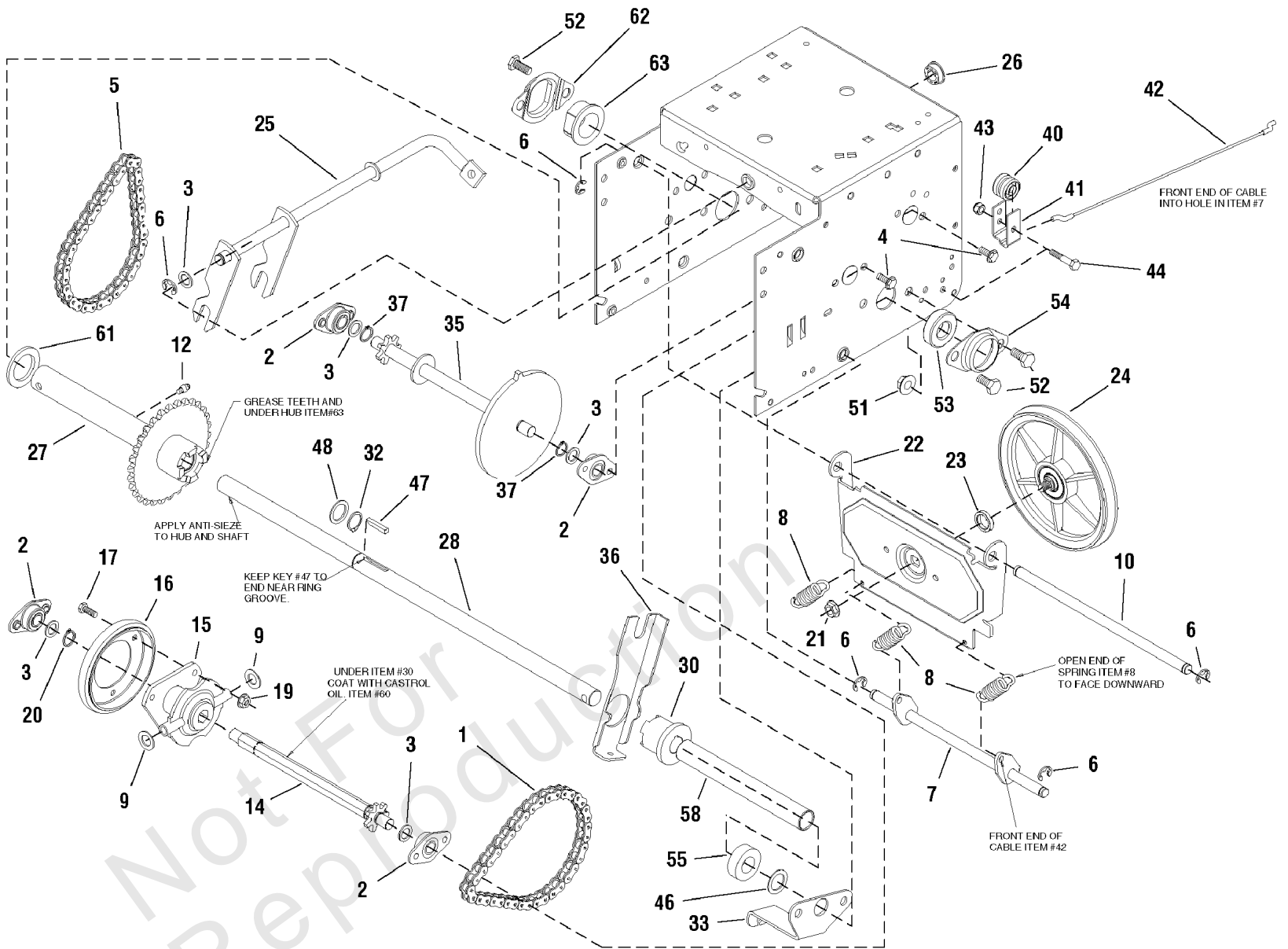

Traction Drive Group - EZ Turn - 28" Model

REF NO	PART NO	QTY	DESCRIPTION
1	724613	1	CHAIN, Roller
2	723655	4	RETAINER & BUSHING ASSEMBLY
3	724619	5	WASHER
4	1924856	8	SCREW, Hex Washer Head Taptite 5/16-18 x 1/2
5	724627	1	CHAIN, Roller
6	721910	5	RETAINER, Ring 7/16
7	722377	1	SPRING LINK ASSEMBLY
8	722423	3	SPRING, Extension
9	80003590	2	WASHER, 1/2
10	722082	1	AXLE, Swing Plate
12	2812808	1	FITTING, Lube
14	722083	1	HEX SHAFT & SPROCKET ASSEMBLY
15	723694	1	HUB, Friction Wheel & Bearing
16	722185	1	WHEEL, Friction
17	1921959	3	CAPSCREW, Hex Head 1/4-20 x 5/8 G5
19	1928372	3	NUT, Hex KEPS 1/4-20
20	1733326	1	RING, Retaining Extension
21	722391	1	NUT, 3/8-24 Flange Lock
22	722069	1	PLATE, Swinging
23	722110	1	SPACER, Friction Pulley
0060	1656916SM	4	WASHER, Spring, 0.475
24	722092	1	FRICITION PULLEY ASSEMBLY
25	722087	1	SPEED SELECT ASSEMBLY
26	724636	1	BEARING, Flange
27	1733085	1	SPROCKET & HUB ASSEMBLY, W/Bushings
28	1732381	1	AXLE
30	1732382	1	GEAR, Clutching Powdered Metal
32	2827732	1	RING, Retaining Extension
0140	703228	2	SCREW, Washer Head Taptite, 5/16-18 X 3/4
0170	885723BMYP	1	SUPPORT, Idler Arm
35	1732389	1	SPROCKET & SHAFT ASSEMBLY
37	2860386	2	RING, Retaining Extension
40	724621	1	SPOOL CABLE, Auger Control
41	722070	1	BRACKET, Cable Spool
42	722095	1	CABLE, Front Drive Lower All
43	1920397	1	NUT, Hex Lock ESNA Light 1/4-20
44	1922837	1	CAPSCREW, Hex Head 1/4-20 x 1-1/2 G5
46	725394	1	WASHER, Flat
48	1960114	1	WASHER, 3/4
51	1928352	4	NUT, Hex Flange 3/8-16 Whiz Lock
52	1921965	4	CAPSCREW, Hex Head 3/8-16 x 3/4 G5
53	724409	1	BEARING, Ball
54	724347	1	RETAINER, Bearing
55	722228	1	COLLAR, Locking
58	1720298	1	SPRING, Compression
61	2860169	1	WASHER, 1-3/16
62	1733101	1	RETAINER, Bushing
63	1720305	1	BUSHING, Plastic

Footnotes:

0

Wheel & Tire Group

Note: Unless noted otherwise, use the standard torque specifications

Mfg. No: 1695329

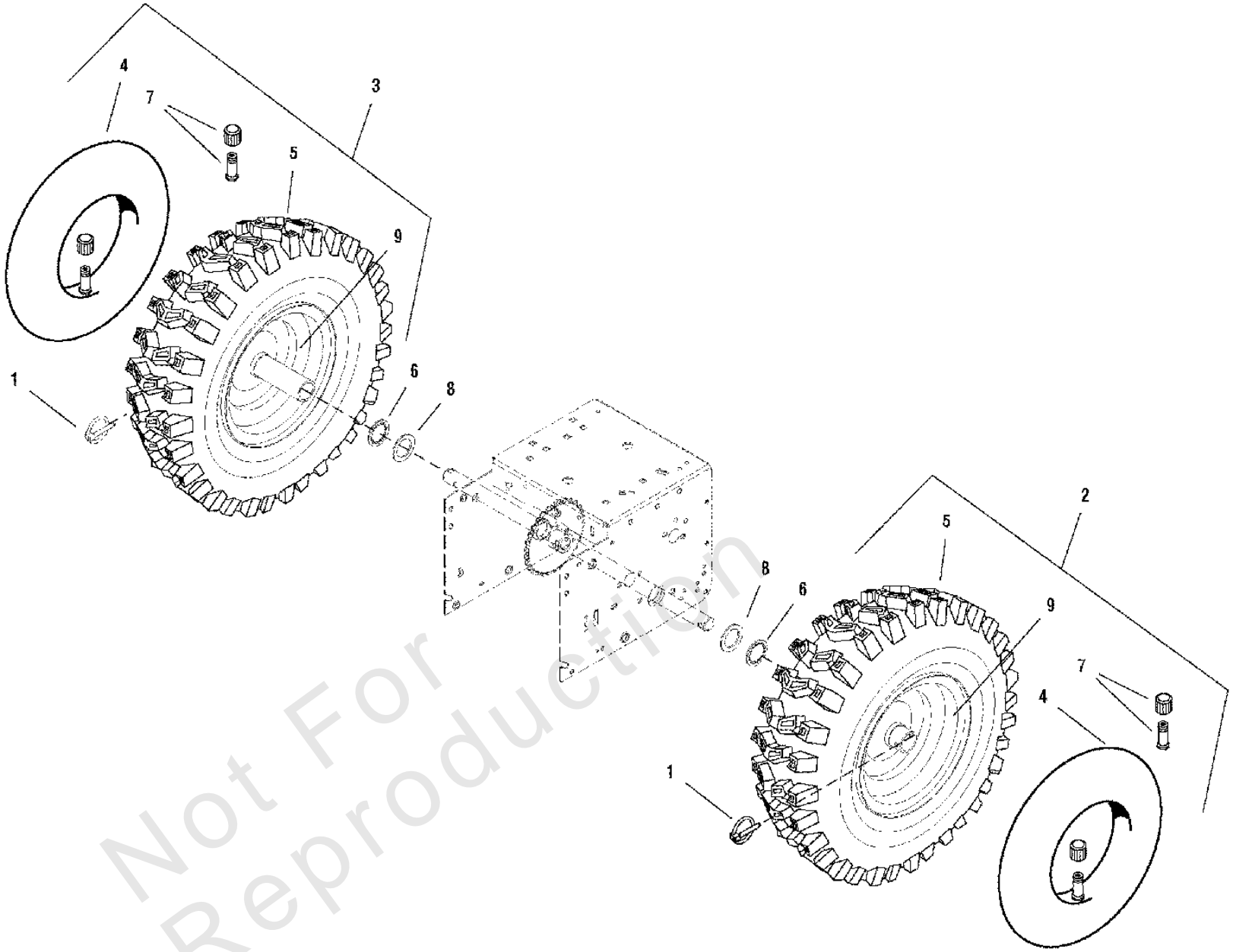

Wheel & Tire Group

REF NO	PART NO	QTY	DESCRIPTION
1	1731186	2	PIN, Klik .313 x 1.97 -(Used on 26" Models)
1	1679697	2	PIN, Klik 1/4 x 1-3/4 -(Used on 28", 30" & 32" Models)
2	1732935	1	WHEEL & TIRE ASSEMBLY, 15 x 5 L.H & R.H. -(Used on 26" Models)
2	1723169	1	WHEEL & TIRE ASSEMBLY, 15 x 5 L.H. -(Used on 28" Models)
2	1714235	1	WHEEL & TIRE ASSEMBLY, 16 x 4.8 L.H. -(Used on 30" & 32" Models)
3	1732935	1	WHEEL & TIRE ASSEMBLY, 15 x 5 L.H & R.H. -(Used on 26" Models)
3	1733089	1	WHEEL & TIRE ASSEMBLY, 15 x 5 R.H. -(Used on 28" Models)
3	1720306	1	WHEEL & TIRE ASSEMBLY, 16 x 4.8 R.H. -(Used on 30" & 32" Models)
4	1664090	1	TUBE, Tire 4.10/3.50-6 L.H. -(Used on 28" Models)
4	2153038	1	TUBE, Tire 4.80/4.00 L.H. & R.H. -(Used on 30" & 32" Models)
5	1723287	1	TIRE, 15 x 5.00-6, 2 PLY, KENDA L.H. -(Used on 26" & 28" Models)
5	1612000	1	TIRE, 4.80/4.00-8 L.H. & R.H. -(Used on 30" & 32" Models)
6	1657528	2	RETAINING RING, Extension, #75 3/4 Self Lock -(Used on 26" Models)
7	2172353	1	VALVE STEM & CAP -(Used on All Models)
8	725394	2	WASHER, Flat -(Used on 26" Models)
9	1723286	1	HUB, Wheel L.H. -(Used on 28" Models)
9	1714242	1	HUB, Wheel 3.756 Wide 8. L.H. -(Used on 30" & 32" Models)
9	1720307	1	HUB, Wheel 3.75 Wide 8. R.H. -(Used on 30" & 32" Models)

Hardware Identification & Torque Specifications

Torque Specification Chart								
FOR STANDARD METRIC MACHINE HARDWARE (Tolerance ± 20%)								
Property Class	5.6		8.8		10.9		12.9	
	Class 5.6		Class 8.8		Class 10.9		Class 12.9	
Size Of Hardware	in/lbs	Nm.	in/lbs	Nm.	in/lbs	Nm.	in/lbs	Nm.
	ft/lbs		ft/lbs		ft/lbs		ft/lbs	
M3	5.88	.56	13.44	1.28	19.2	1.80	22.92	2.15
M4	13.44	1.28	30.72	2.90	43.44	4.10	52.56	4.95
M5	26.4	2.50	60.96	5.75	5.97	8.10	7.15	9.7
M6	44.64	4.3	7.3	9.9	10.3	14	12.1	16.5
M7	5.2	7.1	12.1	16.5	16.9	23	19.9	27
M8	7.7	10.5	17.7	24	25	34	29	40
M10	15	21	35	48	50	67	59	81
M12	26	36	61	83	86.2	117	103	140
M14	42	58	101	132	136	185	162	220
M16	64	88	147	200	210	285	250	340
M18	89	121	202	275	287	390	346	470
M20	126	171	290	390	405	550	486	660
M22	169	230	390	530	559	745	656	890
M24	217	295	497	375	708	960	840	1140
M27	320	435	733	995	1032	1400	1239	1680
M30	435	590	995	1350	1401	1900	1681	2280
M33	590	800	1349	1830	1902	2580	2278	3090
M36	759	1030	1740	2360	2441	3310	2935	3980
M39	988	1340	2249	3050	3163	4290	3798	5150

Torque Specification Chart						
FOR STANDARD MACHINE HARDWARE (Tolerance ± 20%)						
Hardware Grade	No Marks		SAE Grade 5		SAE Grade 8	
	SAE Grade 2		SAE Grade 5		SAE Grade 8	
Size Of Hardware	in/lbs	Nm.	in/lbs	Nm.	in/lbs	Nm.
	ft/lbs		ft/lbs		ft/lbs	
8-32	19	2.1	30	3.4	41	4.6
8-36	20	2.3	31	3.5	43	4.9
10-24	27	3.1	43	4.9	60	6.8
10-32	31	3.5	49	5.5	68	7.7
1/4-20	66	7.6	8	10.9	12	16.3
1/4-28	76	8.6	10	13.6	14	19.0
5/16-18	11	15.0	17	23.1	25	34.0
5/16-24	12	16.3	19	25.8	29	34.0
3/8-16	20	27.2	30	40.8	45	61.2
3/8-24	23	31.3	35	47.6	50	68.0
7/16-14	30	40.8	50	68.0	70	95.2
7/16-20	35	47.6	55	74.8	80	108.8
1/2-13	50	68.0	75	102.0	110	149.6
1/2-20	55	74.8	90	122.4	120	163.2
9/16-12	65	88.4	110	149.6	150	204.0
9/16-18	75	102.0	120	163.2	170	231.2
5/8-11	90	122.4	150	204.0	220	299.2
5/8-18	100	136	180	244.8	240	326.4
3/4-10	160	217.6	260	353.6	386	525.0
3/4-16	180	244.8	300	408.0	420	571.2
7/8-9	140	190.4	400	544.0	600	816.0
7/8-14	155	210.8	440	598.4	660	897.6
1-8	220	299.2	580	788.8	900	1,244.0
1-12	240	326.4	640	870.4	1,000	1,360.0

The guides and ruler furnished below are designed to help you select the appropriate hardware.



Nut, M8

Thread Diameter (mm)

Inside Diameter (in) Threads per inch

Nut, 1/2-16



Screw, M8- 1.25 x 25

Thread Diameter (mm) Distance between threads (mm) Body Length (mm)

Body Diameter Threads per inch Body Length (in)

Screw, 1/2- 16 x 2



Standard Hardware Sizing

When a washer or nut is identified as 1/2" (M8), this is the *Nominal size*, meaning the *inside diameter* is 1/2 inch (8mm metric thread diameter); if a second number is present it represents the *threads per inch* (distance between threads).

When bolt or capscrew is identified as 1/2 - 16 x 2" (M8 - 1.25 x 50), this means the *Nominal size*, or body diameter is 1/2 inch (8mm metric thread diameter), the second number, 16, represents the *threads per inch*, (*distance between threads*). The final number is the body length of the bolt or screw, 2 inches (50mm).

NOTES

- These torque values are to be used for all hardware excluding: locknuts, self-tapping screws, thread forming screws, sheet metal screws and socket head setscrews.
- Recommended seating torque values for locknuts:
 - for prevailing torque locknuts - use 65% of grade 5 torques.
 - for flange whizlock nuts and screws - use 135% of grade 5 torques.
- Unless otherwise noted on assembly drawings, all torque values must meet this specification.

Common Hardware Types

Hex Head Capscrew

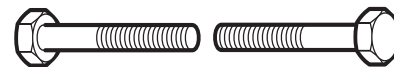

Washer



Carriage Bolt



Hex Nut

Wrench & Fastener Size Guide

1/4" Bolt or Nut Wrench—7/16"	5/16" Bolt or Nut Wrench—1/2"	3/8" Bolt or Nut Wrench—9/16"	7/16" Bolt or Nut Wrench (Bolt)—5/8" Wrench (Nut)—11/16"	1/2" Bolt or Nut Wrench—3/4"
M6 Bolt or Nut Wrench—10mm	M8 Bolt or Nut Wrench—13mm	M10 Bolt or Nut Wrench—17mm	M12 Bolt or Nut Wrench—19mm	M14 Bolt or Nut Wrench—22mm

