



PARTS CATALOG

HEDGE TRIMMER HCR-1501(37)

37002761 -

CE

P014-003661-15B

1. GEAR CASE, CUTTER

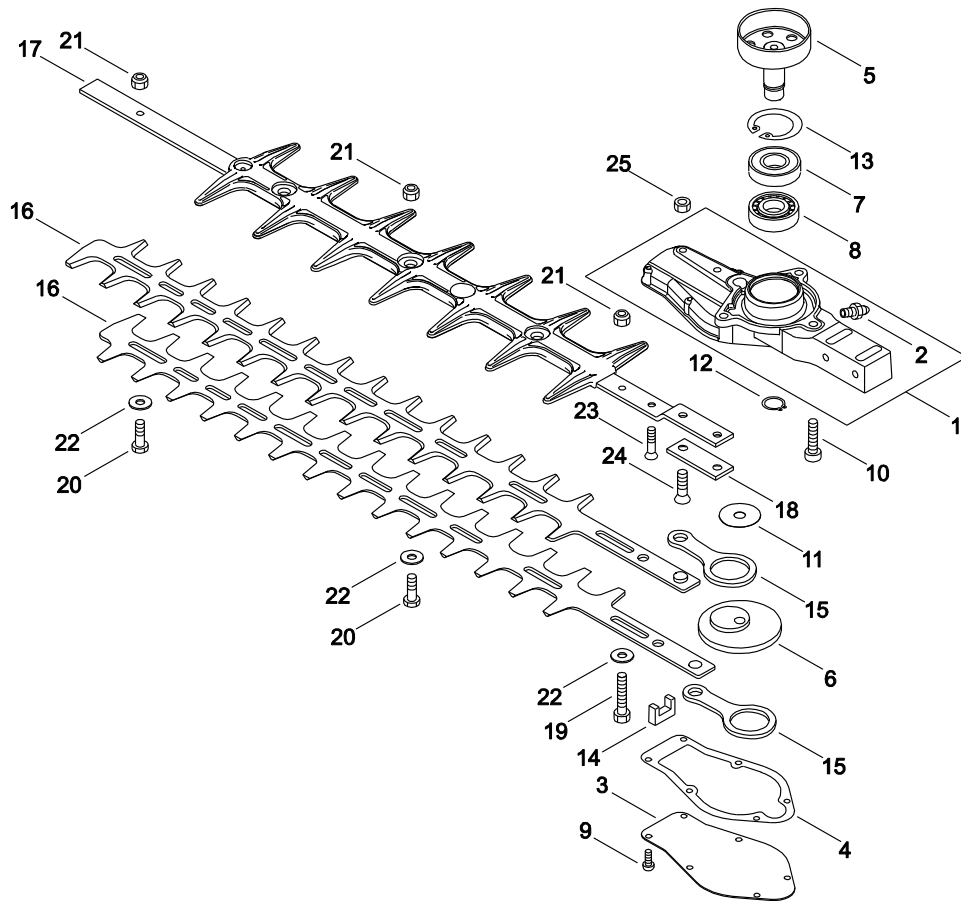

KEY	LV	PART NUMBER	Q'TY	DESCRIPTION	REMARKS	NOTE1	NOTE2
1		P021-045620	1	CASE ASY, GEAR			
2	+	880110-10860	1	NIPPLE, GREASE			
3		610411-05361	1	LID, GEARCASE			
4		610414-05360	1	GASKET, GEAR HOUSING			
5		A556-001620	1	DRUM, CLUTCH	50 T:1.4		
6		610312-04560	1	GEAR			
7		900812-06202	1	BEARING, BALL 6202	6202DDU(LLU)		
8		900810-36202	1	BEARING, BALL 6202	6202/C3		
9		V804-000040	6	BOLT, TORX 4	TB-4*10 10.9		
10		V806-000130	3	BOLT, TORX 6			
11		610350-04560	1	WASHER			
12		900701-00014	1	CIRCLIP 14	CS-14		
13		900702-00035	1	CIRCLIP 35	CR-35		
14		610425-04560	1	SEAL			
15		C532-000121	2	ROD, CONNECTING			
16		X412-000630	2	CUTTER			
17		P021-045630	1	CUTTER SUPPORT ASY			
18		610440-04560	1	HOLDER, FRAME			
19		699115-05360	1	BOLT			
20		V204-000570	4	BOLT			
21		433022-06460	5	NUT			
22		V304-000240	5	WASHER			
23		900212-05030	1	SCREW (5*30*P0.8)	+SF5*30		
24		900212-06025	2	SCREW 6*25	+SF6*25		
25		900500-00006	2	NUT 6	6		

2. CYLINDER, CRANKCASE, PISTON

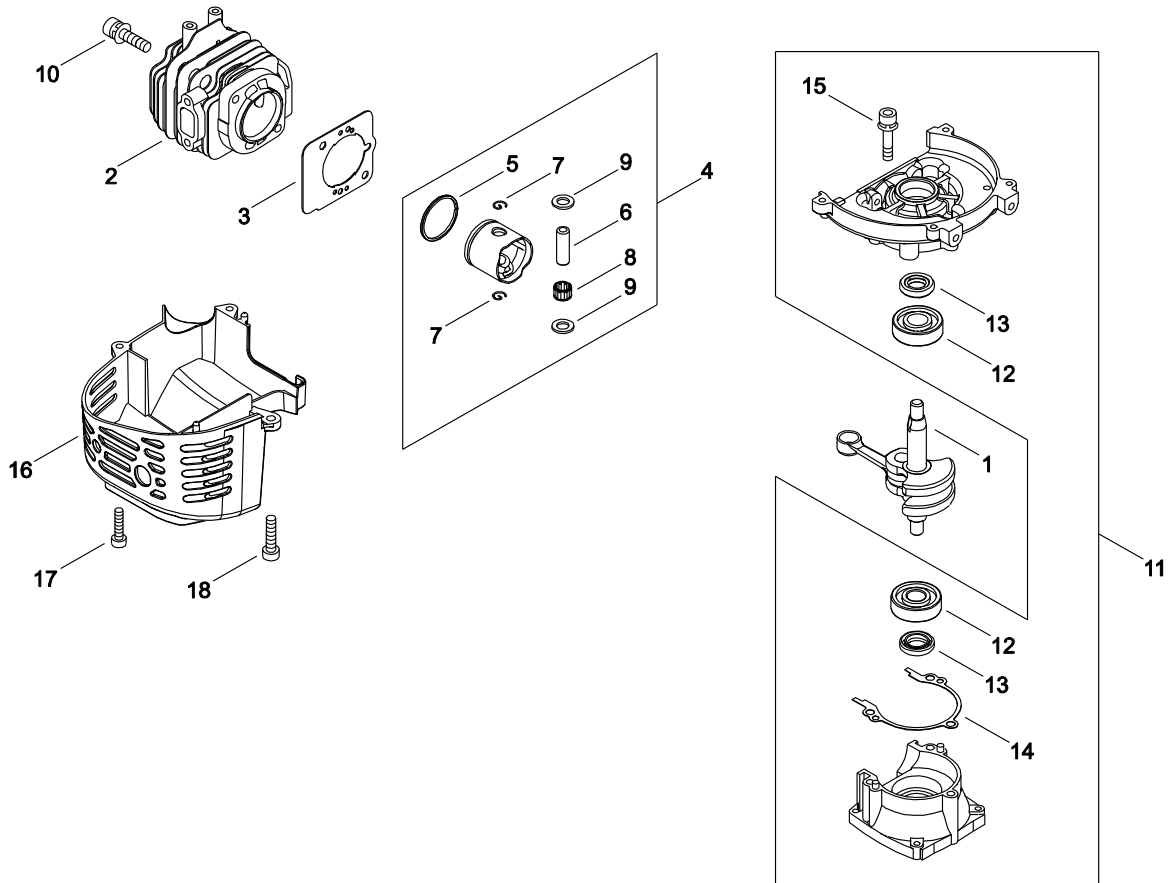

KEY	LV	PART NUMBER	QTY	DESCRIPTION	REMARKS	NOTE1	NOTE2
1		A011-000313	1	CRANKSHAFT,ASM			
2		A130-000550	1	CYLINDER			
3		V100-000160	1	GASKET,CYL			
4		P021-007772	1	PISTON KIT			
5	+	A101-000090	1	RING,PISTON			
6	+	100013-11520	1	PIN, PISTON			
7	+	100015-04630	2	CIRCLIP, PISTON PIN			
8	+	100113-05930	1	BEARING, NEEDLE	8*12*8		
9	+	100014-08960	2	SPACER, PISTON PIN			
10		900162-05022	2	BOLT, H.S. 5*22	5*22 W,SW		
11		100204-11521	1	CRANKCASE KIT			
12	+	94035-36201	2	BEARING BALL	6201X3JR2C3		
13	+	100212-42031	2	OILSEAL	ISCD 12*22*4.5		
14	+	100242-42030	1	GASKET, CRANKCASE			
15	+	900162-05028	3	BOLT, H.S. 5*28	5*28 W,SW		
16		A160-002590	1	COVER,CYLINDER			
17		V804-000010	2	BOLT, TORX 4	TT-4*16 DG 10.9		
18		V805-000150	1	BOLT, TORX 5	TB-5*16 10.9		

3. MAGNETO, CLUTCH

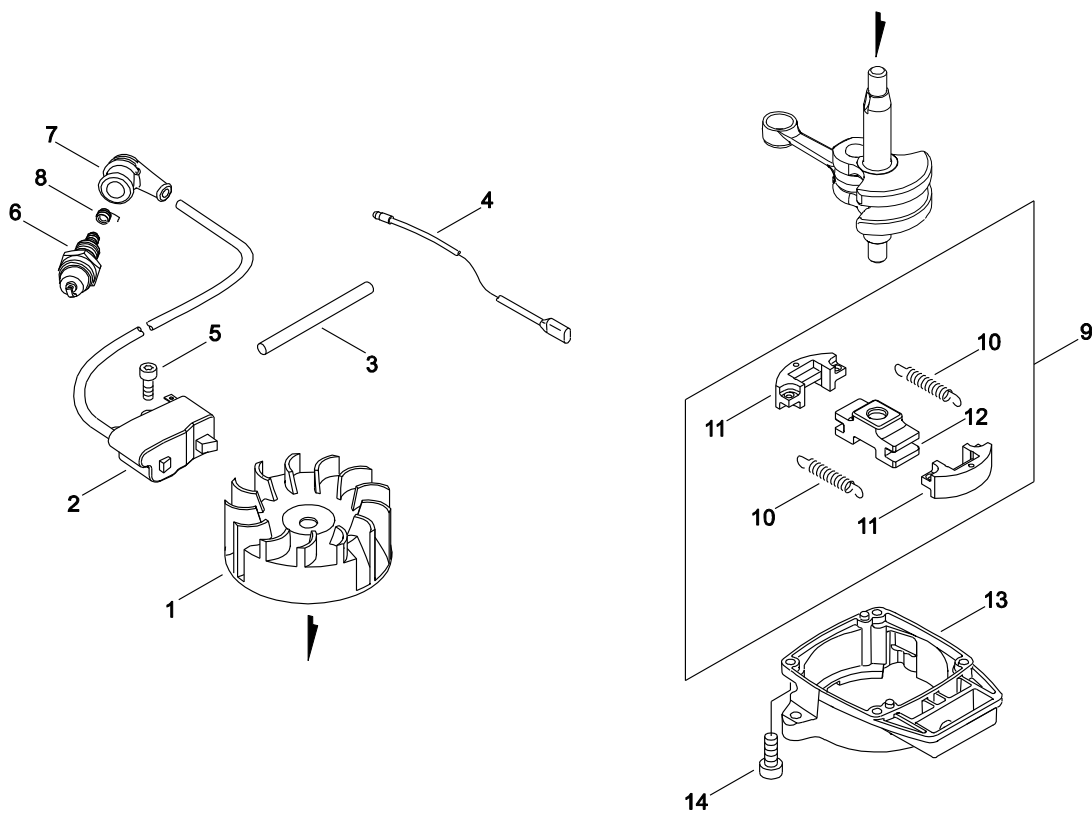

KEY	LV	PART NUMBER	Q'TY	DESCRIPTION	REMARKS	NOTE1	NOTE2
1		A409-000150	1	ROTOR,MAGNETO			
2		A411-000210	1	COIL,IGNITION			
3		V475-007510	1	TUBE			
4		V485-000870	1	LEAD	L=190,#187,CA104		
5		V804-000070	2	BOLT, TORX 4	TB-4*20 12.9		
6		A425-000000	1	SPARKPLUG	BPMR8Y		
7		A427-000013	1	CAP,SPARK PLUG			
8		A426-000010	1	TERMINAL,SPARKPLUG			
9		A056-000740	1	CLUTCH ASY			
10	+	A566-000000	2	SPRING, CLUTCH			
11	+	175017-44331	2	SHOE, CLUTCH			
12	+	A552-000380	1	HUB, CLUTCH			
13		A570-000310	1	CASE,CLUTCH			
14		V804-000060	4	BOLT, TORX 4	TB-4*16 10.9		

4. AIR CLEANER, CARBURETOR

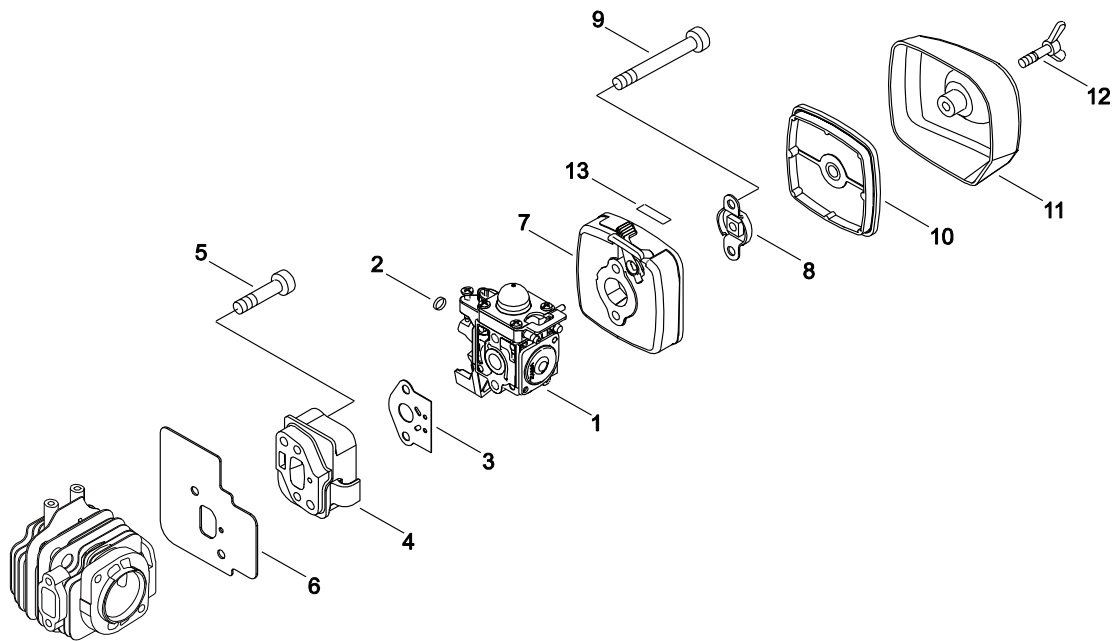

KEY	LV	PART NUMBER	Q'TY	DESCRIPTION	REMARKS	NOTE1	NOTE2
1		A021-001673	1	CARBURETOR,DIAPHRAGM			
2		V490-001100	1	CLIP			
3		V103-001580	1	GASKET,INTAKE			
4		A200-000300	1	INSULATOR, INTAKE			
5		V805-000170	2	BOLT, TORX 5	TB-5*25 10.9		
6		V103-001590	1	GASKET,INTAKE			
7		P021-004480	1	CASE, AIR CLEANER			
8		129011-52730	1	PLATE, PREVENT			
9		V805-000100	2	BOLT, TORX 5	TB-5*65 10.9		
10		A226-001410	1	ELEMENT,AIR FILTER			
11		130313-05863	1	LID, AIR CLEANER			
12		210417-52730	1	BOLT, WING	5*20		
13		890332-52730	1	LABEL, CHOKE			

5. FUEL TANK

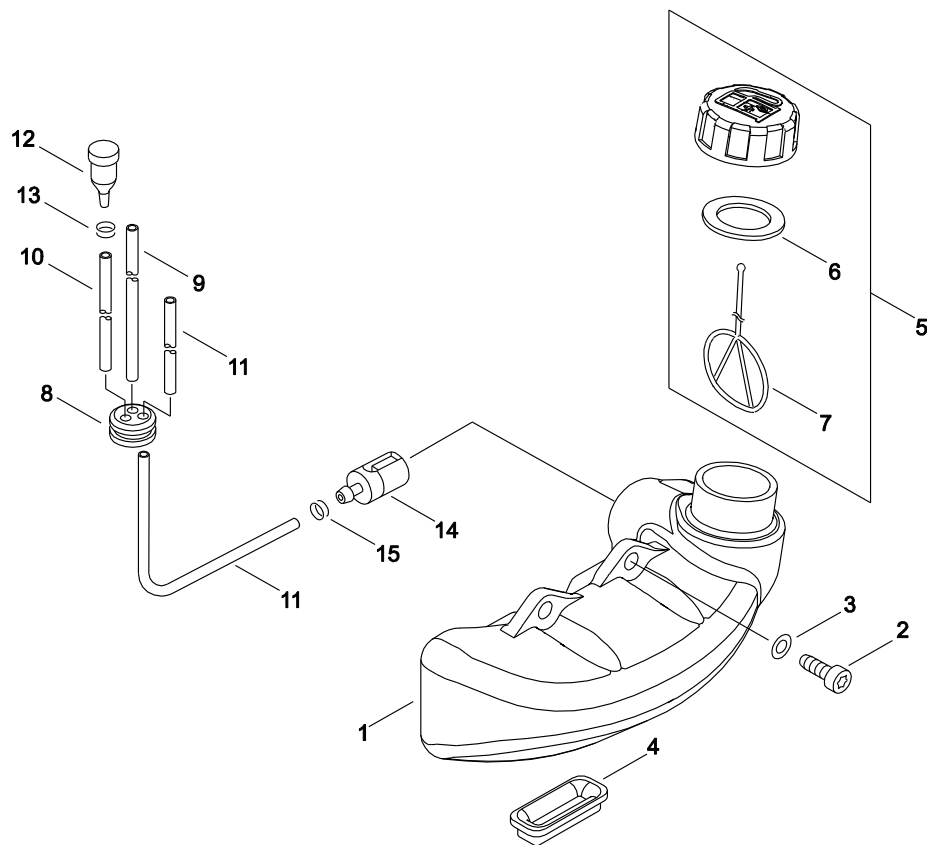

KEY	LV	PART NUMBER	Q'TY	DESCRIPTION	REMARKS	NOTE1	NOTE2
1		A350-000041	1	TANK,FUEL			
2		V805-000000	2	BOLT, TORX 5	TT-5*16 DG 10.9		
3		900603-00005	2	WASHER 5	5.5*12*0.8		
4		131920-61830	1	CUSHION, FUEL TANK			
5		P021-012210	1	CAP,FUEL ASY			
6	+	131016-55830	1	GASKET, FUEL CAP			
7	+	A365-000060	1	CONNECTOR,CAP	L=123		
8		132115-46730	1	GROMMET, FUEL			
9		V470-000580	1	PIPE	3*5*195		
10		V471-001200	1	PIPE	3*5*70 NBR		
11		132010-40830	1	PIPE 3* 6* 75	3*6*75 YL		
12		A356-000031	1	VALVE,CHECK			
13		V490-001240	1	CLIP			
14		131205-07321	1	STRAINER, FUEL			
15		V490-001240	1	CLIP			

6. MUFFLER

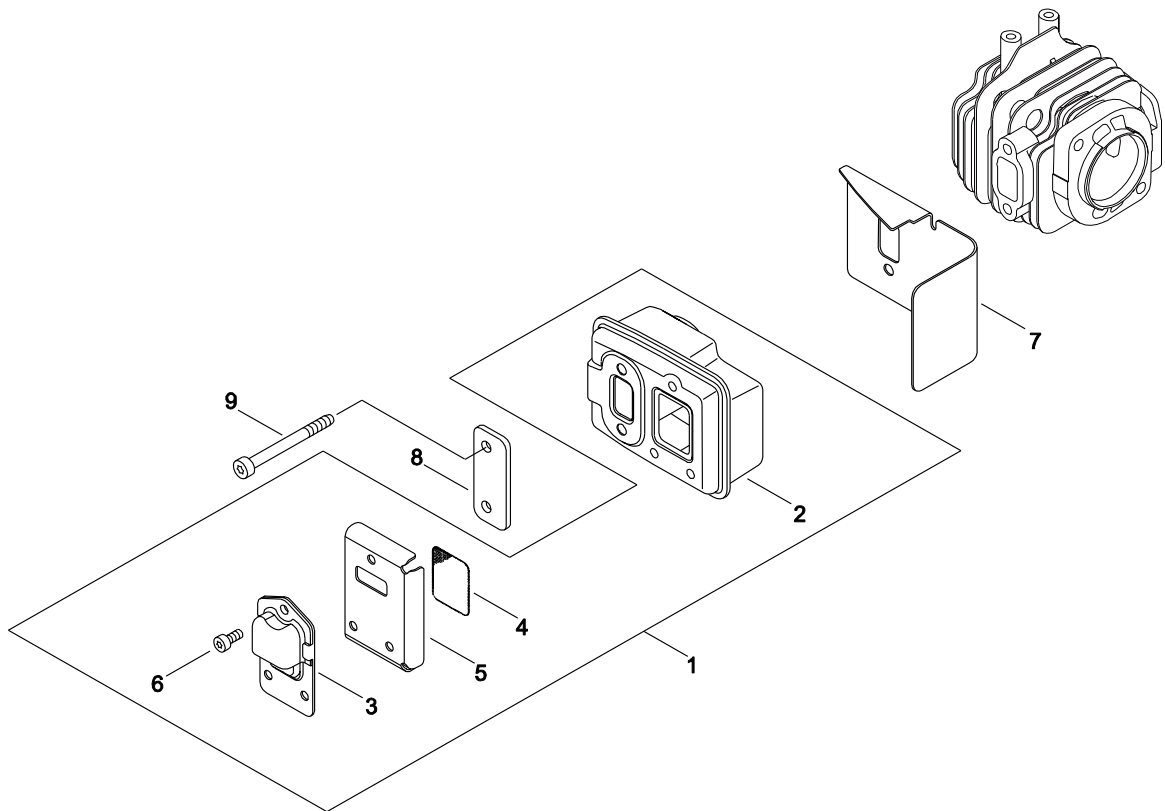

KEY	LV	PART NUMBER	Q'TY	DESCRIPTION	REMARKS	NOTE1	NOTE2
1		P021-045640	1	MUFFLER ASY			
2	+	A300-000521	1	MUFFLER,EXHAUST			
3	+	A313-000700	1	GUIDE,EXH	ID#1090		
4	+	145862-40630	1	SCREEN, MUFFLER			
5	+	V104-000072	1	GASKET,EXHAUST			
6	+	V804-000030	3	BOLT, TORX 4	TB-4*8 10.9		
7		V104-001990	1	GASKET,EXHAUST			
8		V150-000371	1	PLATE,EYE			
9		V805-000190	2	BOLT, TORX 5	TB-5*55 12.9		

7. RECOIL STARTER

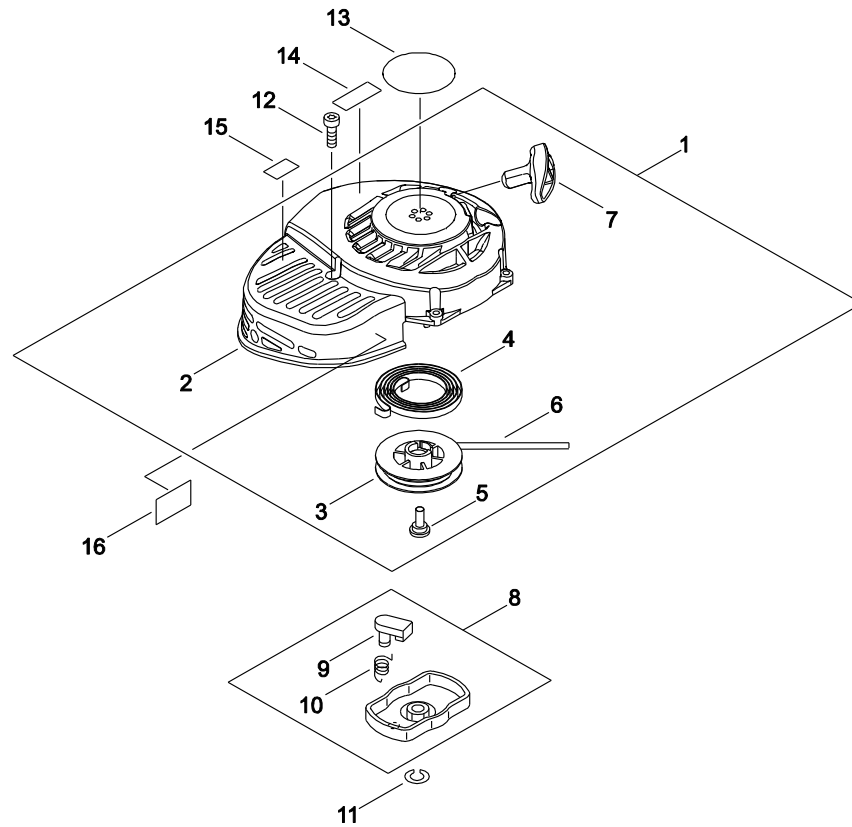

KEY	LV	PART NUMBER	Q'TY	DESCRIPTION	REMARKS	NOTE1	NOTE2
1		A051-002590	1	STARTER,RECOIL ASY			
2	+	P022-039610	1	CASE, STARTER			
3	+	177215-44430	1	DRUM, STARTER			
4	+	177220-42030	1	SPRING, REWIND			
5	+	177236-44330	1	SCREW			
6	+	P022-006231	1	ROPE			
7	+	P022-023170	1	GRIP, STARTER			
8		A052-000160	1	PULLEY,ASM STARTER			
9	+	177218-44330	2	PAWL, STARTER	BLACK		
10	+	177234-12220	2	SPRING, PAWL			
11		900605-00008	1	WASHER, SPRING 8	8		
12		V804-000060	4	BOLT, TORX 4	TB-4*16 10.9		
13		X502-000890	1	LABEL,ECHO			
14		X503-012660	1	LABEL,MODEL			
15		X505-002310	1	LABEL,CAUTION	HOT CAUTION		
16		890123-13360	1	LABEL, CAUTION			

8. HANDLE

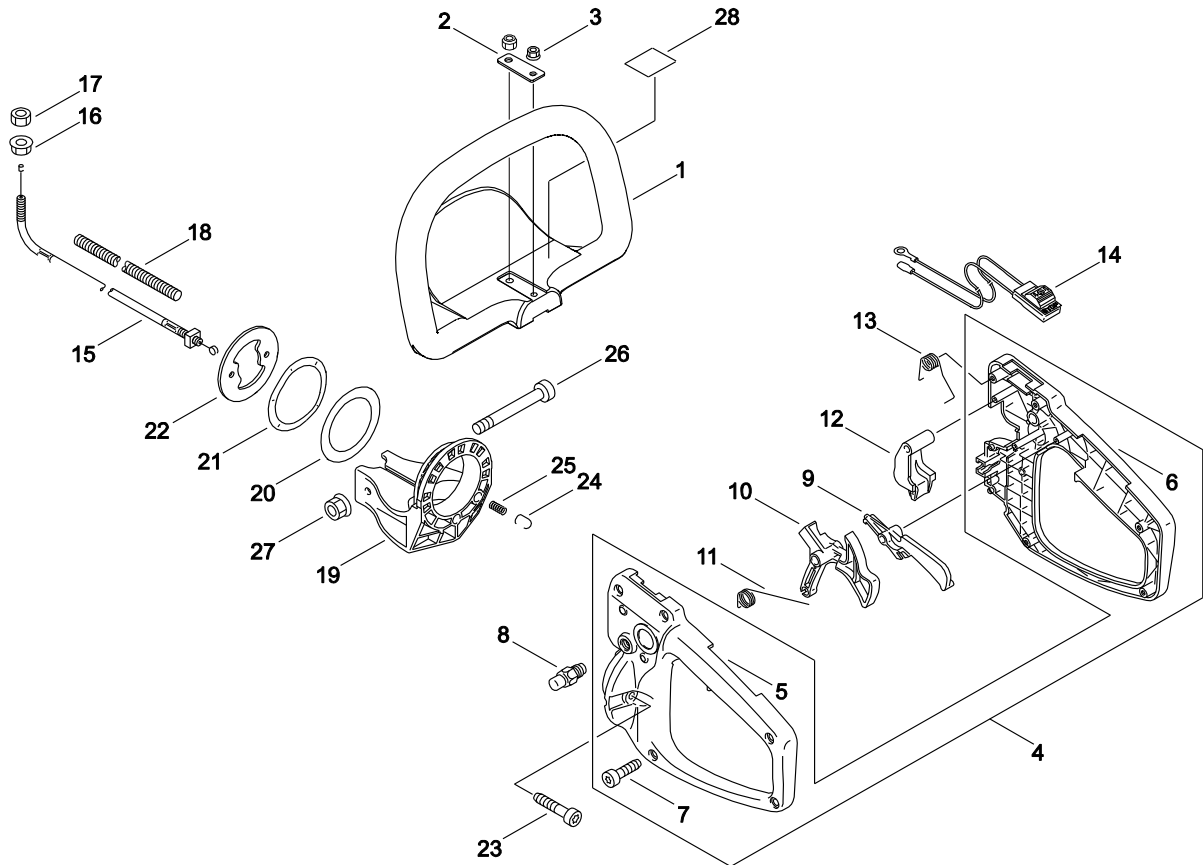

KEY	LV	PART NUMBER	Q'TY	DESCRIPTION	REMARKS	NOTE1	NOTE2
1		C400-000532	1	HANDLE, FRONT	HC155		
2		351611-05360	1	WASHER			
3		92108-05000	1	NUT, FLANGE			
4		P021-045720	1	HANDLE SET, REAR			
5	+	351010-13361	1	HANDLE, REAR			
6	+	351210-13361	1	HANDLE			
7	+	V804-000010	5	BOLT, TORX 4	TT-4*16 DG 10.9		
8		178302-13360	1	LATCH ASY			
9		178012-13360	1	LOCKOUT, THROTTLE			
10		178010-13361	1	TRIGGER, THROTTLE			
11		178013-13660	1	SPRING, TORSION			
12		351648-13360	1	STOPPER, HANDLE			
13		178043-13660	1	SPRING, TORSION			
14		A440-002550	1	SWITCH, ON OFF	LA104 CB104		
15		V430-004680	1	CABLE, BOWDEN			
16		900515-00006	1	NUT, FLANGE 6	6		
17		900502-00006	1	NUT 6 (3N)	3N6		
18		V475-001280	1	TUBE	7*140 コルゲート		
19		351312-13361	1	BRACKET, HANDLE			
20		689025-13361	1	WASHER, CIRCULAR			
21		178129-13361	1	WASHER			
22		351313-13361	1	BRACKET, HANDLE			
23		V805-000050	2	BOLT, TORX 5	TB-5*30 10.9		
24		605611-13360	2	PIN			

8. HANDLE

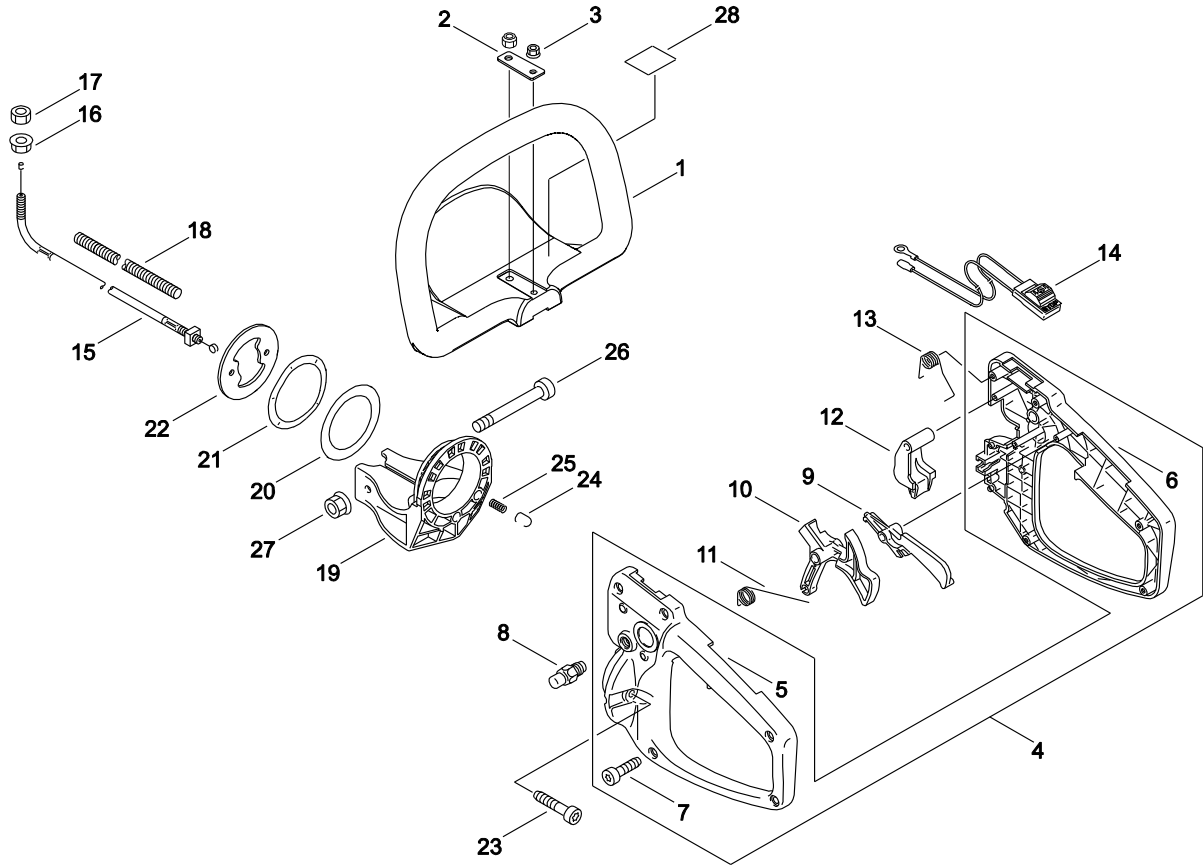

KEY	LV	PART NUMBER	Q'TY	DESCRIPTION	REMARKS	NOTE1	NOTE2
25		178043-13360	2	SPRING			
26		V805-000280	2	BOLT, TORX 5	TB-5*45 10.9		
27		92108-05000	2	NUT, FLANGE			
28		X505-002030	1	LABEL, CAUTION	37*35		

9. ACCESSORIES

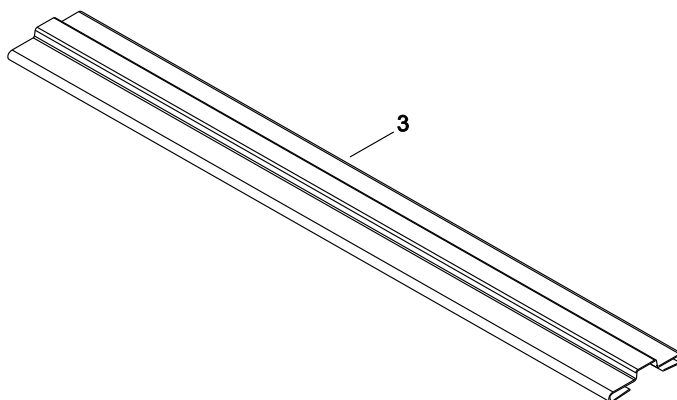
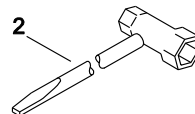
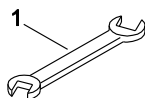

KEY	LV	PART NUMBER	Q'TY	DESCRIPTION	REMARKS	NOTE1	NOTE2
1		895112-00330	1	SPANNER 8*10			
2		895410-03930	1	WRENCH, W/S. DRIVER			
3		X495-000630	1	SCABBARD, BLADE	L585		

10. CARBURETOR

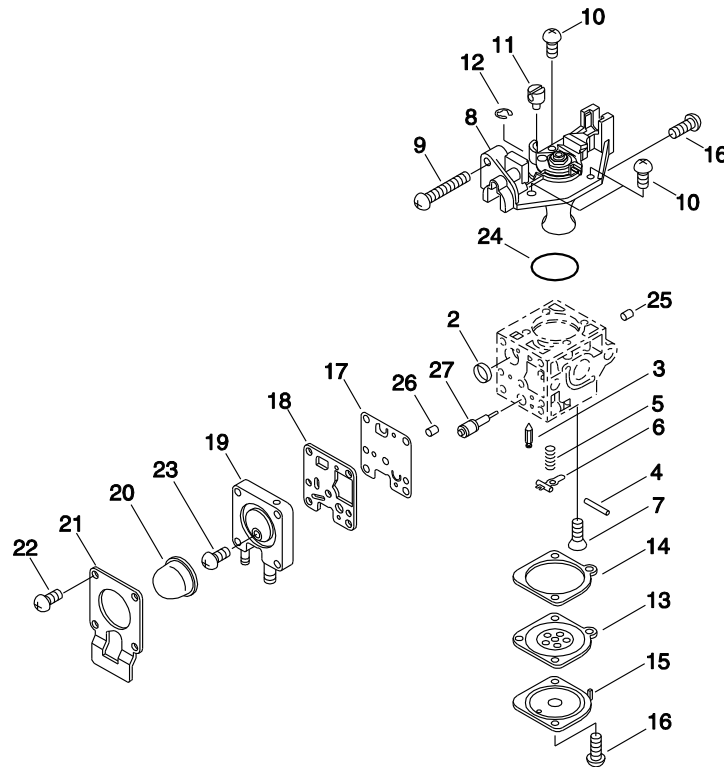

KEY	LV	PART NUMBER	Q'TY	DESCRIPTION	REMARKS	NOTE1	NOTE2
		A021-001673	1	CARBURETOR,DIAPHRAGM			
2	+	P005-000010	1	STRAINER			
3	+	125337-08260	1	VALVE, INLET NEEDLE			
4	+	125338-13930	1	PIN, METERING ARM			
5	+	P005-000940	1	SPRING, METER. LEVER			
6	+	125323-08260	1	ARM, VALVE			
7	+	125339-42030	1	SCREW			
8	+	P005-002050	1	COVER ASY, ROTOR			
9	+	P005-000100	1	SCREW, THROTTLE ADJUST			
10	+	125344-13931	3	SCREW			
11	+	P005-002200	1	POST			
12	+	P005-000190	1	E-RING			
13	+	P005-002230	1	DIAPHRAGM ,METERING			
14	+	P005-000200	1	GASKET, METERING			
15	+	125342-52130	1	COVER, DIAPHRAGM			
16	+	125344-52130	3	SCREW			
17	+	P005-000510	1	DIAPHRAGM, PUMP			
18	+	P005-000520	1	GASKET, PUMP			
19	+	P005-002480	1	BASE ASY,PRIMER			
20	+	P005-003110	1	PUMP, PRIMER			
21	+	P005-000250	1	RETAINER			
22	+	P005-001900	4	SCREW			
23	+	P005-000270	1	SCREW			
24	+	P005-000280	1	O-RING			
25	+	P005-001000	1	ROLLER, GUIDE			

10. CARBURETOR

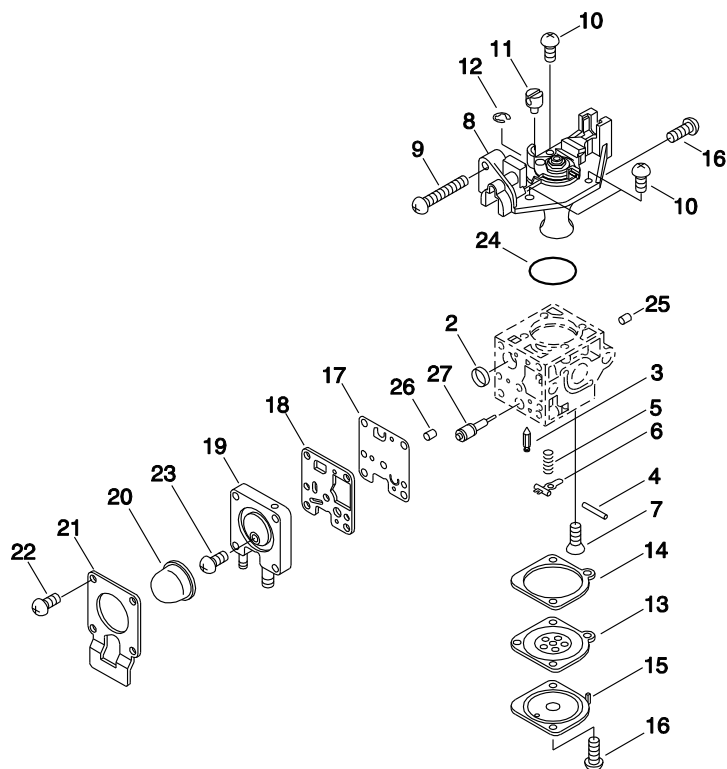

KEY	LV	PART NUMBER	Q'TY	DESCRIPTION	REMARKS	NOTE1	NOTE2
26	+	P005-001250	1	RETAINER,PLUG BALL			
27	+	P005-001260	1	SCREW,MAINN MIXTURE			

Index

Patrs Number	Key No.	Patrs Number	Key No.	Patrs Number	Key No.
100013-11520	2 - 6	610440-04560	1 - 18	A570-000310	3 - 13
100014-08960	2 - 9	689025-13361	8 - 20	C400-000532	8 - 1
100015-04630	2 - 7	699115-05360	1 - 19	C532-000121	1 - 15
100113-05930	2 - 8	880110-10860	1 - 2	P005-000010	10 - 2
100204-11521	2 - 11	890123-13360	7 - 16	P005-000100	10 - 9
100212-42031	2 - 13	890332-52730	4 - 13	P005-000190	10 - 12
100242-42030	2 - 14	895112-00330	9 - 1	P005-000200	10 - 14
125323-08260	10 - 6	895410-03930	9 - 2	P005-000250	10 - 21
125337-08260	10 - 3	900162-05022	2 - 10	P005-000270	10 - 23
125338-13930	10 - 4	900162-05028	2 - 15	P005-000280	10 - 24
125339-42030	10 - 7	900212-05030	1 - 23	P005-000510	10 - 17
125342-52130	10 - 15	900212-06025	1 - 24	P005-000520	10 - 18
125344-13931	10 - 10	900500-00006	1 - 25	P005-000940	10 - 5
125344-52130	10 - 16	900502-00006	8 - 17	P005-001000	10 - 25
129011-52730	4 - 8	900515-00006	8 - 16	P005-001250	10 - 26
130313-05863	4 - 11	900603-00005	5 - 3	P005-001260	10 - 27
131016-55830	5 - 6	900605-00008	7 - 11	P005-001900	10 - 22
131205-07321	5 - 14	900701-00014	1 - 12	P005-002050	10 - 8
131920-61830	5 - 4	900702-00035	1 - 13	P005-002200	10 - 11
132010-40830	5 - 11	900810-36202	1 - 8	P005-002230	10 - 13
132115-46730	5 - 8	900812-06202	1 - 7	P005-002480	10 - 19
145862-40630	6 - 4	92108-05000	8 - 3	P005-003110	10 - 20
175017-44331	3 - 11	92108-05000	8 - 27	P021-004480	4 - 7
177215-44430	7 - 3	94035-36201	2 - 12	P021-007772	2 - 4
177218-44330	7 - 9	A011-000313	2 - 1	P021-012210	5 - 5
177220-42030	7 - 4	A021-001673	4 - 1	P021-045620	1 - 1
177234-12220	7 - 10	A021-001673	10 -	P021-045630	1 - 17
177236-44330	7 - 5	A051-002590	7 - 1	P021-045640	6 - 1
178010-13361	8 - 10	A052-000160	7 - 8	P021-045720	8 - 4
178012-13360	8 - 9	A056-000740	3 - 9	P022-006231	7 - 6
178013-13660	8 - 11	A101-000090	2 - 5	P022-023170	7 - 7
178043-13360	8 - 25	A130-000550	2 - 2	P022-039610	7 - 2
178043-13660	8 - 13	A160-002590	2 - 16	V100-000160	2 - 3
178129-13361	8 - 21	A200-000300	4 - 4	V103-001580	4 - 3
178302-13360	8 - 8	A226-001410	4 - 10	V103-001590	4 - 6
210417-52730	4 - 12	A300-000521	6 - 2	V104-000072	6 - 5
351010-13361	8 - 5	A313-000700	6 - 3	V104-001990	6 - 7
351210-13361	8 - 6	A350-000041	5 - 1	V150-000371	6 - 8
351312-13361	8 - 19	A356-000031	5 - 12	V204-000570	1 - 20
351313-13361	8 - 22	A365-000060	5 - 7	V304-000240	1 - 22
351611-05360	8 - 2	A409-000150	3 - 1	V430-004680	8 - 15
351648-13360	8 - 12	A411-000210	3 - 2	V470-000580	5 - 9
433022-06460	1 - 21	A425-000000	3 - 6	V471-001200	5 - 10
605611-13360	8 - 24	A426-000010	3 - 8	V475-001280	8 - 18
610312-04560	1 - 6	A427-000013	3 - 7	V475-007510	3 - 3
610350-04560	1 - 11	A440-002550	8 - 14	V485-000870	3 - 4
610411-05361	1 - 3	A552-000380	3 - 12	V490-001100	4 - 2
610414-05360	1 - 4	A556-001620	1 - 5	V490-001240	5 - 13
610425-04560	1 - 14	A566-000000	3 - 10	V490-001240	5 - 15

Index

Patrs Number	Key No.	Patrs Number	Key No.	Patrs Number	Key No.
V804-000010	2 - 17				
V804-000010	8 - 7				
V804-000030	6 - 6				
V804-000040	1 - 9				
V804-000060	3 - 14				
V804-000060	7 - 12				
V804-000070	3 - 5				
V805-000000	5 - 2				
V805-000050	8 - 23				
V805-000100	4 - 9				
V805-000150	2 - 18				
V805-000170	4 - 5				
V805-000190	6 - 9				
V805-000280	8 - 26				
V806-000130	1 - 10				
X412-000630	1 - 16				
X495-000630	9 - 3				
X502-000890	7 - 13				
X503-012660	7 - 14				
X505-002030	8 - 28				
X505-002310	7 - 15				

YAMABIKO CORPORATION

7-2 SUEHIROCHO 1-CHOME, OHME, TOKYO 198-8760, JAPAN
PHONE: 81-428-32-6118. FAX: 81-428-32-6145.



-15B
No. 06-113