

CHAIN SAW

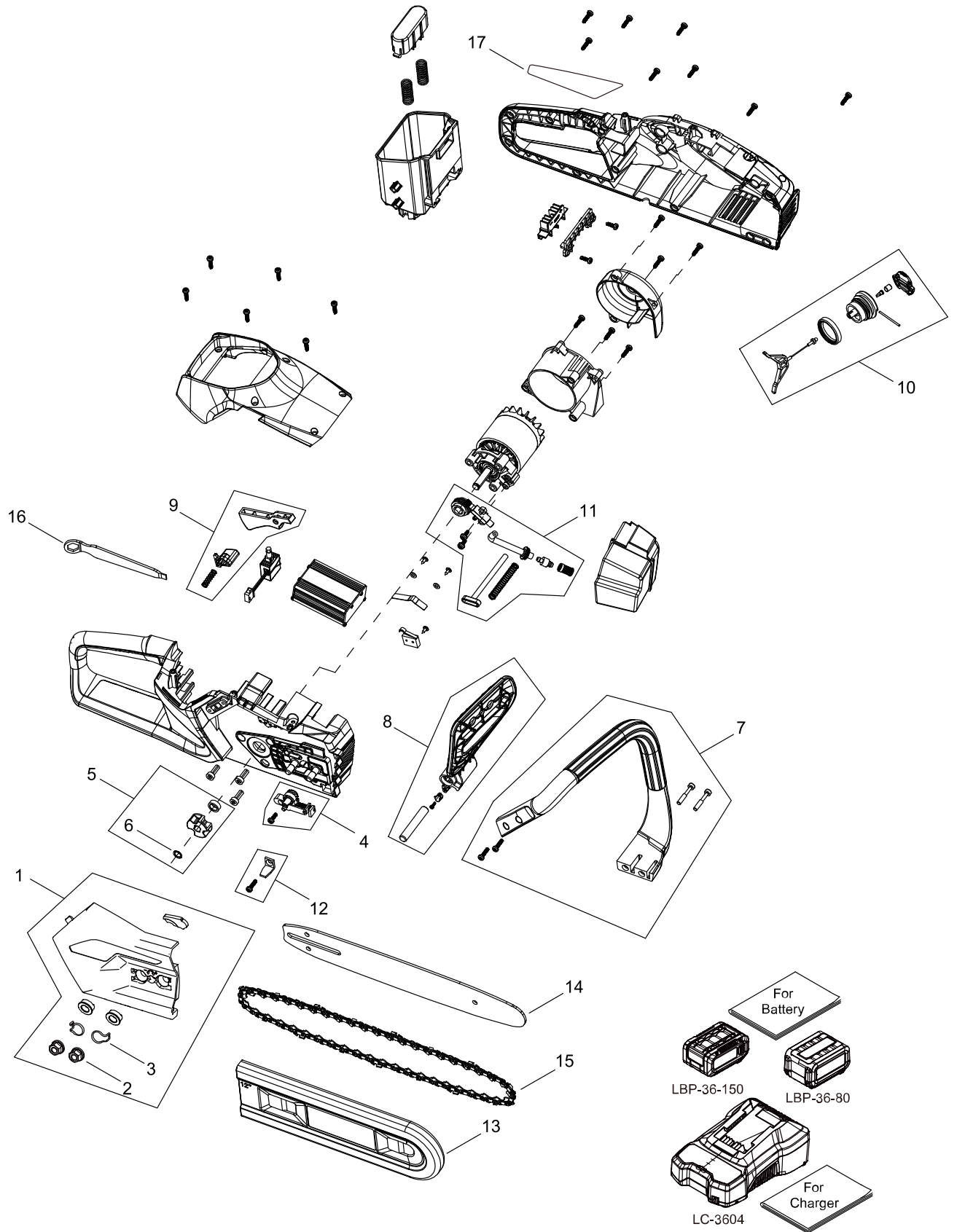

* Batteries and charger are handled as accessories instead of spare parts. Please place an order of batteries and charger at the same time as unit order.

CHAIN SAW

Key No.	LV (+)	Parts Number	Parts Description	Qty	Standard	Class
1		P022-061530	GUARD, SPROCKET ASY	1		C
2	+	V265-000550	NUT,8	2		C
3	+	C649-000420	HOOK	2		D
4		P022-061550	TENSIONER, CHAIN	1		C
5		P022-061560	SPROCKET	1		B
6	+	P022-062180	RETAINING RING	1		C
7		P022-061570	HANDLE, FRONT	1		C
8		P022-061580	LEVER, BRAKE	1		C
9		P022-061590	LEVER	1		C
10		P022-061600	OIL CAP ASY	1		C
11		P022-061610	AUTO-OILER ASY	1		C
12		P022-061620	CATCHER, CHAIN	1		B
13		P022-061630	SCABBARD,CHAIN	1		D
14		X122-000520	BAR,GUIDE 30	1	12A4CD3745	A
15		X222-000150	CHAIN,SAW	1	90PX-45E 43	A
16		P022-061640	TOOL,WRENCH	1		D
17		P022-061650	LABEL,CAUTION	1		D

Class : Consumable class

A:Fast moving parts B:Semi-fast moving parts C:Slow moving parts D:Order only as needed