

RV140 割草机动力图册

FIG.1 HEAD SUBASSEMBLY, CYLINDER / PLUG, SPARK 气缸头部件/火花塞 (E01)

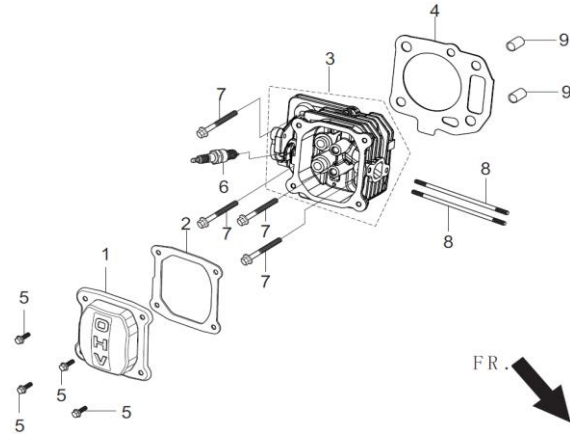

REF.NO. 序号	PART NO 物料代码	CHINSES 中文名	DESCRIPTION 英文名	Q'TY 数量	包装数	备注
E01-1	12411-Z030120-0000	气缸头盖	COVER, CYLINDER HEAD	1	1	
E01-2	12004-Z030110-0000	气缸头盖密封垫	GASKET, CYLINDER HEAD COVER	1	1	
E01-3	12140-Z250210-0000	气缸头组合	HEAD SUBASSEMBLY, CYLINDER	1	1	
E01-4	12131HZ250130-0000	气缸头密封垫	GASKET, CYLINDER HEAD	1	1	
E01-5	90007-0612-A1	六角法兰面螺栓-加大系列-B级	BOLT	4	1	
E01-6	30010-Z010110-0000	火花塞	PLUG, SPARK	1	1	
E01-7	12003-Z030110-0000	气缸头螺栓	BOLT, CYLINDER HEAD	4	1	
E01-8	90204-Z250310-0000	双头螺柱 bm=2d	STUD	2	1	
E01-9	90502-1014-00	定位销-A型	PIN	2	1	

FIG.2 CRANKCASE. 曲轴箱组件(E02)

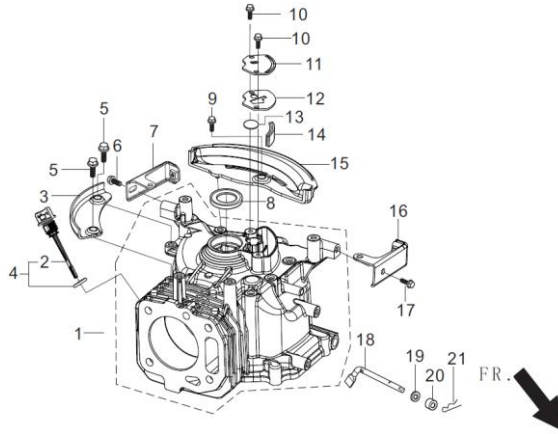

REF.NO. 序号	PART NO 物料代码	CHINSES 中文名	DESCRIPTION 英文名	Q'TY 数量	包装数	备注
E02-1	11310-Z250170-0000	曲轴箱体组合	CRANKCASE SUBASSEMBLY.	1	1	
E02-3	19308HZ250120-0000	箱体左侧护罩	SHIELD, CRANKCASE SIDE	1	1	
E02-4	15010-Z030120-Q500	机油尺组合	DIPSTICK SUBASSEMBLY, OIL	1	1	
E02-5	90001-0514-01	六角法兰面螺栓-小系列-A级	BOLT	2	1	
E02-6	90007-0612-A1	六角法兰面螺栓-加大系列-B级	BOLT	1	1	
E02-7	16608HZ030120-0000	油箱安装右支架	BRACKET, FUEL TANK RIGHT	1	1	
E02-8	90682-Z250110-0000	油封	SEAL, OIL	1	1	
E02-9	90001-0514-01	六角法兰面螺栓-小系列-A级	BOLT	1	1	
E02-10	90007-0612-A1	六角法兰面螺栓-加大系列-B级	BOLT	2	1	
E02-11	11333-Z250210-0000	呼吸槽盖板	PLATE, BREATH GROOVE COVER	1	1	
E02-12	11332-Z250410-0000	呼吸槽密封垫	GASKET, BREATH GROOVE	1	1	
E02-13	11321-Z030110-0099	呼吸片	PIECE, BREATH	1	1	
E02-14	11331-Z250110-0000	呼吸槽滤网	STRAINER, BREATH GROOVE	1	1	
E02-15	19351-Z250110-0000	箱体后护罩	SHIELD, CRANKCASE REAR	1	1	
E02-16	16607HZ250110-0000	油箱安装左支架	BRACKET, FUEL TANK LEFT	1	1	
E02-17	90007-0612-A1	六角法兰面螺栓-加大系列-B级	BOLT	1	1	
E02-18	16061-Z250120-0000	调速臂	ARM, GOVERNOR	1	1	
E02-19	90408-Z010210-0000	平垫圈 A级	WASHER	1	1	
E02-20	90682-Z030210-0000	油封	SEAL, OIL	1	1	
E02-21	90501-Z010110-0000	开口销	PIN	1	1	

FIG.3 COVER SUBASSEMBLY, CRANKCASE / GEAR ASSY, GOVERNOR 曲轴箱盖部件 + 调速齿轮部件(E03)

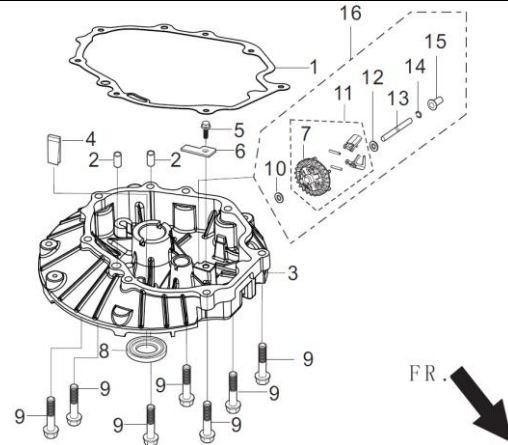

REF.NO. 序号	PART NO 物料代码	CHINSES 中文名	DESCRIPTION 英文名	Q'TY 数量	包装数	备注
E03-1	11001-Z250610-0000	曲轴箱密封垫	GASKET, CRANKCASE	1	1	
E03-2	90502-0812-00	定位销-A型	PIN	2	1	
E03-3	11411-Z250120-0000	曲轴箱盖	COVER, CRANKCASE	1	1	
E03-4	11341-Z030110-0000	回油块	BLOCK, RETURNING OIL	1	1	
E03-5	90007-0612-A1	六角法兰面螺栓-加大系列-B级	BOLT	1	1	
E03-6	16013-Z030120-0000	调速芯轴压板	PLATE, GOVERNOR SPINDLE COMPRESSION	1	1	
E03-8	90682-Z030120-0000	油封	SEAL, OIL	1	1	
E03-9	90007-0628-A1	六角法兰面螺栓-加大系列-B级	BOLT	7	1	
E03-16	16400-Z250110-0000	调速齿轮部件	GEAR ASSY, GOVERNOR	1	1	

FIG.4 ROD,CRANKSHAFT CONNETING 曲柄连杆组件(E04)

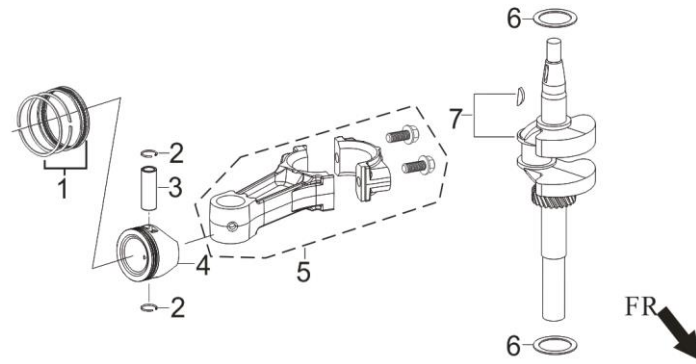

REF.NO. 序号	PART NO 物料代码	CHINSES 中文名	DESCRIPTION 英文名	Q'TY 数量	包装数	备注
E04-1	13200-Z250110-0000	活塞环部件	RING ASSY, PISTON	1	1	
E04-2	13122-Z250110-0000	活塞销卡圈	CLIP, PISTON PIN	2	1	
E04-3	13121-Z250110-0000	活塞销	PIN, PISTON	1	1	
E04-4	13111-Z250120-0000	活塞	PISTON	1	1	
E04-5	13010-Z250110-0000	连杆	ROD, CONNECTING	1	1	
E04-6	90408-Z030210-0000	平垫圈-A级	WASHER	2	1	
E04-7	13300-Z250320-0000	曲轴部件	CRANKSHAFT ASSY.	1	1	

FIG.5 TRAIN,VALVE / CAMSHAFT SUBASSEMBLY 配气机构组件/凸轮轴 (E05)

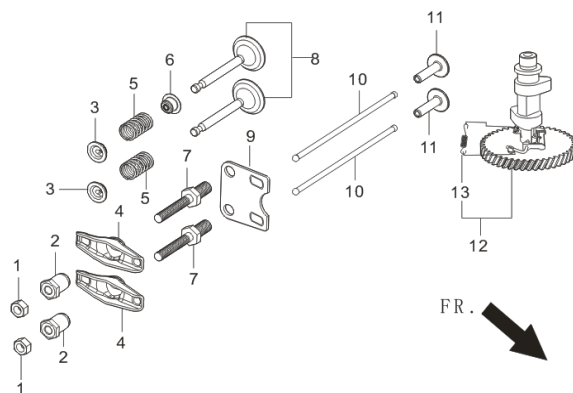

REF.NO. 序号	PART NO 物料代码	CHINSES 中文名	DESCRIPTION 英文名	Q'TY 数量	包装数	备注
E05-1	14312-Z010110-0000	气门锁紧螺母	NUT, VALVE LOCK	2	1	
E05-2	14314-Z010110-0000	气门调节螺母	NUT , VALVE ADJUSTING	2	1	
E05-3	12112-Z010110-0000	气门弹簧座	SEAT, VALVE SPRING	2	1	
E05-4	14311-Z010110-0000	气门摇臂	ROCKER, VALVE	2	1	
E05-5	12103-Z030110-0000	气门弹簧	SPRING, VALVE	2	1	
E05-6	12101-Z030110-0000	挡油罩	GUIDE, SEAL	1	1	
E05-7	14313-Z010110-0000	摇臂轴螺栓	BOLT, VALVE ADJUSTING	2	1	
E05-8	12110-Z250110-0000	气门组件	VALVE	1	1	
E05-9	14091-Z250410-0000	挺杆限位板	PLATE SUBASSEMBLY, LIFTER STOPPER	1	1	
E05-10	14071-Z250110-0000	气门挺杆	LIFTER, VALVE	2	1	
E05-11	14081-Z010110-0000	气门挺柱	TAPPET, VALVE	2	1	
E05-12	14200-Z250210-0000	凸轮轴部件	CAMSHAFT ASSY.	1	1	

FIG.6 STARTER,RECOIL 手起动组件 (E06)

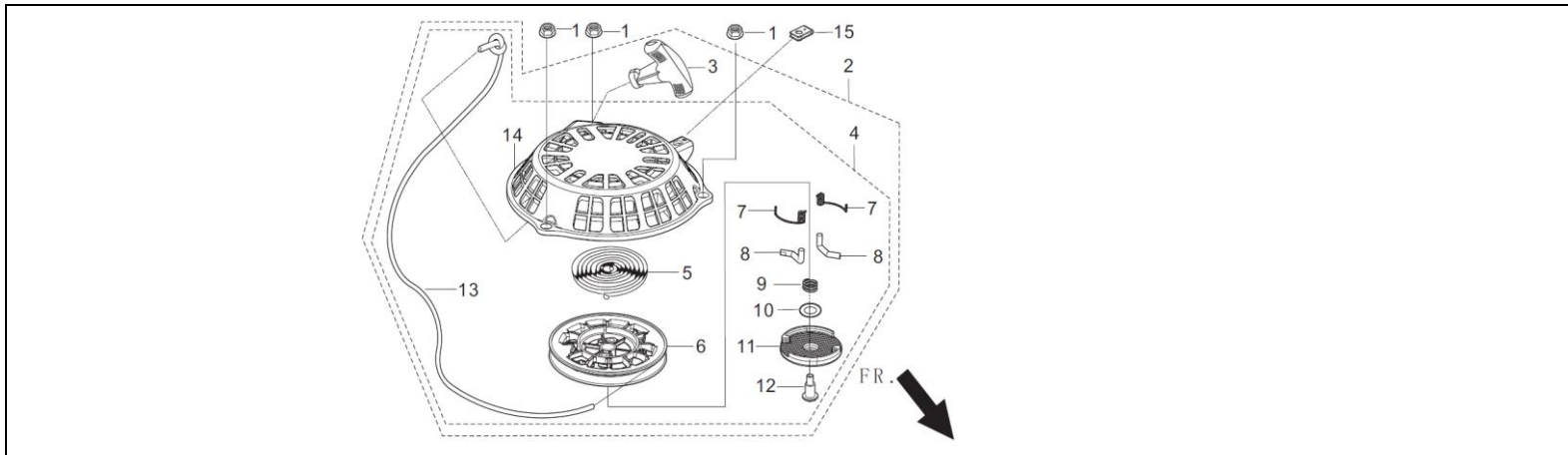

REF.NO. 序号	PART NO 物料代码	CHINSES 中文名	DESCRIPTION 英文名	Q'TY 数量	包装数	备注
E06-1	90305-0600-31	六角法兰面螺母	NUT	3	1	
E06-2	28200-Z250610-Q200	手起动部件	STARTER ASSY, RECOIL	1	1	
E06-15	28201-Z030110-0001	拉绳盘罩卡子	CLIP , CABLE COVER	1	1	

FIG.7 SHIELD,FAN 导流罩 (E07)

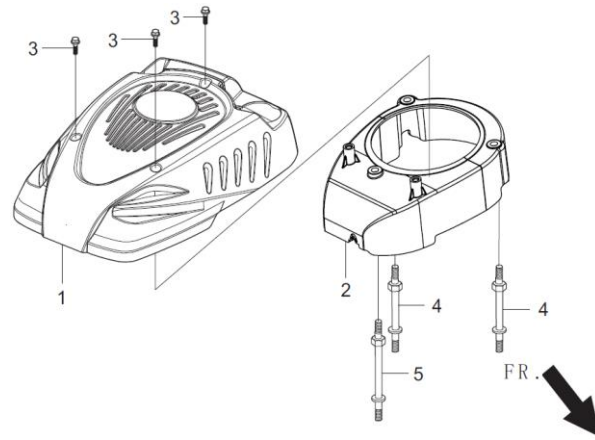

REF.NO. 序号	PART NO 物料代码	CHINSES 中文名	DESCRIPTION 英文名	Q'TY 数量	包装数	备注
E07-1	80001-Z030410-Q200	发动机外罩	HOUSING, ENGINE	1	1	
E07-2	28110-Z250210-Q200	导风罩	SHROUD	1	1	
E07-3	90001-0525-0331	六角法兰面螺栓-小系列	BOLT	3	1	
E07-4	28001-Z030110-0000	双头支撑螺栓	STUD	2	1	
E07-5	28001-Z470110-0000	双头支撑螺栓	STUD	1	1	

FIG.8 CARBURETOR ASSY. 化油器部件 (E08)

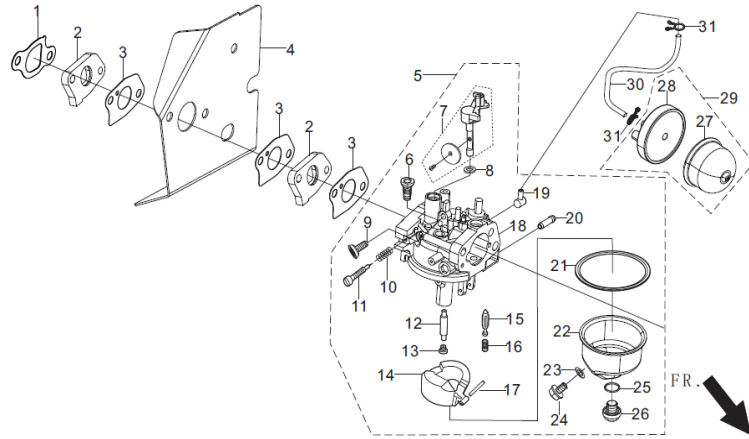

REF.NO. 序号	PART NO 物料代码	CHINSES 中文名	DESCRIPTION 英文名	Q'TY 数量	包装数	备注
E08-1	16004-Z250110-0000	隔热板密封垫	GASKET, INSULATOR PLATE	1	1	
E08-2	16003-Z250210-0000	化油器隔热板	PLATE, CARBURETOR INSULATOR	2	1	
E08-3	16001-Z010110-0000	化油器密封垫	GASKET, CARBURETOR	3	1	
E08-4	16002-Z250110-0000	化油器隔热垫	GASKET, CARBURETOR INSULATOR	1	1	
E08-5	16100-Z250320-0000	化油器部件	CARBURETOR ASSY.	1	1	
E08-29	16210-Z250120-0030	起动加浓阀	VALVE, STARTING RICHED	1	1	
E08-30	16211-Z250110-0000	起动加浓阀管	TUBE, STARTING RICHED VALVE	1	1	
E08-31	90685-0700-01	卡箍	COLLAR	2	1	

FIG.9 CLEANER, AIR 空滤器 (E09)

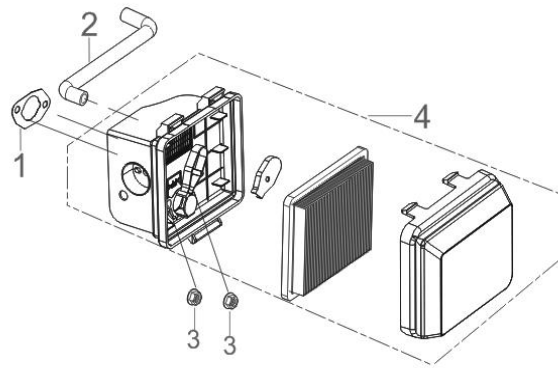

REF.NO. 序号	PART NO 物料代码	CHINSES 中文名	DESCRIPTION 英文名	Q'TY 数量	包装数	备注
E09-1	17001-Z250310-0000	空滤器密封垫	GASKET, AIR CLEANER	1	1	
E09-2	17004-Z250310-0000	废气管	TUBE, BREATHER	1	1	
0	17150-Z030110-0000		AIR, CLEANER FILTER	1	1	
E09-3	90305-0600-31	六角法兰面螺母	NUT	2	1	
E09-4	17100-Z250410-0000	空滤器	CLEANER, AIR	1	1	

FIG.10 MUFFLER 消声器 (E10)

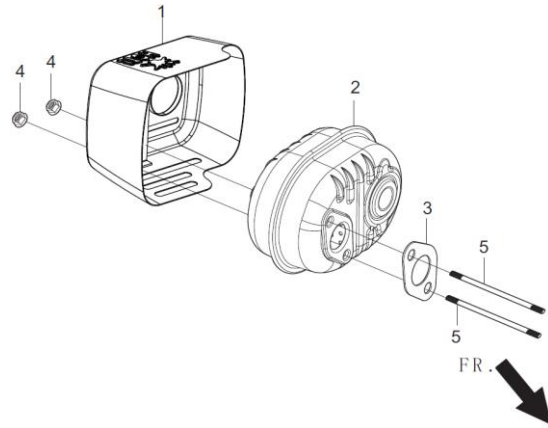

REF.NO. 序号	PART NO 物料代码	CHINSES 中文名	DESCRIPTION 英文名	Q'TY 数量	包装数	备注
E10-1	18130-Z250410-QA00	消声器外罩	COVER, MUFFLER OUTER	1	1	
E10-2	18100-Z030110-QA00	消声器部件	MUFFLER ASSY.	1	1	
E10-3	18001-Z250210-0000	排气口密封垫	GASKET, EXHAUST OUTLET	1	1	
E10-4	90305-0600-31	六角法兰面螺母	NUT	2	1	
E10-5	90204-Z250110-0000	双头螺柱bm=2d	STUD	2	1	

FIG.11 TANK, FUEL 油箱 (E11)

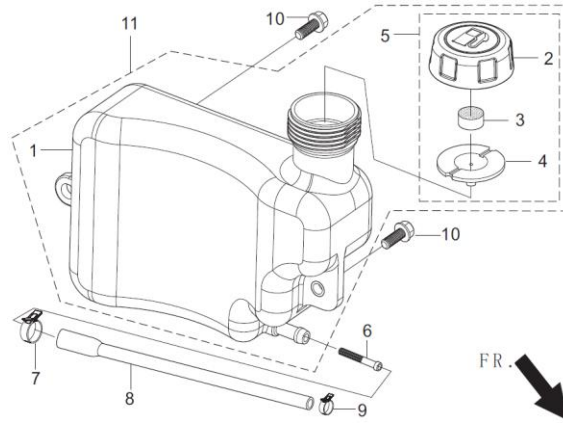

REF.NO. 序号	PART NO 物料代码	CHINSES 中文名	DESCRIPTION 英文名	Q'TY 数量	包装数	备注
E11-6	16652-Z030110-0000	燃油滤网	STRAINER , FUEL	1	1	
E11-7	90685-Z030110-0000	管夹	CLAMP	1	1	
E11-8	90686-Z250110-0000	油管	TUBE, FUEL	1	1	
E11-9	90685-0700-01	管夹	CLAMP	1	1	
E11-10	90007-0614-A1	六角法兰面螺栓-加大系列-B级	BOLT	2	1	
E11-11	16600-Z030110-Q200	油箱部件	TANK ASSY, FUEL	1	1	

FIG.13 CONTROL ASSY, THROTTLE 油门操纵部件 (E13)

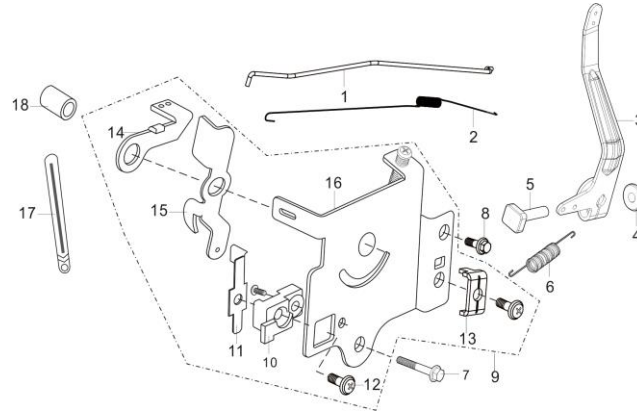

REF.NO. 序号	PART NO 物料代码	CHINSES 中文名	DESCRIPTION 英文名	Q'TY 数量	包装数	备注
E13-1	16062-Z250110-0000	调速拉杆	ROD, GOVERNEOR	1	1	
E13-2	16012-Z030120-0000	节气门复位弹簧	SPRING, THROTTLE VALVE RETURNING	1	1	
E13-3	16070-Z250110-0000	调速支架组合	SUPPORT SUBASSEMBLY, GOVERNOR	1	1	
E13-4	90305-0600-31	六角法兰面螺母	NUT	1	1	
E13-5	16072-Z010110-0000	调速支架固定螺栓	BOLT, GOVERNOR SUPPORT	1	1	
E13-6	16063-Z030120-0000	调速弹簧	SPRING, GOVERNOR	1	1	
E13-7	90007-0655-A1	六角法兰面螺栓-加大系列-B级	BOLT	1	1	
E13-8	90007-0635-A1	六角法兰面螺栓-加大系列-B级	BOLT	1	1	
E13-9	16520-Z250910-0000	油门操纵组合	CONTROL ASSY, THROTTLE	1	1	
E13-17	90684-Z030120-0000	线夹	CLIP	1	1	