

输入 59000

标题

CAD

全套

视图

标注

比例

日期

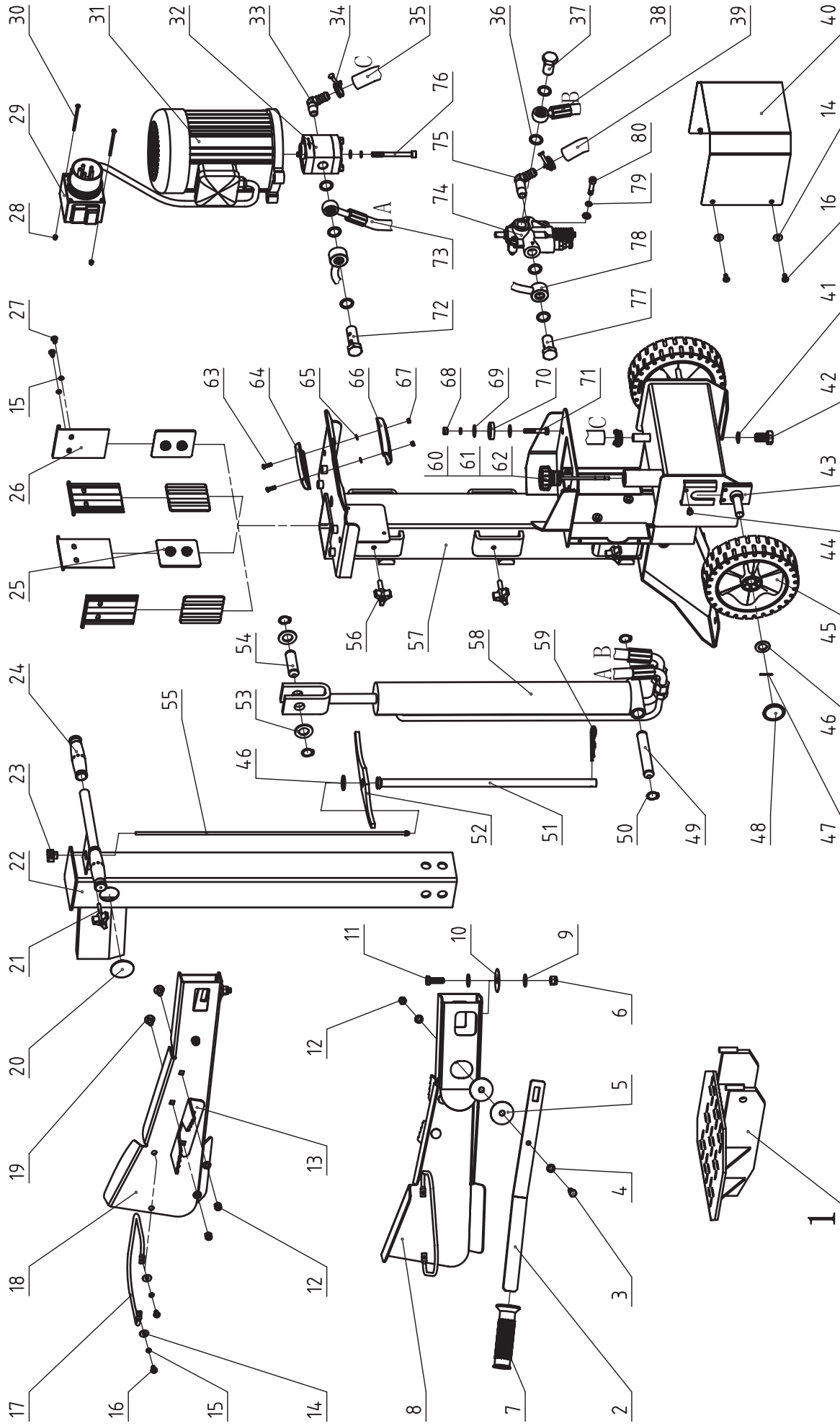

三相 400V		爆炸图		CCG5立劈	
图样名称	重量	比例	日期	共	张
S   B		1:5.5			
设计	审核	日期	2013-2-26		
校对	工艺				
制图					
审核					
批准					

自信机械(莱州)有限公司

## C108爆炸图零件明细

No.	Description	Qty
1	Work Table G5	1
2	Operate Handle G3	2
3	Bolt 8.8 M8*30	2
4	Washer 8	12
5	Washer K	6
6	Locknut M10	2
7	Handle Sleeve K	2
8	Right Guard Assy.	1
9	Big Washer 10	4
10	Washer L	2
11	Bolt 8.8 M10*30	2
12	Locknut M8	6
13	Clamping Fork K	2
14	Big Washer 6	8
15	Spring Washer 6	12
16	Cross Recess Head Screw M6X12	8
17	Guard Circle G5	2
18	Left Guard Assy.	1
19	Cup Head Square Neck Bolt M8x16	4
20	Plug for Cutting Tube	2
21	Star Knob M6	1
22	Wedge Bracket Weldment	1
23	Nut M5(black)	1
24	Handle Sleeve	2
25	Lower Plastic Insert G	4
26	Lower Plastic Insert G1	4
27	Cross Recess Head Screw M6X8	8
28	Locknut M4	2
29	Switch CCA1	1
30	Cross Recess Head Screw M4X60	2
31	Motor, 3 Phase	1
32	Gear Pump	1
33	Square Nozzle H	1
34	Hose Clamp 20-26	4
35	Intake Hose 16	0,15
36	Washer Groupware 20	7
37	Valve Plug G1	1
38	High Pressure Oil Hose G5	1
39	Oil Return Hose 16	0,14
40	Pump Cover G5	1
41	Washer Groupware 16	1
42	Bolt M16X25	1
43	Wheel Axle G5	2
44	Bolt 8.8 M6X8	2
45	Wheel	2
46	Washer 16	1
47	Cotter Pin 2x20	2
48	Wheel Cover	2
49	Long Shaft G	1
50	Circlip 20	4
51	Draw Pipe KG	1
52	Lever G5	1

## C108爆炸图零件明细

53	Washer 20	2
54	Short Shaft G	1
55	Draw Rod G5	1
56	Star Knob	3
57	Upright Tube Weldment G5	1
58	Cylinder G5	1
59	Clip 4	1
60	Nozzle Cover Z	1
61	O-Ring 25x2.65	2
62	Dipstick k6	1
63	Cross Recess Head Screw M5X16	2
64	Upper Handle Sleeve	1
65	Washer 5	2
66	Lower Handle Sleeve	1
67	Nut M5	2
68	Nut M6	3
69	Big Washer 8	6
70	Motor Foot	3
71	Bolt 8.8 M8X40	3
72	Plug G5	1
73	Working Oil Hose G5	1
74	Valve	1
75	Square Nozzle A4	1
76	Hexagonal Socket Head Cap Screw M8X8	2
77	Short Plug A2	1
78	Differential Oil Hose C1	1
79	Spring Washer 8	7
80	Hexagonal Socket Head Cap Screw M8X3	2