

CS-8002

Serial Number

36001406-36004000

Last updated date

09/Jan/2023

TABLE OF CONTENTS

CYLINDER, CRANKCASE, PISTON	1
AIR CLEANER, CARBURETOR, MUFFLER	5
STARTER, MAGNETO	7
HANDLE.....	9
CLUTCH, SPROCKET	11
AUTO-OILER.....	13
CHAIN BRAKE ASSEMBLY.....	15
CARBURETOR.....	17

CYLINDER, CRANKCASE, PISTON

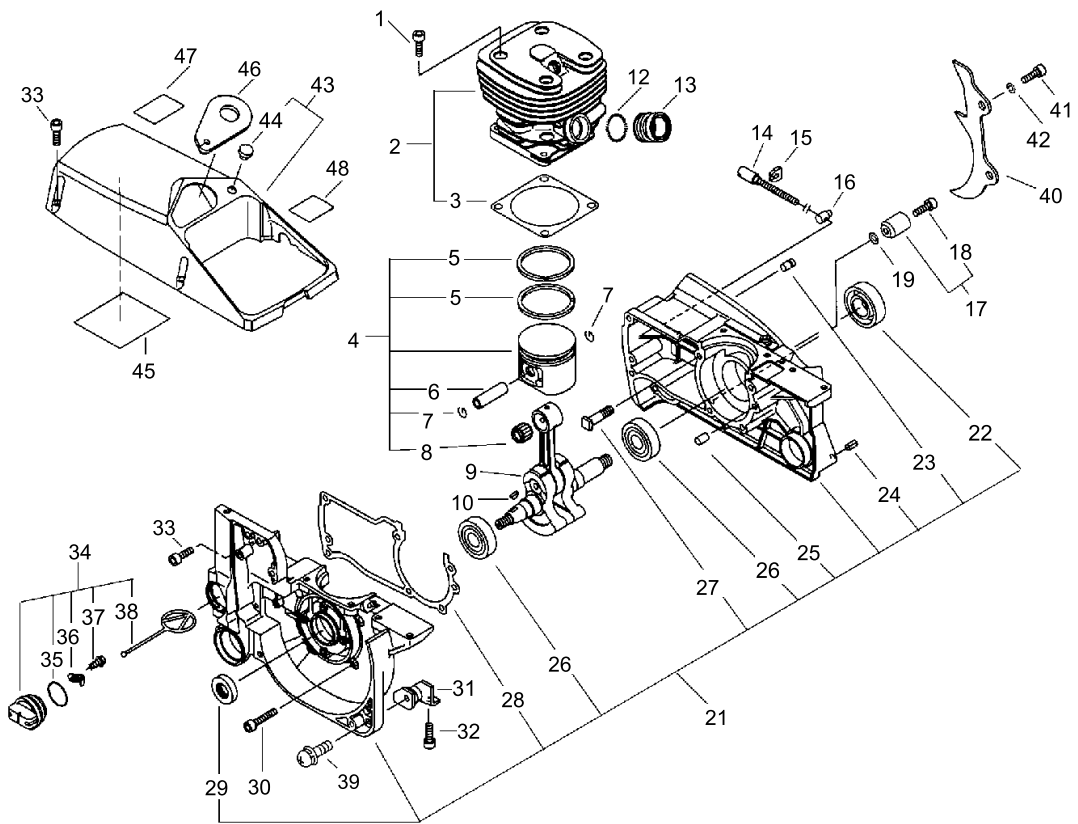

CYLINDER, CRANKCASE, PISTON

Key No.	LV (+)	Parts Number	Parts Description	Qty	Standard	Class
1		900162-06025	BOLT, H.S. 6*25	4	6*25 W,SW	
2		P021-005410	CYLINDER ASY	1		
3	+	101010-30830	GASKET, CYL. BASE	1		B
4		P021-005420	PISTON KIT	1		
5	+	100011-30831	RING, PISTON	2		B
6	+	V611-000000	PIN,ENG 13	1	8*13*38.8	D
7	+	100015-30830	CIRCLIP, PISTON PIN	2		C
8	+	100012-30830	BEARING, NEEDLE	1		C
9		100100-30830	CRANKSHAFT ASSY	1		D
10		100142-30830	KEY, WOODRUFF	1		C
12		130516-30830	BAND	1		B
13		130510-30830	ADAPTER, INTAKE	1		C
14		433016-11031	SCREW, TENSIONER	1		C
15		433028-11030	CLIP	1		D
16		433014-02830	TENSIONER	1		C
17		P021-014070	CHAIN CATCHER KIT	1		
18	+	900162-05020	BOLT, H.S. 5*20	1	5*20 W,SW	
19		900600-00005	WASHER 5	1	5	
21		100204-30832	CRANKCASE KIT	1		
22	+	100213-30830	OILSEAL	1	25Z-16 39.9 7	C
23	+	436114-13930	VALVE, CHECK	1		B
24	+	900345-50010	PIN, SPRING 5*10SUS	1	5*10SUS	
25	+	100215-02830	PIN, DOWEL	2		C
26	+	900810-36203	BEARING, BALL 6203	2	6203/C3	
27	+	433011-19830	STUD, GUIDE BAR	2		C
28	+	100242-30830	GASKET, CRANKCASE	1		B
29	+	100212-19830	OILSEAL	1	ISM 15*25*6	C
30		900162-05035	BOLT, H.S. 5*35	4	5*35 W,SW	
31		100921-30830	CUSHION	1		B
32		900162-05014	BOLT, H.S. 5*14	1	5*14 W,SW	
33		900162-05020	BOLT, H.S. 5*20	5	5*20 W,SW	
34		436001-31730	CAP ASSY, OIL TANK	1		
35	+	900721-00025	O-RING 25	1	G-25	
36	+	131050-19830	RETAINER, LINK	2		C
37	+	900246-03008	SCREW 3*8	1	3*8	
38	+	131051-19830	LINK	1	60L	B
39		900238-05014	SCREW 5*14	1	5*14	
40		880210-30830	BUMPER, SPIKED	1		C
41		900105-06020	BOLT, H.S. 6*20	2	6*20	
42		900605-00006	SPRING WASHER	2	6	
43		101501-31730	COVER, CYLINDER	1		
44	+	101578-30830	PLUG	1		B
45		101520-33330	COVER	1		C
46		101541-30831	PLATE, GUIDE	1		C

Class : Consumable class

A:Fast moving parts B:Semi-fast moving parts C:Slow moving parts D:Order only as needed

CYLINDER, CRANKCASE, PISTON

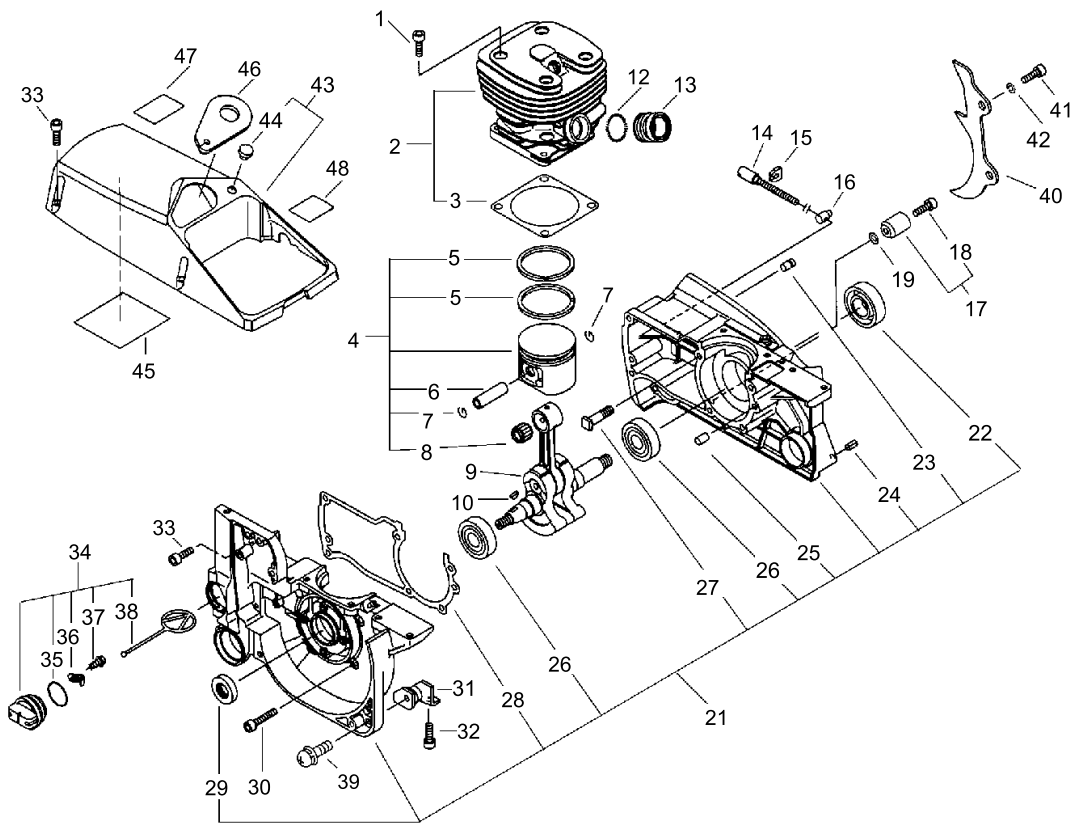

CYLINDER, CRANKCASE, PISTON

Key No.	LV (+)	Parts Number	Parts Description	Qty	Standard	Class
47		890345-39230	LABEL, CAUTION	1		D
48		890631-38130	LABEL, CAUTION	1		D

Class : Consumable class

A:Fast moving parts B:Semi-fast moving parts C:Slow moving parts D:Order only as needed

AIR CLEANER, CARBURETOR, MUFFLER

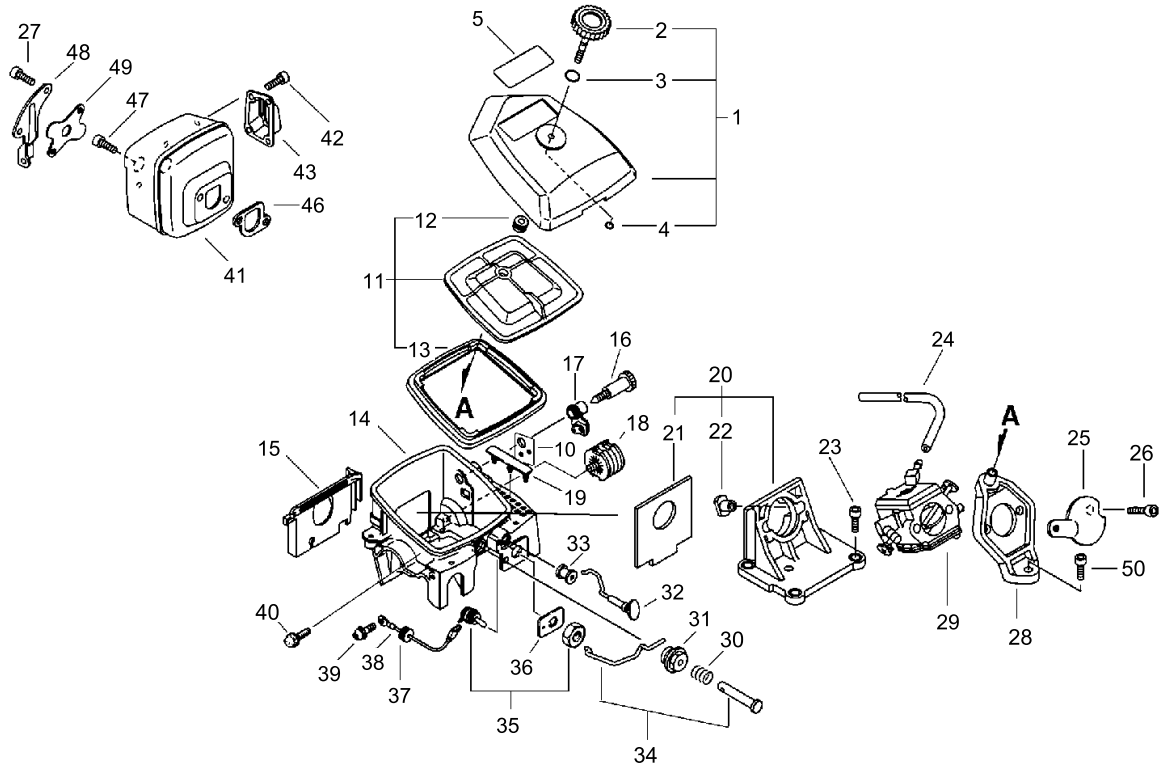

AIR CLEANER, CARBURETOR, MUFFLER

Key No.	LV (+)	Parts Number	Parts Description	Qty	Standard	Class
1		130302-30830	COVER SET, AIR CLN	1		
2	+	130406-30830	NUT, THUMB	1		C
3	+	900720-00010	O-RING P-10	1	P-10	
4	+	900720-00003	O-RING P-3	1	P-3	
5		X503-009160	LABEL,MODEL	1	CS-8002 EU	D
10		890169-60830	LABEL, ADJUSTING	1		D
11		130303-30831	FILTER, AIR W/SEAL	1		
12	+	130356-19830	GROMMET	1		C
13	+	130320-30831	SEAL, CLEANER	1		A
14		130306-30830	CASE, CARBURETOR(BS)	1		C
15		101529-30830	PLATE, GUIDE (A)	1		C
16		129013-30831	SCREW, IDLE SPEED	1		D
17		129010-38830	GROMMET, NEEDLE	1		C
18		100905-19830	CUSHION	1		B
19		130339-30830	PLUG	1		C
20		130007-30830	INSULATOR	1		
21	+	130012-30830	SEAL, DUST	1		C
22	+	130020-19830	NUT	2		C
23		900162-05025	BOLT, H.S. 5*25	4	5*25 W,SW	
24		130110-30830	PIPE, IMPULSE	1		C
25		129011-19831	PLATE	1		C
26		900162-05055	BOLT, H.S. 5*55	2	5*55 W,SW	
27		900162-05014	BOLT, H.S. 5*14	2	5*14 W,SW	
28		130405-30830	SUPPORTER, FILTER	1		C
29		123000-38832	CARBURETOR HDA-153B	1	HDA-153B	B
30		178078-19830	SPRING	1		B
31		178114-19830	HOLDER, THR. LEVER	1		C
32		178510-30830	ROD, CHOKE	1		C
33		178810-11231	GROMMET	1		C
34		178307-30830	ROD, THROTTLE	1		
35		163400-30830	SWITCH, IGNITION	1		C
36		890157-19830	LABEL, SWITCH	1		D
37		156114-04920	GROMMET	2		C
38		162021-30830	LEAD	1		C
39		900242-04008	SCREW	1	4*8	
40		900220-04008	SCREW 4*8	1	4*8	
41		145610-30830	MUFFLER	1		C
42		900162-04010	BOLT, H.S. 4*10	4	4*10 W,SW	
43		145861-30830	LID, MUFFLER	1		C
46		145510-30830	GASKET, MUFFLER	1		A
47		900162-06020	BOLT, H.S. 6*20	2	6*20 W.SW	
48		145711-30830	BRACKET, MUFFLER	1		C
49		145813-31730	COVER, MUFFLER	1		C
50		900162-05020	BOLT, H.S. 5*20	1	5*20 W,SW	

Class : Consumable class

A:Fast moving parts B:Semi-fast moving parts C:Slow moving parts D:Order only as needed

STARTER, MAGNETO

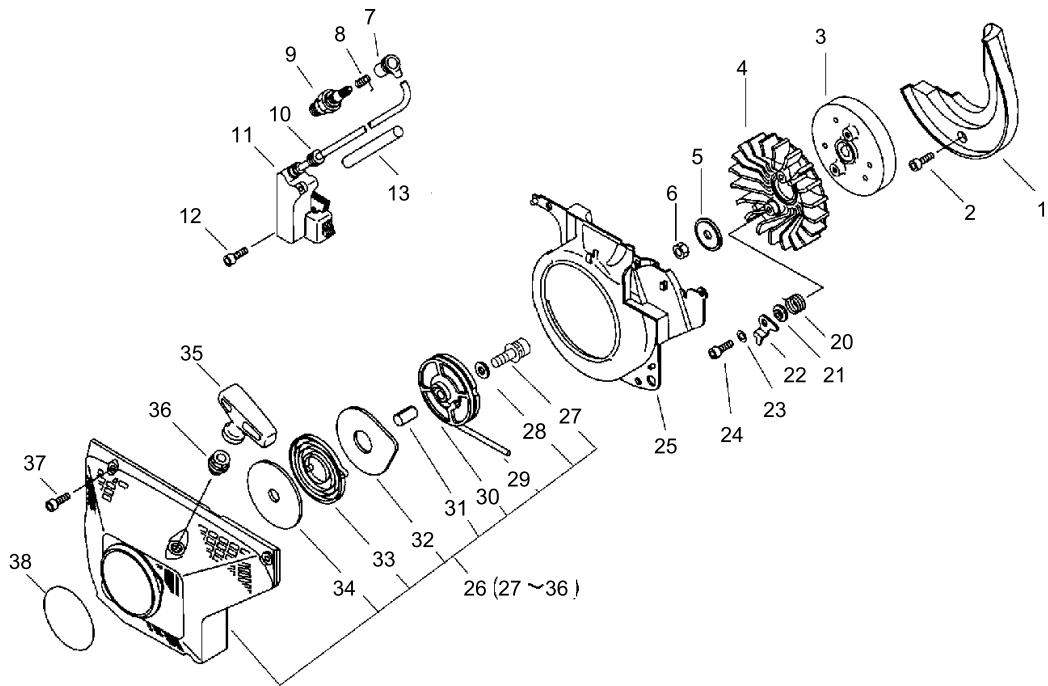

STARTER, MAGNETO

Key No.	LV (+)	Parts Number	Parts Description	Qty	Standard	Class
1		101534-30830	PLATE, GUIDE	1		C
2		900162-05020	BOLT, H.S. 5*20	2	5*20 W,SW	
3		156800-32631	ROTOR, MAGNETO	1		C
4		101521-30832	FAN, COOLING	1		C
5		100143-19830	WASHER	1	8.2*31*0.8	C
6		433019-12330	NUT, FLANGE 8	1	M-8	C
7		159012-03433	CAP, SPARK PLUG	1		C
8		159011-03432	COIL, SPARK PLUG	1		C
9		159017-31730	PLUG, SPARK RCJ-6Y	1	RCJ-6Y	A
10		152112-05730	BUSHING	1		C
11		156601-30832	COIL, IGNITION	1		C
12		900162-04020	BOLT, H.S. 4*20	2	4*20 W,SW	
13		150611-30830	TUBE	1	7*8.6*45	C
20		177234-30830	SPRING, RETURN	2		B
21		177247-12331	SPACER, RATCHET	2		C
22		177218-30830	PAWL, STARTER	2		C
23		900603-00005	WASHER 5	2	5.5*12*0.8	
24		V203-000140	BOLT,5	2	5*30	C
25		101535-30830	COVER, FAN	1		C
26		177200-30831	STARTER ASSY	1		
27	+	900162-05014	BOLT, H.S. 5*14	1	5*14 W,SW	
28	+	177214-02830	WASHER	1	5.2*16*1.0T	C
29	+	177226-07060	ROPE, STARTER	1	4.0*950	B
30	+	177206-12330	DRUM, STARTER	1		C
31	+	177216-12330	COLLAR	1		C
32	+	177242-30830	PLATE, STARTER	1		C
33	+	177220-02834	SPRING, REWIND	1		B
34	+	177221-02830	PLATE, STARTER	1		C
35	+	177228-30830	GRIP, STARTER	1		C
36	+	177227-10630	GUIDE, ROPE	1		C
37		900162-05020	BOLT, H.S. 5*20	4	5*20 W,SW	
38		X502-000460	LABEL,ECHO	1		D

Class : Consumable class

A:Fast moving parts B:Semi-fast moving parts C:Slow moving parts D:Order only as needed

HANDLE

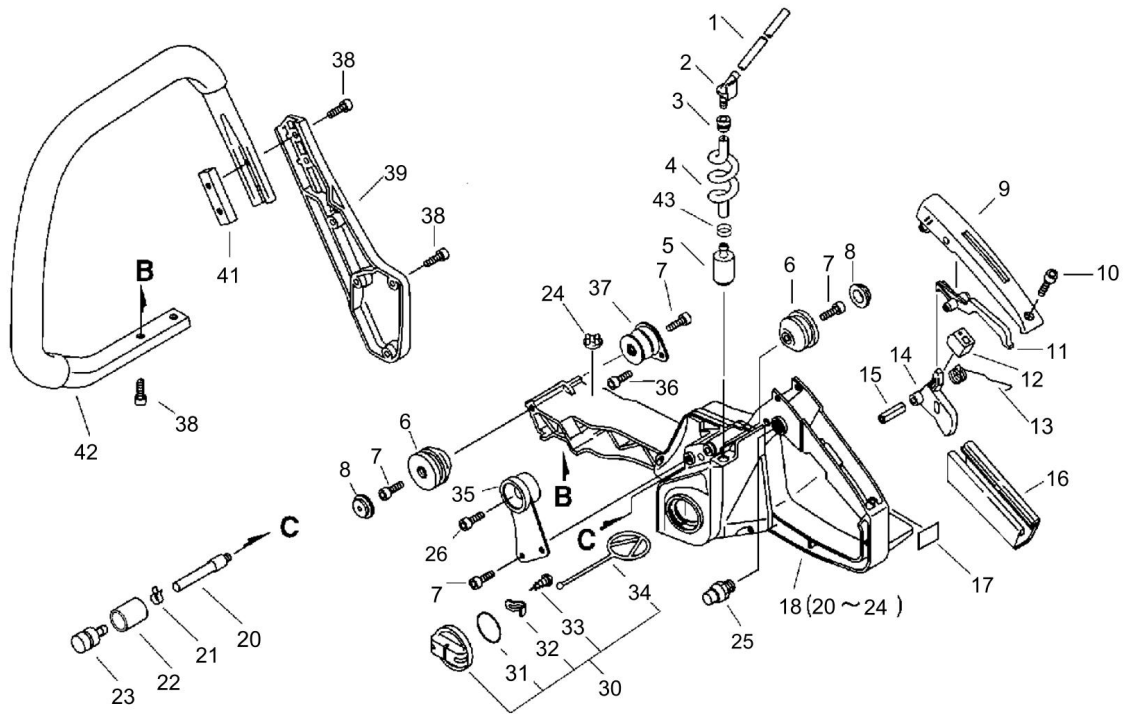

HANDLE

Key No.	LV (+)	Parts Number	Parts Description	Qty	Standard	Class
1		132012-02960	PIPE, FUEL	1	3*6*120L	C
2		132011-19831	CONNECTOR, FUEL PIPE	1		C
3		132115-01461	GROMMET	1		C
4		132010-30830	PIPE	1		C
5		131205-19831	STRAINER, FUEL	1		A
6		100910-30830	CUSHION	2		B
7		900162-05014	BOLT, H.S. 5*14	5	5*14 W,SW	
8		100918-19830	CAP, CUSHION	2		C
9		351155-30131	COVER, HANDLE	1		C
10		900162-04014	BOLT, H.S. 4*14	1	4*14 W,SW	
11		178090-30130	LOCKOUT, T. CONTROL	1		C
12		178073-32430	CUSHION, THROTTLE	1		B
13		178043-19830	SPRING, THR. RETURN	1		B
14		178010-19830	CONTROL, THROTTLE	1		C
15		900342-50025	PIN, SPRING 5*25	1	5*25	
16		351111-19830	GRIP, HANDLE	1		C
17		890157-39130	LABEL, SWITCH	1		D
18		351103-30832	HANDLE,W/FUEL TANK	1		
20	+	437210-31730	PIPE 3*5*55	1		C
21	+	130111-00530	CLIP	1	5.5	C
22	+	131328-40630	COVER, VENT	1		D
23	+	131300-56430	VALVE, CHECK	1		B
24	+	100252-30830	CUSHION	1		B
25		178302-12330	LATCH, THROTTLE	1		
26		900162-05020	BOLT, H.S. 5*20	1	5*20 W,SW	
30		131004-19831	CAP ASSY, FUEL TANK	1		
31	+	900720-20029	O-RING 29	1	P-29	
32	+	131050-19830	RETAINER, LINK	1		C
33	+	900246-03008	SCREW 3*8	1	3*8	
34	+	131051-19830	LINK	1	60L	B
35		100917-30830	CUSHION	1		B
36		900162-04010	BOLT, H.S. 4*10	2	4*10 W,SW	
37		100922-30830	CUSHION	1		B
38		900162-05020	BOLT, H.S. 5*20	8	5*20 W,SW	
39		351614-60830	BRACKET, F. HNDL. BS	1		C
41		305114-06060	BRACKET	1		C
42		351606-60830	HANDLE, FRONT	1		C
43		132013-26630	CLIP	1	6.5MM	C

Class : Consumable class

A:Fast moving parts B:Semi-fast moving parts C:Slow moving parts D:Order only as needed

CLUTCH, SPROCKET

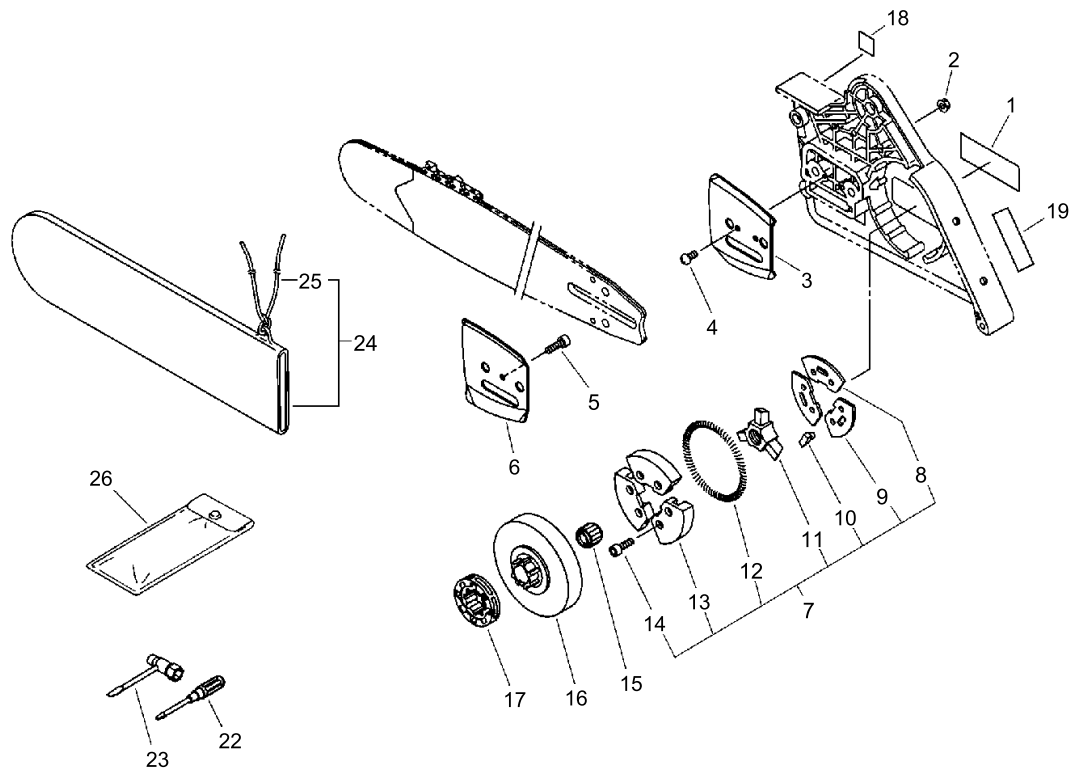

CLUTCH, SPROCKET

Key No.	LV (+)	Parts Number	Parts Description	Qty	Standard	Class
1		X502-000560	LABEL,ECHO	1		D
2		433019-12330	NUT, FLANGE 8	2	M-8	C
3		433012-30830	PLATE, GUIDE (OUTER)	1		C
4		900241-03006	SCREW 3*6	2	3*6	
5		900241-04008	SCREW 4*8	1	4*8	
6		433013-30830	PLATE, GUIDE (INNER)	1		C
7		175000-30832	CLUTCH ASSEMBLY	1		B
8	+	175019-30830	PLATE, CLUTCH	2		C
9	+	175029-30830	PLATE, CLUTCH	1		C
10	+	175059-30830	PLATE, SPRING	1		B
11	+	175016-30830	HUB, CLUTCH	1		B
12	+	175018-30830	SPRING, CLUTCH	1		B
13	+	175002-30831	SHOE, CLUTCH	1		
14	+	900105-04008	BOLT, H.S. 4*8	6	4*8	
15		175012-30831	BEARING, NEEDLE	1		C
16		175105-30831	DRUM, CLUTCH	1		B
17		175033-14731	SPROCKET, RIM 68210S	1		B
18		890316-39130	LABEL, CAUTION	1		D
19		890155-30130	LABEL, CAUTION	1		D
22		895812-03930	DRIVER, SCREW 50	1		D
23		X602-000080	TOOL,WRENCH	1	13*19 L180	D
24		P021-014640	SCABBARD,CHAIN	1		
25	+	898568-14530	ROPE	1	5*900	B
26		898510-07130	BAG, TOOL	1		

Class : Consumable class

A:Fast moving parts B:Semi-fast moving parts C:Slow moving parts D:Order only as needed

AUTO-OILER

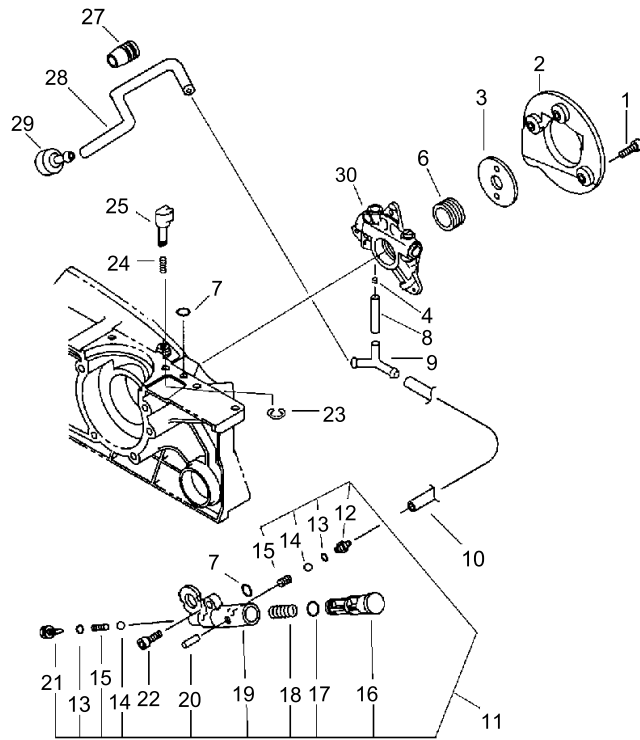

AUTO-OILER

Key No.	LV (+)	Parts Number	Parts Description	Qty	Standard	Class
1		900162-04014	BOLT, H.S. 4*14	3	4*14 W,SW	
2		437605-32430	COVER, OIL PUMP	1		D
3		437066-30831	WASHER, CIRCULAR	1		C
4		132013-26630	CLIP	1	6.5MM	C
6		437063-33231	GEAR, WORM	1		B
7		900720-00003	O-RING P-3	2	P-3	
8		437211-32430	PIPE	1		C
9		437212-32430	CONNECTOR, OIL PIPE	1		C
10		437210-30830	PIPE, OIL	1	NBR 3*6*210L	C
11		437100-19832	OILER ASY, MANUAL	1		
12	+	437118-19830	NIPPLE	1		C
13	+	437122-03430	O-RING	2		A
14	+	437012-00330	VALVE, BALL	2		C
15	+	V450-000290	SPRING, COMPRESSION	2		B
16	+	437112-19831	PISTON, MANUAL	1		D
17	+	900720-00007	O-RING 7	1	P-7	
18	+	437111-19830	SPRING	1		B
19	+	437110-19831	BODY, OIL PUMP	1		D
20	+	900345-20016	PIN, SPRING 2*16SUS	1	2*16SUS	
21	+	437121-10130	ADAPTER, OIL PUMP	1		C
22		900162-05020	BOLT, H.S. 5*20	1	5*20 W,SW	
23		900700-00003	E-RING 3	1	CE-3	
24		437015-19830	SPRING	1		B
25		437039-30830	KNOB	1		D
27		132115-12330	GROMMET	1		C
28		437210-38330	PIPE, OIL	1		C
29		436205-14730	STRAINER, OIL	1		B
30		437002-37530	AUTO-OILER ASSY	1		C

Class : Consumable class

A:Fast moving parts B:Semi-fast moving parts C:Slow moving parts D:Order only as needed

CHAIN BRAKE ASSEMBLY

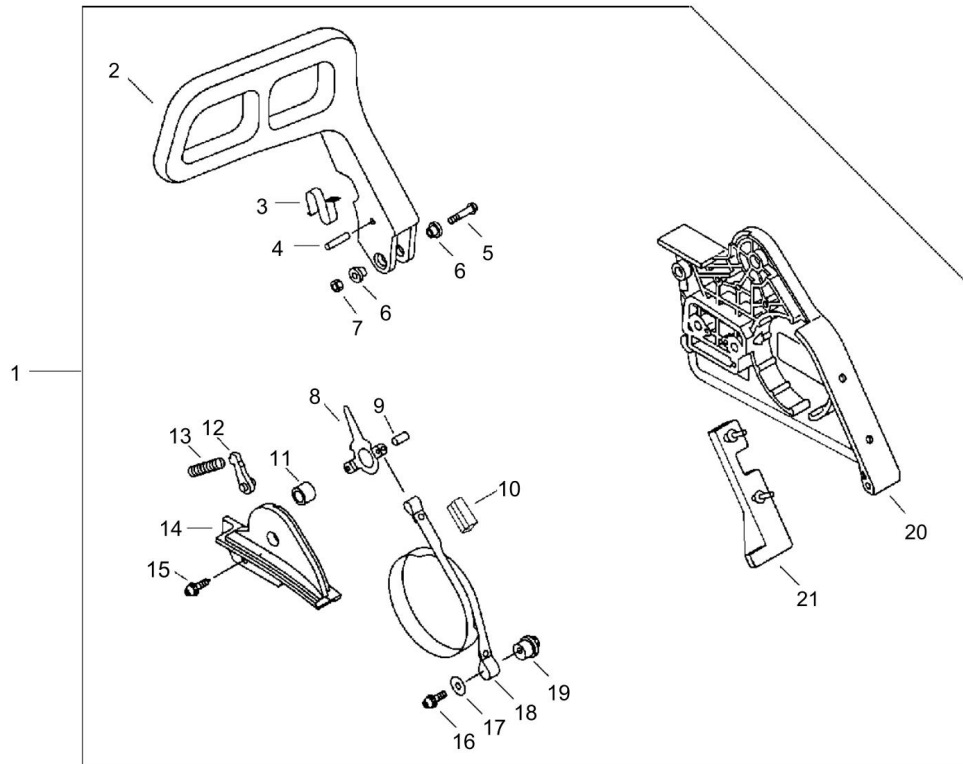

CHAIN BRAKE ASSEMBLY

Key No.	LV (+)	Parts Number	Parts Description	Qty	Standard	Class
1		P021-007312	BRAKE ASY, CHAIN	1		
2	+	433105-60830	LEVER, BRAKE	1		C
3	+	433114-38331	SPRING	1		C
4	+	900330-35260	PIN 3.5*26	1	3.5*26	
5	+	91335-05035	SCREW	1		
6	+	433167-39130	SPACER	2		C
7	+	900562-50005	NUT, LOCK	1	5	
8	+	433208-35431	CONNECTOR, BRAKE	1		C
9	+	900330-40088	ROLLER	1	4*8.8	
10	+	433312-32630	COVER, SEAL	1		D
11	+	433115-38330	WASHER 5.2*12*14	1	5.2*12*14	C
12	+	433209-35430	STOPPER, BRAKE	1		D
13	+	433122-38130	SPRING, BRAKE	1		B
14	+	433310-60830	COVER, BRAKE	1		C
15	+	900238-04010	SCREW	2	4*10	
16	+	900238-05025	SCREW	1	5*25	
17	+	351249-06960	WASHER	1		C
18	+	433123-60830	BAND, BRAKE	1		C
19	+	433142-60830	ADJUSTER, BRAKE	1		D
20	+	433010-60830	GUARD, SPROCKET	1		C
21	+	433025-60830	PAD, GUARD	1		B

Class : Consumable class

A:Fast moving parts B:Semi-fast moving parts C:Slow moving parts D:Order only as needed

CARBURETOR

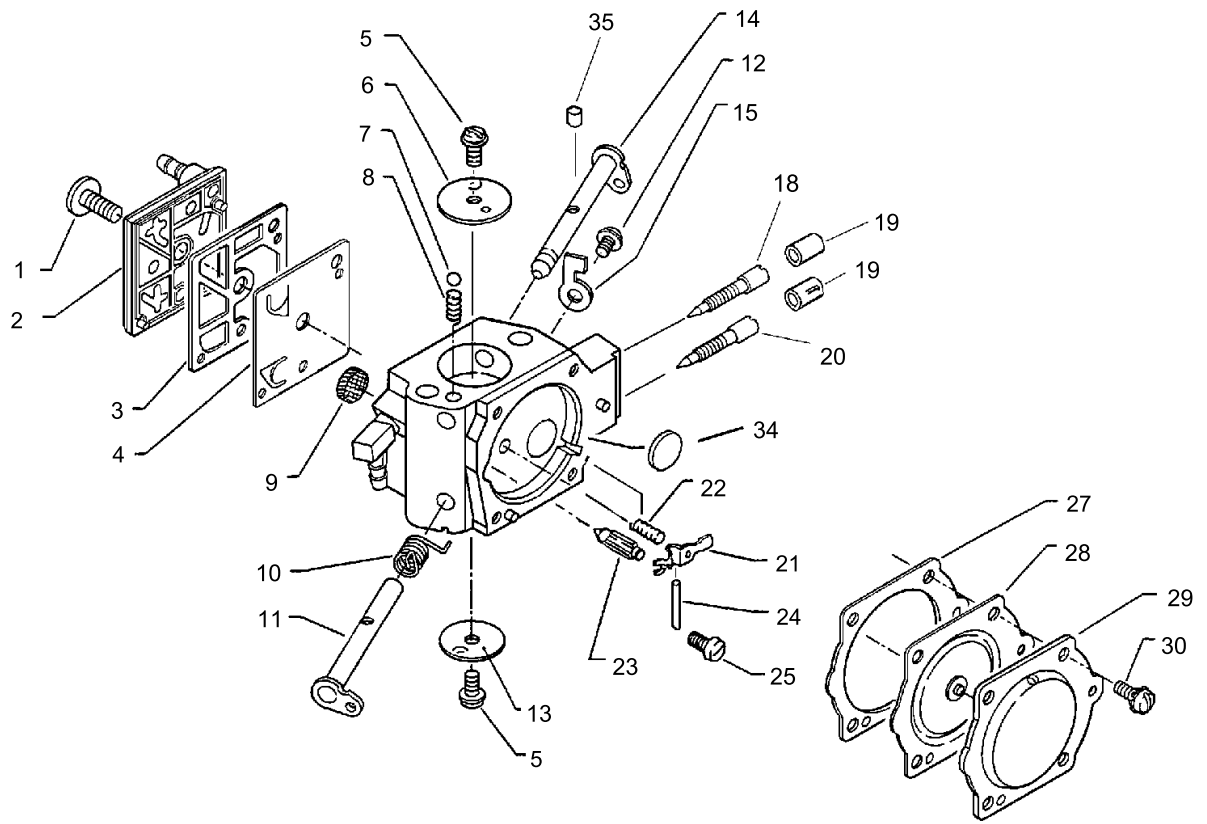

CARBURETOR

Key No.	LV (+)	Parts Number	Parts Description	Qty	Standard	Class
		123000-38832	CARBURETOR HDA-153B	1	HDA-153B	B
1	+	123110-16130	SCREW, PUMP COVER	1		D
2	+	123124-19830	COVER, FUEL PUMP	1		D
3	+	123125-12330	GASKET, FUEL PUMP	1		A
4	+	123112-12330	DIAPHRAGM, FUEL PUMP	1		A
5	+	123114-38830	SCREW	2		D
6	+	123132-17330	VALVE, CHOKE	1		
7	+	123136-10630	BALL, CHOKE FRICTION	1		D
8	+	123135-10630	SPRING, CHOKE FRICT.	1		D
9	+	123126-10631	SCREEN, INLET	1		B
10	+	123113-16130	SPRING, THRT. RETURN	1		
11	+	123117-32430	SHAFT, THROTTLE	1		
12	+	123114-38830	SCREW	1		D
13	+	123116-16130	VALVE, THROTTLE	1		D
14	+	123131-19830	SHAFT, CHOKE	1		
15	+	123156-30830	STOP, THROTTLE	1		D
18	+	123120-32631	NEEDLE, HIGH SPEED	1		D
19	+	P003-000010	LIMITER CAP	2		B
20	+	123118-02261	NEEDLE	1		D
21	+	123123-18330	LEVER, METERING	1		D
22	+	123122-32630	SPRING, METER. LEVER	1		D
23	+	123137-19830	VALVE, INLET NEEDLE	1		D
24	+	123138-03930	PIN, METERING LEVER	1		D
25	+	123139-03930	SCREW, M. LEVER PIN	1		D
27	+	123140-16131	GASKET, M. DIAPHRAGM	1		
28	+	123141-16131	DIAPHRAGM, METERING	1		
29	+	123142-17330	COVER, M. DIAPHRAGM	1		D
30	+	123130-02960	SCREW	4		D
34	+	123146-10631	PLUG, WELCH	1		C
35	+	123178-15030	PLUG, FRICTION	1		

Class : Consumable class

A:Fast moving parts B:Semi-fast moving parts C:Slow moving parts D:Order only as needed

NUMERICAL PARTS INDEX

Part No	Part description	Page	Part No	Part description	Page	Part No	Part description	Page
100011-30831	RING, PISTON	2	123132-17330	VALVE, CHOKE	18	145510-30830	GASKET, MUFFLER	6
100012-30830	BEARING, NEEDLE	2	123135-10630	SPRING, CHOKE FRICT.	18	145610-30830	MUFFLER	6
100015-30830	CIRCLIP, PISTON PIN	2	123136-10630	BALL, CHOKE FRICTION	18	145711-30830	BRACKET, MUFFLER	6
100100-30830	CRANKSHAFT ASSY	2	123137-19830	VALVE, INLET NEEDLE	18	145813-31730	COVER, MUFFLER	6
100142-30830	KEY, WOODRUFF	2	123138-03930	PIN, METERING LEVER	18	145861-30830	LID, MUFFLER	6
100143-19830	WASHER	8	123139-03930	SCREW, M. LEVER PIN	18	150611-30830	TUBE	8
100204-30832	CRANKCASE KIT	2	123140-16131	GASKET, M. DIAPHRAGM	18	152112-05730	BUSHING	8
100212-19830	OILSEAL	2	123141-16131	DIAPHRAGM, METERING	18	156114-04920	GROMMET	6
100213-30830	OILSEAL	2	123142-17330	COVER, M. DIAPHRAGM	18	156601-30832	COIL, IGNITION	8
100215-02830	PIN, DOWEL	2	123146-10631	PLUG, WELCH	18	156800-32631	ROTOR, MAGNETO	8
100242-30830	GASKET, CRANKCASE	2	123156-30830	STOP, THROTTLE	18	159011-03432	COIL, SPARK PLUG	8
100252-30830	CUSHION	10	123178-15030	PLUG, FRICTION	18	159012-03433	CAP, SPARK PLUG	8
100905-19830	CUSHION	6	129010-38830	GROMMET, NEEDLE	6	159017-31730	PLUG, SPARK RCJ-6Y	8
100910-30830	CUSHION	10	129011-19831	PLATE	6	162021-30830	LEAD	6
100917-30830	CUSHION	10	129013-30831	SCREW, IDLE SPEED	6	163400-30830	SWITCH, IGNITION	6
100918-19830	CAP, CUSHION	10	130007-30830	INSULATOR	6	175000-30832	CLUTCH ASSEMBLY	12
100921-30830	CUSHION	2	130012-30830	SEAL, DUST	6	175002-30831	SHOE, CLUTCH	12
100922-30830	CUSHION	10	130020-19830	NUT	6	175012-30831	BEARING, NEEDLE	12
101010-30830	GASKET, CYL. BASE	2	130110-30830	PIPE, IMPULSE	6	175016-30830	HUB, CLUTCH	12
101501-31730	COVER, CYLINDER	2	130111-00530	CLIP	10	175018-30830	SPRING, CLUTCH	12
101520-33330	COVER	2	130302-30830	COVER SET, AIR CLN	6	175019-30830	PLATE, CLUTCH	12
101521-30832	FAN, COOLING	8	130303-30831	FILTER, AIR W/SEAL	6	175029-30830	PLATE, CLUTCH	12
101529-30830	PLATE, GUIDE (A)	6	130306-30830	CASE, CARBURETOR(BS)	6	175033-14731	SPROCKET, RIM 68210S	12
101534-30830	PLATE, GUIDE	8	130320-30831	SEAL, CLEANER	6	175059-30830	PLATE, SPRING	12
101535-30830	COVER, FAN	8	130339-30830	PLUG	6	175105-30831	DRUM, CLUTCH	12
101541-30831	PLATE, GUIDE	2	130356-19830	GROMMET	6	177200-30831	STARTER ASSY	8
101578-30830	PLUG	2	130405-30830	SUPPORTER, FILTER	6	177206-12330	DRUM, STARTER	8
123000-38832	CARBURETOR HDA-153B	6	130406-30830	NUT, THUMB	6	177214-02830	WASHER	8
123000-38832	CARBURETOR HDA-153B	18	130510-30830	ADAPTER, INTAKE	2	177216-12330	COLLAR	8
123110-16130	SCREW, PUMP COVER	18	130516-30830	BAND	2	177218-30830	PAWL, STARTER	8
123112-12330	DIAPHRAGM, FUEL PUMP	18	131004-19831	CAP ASSY, FUEL TANK	10	177220-02834	SPRING, REWIND	8
123113-16130	SPRING, THRT. RETURN	18	131050-19830	RETAINER, LINK	2	177221-02830	PLATE, STARTER	8
123114-38830	SCREW	18	131050-19830	RETAINER, LINK	10	177226-07060	ROPE, STARTER	8
123116-16130	VALVE, THROTTLE	18	131051-19830	LINK	2	177227-10630	GUIDE, ROPE	8
123117-32430	SHAFT, THROTTLE	18	131051-19830	LINK	10	177228-30830	GRIP, STARTER	8
123118-02261	NEEDLE	18	131205-19831	STRAINER, FUEL	10	177234-30830	SPRING, RETURN	8
123120-32631	NEEDLE, HIGH SPEED	18	131300-56430	VALVE, CHECK	10	177242-30830	PLATE, STARTER	8
123122-32630	SPRING, METER. LEVER	18	131328-40630	COVER, VENT	10	177247-12331	SPACER, RATCHET	8
123123-18330	LEVER, METERING	18	132010-30830	PIPE	10	178010-19830	CONTROL, THROTTLE	10
123124-19830	COVER, FUEL PUMP	18	132011-19831	CONNECTOR, FUEL PIPE	10	178043-19830	SPRING, THR. RETURN	10
123125-12330	GASKET, FUEL PUMP	18	132012-02960	PIPE, FUEL	10	178073-32430	CUSHION, THROTTLE	10
123126-10631	SCREEN, INLET	18	132013-26630	CLIP	10	178078-19830	SPRING	6
123130-02960	SCREW	18	132013-26630	CLIP	14	178090-30130	LOCKOUT, T. CONTROL	10
123131-19830	SHAFT, CHOKE	18	132115-01461	GROMMET	10	178114-19830	HOLDER, THR. LEVER	6
			132115-12330	GROMMET	14	178302-12330	LATCH, THROTTLE	10

NUMERICAL PARTS INDEX

Part No	Part description	Page	Part No	Part description	Page	Part No	Part description	Page
178307-30830	ROD, THROTTLE	6	437121-10130	ADAPTER, OIL PUMP	14	900241-04008	SCREW 4*8	12
178510-30830	ROD, CHOKE	6	437122-03430	O-RING	14	900242-04008	SCREW	6
178810-11231	GROMMET	6	437210-30830	PIPE, OIL	14	900246-03008	SCREW 3*8	2
305114-06060	BRACKET	10	437210-31730	PIPE 3* 5* 55	10	900246-03008	SCREW 3*8	10
351103-30832	HANDLE,W/FUEL TANK	10	437210-38330	PIPE, OIL	14	900330-35260	PIN 3.5*26	16
351111-19830	GRIP, HANDLE	10	437211-32430	PIPE	14	900330-40088	ROLLER	16
351155-30131	COVER, HANDLE	10	437212-32430	CONNECTOR, OIL PIPE	14	900342-50025	PIN, SPRING 5*25	10
351249-06960	WASHER	16	437605-32430	COVER, OIL PUMP	14	900345-20016	PIN, SPRING 2*16SUS	14
351606-60830	HANDLE, FRONT	10	880210-30830	BUMPER, SPIKED	2	900345-50010	PIN, SPRING 5*10SUS	2
351614-60830	BRACKET, F. HNDL. BS	10	890155-30130	LABEL, CAUTION	12	900562-50005	NUT, LOCK	16
433010-60830	GUARD, SPROCKET	16	890157-19830	LABEL, SWITCH	6	900600-00005	WASHER 5	2
433011-19830	STUD, GUIDE BAR	2	890157-39130	LABEL, SWITCH	10	900603-00005	WASHER 5	8
433012-30830	PLATE, GUIDE (OUTER)	12	890169-60830	LABEL, ADJUSTING	6	900605-00006	SPRING WASHER	2
433013-30830	PLATE, GUIDE (INNER)	12	890316-39130	LABEL, CAUTION	12	900700-00003	E-RING 3	14
433014-02830	TENSIONER	2	890345-39230	LABEL,CAUTION	4	900720-00003	O-RING P-3	6
433016-11031	SCREW, TENSIONER	2	890631-38130	LABEL, CAUTION	4	900720-00003	O-RING P-3	14
433019-12330	NUT, FLANGE 8	8	895812-03930	DRIVER, SCREW 50	12	900720-00007	O-RING 7	14
433019-12330	NUT, FLANGE 8	12	898510-07130	BAG, TOOL	12	900720-00010	O-RING P-10	6
433025-60830	PAD, GUARD	16	898568-14530	ROPE	12	900720-20029	O-RING 29	10
433028-11030	CLIP	2	900105-04008	BOLT, H.S. 4*8	12	900721-00025	O-RING 25	2
433105-60830	LEVER, BRAKE	16	900105-06020	BOLT, H.S. 6*20	2	900810-36203	BEARING, BALL 6203	2
433114-38331	SPRING	16	900162-04010	BOLT, H.S. 4*10	6	91335-05035	SCREW	16
433115-38330	WASHER 5.2*12*14	16	900162-04010	BOLT, H.S. 4*10	10	P003-000010	LIMITER CAP	18
433122-38130	SPRING, BRAKE	16	900162-04014	BOLT, H.S. 4*14	10	P021-005410	CYLINDER ASY	2
433123-60830	BAND, BRAKE	16	900162-04014	BOLT, H.S. 4*14	14	P021-005420	PISTON KIT	2
433142-60830	ADJUSTER, BRAKE	16	900162-04020	BOLT, H.S. 4*20	8	P021-007312	BRAKE ASY, CHAIN	16
433167-39130	SPACER	16	900162-05014	BOLT, H.S. 5*14	2	P021-014070	CHAIN CATCHER KIT	2
433208-35431	CONNECTOR,BRAKE	16	900162-05014	BOLT, H.S. 5*14	6	P021-014640	SCABBARD,CHAIN	12
433209-35430	STOPPER, BRAKE	16	900162-05014	BOLT, H.S. 5*14	8	V203-000140	BOLT,5	8
433310-60830	COVER, BRAKE	16	900162-05014	BOLT, H.S. 5*14	10	V450-000290	SPRING,COMPRESSION	14
433312-32630	COVER, SEAL	16	900162-05020	BOLT, H.S. 5*20	2	V611-000000	PIN,ENG 13	2
436001-31730	CAP ASSY, OIL TANK	2	900162-05020	BOLT, H.S. 5*20	6	X502-000460	LABEL,ECHO	8
436114-13930	VALVE, CHECK	2	900162-05020	BOLT, H.S. 5*20	8	X502-000560	LABEL,ECHO	12
436205-14730	STRAINER, OIL	14	900162-05020	BOLT, H.S. 5*20	10	X503-009160	LABEL,MODEL	6
437002-37530	AUTO-OILER ASSY	14	900162-05020	BOLT, H.S. 5*20	14	X602-000080	TOOL,WRENCH	12
437012-00330	VALVE, BALL	14	900162-05025	BOLT, H.S. 5*25	6			
437015-19830	SPRING	14	900162-05035	BOLT, H.S. 5*35	2			
437039-30830	KNOB	14	900162-05055	BOLT, H.S. 5*55	6			
437063-33231	GEAR, WORM	14	900162-06020	BOLT, H.S. 6*20	6			
437066-30831	WASHER, CIRCULAR	14	900162-06025	BOLT, H.S. 6*25	2			
437100-19832	OILER ASY, MANUAL	14	900220-04008	SCREW 4*8	6			
437110-19831	BODY, OIL PUMP	14	900238-04010	SCREW	16			
437111-19830	SPRING	14	900238-05014	SCREW 5*14	2			
437112-19831	PISTON, MANUAL	14	900238-05025	SCREW	16			
437118-19830	NIPPLE	14	900241-03006	SCREW 3*6	12			